



# ARMSTRONG CONTRACT INTERIORS

SHOWROOMS  
NEW YORK  
CHICAGO  
LOS ANGELES



Circle 2 on inquiry card





ARCHITECTURAL RECORD (Combined with AMERICAN ARCHITECT, and WESTERN ARCHITECT AND ENGINEER) (ISSN0003-858X/91) May 1991, Vol. 179, No. 5. Title © reg. in U. S. Patent Office, copyright ©1991 by McGraw-Hill, Inc. All rights reserved. Indexed in Reader's Guide to Periodical Literature, Art Index, Applied Science and Technology Index, Engineering Index, The Architectural Index, the Architectural Periodicals Index, and the Construction Index.

Every possible effort will be made to return material submitted for possible publication (if accompanied by stamped, addressed envelope), but the editors and the corporation will not be responsible for loss or damage.

*Executive, Editorial, Circulation and Advertising Offices:* 1221 Avenue of the Americas, New York, NY 10020.

*Officers of McGraw-Hill, Inc.:* Chairman, President and Chief Executive Officer: Joseph L. Dionne. Executive Vice President, General Counsel and Secretary: Robert N. Landes. Executive Vice President: Walter D. Serwatka. Senior Vice President, Treasury Operations: Frank D. Penglase. Senior Vice President, Editorial: Ralph R. Schulz.

*Associated Services:* Sweet's Catalog Files (General Building, Engineering, Industrial Construction and Renovation, Light Residential Construction, Interiors), Dodge Reports and Bulletins, Dodge/SCAN Microfilm Systems, Dodge Construction Statistics, Dodge regional construction newspapers (Chicago, Denver, Los Angeles, San Francisco).

Subscription rates are as follows: U. S. Possessions and Canada \$42.50; Europe: \$150.00; Japan: \$160.00 (including Air); all other Foreign: \$125.00. Single copy price for \$7.00; For Foreign: \$100.00. For Subscriber Services: 609/426-7070.

*Change of Address:* Forward changes of address or service letters to Fulfillment Manager, ARCHITECTURAL RECORD, P. O. 566, Hightstown, NJ 08520. Provide both old and new address; include zip code; if possible attach issue address label.

*Guarantee:* Publisher agrees to refund that part of subscription price applying to unfilled part of subscription if service is unsatisfactory. Publisher reserves right to accept or reject any subscription.

*Copyright and Reprinting:* Title © reg. in U. S. Patent Office. Copyright ©1991 by McGraw-Hill, Inc. All rights reserved. Where necessary, permission is granted by the copyright owner for libraries and others registered with the Copyright Clearance Center (CCC) to photocopy any article herein for personal or internal reference use only for the base fee of \$1.50 per copy of the article plus ten cents per page. Payment should be sent directly to the CCC, 27 Congress Street, Salem, MA 01970. Include code with request: ISSN0003-858X/91 (\$1.50 + .10). Written permission must be secured for any other copying. Write Reprint Manager for such permission at address below, or to obtain quotations on bulk orders.

*Subscription List Usage:* Advertisers may use our list to mail information to readers. To be excluded from such mailings, send a request to ARCHITECTURAL RECORD, Mailing List Mgr., P. O. Box 566, Hightstown, NJ 08520.

ARCHITECTURAL RECORD (ISSN0003-858X/91) published monthly by McGraw-Hill, Inc. Second-class postage paid at New York, NY and additional mailing offices. Postage paid at Montreal, Quebec, Canada. Registration Number 9617. Registered for GST as McGraw-Hill, Inc. GST Number R128075873

*Postmaster:* Please send address changes to: ARCHITECTURAL RECORD, Attn: Fulfillment Manager, P. O. Box 566, Hightstown, NJ 08520. THIS ISSUE is published in national and separate editions. Additional pages or separate editions numbered or allowed for as follows: Eastern Section 131E and 132E Western Section 131W and 132W.

### November Editorial

Re: November 1990 Editorial [RECORD, page 11], "What Is Good Design?"  
One good editorial!  
*Cabel Childress, Architect  
Denver*

### Moss toss-up

Referring to Eric Owen Moss's Gary Group Building [RECORD, March 1991, pages 106-113], I see more of Stephen King in it than James Joyce. And no amount of verbal calisthenics from Aaron Betsky can save this one. In plain English it is simply BAD ARCHITECTURE.  
*Lourdes Tuazon  
South Pasadena, California*

How reassuring it was to see Eric Owen Moss's Gary Group Building in your March issue. I was just in California and had a chance to see the building itself, which confirmed the impression I had originally got from RECORD . . . that it's quite brilliant. Having worked on an architecture magazine myself for over 16 years, I know that it takes some courage to publish such work.

*David A. Morton,  
Rizzoli International  
Publications, Inc.  
New York City*

### RECORD Redesign

Re the new format/March issue: WOW!  
*Michael John Smith, Architect  
Houston*

We just received the March issue. We love it. A really great look for a magazine—a great presentation of architecture and product news. We are particularly impressed with how you decided to handle the advertising and editorial. We need and use advertisements in our design business as resource,

and we have always looked to the professional design and architectural journals to supply the information. For the first time, someone has made sense of the advertising/editorial relationship. It makes reading your magazine a real pleasure.

*Michael Donovan  
Donovan and Green  
New York City*

Congratulations on RECORD's handsome new look. Gone are the fearful symmetry and the overwhelmingly bold graphics. The cover photograph now gets the emphasis that it deserves. The layout of the major articles is also handsome and readable. The "yellow pages" is an interesting idea, but it is the graphic equivalent of a leaky roof. I urge you to give up the red ink as a good idea that did not work.  
*Henrik Bull, Architect  
Bull, Stockwell & Allen  
San Francisco*

*The overly orange tone of the new yellow pages indeed needed changing. Look to this issue for a more readable section.—Ed.*

### Corrections

In "Focus On Preservation," [RECORD, March 1991, pages 152-155], Greg Lofin's photo at bottom right on page 153, which is of Cambridge Seven's Greensboro Cultural Center, was mistakenly transposed with Alan Karchmer's top photo on page 155, of Concordia Architects' New Orleans Contemporary Arts Center.

Building E of the Main Complex of the World Bank [RECORD, March 1991, page 164] was not designed by Vincent Kling, but by Clas Riggs Owens & Ramos, with the firm of Vincent Kling as associate architect.

### May 19-22

International Contemporary Furniture Fair, sponsored by *Metropolis* magazine; Jacob K. Javits Convention Center, New York City. 212/686-6070.

### May 21-June 30

"The Architects' Collection," Peter Joseph Gallery, 745 Fifth Ave., New York City. 212/751-5500.

### June 3-5

"MacBuild '91," Macintosh training for architects, engineers, designers, at the Los Angeles Airport Hilton; produced by Practice Management Associates. 617/965-0055.

### June 7

"Washington: Symbol and City," new permanent exhibition at the National Building Museum, Judiciary Square, N. W., Washington, D. C. 202/272-2448.

### Through June 8

"Arata Isozaki: Prints & Drawings," Max Protetch Gallery, 560 Broadway, New York City. 212/966-5454.

### June 11-14

NEOCON 23, The Merchandise Mart, Chicago. 312/527-4141.

### Through June 23

"Edge of a City: An installation by Steven Holl," Walker Art Center, Minneapolis. 612/375-7600.

### June 28-29

"Buildings at Risk: Seismic Design Basics for Practicing Architects"; Vista Hotel, Washington, D. C. Sponsored by the AIA/ACSA Council on Architectural Research. 202/785-2324.

### June 28-30

Construction Specifications Institute 35th Annual Convention San Diego. 703/684-0300.

### September 30-October 4

"BA/91," Buenos Aires's four International Architectural Biennial. Write CAYC/BA/91, Elpidio Gonzalez 4070 (1407) Buenos Aires, Argentina; phone 011-541/568-2969.



Editor  
 Stephen A. Kliment, FAIA

Managing Editor  
 Carolyn De Witt Koenig

Executive Editor  
 Paul M. Sachner

Senior Editors  
 Margaret F. Gaskie  
 Charles K. Hoyt, AIA  
 Karen D. Stein  
 James S. Russell, AIA

Associate Editors  
 Joan F. Blatterman  
 Clifford A. Pearson  
 Peter D. Slatin

Editors at Large  
 Donald J. Canty, Hon. AIA  
 Grace M. Anderson  
 Charles D. Linn, AIA

Editorial Office Manager  
 Anne S. Ting

Design Director  
 Alberto Bucchianeri

Senior Associate Design Director  
 Anna Egger-Schlesinger

Editorial Production Manager  
 Annette K. Netburn

Designer/Production Assistant  
 William R. Engel

Technical Illustrator  
 Curriel Cuttrel

Design Consultant  
 Massimo Vignelli

Contributing Editors  
 David Ballast, AIA; Robert Campbell, AIA;  
 Christine Fallon, AIA; Peter Piven, FAIA;  
 Norma Sklarek, FAIA

Editorial Consultants  
 George A. Christie, Jr., Economics  
 Steven S. Ross, Computers  
 Phillip Kidd, Finance  
 Peter Hoffmann, Washington

Correspondents  
 Aaron Betsky, Los Angeles;  
 Keith Dunlop, Miami;  
 Nancy Levinson, New England;  
 Tracy Metz, Amsterdam;  
 Gerald Moorhead, FAIA, Houston;  
 Anders Neretim, Chicago;  
 Tomi R. Pollock, Tokyo

Director of Business and Production  
 Joseph R. Wunk

Advertising Production Manager  
 Laura Marchisio

Manager of Finance  
 Nancy A. Yetka

Publisher  
 Scoe C. Smith III

inquiries and submissions of work for publication may be sent to the editors listed below who are responsible for the subject areas named:

Paul M. Sachner, houses  
 Karen D. Stein, interior design  
 Peter D. Slatin, design news  
 Clifford A. Pearson, observations, books  
 Charles K. Hoyt, practice  
 James S. Russell, technology  
 Joan F. Blatterman, new products  
 Charles D. Linn, RECORD LIGHTING

**Introduction 57**

**Library Administration Building  
 Bond University  
 Queensland, Australia 58** *Arata Isozaki & Associates, Architect*

**1150 18th Street, NW  
 Washington, D. C. 66** *Hisaka & Associates, Architect*

**Odessa Street Beach Pavilion  
 Seaside, Florida 74** *Roger Ferri, Architect*

**Clinical Research Building  
 University of Pennsylvania  
 Philadelphia, Pennsylvania** *Two research laboratories are the latest projects in a long collaboration between Venturi, Scott Brown and Associates and Payette Associates.*

**Thayer School of Engineering  
 Dartmouth College  
 Hanover, New Hampshire 78**

**Restoration of the Dana-Thomas House  
 Springfield, Illinois 88** *Frank Lloyd Wright, Original Architect  
 Hasbrouck Peterson Associates,  
 Restoration Architect*

**CambridgeSide Galleria  
 Cambridge, Massachusetts 96** *Arrowstreet Inc., Architect*

**Eiteljorg Museum of American Indian  
 and Western Art  
 Indianapolis, Indiana 104** *Browning Day Mullins Dierdorf,  
 Architect*

**Practice 30** *Automation in practice/Finding clients/  
 Quality management/Motivating staff/  
 Construction economy update/Specifica-  
 tions—interior renovation*

**Software Reviews 42** *Two capable and cost-effective CAD  
 packages.*

**Observations/Books 46** *New books on Eliel Saarinen, Claude-  
 Nicolas Ledoux, and Berlin.*

**Letters/Calendar 4**  
**Editorial 9**  
**Design News 19**  
**Practice News 24**  
**Products 26**  
**Outtakes 44**

**Product Literature 116**  
**Manufacturer Sources 130**  
**Classified Advertising 140**  
**Advertising Index 144**  
**Reader Service Card 147**

Cover:  
*Library Administration Building, Bond University, Queensland, Australia  
 Arata Isozaki & Associates, Architect. ©Scott Frances/ESTO photo*

**SUPPLEMENT ON LIGHTING IS INCLUDED WITH THIS ISSUE  
 (with U. S. and Canadian copies only)**



Velour Texture  
Manganese/Heavy

Velour Texture  
Mahogany Color

Velour Texture  
Manganese/Fine

Velour Texture  
Butte Brown Color

Island Teal

Dawn Grey Mat

Indian Turquoise

Palisade Blue

Sandrift

Mountain Blue

Peach Sand

Terra Cotta

Highland Heather

Misty Grey

Pumice

Prairie Peach

Frost White Satin

Adobe

Architect:  
J. N. Pease Associates

University of North Carolina Center for  
Public Television, Chapel Hill, NC

# THE -MILLENNIUM- COLLECTION

**stark**  
Stark Ceramics, Inc.

Introducing a new Millennium of spirited design. It starts with your inspiration and culminates with Stark Ceramics' Millennium Collection. A peerless structural glazed ceramic wall product for exteriors that lets you design a building that's modern and sleek or warm and inviting. Create your next masterwork with Millennium. **1 800 321 0662**

Circle 5 on inquiry card



# Jumping Through Hoops

For years now clients, some out of ignorance and others through an excess of zeal, have been squeezing architects in the marketing stage to obtain the greatest possible advance services at little or no cost.

Some clients, indeed especially larger corporate ones, have been known to commission consultants to draw up, for sizable fees, elaborate documents which are then distributed to a short list of qualifying architects. For a meager fee, which seldom pays for more than overhead, firms are then required to provide such services as site analysis, models, feasibility studies, schematic design, and more.

The visit by a few members of the board or building committee to the architect's place of business is a time-honored practice, and has the virtue of letting the client size up the firm and its staff on its home field. The practice has now mushroomed to the point where an entire board comes along, and top principals spend long, unbillable hours entertaining the visitors.

With the downturn, excessive client demands have hit the small firm worse than the large, and the institutional firm more than the commercial. That's because the drop in work among the large commercial architectural firms has prompted them to turn increasingly to the livelier institutional market, seeking projects that in normal times they would turn down, and bringing their more sumptuous marketing practices and brochures to the thriftier milieu of the institutional market. Many an institutional client is happy to take advantage of the increased competition, often involving very small projects whose fees are out of proportion to the marketing effort.

Smart firms resist these kinds of blandishments. Some, once they decide to spend their own time and money on strategic research and on preparing pre-design-phase concepts for the client, do so to set up a dialog that will serve to pin down client needs, or help cement relationships, or both. Any firm that blithely offers to go beyond should be paid. The trick, as Peter Piven of The Coxe Group points out, is to know where "concepts" stop and services start—what is legitimate marketing, and what are services.

The American Institute of Architects is hamstrung by federal anti-trust fiats. It therefore puts a special obligation on every firm to set down its business objectives, and to devise and follow its marketing plan and budget—to decide which jobs are worth going after, how far even those jobs should be pursued in relation to the projected fees, and scrupulously stick to such self-imposed constraints.

It's the only prudent way to conduct a practice, and to survive a downturn without owing your soul to the bank or turning to another line of work. *Stephen A. Kliment*







**Pennsylvania**

**Robert Venturi Wins 1991 Pritzker Prize**

Robert Venturi has been named this year's winner of the Pritzker Architecture Prize. He'll receive the award, consisting of a \$100,000 grant, a medallion, and a certificate, from Jay A. Pritzker, president of the Hyatt Foundation, at a May 16 ceremony in Mexico City. Commenting on the work of the Philadelphia-based architect (see pages 78-87 or more on his firm), the jury comprising Giovanni Agnelli, J. Carter Brown, Ada Louise Huxtable, Ricardo Legorreta, Toshio Takamura, Kevin Roche, and Lord Rothschild noted that "architecture is a profession about wood, bricks, stones, steel, and glass. It is also an art form that is based on words, ideas, and conceptual frameworks. Few architects of the 20th century have been able to combine both aspects of the profession, and none have done so more successfully than Robert Venturi." The formal citation also made special mention of Venturi's partner Denise Scott Brown, praising the architects' nearly quarter-century collaboration for "allow[ing] architects and consumers the freedom to accept inconsistencies in form and pattern, to enjoy popular taste." *K. D. S.*

*Robert Venturi in his Philadelphia office*



*Matt Wargo photo*

**Georgia**

**Gund Designs Atlanta Natural History Museum**

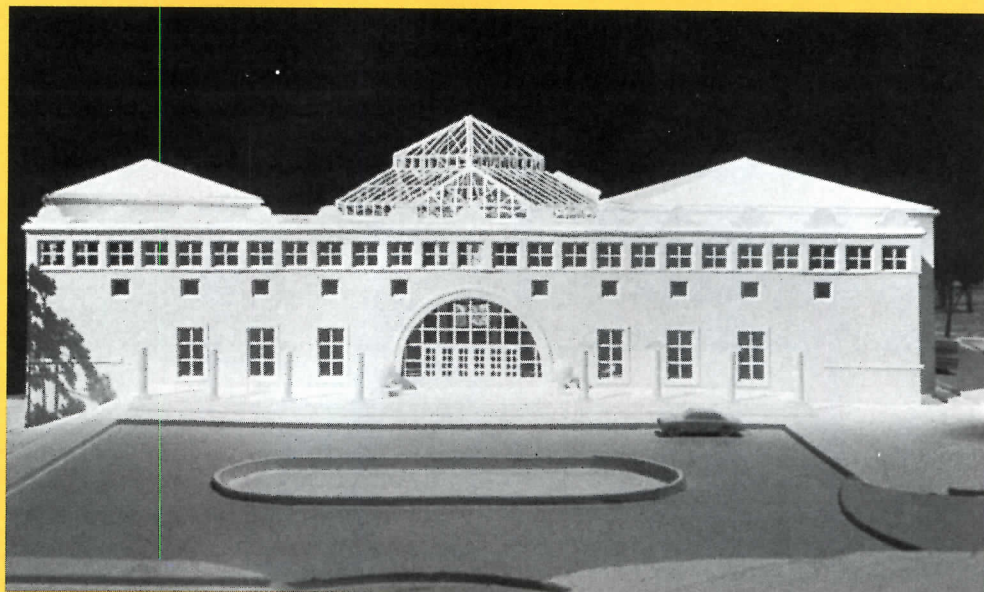

*Dave Desroches*

The grand scale of Graham Gund Architects' 150,000-sq-ft Fernbank Museum of Natural History is a nod to its monumental ancestors. Set five miles from downtown Atlanta next to the wilds of Fernbank Forest along Olmsted-designed Ponce de Leon Parkway,

the Fernbank, scheduled to open in late 1992, is the only natural history museum to be built in the U.S. this century. Light filters through the frit-glass clerestory windows to an interior courtyard that circulates visitors to galleries on three floors. ■

**Vermont**

**Pedersen Moonlights in Vermont**

Country homes aren't a building type that springs to mind at the mention of skyscraper titans Kohn Pedersen Fox. But partner William Pedersen, whose design for his own vacation house on New York's Shelter Island was widely praised, has done another residential design, this time facing Mount Stratton, in Vermont ski country. This eastern elevation of the 5,200-sq-ft wood-frame house, with a slate base and lead-coated copper batten roofs, hides the view framed by broad windows and by the pitch of the house against its own steep mountain incline. ■

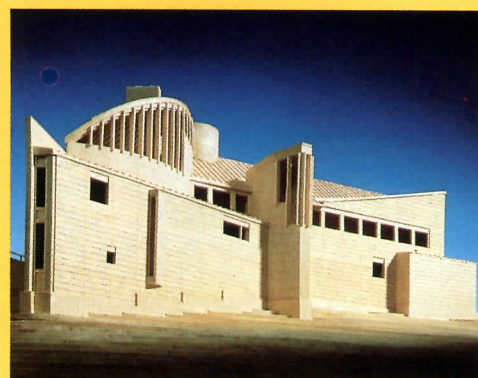

*Jock Pottle*



## California

# Fernau + Hartman Wins Napa Valley Museum Contest

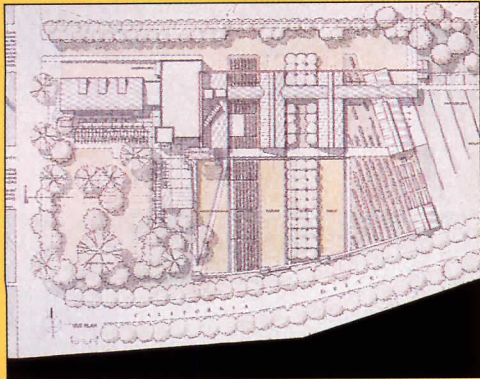

## California

# Monterey Seeks the "Real" California

"Will the Real California Architecture Please Stand Up?" pleaded the California Council of the American Institute of Architects at the 10th Biennial Monterey Design Conference last March. It didn't, but from the speakers, projects, and discussions observed in the sylvan setting of the Asilomar Conference Center, one got a pretty good idea of what such an architecture may look like.

Architects as diverse as Michael Graves and Los Angeles low-income housing designer John Mutlow pointed out that such an architecture would owe a strong debt to the non-Anglo element that is becoming an ever greater part of the California culture. Several architects from Northern California argued that it would be especially sensitive to its surroundings, in terms of climate and context. Joseph Esherick, in his keynote address, called for a new focus on an architecture that is site specific and environmentally responsive.

The real test of California architecture appears to lie in giving shape to the burgeoning exurban landscape. This subject held center stage in the discussions of large housing projects for Los Angeles and Sacramento, where teams of architects led by Andres Duany and Elizabeth Plater-Zyberk (in Los Angeles) and by Peter Calthorpe (in Sacramento) are bringing suburban and urban prototypes to bear on the tabula rasa of developable land. *Aaron Betsky*

## New York

# H. E. L. P. Housing Prototype at Work in Slum and Suburb



Jock Pottle

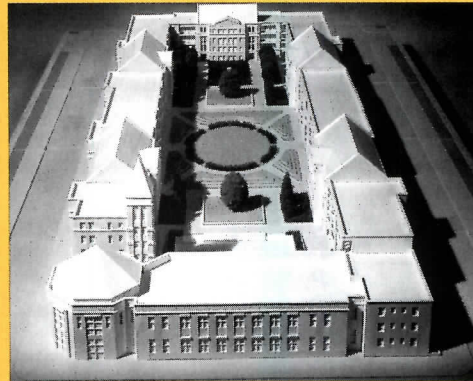

## Wisconsin

# Milwaukee Shelter . . .

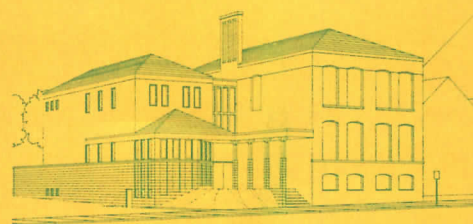

The not-for-profit Guest House of Milwaukee shelters up to 75 men and women, providing transitional housing on a small scale and for periods of no more than a week. Milwaukee's Albion Group designed a 9,000-sq-ft addition for this turn-of-the-century former church hall; the \$625,000 budget was raised locally through donations. The expansion includes offices, dayrooms, and a clinic open to the community, and sets an institutional tone to motivate residents to leave when their time is up. ■

A transitional housing prototype in East New York, Brooklyn, has been adapted for a Westchester County suburb. Designed by Alex Cooper of Cooper, Robertson & Partners in 1988 for H. E. L. P., a New York State non-profit organization led by Andrew Cuomo, son of Governor Mario Cuomo, the Brooklyn project proved so successful that it was transplanted to the suburban site, in Greenburgh, N. Y. (top). Crucial to the formula are in-house social services such as counseling and day care. With security a driving force in the shoestring-budget design, the buildings are all walkups with covered-balcony walkways and private entrances to each unit. The 108-unit Greenburgh project, which like its predecessor shelters homeless families for up to six months while they get their lives together and find permanent homes, opened in April. Now Cooper—a H. E. L. P. director—has designed H. E. L. P. Homes, affordable rental housing (bottom) for 150 families, across the street from the first Brooklyn H. E. L. P. project. (H. E. L. P. operates 750 units serving 2,000 families a year.) The next move: a 100-unit apartment building is planned for lower Manhattan. *P. D. S.*

## California

# . . . Berkeley SRO

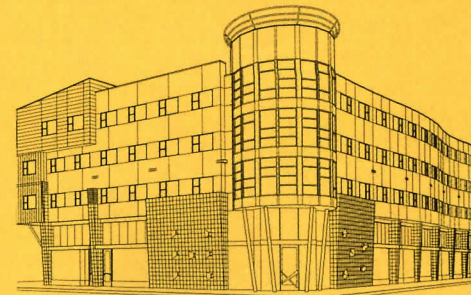

David Baker Associates squeezed local zoning to get 198 rooms of 175 sq ft each into Studio Durant, a 56,000-sq-ft, \$4.5-million single-room-occupancy hotel in downtown Berkeley. Baker used zoning precedents from similar projects in San Diego to get a reduction in allowable room size. Each room has a bathroom and kitchen, and, to stave off transients, residents must stay at least one month. Retail spaces at street level provide extra income; the developer-backed project uses no public financing. ■



# Meier, Rossi, Scott Brown and Venturi Add Fabrics to Their Futures



David Dubuque photos

With furniture sales and new-product development in a slump, furniture manufacturers are banking more on less-expensive-to-produce textiles. At WestWeek, Los Angeles's annual contract furnishings market held in March at the Pacific Design Center (PDC), fabric introductions—and their high-profile designers—stole the show.

The Knoll Group publicly unveiled its Peter Eisenman line with a party at the Los Angeles County Museum of Art, while DesignTex officially launched its all-star Portfolio collection by architects Richard Meier (above right), Aldo Rossi (above middle), and Robert Venturi and Denise Scott Brown (above left) with a full day of events. Festivities included the opening of "Three Directions and Three Dimensions" at the PDC's Murray Feldman Gallery, a traveling exhibition of three fabric pavilions embellished with photographs and drawings of the architects' buildings, and a two-hour panel discussion moderated by critic Peter Blake that covered, along with more substantive issues, the session's obscure title, "Metaphors: An International Zeitgeist." The day concluded

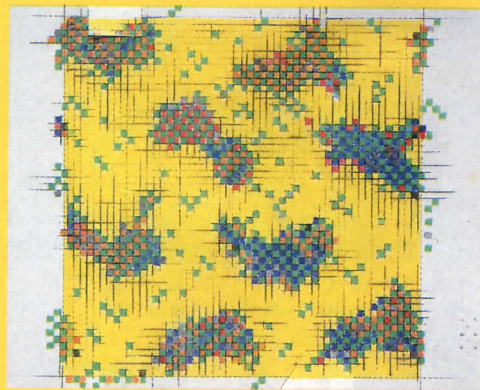

with the architects signing limited-edition lithographs of their drawings in a packed DesignTex showroom.

DesignTex conceived the Portfolio collection as a "compilation of the ideas and issues important to these architects in their three-dimensional work," according to the company's director of design Susan Lyons.

Not surprisingly, the results are as different as the architects' work. Meier's gridded Axiom (drawing above right) resembles a

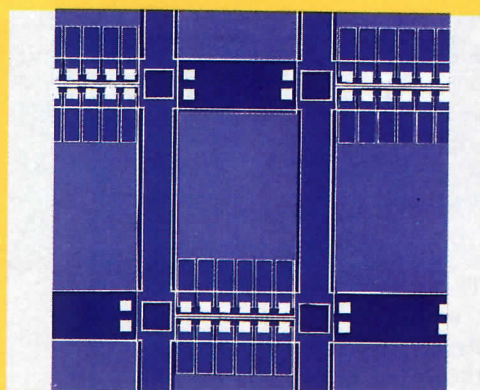

reflected ceiling plan, which DesignTex rendered in a mercerized cotton jacquard, while his satin-weave Abacus (middle sample in photo below) looks like the tidy wires and coils of a computer chip. Rossi reveals his painterly side in Italian Garden (bottom sample in photo below), a floral tapestrylike cotton jacquard that he said might do nicely in his own home. Marco Polo (drawing above middle) virtually replicates the Italian architect's doodle of colored squares on yellow trace in a polyester-cotton blend. Venturi and Scott Brown's cotton Gingham Floral (drawing above left) interweaves a small-scale black-and-white grid with oversized pastel-colored flower petals. With typical wit, the architects added bright polka dots to the traditionally sedate look of a cotton satin stripe and called it Staccato (top sample in photo left).



Roger Bester photo

While Portfolio gave Meier, Rossi, Scott Brown and Venturi the chance to indulge in something new, the 12-piece collection is hardly an excessive undertaking. As planned, the fabrics are moderately priced, beginning at \$35 a yard. *K. D. S.*

These construction firm of Kumagai Gumi Co., Ltd., has endowed the Kumagai Professorship of Architecture at Harvard's Graduate School of Design.

## Projects

Mario Botta is hoping for city approval of his first commercial project in Italy, headquarters for *La Provincia*, a newspaper based in the northern city of Como (below). The architect was selected because company officials believe he continues the tradition of the master builders of the Duomo at Como. The three-story newspaper complex, including a masonry-clad, symmetrical office building, is separated from a printer by an open space that allows light into the offices. The buildings are linked by an auditorium on the west. ■

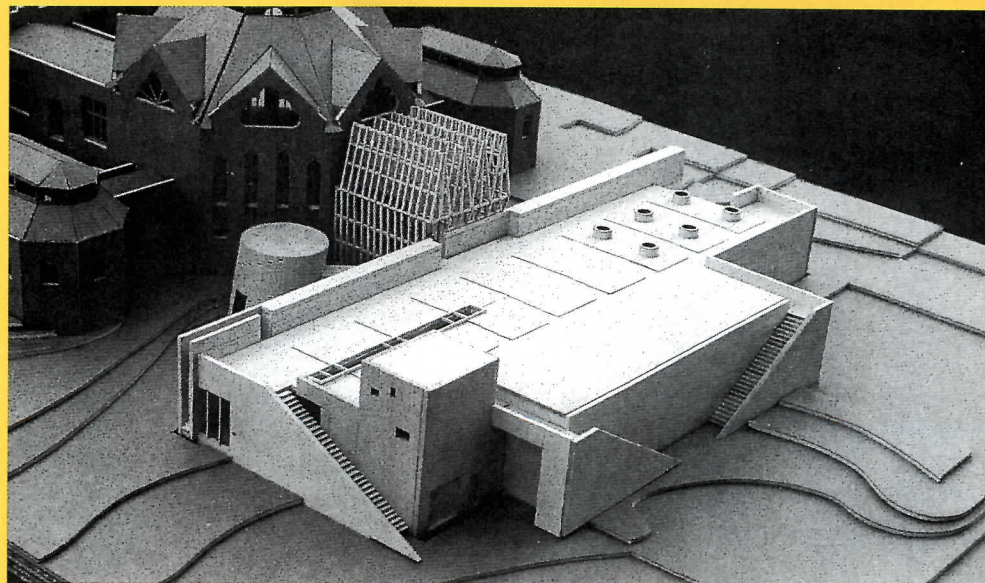

The proposed Chancellor Green Campus Center at Princeton University creates a

areas. Designed by Diana Agrest and Mario Gandelsonas, the 15,000-sq-ft building ad-

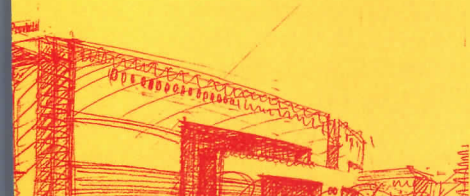



Over 90 percent of participating NEOCON showrooms will display new contract designs June 11 to 14, a constructive reply to this year's economic challenges.

For more information, circle item numbers on Reader Service Cards.

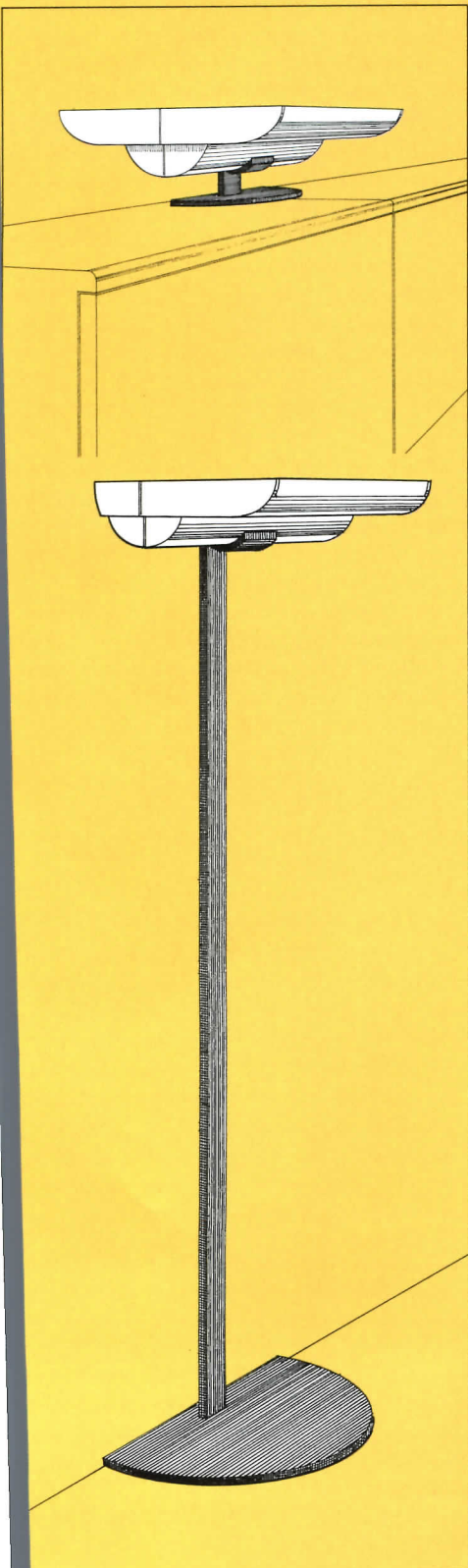

303



306



304



305

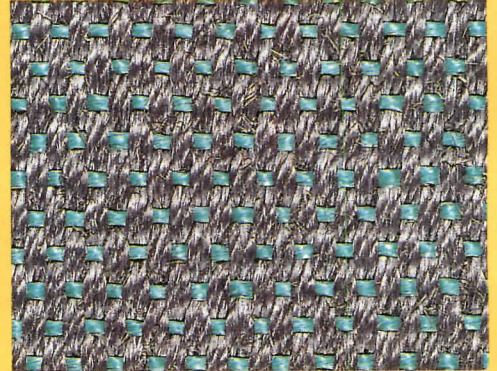

307



# NEOCON: Otto Zapf for Allsteel



## 308. Backing off from the hard edge

German ergo-guru Otto Zapf says he has been considering his ideal of a humanistic, comfortable office for almost a decade, thinking of what he would do if he could start over again. For the past four years, Allsteel has been giving him that chance. This June at NEOCON, Zapf, together with textile designer Deepa Thomas and their design and production team, will introduce Aurora, a new panel-based system that they see as a cost-efficient amalgam of market-driven user concerns, state-of-the-art ergonomic and productivity standards, and domestic warmth.

As Zapf's sketches below suggest, the system's design signature is its rounded edges, multiple 20-degree radius curves used on worksurfaces, panel trim, and drawer pulls. At 3 inches, the panels themselves are thicker than usual, giving them a solid feel and providing a larger interior space for wiring. Flowing laminate worksurfaces have a user-friendly edge of color-matched molded vinyl; another trim option offers the panache of a wood bullnose. Finish colors, laminates, natural- and composite-wood veneers, and new fabrics for panels and seating have been coordinated by Deepa Thomas of Deepa Textiles.

Zapf's major technical problem was power: how to get to it and how to connect it between panels. The solution (patent pending) permits four degrees of connecting electrical and communications wiring within a basic panel: under the top cap, under the base plate, through the panel's center core, or through the end caps. Both horizontal and vertical chases permit electrical and data access any place on the face of the panel. All panels are wire-capable.

Panel design permits fabric, wood, glass, and acoustical inserts in flexible 12-in. increments. Workstation assemblies are detailed by accent strips in any of 12 colors, which are easily replaced to update the office as carpet or wall colors change. Allsteel plans to offer short lead times on the Aurora line thanks to a manufacturing process based on work cells, which permits dissimilar operations simultaneously on a single component. Allsteel, Inc., Aurora, Ill. ■

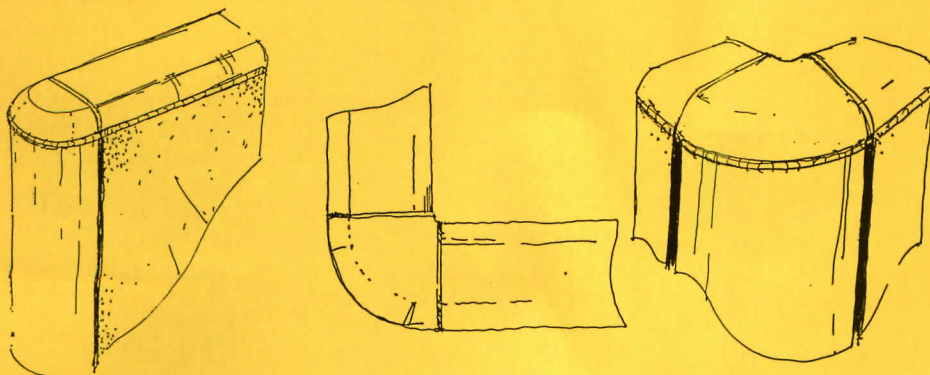



## Miminal-hardware Fire Doors

**309. Flush face.** Openings, Inc. makes the Total Door, single-, pair-, and double-egress systems that do not need vertical rods, floor hardware, coordinators, astragals, or flush bolts to meet fire ratings, even for a three-hour label. Wood veneer, laminate, stainless-steel, and polyurethane finish options may be specified for any door at any rating. Concealed latching mechanisms and hinges and almost-flush operators give the doors a smooth appearance particularly suitable for public areas where looks are important. For example, the elevator-lobby application below is a 1 1/2-hour-door pair with 180-degree swing, held magnetically in a pocketed installation. The unobtrusive, flush operating push-plate has the same rosewood finish as the door body. The cross-section (bottom) illustrates how a locking channel on the door itself works with a full-length jam-mounted catch stop, cocking open as the door handle is turned. (The wood-tone indicates the top, interior rail of the core.) Continuous concealed hinges are non-weight-bearing. All hardware is said to withstand demanding traffic conditions, and meet accessibility codes. Openings, Inc. ■

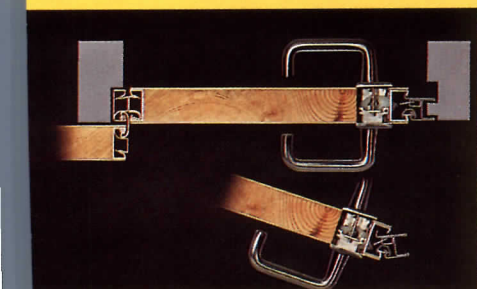

## New Furniture from the U. K.



310

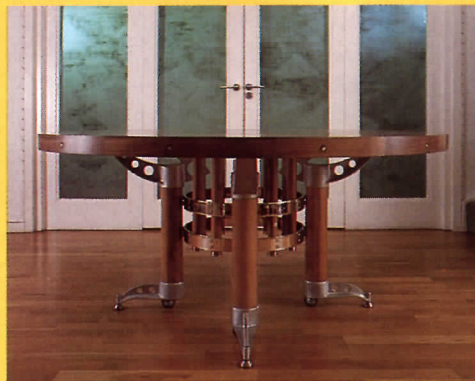

311

The third International Contemporary Furniture Fair, slated for New York City this month, (see Calendar for information) will feature a 14-firm-strong British contingent under the aegis of the Crafts Council.

**310. Windfall.** Reflecting his concern for making best use of the rare wood felled by Britain's 1987 gales, John Makepeace built this pier table with a curved base of laminated holly and a top of oystered mulberry (bird's-eye, to us). Parnham House.

**311. Constructionist.** Commissioned for a specific seen-from-above space, an expandable dining table uses shot-peened and sand-cast aluminum, etched glass, polished and stainless-steel, and oak and walnut wood. Nicholas Pryke Furniture.

**312. Glaswegian.** Part of the Tartanalia range by the Scottish design firm Graven Images, the Alexandra club chair would be at home in Hill House. Frame is stained ash; upholstery is leather, Nice House.

**313. Moderne.** The chrome curves and



312



313



314

leather cushions of Stephan Preisig's Ascari armchair are made by batch production, his own 'efficient coordination of highly specialist craftspeople'. Tribeca Designs.

**314. Marked.** Rupert Senior and Charles Wheeler-Carmichael will exhibit their Black Desk of wenge and English sycamore, awarded a Guild Mark by The Worshipful Company of Furniture Makers for excellence in craftsmanship and design. Whitehouse Workshops.

*Product News continued on page 123*



# Biting the Bullet

*Part three of a series on automation in practice.*

*By Kristine Fallon*

The second article in this series [RECORD, February 1991, pages 50-56] listed the four ingredients of automation planning: networking, scanning, multimedia computing, and training methods. This article presents actual experiences of design professionals with networking and scanning.

## **Networking multiple computer applications**

Marmon Barclay Souter Hays has 50 people and plans architecture, engineering, and interiors in a single office in San Antonio. In late 1989, the partners, having secured a big commission, started to evaluate where they stood in computer technology and to develop a phased plan for upgrading their administrative, financial, marketing, and technical systems.

Harvey Marmon, Jr., A. Tedford Barclay, Jr., Stephen Souter, James Foster, and William Hays, Jr. agreed on goals: to use computer technology in an up-to-date and competitive manner, and to do so cost effectively. This meant saving their existing investment in computer hardware and software and—more important—ensuring that their staff was comfortable with any changes in production and applications.

They enlisted the whole staff in a review of existing systems: CAD with McDonnell Douglas GDS software running on two Tektronix terminals connected to a MicroVAX I, which also ran a Calcomp pen plotter; a word-processing system with three terminals that was used for general correspondence, specifications, and marketing materials; a single PC-XT running Harper and Shuman's MicroCFMS for financial management, and a PC-AT clone used by the engineers for calculations and to connect with service bureaus for major engineering analyses. The PC-AT was also used for cost estimating and to handle the overflow on specifications production.

These systems were overloaded and underpowered. With the exception of the PC-AT, none of the workstations was multipurpose: i.e., a CAD station could not be used to work on specifications. The result was bottlenecks, not enhanced productivity.

## **Game plan**

The firm members decided to select and use hardware, software, and a network that would allow for inexpensive modular expansion. They looked for products that were mainstream and that allowed multiple uses so they would not be at a dead end in five years. They were familiar with Digital Equipment Corp. hardware and the VMS operating system, so they chose to stick with DEC for networking. They installed a VAX Server 3100 with 360-megabyte disk to manage an Ethernet network using DECnet protocols. They also chose DEC's Personal Computing Systems Architecture software to permit their PCs to use the VAX Server 3100 as an application and file server. Since DEC can serve PCs and Macintoshes and UNIX workstations, the firm was confident that its hardware options would remain open.

The choice also gave the firm some time to resolve the most highly contested issue—whether to stick with GDS or convert to AutoCAD. The architectural group liked GDS, but the engineers wanted AutoCAD because of the third-party programs that interfaced with it. AutoCAD was installed on two new 80386 machines as a trial. If AutoCAD won, more 386s could be purchased and files could be shared via the network. If GDS won, VAX stations could be added to the network and the 386s devoted to engineering. The VAX Server and DECnet environment supported either scenario. Plotting from two different systems would be difficult, but it was decided to use an outside service for AutoCAD plotting initially.

The partners planned to increase the number of administrative staff members as well as the number of word-processing machines, and to put them in a PC network. Two immediate concerns: to eke a little more production out of the existing system, they added a larger hard disk, left specifications on that system, and moved general correspondence to PCs. And because Mac excels at desktop publishing, runs the same word-processing software as the PCs, reads PC-formatted diskettes, and networks with the PCs and VAX, the partners chose it for marketing.

That left financial applications, which required more computer power, more disk capacity, and multiuser access to software. At first, the partners thought about moving to the VAX version of CFMS, which would run on the VAX Server. The cost of the VAX software upgrade, however, was more than 10 times that of an upgrade to a multiuser version of MicroCFMS. The multiuser version of MicroCFMS was chosen, to be installed on the network using the VAX Server as the file server.

All of this was to happen by the end of 1990. In early 1991, the partners stopped to see how far they had come.

They had gone further than the plan had anticipated in adding new hardware and phasing out old systems. The server and network were in place. They had also faced the most problematic choice and phased out GDS. The old word-processing system was hardly used at all, once the administrators got used to WordPerfect on 286 PCs. Most of the word-processing stations were already networked, as were the two 286 machines running MicroCFMS. Seven PCs were networked, and managing disk space on the Vax Server, especially for the MicroCFMS program, was already becoming an issue.

## **Lessons learned**

The first and foremost issue, says principal Jim Foster, is to resolve problems when multiple suppliers are involved. "You really need someone in-house to do the troubleshooting." One problem, says troubleshooter Greg Houston: large suppliers—DEC, IBM—seldom handle installations of small systems directly; they subcontract to a local consultant or reseller who often lacks the supplier's expertise.

The firm has also learned how vital both hardware and software reliability are in a networked environment. Members have worked through a number of problems with the multi-user version of MicroCFMS and hope to see everything functioning smoothly once Harper and Shuman release a DEC-specific version. One recurring problem, however, was causing the server to crash rendering the network inoperative. Other



*Scanned original plans by Frank Lloyd Wright for Hollyhock House allowed Los Angeles city architects to overlay red vector hvac plans in their renovation.*

problems: finding the time for AutoCAD training. The firm has tried video training, formal CAD classes, and intensive seminars. So far, the intensive seminars have worked best.

Were there mistakes in the plan? The only regret is the money spent on extending the life of old systems. Looking back, says Foster, "I wouldn't have upgraded the old word-processing system. I'm glad we didn't upgrade GDS." Overall, he says, theirs has been a good master plan. "We can grow incrementally as budget permits each year. I want to get to the point where even I have a workstation."

#### **Scanning in the Los Angeles Bureau of Engineering's architectural division**

The division resembles a large architectural-engineering firm with 70 to 100 architects, landscape architects, and electrical, mechanical, and structural engineers. It handles a full 50 percent of city design work and the staff also serves as project managers to interface with the outside consultants hired for larger projects. About 80 percent of the division's in-house design work is alterations and improvements of some 1,000 city-owned facilities.

Principal architect Paul McCarty is convinced that the integration of scanning with CAD is essential to keeping up with his staff's hefty workload in a time of tightening municipal budgets. His goal: a minimum of 50 percent of staff fully up to speed with both scanning and CAD by the end of 1991. Based on a thorough evaluation and detailed technical benchmarks for its own needs, the division chose Series 5000 CAD software from Auto-trol Technology, networked CAD workstations from HP/Apollo, and scanning gear from Optigraphics. It now has nine CAD workstations and an E-size scanner.

Auto-trol Technology, beside providing the CAD software, linked the HP/Apollo workstations with the scanners, as well as with PCs and a variety of printing and plotting devices from many suppliers. Plans exist to tie the entire CAD network into the city's IBM mainframe as well. One major challenge was to connect the Optigraphics scanning equipment, run over Ethernet, into

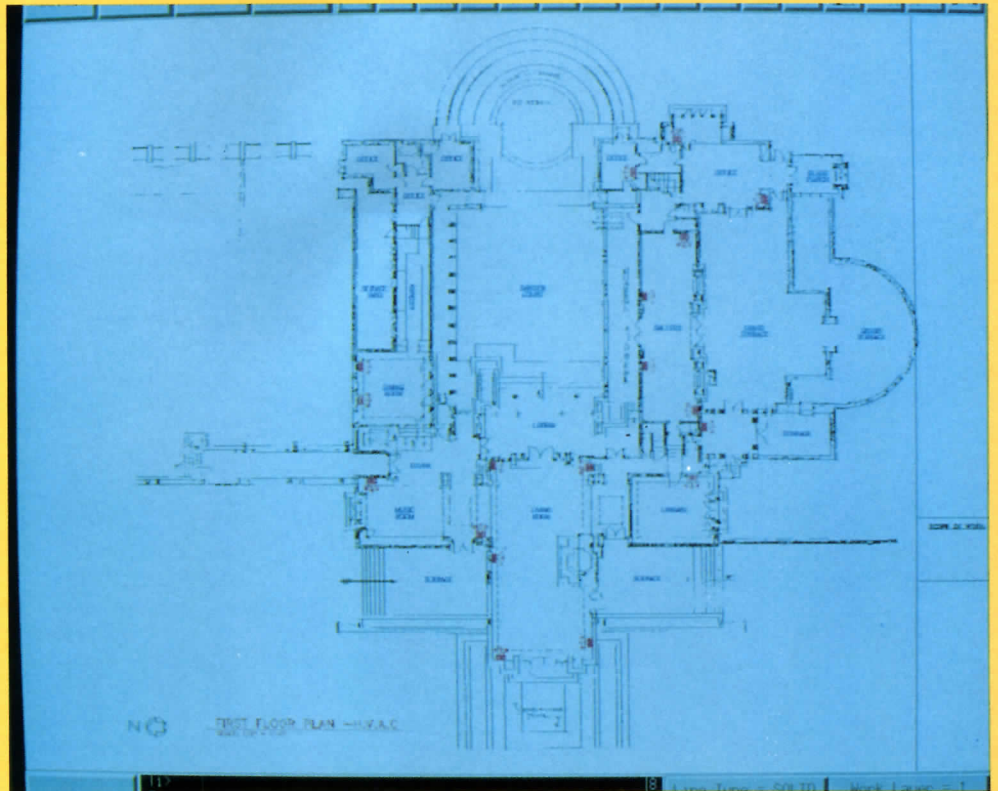

the HP/Apollo Token Ring network. Since HP/Apollo workstations support both Ethernet and Token Ring networks, one of the division's HP/Apollo is connected into both networks, acting as a "gateway" to provide two-way translation between the Ethernet and Token Ring protocols. Moving a scanned drawing from Ethernet, through the gateway and across the Token Ring network to their CAD workstation, is more foolproof than copying a file from a hard drive to a floppy.

#### **How LA's scanning works**

A major benefit of scanning is that users can move almost instantly from a drawing on paper to a CAD image. The steps:

1. Load the original into the scanner.
2. Run the scan. This process is like running a print.
3. Delete unwanted information, such as the old title block.
4. Copy the scanned image from the Ethernet network to Token Ring network.
5. Convert the scanned image into the format compatible with the Auto-trol system with an automated procedure.

6. Move the converted image to the proper disk and directory on the Token Ring network.

7. Begin working with the image on CAD.

Auto-trol Technology has provided CAD software to architects since the mid-1970s. In 1989, it introduced its Composite Image product, which permits users to combine CAD vector data with raster (scanned, dot pattern) images to create a single drawing. Any portion of the scanned image can be re-scaled, rotated, erased, moved, or duplicated. To add new information to the scanned image, normal CAD commands are used. The resulting composite image can be edited and plotted as a single drawing, or the vector and raster components can be manipulated separately. The system "remembers" the precise registration of the CAD-generated vectors with the scanned data.

The use of scanning is particularly appropriate on projects for which there are minimal architectural changes and additions or alterations to mechanical and electrical systems, says Rebecca Abano, an architectural assis-



## Finding Commissions

*continued from previous page*

tant and CAD coordinator for the architectural division. Another excellent application of scanning, she says, is for minor architectural modifications required for handicapped access.

### How LA got into scanning

One reason that the entire Bureau of Engineering is so committed to scanning technology is a history of success with innovative uses of scanning in the waste-water-systems engineering division. In 1988, before the major CAD suppliers supported raster images, the city was under court order to end pollution from waste-water spillage. That meant building new treatment facilities at record speeds. The engineers chose as a model a recently built facility that was functioning well and had been built with next to no problems. The set of documents for the facility was deemed superior, but had been produced manually on nonstandard-sized sheets. The engineers evaluated a number of scanning systems and chose Optigraphics. "It was really difficult to find products, and some of the suppliers we looked at went out of business before we could make a selection," says Paul Flygar, now CAD system manager for the engineers.

At that time Optigraphics supported scanning, raster editing, and some basic vector drawing, but not full-function CAD capability. Using this limited set of tools, the engineers scanned the drawings of the model treatment facility as well as the topographic drawings for the next site. The new facility was the mirror image of the original, so the scanned drawings were reversed and made to fit standard-size sheets. By cutting, pasting, scaling, and overlaying scanned images, as well as doing some vector drawing, the engineers managed to produce a 500-drawing set of construction documents in less than a year, an enviable accomplishment.

Now that major CAD suppliers do support raster, productivity should increase. For public and private organizations that own and maintain facilities, scanning is rapidly becoming an essential part of automation planning. ■



Rick Gore

*The firm's Dorothy Fuqua Conservatory.*

*An anomaly among architectural firms, Heery International is in the process of becoming wholly owned by a publicly traded British engineering conglomerate, BICC. George Heery was once CEO and head of design services, but has since gone out on his own. Joe Harris, one of the founders of Clark Tribble Harris & Li, now heads design services—a job that heavily involves sales. He offers these marketing insights:*

- *Capturing clients is a one-on-one process, no matter the design firm's size.*
- *Costly marketing materials must be kept in check, but still be effective. Computers can help you do this.*
- *A design firm can produce quality work and still be run for a profit. Strong capitalization can help you do this.*
- *Making fees clear to clients is good business. Do not start on a handshake.*
- *Look for work where you are needed.*

### Proven approach, new clients

*Harris:* The most difficult thing is getting used to the difference between the two firms. At Clark Tribble Harris & Lee, we were developers' architects and focused marketing on that one segment. At Heery, we focus on many—medical and athletic facilities, commercial and industrial buildings, corporate offices, and only to a small extent speculative construction. Now I must understand the differences in marketing to each. One answer is to have more people involved. Here we have someone heading medical-facilities marketing, another heading sports marketing and so on.

*George Heery:* In a centralized department or heading their respective departments?

*Harris:* Taking a cue from your book that marketing is magic, closing a sale is convincing individuals on a personal basis. So, the ultimate goal is to get me across the table. Marketing materials and marketing coordinators get me there. And I want to arrive built up at least equal to the competition. Then we can talk about me as an individual and the client as an individual. Each person who develops leads and brings people to the table is aided by one central marketing group.

### Streamlining marketing materials

We want to standardize them and make them as inexpensive as we can. But we also want to target them so they do the job. With computers, there is no longer reason to take materials off the shelf; they can be tailored for each project by the marketing coordinators. But the formatting and repetitious data can be the same. One consideration is that these data not become obsolete. Another is that our most recent building is most likely to make us equal to the competition and must be included.

Short forms work well for quick response but tailoring has to be extensive for the longer forms that answer an RFP. We map out these responses in a hard-bound book. Such packaging gives an impression of the time you put in. Still, to cut costs, you always ask, how can I do responses smarter?

### Personal approach, corporate climate

*Heery:* I never allowed anyone to put his name in a brochure, mine included—even though I had arguments from people who got major parts of the business.



Part four of a series. This month George and Laura Heery interview Joe Harris (photo below) for the inside story of how architects find clients.

**Harris:** Having four names on the door at Clark Tribble Harris & Lee helped me sell. I could sell that I'm Harris, my name is on the door, you can count on me to do the work. That was the direct sell—a simple approach. What I was willing to take on at Heery was to run a firm without my name on the door.

#### Using financial strength to advantage

**Heery:** Do you market BICC ownership?

**Harris:** What we have backing us is that we're not only here today, we will be here tomorrow. We are one of the few firms that is capitalized to have the latest equipment and expand into new markets.

**Heery:** Is your fee very much a part of the marketing problem?

**Harris:** That's right. And that's why we have to streamline. One of the tools capitalization has bought us is CAD. By planning our job before we start it, we can integrate CAD quickly. It can reduce the production manhours by a factor of 2 to 2.5 times. Where does that bonus go? Into our pocket? Unfortunately, since the fee is shrinking, that is not the case. It just gives us, within current fee structures, the money we need to market, organize, and operate.

**Heery:** But you are competing with other firms that get the same saving.



Joe Harris  
Photo by  
Anthony Hursley

**Harris:** It all comes down to using your resources effectively, especially CAD. When you analyze our business for places to save money, the challenge today is to bring in ever more efficiency and—in doing it—make our profit and reduce cost to the client.

#### First, settle on fees

**Heery:** I've noticed firms that work with the same developers start work with a telephone call. There are other firms that require whole new contracts and a lot of defining of the project before they start work. How do you handle it?

**Harris:** Even at Clark Tibble Harris & Lee where we worked with many developers and prided ourselves on fast production, we didn't start on a handshake. We always started any project on a firm understanding of what we would get paid. It could be verbal or in a letter. I'm more concerned with the real commitment than the document because my experience has been that, if you don't debate the fee and negotiate to a firm conclusion, they don't intend to pay you. And if they don't, no amount of contract documentation will make them. The simpler the contract, the better.

#### Knowing what clients want

I always want to think my fee is a little higher than the competition's. That says, I am going to give you more and you are going to benefit. People buy design. We discovered this in a survey of clients at Clark Tribble Harris & Lee.

But every client also wanted more service. It's like getting your film developed. It used to take a week. Now, you wait while they do it in an hour and you're upset because it takes so long. So, the amount of service you get is what you expect. Clients always expect service, as well as on time and in the money.

Architects take their blank paper and put design on it. That's what they sell. Even though clients think they know what they want, they don't. They are unable to do the magic in converting their ideas to solutions. What sets successful architects apart is producing a good concept within the confines of the opportunity an owner has given them.

#### Tailoring services

**Harris:** Understanding the differences in markets is critical. If you talk about doing the job really fast, you could frighten the corporate clients. For them, we want to make sure the design is thoroughly studied and absolutely correct. On the other hand, developer clients expect fast delivery because they are often dealing with a product they have dealt with before. They know their cost parameters; they know what they're doing. So, we can make decisions very fast. The architect cannot proceed faster than the client.

With developers, we take a look at the design opportunity and work it to get dollars focused on doing as much as possible. If developers are professionals, they want the right design product. That is why I want to get face to face and make the commitment to give it to them. It's good that developers have seen the value of design—and the signature.

#### Finding where he is wanted

Like everyone, we are always looking for places to provide a service where none exists. We go to markets where the quality of design is not as high as it should be. They're our target.

**Heery:** Because the developer market is not likely to be as buoyant in the next few years, the day of the owner/user may be returning. Corporations, instead of going to developers for a turnkey project, may be hiring their own designs for their own buildings. Do you agree?

**Harris:** The market is shifting. With tax-law changes, developers may use their expertise to assist owners in getting buildings built. But the market is going to be moving away from developer-owner marriages.

Charles K. Hoyt



## What's New in Quality Management?

By David Ballast

Although quality assurance and quality control have been buzzwords in the design professions for years, we are just beginning to see meaningful changes in ways to achieve the goal of improved quality.

### Shifts in meaning and means

Recently, attention to quality has shifted from isolated, sometimes perfunctory efforts such as improved document checking to a consideration of quality as a management function—not something that you delegate to project managers or other staff. Firms making the greatest strides in this area exact a total, continuous commitment to quality by using a wide variety of methods. Benefits include increased productivity, reduced liability, and retaining (or regaining) a competitive edge.

Even the definition of quality has grown sharper. Though there are variations, the essential definition of quality is conformance with the client's requirements. Within this definition are several implied conditions, such as ways in which the designer helps his client set requirements and how the design conforms to building codes. But the focus is on the client, not on what the architect or engineer thinks of as quality. Expensive materials or dressing a building in the current style do not necessarily equal quality.

There has also been a shift in emphasis from quality *control* to quality *assurance*. Quality control involves checking completed documents before they are issued, like plucking defective widgets from an assembly line. Quality *assurance* is getting the job right the first time and assuring that whatever level of performance has been agreed upon is achieved. Certainly a thorough final check and interdisciplinary coordination of drawings are still valuable, but the simple detection of a mistake does not indicate its underlying cause. A mistake in the document, even though redlined, almost surely will be repeated in execution.

Finally, responsibility for quality now actively involves everyone in a firm, rather than an individual or a single department. Even though senior management is committed to improving quality, it may not know of

all the problems nor of administrative barriers to solutions. These changes have occurred in much the same way that professional-services marketing did in the 1970s, when marketing was practically unheard in architects' vocabularies. Slowly, some architects and engineers started to organize their efforts to get work. Quality assurance seems destined to follow a similar path.

The impetus to improve quality arose in the early '80s with the liability crisis and the corresponding increase in insurance rates.

*Concern about quality has shifted from quality control—checking quality after documents are completed—to quality assurance—getting the job right the first time.*

Design professionals realized that they had to improve, if for no other reason than to stay out of court. Initial attempts focused on such techniques as design checklists, comprehensive document review, and dictates set forth in quality-control manuals. Since these did not always work, more was needed.

### Looking for roots

The most recent thinking has coalesced under the term "total quality management." TQM began after World War II with the teachings of W. Edward Deming, Joseph Juran, and others. At that time, their principles found few takers in U. S. industry. However, their ideas *were* adopted by the Japanese.

In this country, the TQM approach was adopted in earnest in the early '80s. Many large U. S. manufacturing industries have used the ideas of TQM for some time, and now several large architectural and engineering companies have started using it. Total quality management is based on Deming's 14 points for quality management (see box). While on first reading, some of Deming's guidelines may not seem appropriate for service businesses, they form the basis for the new directions many now take.

### Major TQM components for design firms

- *A commitment by top management to improve and lead by example.* Bill Hayden, a quality consultant to design and construction professionals, has found that more than 85 percent of quality problems can be traced to firms' organizational systems. He finds that in most cases good people and tools are available, but management does not use them or train employees in quality assurance. Often, management is not even aware of administrative barriers to improving quality.

- *Emphasis on the prevention of problems and improvement of work procedures, rather than just checking or correcting.*

Quality-assurance professionals know that the total cost of quality can be reduced by investing in doing the job right the first time.

- *Emphasis on customer satisfaction.* This is often difficult for architects to achieve because they have many "clients," such as the public and building users, in addition to the owner, but even the requirements of these secondary clients can be established with the owner early in the design process. The real danger is that the architect may work to his own idea of excellence while the client may have a completely different image of quality.

- *Involvement by everyone in the firm.* All staff members must improve the way they do their jobs.

- *Establishment of teams to identify problems and solutions.* In order for a quality improvement team to work, it must include everyone working on the job, since these are the people who know best what problems arise and how they might best be solved. The team should continue its work as long as the job lasts.

- *Recognition that the improvement of quality is a continuous process.* There is



## *Emerging trends begin to change architectural and engineering practice.*

easy road to quality and no time when the firm can say, "We've done it, we're finished." As do all worthwhile efforts, quality improvement takes time and costs money.

There are many additional ways to implement the various parts of a TQM program. These include in-house training for quality-assurance processes, as well as for such subjects as statistical methods and charting procedures to help pinpoint problems, the institution of a design-excellence awards program, and procedures for more-vigorous client selection in order to head off problems even before a contract is signed. In addition, many firms have found peer review a valuable practice. The American Institute of Architects has a peer-review program based on the procedures used by the American Consulting Engineers Council. Both organizations report that those who have been reviewed were well satisfied.

Regardless of which procedures a firm might use, however, one or two techniques used in isolation are bound to fail. Any firm that is serious about quality assurance must devise a comprehensive program.

### **Some who tried TQM**

A total quality-management program was recently undertaken at the architectural and engineering firm TAMS Consultants. Richard Simon, director of corporate quality, leads the effort, along with 23 appointed coordinators in the company's various offices and departments responsible for the program. Actions include educating employees, auditing selected projects, enlisting employees in the improvement of project reviews and time sheets, and upgrading the quality-assurance manual. Because TAMS's program is less than a year old, it is too early to realize a dollar payback, but Simon believes that the company will see improved service and increased profitability.

Another firm active in TQM is BSW Group, Inc., in Tulsa. Because most of its clients are companies with continuing building programs, the firm's system includes process-management workshops held with major clients. These take place over several days before a project gets started, so that both sides can clearly define requirements and

agree on the project-delivery system. Quality-assurance techniques include a system that finds flaws in prototype buildings before mistakes are repeated. The firm is also reorganizing its specifications studio into a document-management studio responsible for coordinating documents throughout the firm.

These efforts do not take place in a vacuum. In July 1989, the Design and Construction Quality Institute was formed in order to promote total quality management in the planning, design, construction, operation, and maintenance of the built environment. As part of its activities, the institute provides a forum for people with an interest in design and construction to examine issues of quality, and it provides resources for education and training and promotes public awareness of TQM. It also holds an annual conference and publishes a quarterly newsletter. The institute has offices at 1015 15th Street, N. W., Suite 802, Washington, D. C. 20005 (202/347-7474).

If architects and engineers are to improve the quality of their services and remain competitive, large and small firms alike will have to reassess their management structures. More comprehensive quality-assurance programs will add another dimension of office administration and will demand management commitment. However, the potential payoffs are great, and the ultimate choice may simply be to improve quality or perish.

### **Suggested reading:**

*Quality Planning and Analysis*, second edition, by J. M. Juran and Frank M. Gryna, Jr. New York: McGraw-Hill, 1980.  
*Quality Without Tears*, by Philip B. Crosby. New York: McGraw-Hill, 1984.  
*Total Quality*, by the Ernst & Young Quality Improvement Consulting Group. New York: Dow Jones-Irwin, 1990. ■

### **Dr. W. Edward Deming's 14 points for Quality Management**

- 1.** Create a constancy of purpose toward improvement of product and service.
- 2.** Adopt the new philosophy.
- 3.** Cease dependence on inspection to achieve quality.
- 4.** Do not award business on the basis of price tag alone. Instead, minimize total cost. Move toward a single supplier for any one item based on a long-term relationship of mutual loyalty and trust.
- 5.** Improve constantly and forever every process for planning, production, and service.
- 6.** Introduce training on the job.
- 7.** Adopt and institute leadership.
- 8.** Drive out fear.
- 9.** Break down barriers between departments.
- 10.** Eliminate slogans, exhortations, and targets for the work objective. Substitute leadership.
- 11.** Eliminate quotas on the factory floor and management by objectives. Substitute leadership.
- 12.** Remove barriers that rob people of pride of workmanship. Eliminate the annual rating or merit system.
- 13.** Institute a vigorous program of education and self-improvement for everyone.
- 14.** Put everybody in the company to work to accomplish the transformation.



## Turned On

By Chuck Deakin

Architects and engineers do not respond to motivation efforts the same way other people do. Security is on their lists of priorities, but it ranks far below self-expression and variety of experience. At the same time, technological and legal developments continue to burden every project with more and more man-hours of effort; and, since theirs is a labor-intensive profession, productive use of each man-hour has become critical.

Combining architects' priorities with productivity means knowing the right inducements. These fall into three general and overlapping categories:

1. Wages with related fringe benefits.
2. Employee/employer interface.
3. Employee/project involvement.

### Wages/fringe benefits

Paychecks, fringe packages, and bonuses are the most expensive motivators and, paradoxically, have the shortest effectiveness. A raise, a bonus, or an added week of vacation will cause extra enthusiasm initially, but quickly fade. One answer is to reward individual performance with raises at irregular intervals, rather than on anticipated schedules. Rotate salary reviews on half-year anniversaries of employment for each individual, instead of doing a single end-of-the-year review for all. Still, the current local wage scale must be met and employees must be convinced that their pay is appropriate. Architectural employees worry more about being taken advantage of than the amount they are paid.

### Hourly wages vs. annual salary

Today, most architectural employees, hourly and salaried, keep hourly time records for billing purposes and job-cost management. The Department of Labor keeps redefining who may be classified as a salaried

*Mr. Deakin is an adjunct professor in the Tulane School of Architecture.*

*A veteran of managing large and small firms, including his own, writes about motivating staff. The first of two parts.*

professional, ever increasing the proportion that must be considered hourly employees. Any office can become a target for a finding against it, usually triggered by a complaint from an embittered employee.

Government pressure aside, it may be time for the profession to pay all employees at an hourly rate—with overtime as authorized. While this may seem unprofessional, our profession is man-hour based and payment in kind is appropriate and fair. For the employee, rewards for overtime generate a better attitude toward extra work. For the employer, they mean careful scrutiny as to its need. If project planning reveals that overtime is needed, it should be scheduled for the beginning of the job. This way a complete design-development package may be distributed to engineering consultants early.

To make the hourly-pay-plus-overtime method cost about the same as annual salaries, determine the real hourly rate employees have been paid over the past two or three years by dividing annual salaries by the average number of hours employees in various pay categories actually spent. Pay on that basis.

### Spot bonuses

Some offices reward overtime with year-end bonuses based on profitability. But it is the rare recipient who fails to calculate the low rate per overtime hour that the bonus represents. So, while adequately paid, they feel disillusioned. Try allocating the same money to a fund budgeted for use as *spot* bonuses. When an employee has excelled on a design, a sheet of drawings, a skillful handling of a client problem—give that person a cash bonus on the spot. It may energize the employee longer than an annual raise worth much more. Let everyone in the firm know about it. Motivate them to do likewise.

### Fringe benefits

Vacation, paid holidays, and medical insurance can be continuously motivating forces or simply taken for granted. A uniform fringe-benefit package usually has the least impact on productivity of any operating cost. Consequently, having the most generous fringe-benefit package in town is a poor motivational investment, unless imagina-

tively presented. For instance, the floating holiday is a strong motivator. While everyone in the firm receives the same one-day benefit, the importance of the individual is reinforced. Apply a flexible attitude towards all fringe benefits. Recognize that employees whose children are through college may prefer an extra week of vacation to a wage raise. For them, the extra week is the same as a tax-free raise.

The same management attitude can be applied to group health care and dental insurance. The office standard could be to pay half the premium. An increased share of payments and coverage for dependents is negotiable, and becomes still another recognition of individual needs. The insurance industry recognizes this variation in employee needs for health coverage and now offers a "cafeteria plan." The employer pays a fixed amount for each employee, but employees may choose the kinds of health coverage that best meet their needs—and increase their coverage at their own cost. While a firm's insurance broker may bear the expense of setting up such a customized plan, the firm's increased cost will be in processing individuals' new programs when their needs change.

### Physical environment

New work stations or painting the drafting room can, in themselves, be as short-lived motivators as changes in personal financial packages. One series of experiments set up to determine the illumination level for greatest productivity found that *any* change of light level increased productivity—for a time. A longer-lasting benefit of physical changes is increased pride in the firm. Green major changes with an open house for employees' family and friends.

When employees see that you care about their individual needs, you will be on the path to increased output and quality. ■

*The second half of this article will deal with inducements that cost less and may produce more.*



# 1991: The Turnaround Year

## Construction Economy Update

By George A. Christie

The *Outlook* for construction contracting in 1991 [RECORD, November 1990, pages 33-43] revealed the second stage of a fairly typical two-year cyclical decline of building activity. In year one—1990—the construction industry was knocked off its pedestal as the value of newly started projects plummeted 11 percent. That much was already history when the 1991 *Outlook* was first issued.

In year two—that's 1991—a secondary setback was anticipated, and still is. But unlike 1990's "free fall" when market conditions worsened with each successive quarter, 1991's smaller decline will be cushioned by a mid-year turnaround of the Dodge Index of construction contract value.

### Are we there yet?

The opening months of 1991 brought an indication that this year is going to be different. The first requirement for turnaround is to bring the decline to a halt, and some encouragement can be taken from the recent stabilization of construction contracting. The Dodge Index, once as high as 187 (in September, 1989) fell all the way to 133 by last December, but held that level through January and February. For two good reasons, however—one a general business recession and the other a credit crunch—a sustainable rebound of construction contracting isn't likely in the immediate future.

Assuming that this year's second quarter will bring the conclusion of the 1990/91 decline of construction contracting, one issue that can be put to rest is: How does this current cyclical reversal compare with previous ones? If second quarter 1991 turns out to be the bottom of the current cycle, comparison with previous declines shows this one to be less severe than the average duration, but not as deep (from peak to trough, 25 percent vs. an average of 40 percent). Some special features of the last (early 1980s) decline not evident in the current situation help to explain the greater severity of that crash.

That decline occurred during context of a considerably more formidable general recession than the 1990/1991 "mild" setback. It was intensified by a highly restrictive monetary policy that had the effect of trading

double-digit interest rates for double-digit inflation. This time around, the Federal Reserve has been pushing interest rates down. The earlier construction recession, like that of the economy at large, was a "double-dip" event. A short-lived recovery, which began in 1980 soon aborted, and contracting sank back to an even lower trough in 1982. The entire two-part recession of the early 1980s spanned a total of 15 quarters before sustained recovery took hold in 1983.

The current construction recession has a few special features of its own which are worth bearing in mind. All of the decline has been confined to privately financed construction (housing and commercial/industrial building). Publicly funded work (infrastructure and institutional building) came through 1990 and 1991 unscathed, and served as a market stabilizer through the downturn. The 1990/91 recession was something of a bicoastal phenomenon. Led by the collapse of building in the Northeast, the two eastern regions and the western region took two-year declines of 22 percent and 13 percent, respectively. By contrast, the central regions collectively lost only 6 percent of their 1989 construction market through 1991.

### The view from the valley

To sum up as of spring 1991, the decline of contracting for new construction has probably bottomed out, but recovery is still a few months away. Beyond the immediate issue of a turnaround is the question of how strong a recovery will be when it gets here. That's a subject to be considered in the *1992 Outlook*. The main business for 1991 is getting out of the valley.

Successful conclusion of the Gulf War removes one variable from the outlook equation and helps to clarify another. It never was clear exactly what bombing in Baghdad had to do with building in Birmingham apart from its negative psychological tie-in (i.e., uncertainty inhibits decision making). Nevertheless, the restoration of what passes for peace in the Middle East lends credibility to the widely accepted expectation of an early recovery from the general recession of 1990/91. With the energy component of the CPI dormant for the time being, a period of acceptable inflation leaves the

Federal Reserve in a position to provide the monetary stimulus needed to guide the economy out of its slump.

As a leading indicator of general economic activity, construction contracting should be on its way up before the less sensitive GNP data confirm that the economy has snapped out of its recent recession. And if, as it is generally believed, the economy's upturn is due in the third (or fourth) quarter, construction's bellwether single-family-house building industry would ordinarily get there first. There is, however, one other important condition to be met, and that is an easing of the credit crunch of 1990. It does little good for the Fed to push interest rates down as long as lenders continue to boycott real-estate development.

### Getting past the crunch

What began in 1989 as a savings-and-loan crisis turned into a general credit crunch in 1990 when commercial banks were subjected to controls similar to those applied earlier to the S&Ls (as mandated by FIRREA). The regulatory clampdown on commercial banks, unlike the reform of the scandal-ridden thrifts, was largely precautionary (and perhaps even an over-reaction) but the result was similar. The requirement that commercial banks restructure their real-estate portfolios, set up reserves against "nonperforming" loans, write down overvalued real-estate holdings, and improve their capital-to-loan ratios brought heavy losses in 1990's final quarter. It also led to the virtual paralysis of real-estate finance.

There is no quick fix for the credit crunch of 1990/91. Perhaps the best that can be said is that 1990 was the time of maximum regulatory stress for the banking system. Nevertheless, with delinquencies and repossessions still rising during 1991's recessionary environment, lenders are motivated to get out of, rather than more deeply into, real-estate development. And even as the crunch eases, its consequences for the building business are all too obvious. Unlike the early and middle 1980s, when lenders were recklessly eager to back real-estate deals with few questions asked, they will be erring on the side of conservatism and selectivity.



### Watch these in 1991

Two major categories of construction will be especially handicapped by the 1991 environment of scarce credit and a weak economy. One of them is housing; the other, retail building.

Sensitivity to both credit scarcity and to the uncertainty that goes with rising unemployment makes housing this year's nominee for the most vulnerable building category award, at least for the first half of 1991. As the year opened, both single-family and multifamily housing markets were in a deeply depressed state, although not for the same reasons. A general reluctance of lenders to back residential building of any kind is, of course, impacting both housing markets at present. Unfortunately, the eventual improvement of credit availability will be of little benefit to the troubled apartment/condo market in which building has been declining steadily for the past five years under good credit conditions and bad.

Until the oversupply created during the mid-1980s tax-shelter boom is significantly reduced—and progress to date has been painfully slow—new starts will not exceed 300,000 units per year. Potential, once the multifamily vacancy rate returns to its traditional 5 percent, is in the vicinity of 500,000 units.

In contrast to the distorted apartment/condo market, single-family houses are fundamentally sound. Until it was temporarily shut down by 1990's credit crunch, single-family demand averaged a steady one million units per year from 1983 through 1989—proof of the solid demographic foundation this market enjoys.

In 1991, single-family building will be responding to market conditions in two ways: *negatively* in the first half when recession and credit scarcity dominate, and *positively* in the second half as credit eases and the economy resumes an upward path. Although the second-half rate of starts, at 875,000 units, could exceed the first half's weak 750,000 rate by as much as 15 percent, the change will not be quite enough to prevent another small decline for the full year. More important than that, the second-half rebound

## 1991 National Estimates Dodge Construction Potentials

First update 3/21/91

	1990 Actual	1991 Forecast	Percent Change 1990/91
<b>Nonresidential Buildings</b>			
<b>Floor Area</b> (millions of sq. ft.)			
Office Buildings	157	125	-20
Stores and Other Commercial	479	380	-21
Manufacturing Buildings	120	115	-4
<b>Total Commercial and Mfg.</b>	<b>756</b>	<b>620</b>	<b>-18</b>
Educational	142	138	-3
Hospital and Health	68	66	-3
Other Nonresidential Buildings	149	146	-2
<b>Total Institutional and Other</b>	<b>359</b>	<b>350</b>	<b>-3</b>
<b>TOTAL NONRESIDENTIAL BUILDINGS</b>	<b>1,115</b>	<b>970</b>	<b>-13</b>
<b>Contract Value</b> (millions of \$)			
Office Buildings	\$ 16,748	\$ 14,400	-14
Stores and Other Commercial	22,979	19,150	-17
Manufacturing Buildings	7,326	7,275	-1
<b>Total Commercial and Mfg.</b>	<b>\$ 47,053</b>	<b>\$ 40,825</b>	<b>-13</b>
Educational	\$ 15,414	\$ 15,500	+1
Hospital and Health	8,937	8,950	—
Other Nonresidential Buildings	15,573	15,550	—
<b>Total Institutional and Other</b>	<b>\$ 39,924</b>	<b>\$ 40,000</b>	<b>—</b>
<b>TOTAL NONRESIDENTIAL BUILDINGS</b>	<b>\$ 86,977</b>	<b>\$ 80,825</b>	<b>-7</b>
<b>Residential Buildings</b>			
<b>Dwelling Units</b> (thous. of units)			
One Family Houses	841	815	-3
Multifamily Housing	292	235	-20
<b>Total Housekeeping Residential</b>	<b>1,133</b>	<b>1,050</b>	<b>-7</b>
<b>Floor Area</b> (millions of sq. ft.)			
One Family Houses	1,500	1,460	-3
Multifamily Housing	315	253	-20
Nonhousekeeping Residential	51	42	-18
<b>Total Residential Buildings</b>	<b>1,866</b>	<b>1,755</b>	<b>-6</b>
<b>Contract Value</b> (millions of \$)			
One Family Houses	\$ 84,033	\$ 83,675	—
Multifamily Housing	16,779	14,200	-15
Nonhousekeeping Residential	4,597	4,075	-11
<b>Total Residential Buildings</b>	<b>\$105,409</b>	<b>\$101,950</b>	<b>-3</b>
<b>Nonbuilding Construction</b>			
<b>Contract Value</b> (millions of \$)			
Transportation Construction	\$ 24,558	\$ 26,325	+7
Environmental Construction	20,280	18,475	-9
<b>Total Public Works</b>	<b>\$ 44,838</b>	<b>\$ 44,800</b>	<b>—</b>
Utilities	\$ 4,337	\$ 4,300	-1
<b>TOTAL NONBUILDING CONSTRUCTION</b>	<b>\$ 49,175</b>	<b>\$ 49,100</b>	<b>-1</b>
<b>All Construction</b>			
<b>Contract Value</b> (millions of \$)			
<b>Total Construction</b>	<b>\$241,561</b>	<b>\$231,875</b>	<b>-4</b>
Dodge Index (1982=100)	154	148	-4



## 1991 Regional Estimates Dodge Construction Potentials

Construction Contract Value (millions of dollars)	1990 Actual	1991 Forecast	Percent Change 1990/91	1990 Actual	1991 Forecast	Percent Change 1990/91	
<b>Northeast</b> CT, ME, MA, NH, NJ, NY, PA, RI, VT							
<b>Nonresidential Building</b>			<b>Residential Building</b>				
Commercial and Manufacturing	\$ 8,343	\$ 7,350	-12	One Family Houses	\$ 9,924	\$ 9,925	—
Institutional and Other	8,729	8,225	- 6	Multifamily and Nhskpg.	3,622	3,300	- 9
<b>Total</b>	<b>\$17,072</b>	<b>\$15,575</b>	<b>- 9</b>	<b>Total</b>	<b>\$13,546</b>	<b>\$13,225</b>	<b>- 2</b>
<b>Nonbuilding Construction</b>	<b>\$ 9,663</b>	<b>\$10,075</b>	<b>+ 4</b>	<b>TOTAL CONSTRUCTION</b>	<b>\$40,281</b>	<b>\$38,875</b>	<b>- 3</b>
<b>North Central</b> IL, IN, IA, KS, MI, MN, MO, NE, ND, OH, SD, WI							
<b>Nonresidential Building</b>			<b>Residential Building</b>				
Commercial and Manufacturing	\$11,543	\$10,200	-12	One Family Houses	\$17,764	\$17,875	+ 1
Institutional and Other	9,253	8,925	- 4	Multifamily and Nhskpg.	4,464	3,725	-17
<b>Total</b>	<b>\$20,796</b>	<b>\$19,125</b>	<b>- 8</b>	<b>Total</b>	<b>\$22,228</b>	<b>\$21,600</b>	<b>- 3</b>
<b>Nonbuilding Construction</b>	<b>\$10,804</b>	<b>\$10,925</b>	<b>+ 1</b>	<b>TOTAL CONSTRUCTION</b>	<b>\$53,828</b>	<b>\$51,650</b>	<b>- 4</b>
<b>South Atlantic</b> DE, DC, FL, GA, MD, NC, SC, VA, WV							
<b>Nonresidential Building</b>			<b>Residential Building</b>				
Commercial and Manufacturing	\$ 8,968	\$7,525	-16	One Family Houses	\$20,216	\$19,425	- 4
Institutional and Other	7,501	7,675	+ 2	Multifamily and Nhskpg.	4,616	3,825	-17
<b>Total</b>	<b>\$16,469</b>	<b>\$15,200</b>	<b>- 8</b>	<b>Total</b>	<b>\$24,832</b>	<b>\$23,250</b>	<b>- 6</b>
<b>Nonbuilding Construction</b>	<b>\$ 8,504</b>	<b>\$ 8,250</b>	<b>- 3</b>	<b>TOTAL CONSTRUCTION</b>	<b>\$49,805</b>	<b>\$46,700</b>	<b>- 6</b>
<b>South Central</b> AL, AR, KY, LA, MS, OK, TN, TX							
<b>Nonresidential Building</b>			<b>Residential Building</b>				
Commercial and Manufacturing	\$ 5,625	\$ 5,375	- 4	One Family Houses	\$10,926	\$12,575	+15
Institutional and Other	5,187	5,825	+12	Multifamily and Nhskpg.	1,324	1,325	—
<b>Total</b>	<b>\$10,812</b>	<b>\$11,200</b>	<b>+ 4</b>	<b>Total</b>	<b>\$12,250</b>	<b>\$13,900</b>	<b>+13</b>
<b>Nonbuilding Construction</b>	<b>\$ 8,370</b>	<b>\$ 8,350</b>	<b>—</b>	<b>TOTAL CONSTRUCTION</b>	<b>\$31,432</b>	<b>\$33,450</b>	<b>+ 6</b>
<b>West</b> AK, AZ, CA, CO, HI, ID, MT, NV, NM, OR, UT, WA, WY							
<b>Nonresidential Building</b>			<b>Residential Building</b>				
Commercial and Manufacturing	\$12,574	\$10,375	-17	One Family Houses	\$25,202	\$23,875	- 5
Institutional and Other	9,254	9,350	+ 1	Multifamily and Nhskpg.	7,351	6,100	-17
<b>Total</b>	<b>\$21,828</b>	<b>\$19,725</b>	<b>-10</b>	<b>Total</b>	<b>\$32,553</b>	<b>\$29,975</b>	<b>- 8</b>
<b>Nonbuilding Construction</b>	<b>\$11,834</b>	<b>\$11,500</b>	<b>- 3</b>	<b>TOTAL CONSTRUCTION</b>	<b>\$66,215</b>	<b>\$61,200</b>	<b>- 8</b>

Prepared by the Economics Department McGraw-Hill Information Services Company, George A. Christie, vice president and chief economist.

Copyright 1991 McGraw-Hill, Inc. with all rights reserved.

will be the beginning of the next general building cycle.

Total F. W. Dodge housing starts for 1991 are now estimated to slip to 1,050,000 units, a decline of 7 percent from 1990's 1,133,000 volume. The equivalent Commerce Department measures of housing starts are: 1990 at 1,193,000 and 1991 at 1,100,000.

None of the several categories of commercial and industrial building can be expected to survive 1991's recessionary environment without some further weakening, but one stands out as a bit more vulnerable than the rest. Retail building, with its familiar behavioral trait of tracking single-family housing development by roughly one year, is in double trouble. The abrupt collapse of houses in the 1990 credit squeeze is having its delayed effect on contracting for stores and shopping centers in 1991, intensifying the recession's downward pull. The continuing decline of house building through the first half of 1991 is only making matters worse.

Paced by the retreat of retail building, the decline of total commercial and industrial building contract value this year now falls in the range of 10 percent to 15 percent.

Again, as in 1990, publicly funded construction is buffering the continuing weakness of privately financed building. Two categories, in particular, deserve honorable mention for their unwavering support. A gain in highway/bridge contracting in 1991 comes as something of an anomaly. We could expect a fairly tight lid on federal spending for public works. But 2 1/2 percent of the new fuel tax is going to the Department of Transportation and the curious result is that, at a time of maximum budgetary stress, DOT is enjoying a windfall, and highway/bridge contracting is up significantly. Call this "unintentional anti-recessionary fiscal policy" . . . or else call it "business as usual."

Although highway/bridge construction is alive and well in 1991, the same can't be said for the other major public-works category, sewer and waste-treatment facilities. One big difference: their increasing reliance on

*Continued on page 125*



## Specifications Series: Interior Renovation

By Katherine Freeman

Renovation work presents new and often-complex issues to architects and interior designers. Many of these issues cannot be dealt with on construction drawings and, therefore, must be addressed in specifications. The correct interior-renovation specification clearly defines these issues and the roles of the parties involved.

**Asbestos abatement:** Often, renovation of older buildings requires asbestos abatement. This is usually not handled by architects and designers because most liability insurance does not cover their involvement. The owner should hire a contractor specializing in this area under a separate contract.

**Verifying existing conditions:** This is a key step in an interior renovation, as well as a frustrating and time-consuming one. No matter how thorough the preliminary investigation, surprise problems will arise. There will be hidden structural and mechanical conditions that cannot be verified during design. Drawings of the existing space may not be available or may fail to reflect as-built conditions accurately.

**Submittals:** The architect should obtain product data for new work, and certification of fire-resistance and sound-transmission ratings when applicable. Samples will confirm color and finish selections, and help the contractor avoid mistakes. The contractor should submit maintenance instructions for finishes and other items specified, and make certain the client understands them.

**Shop drawings:** These take on a new importance in interior renovations. They must document and verify existing conditions affecting the work, identify work to be removed, repaired, or altered, and the extent of new work. A schedule of items to be cleaned, repaired, and refinished, items to be salvaged and reinstalled, and items to be dismantled or demolished should be included when applicable. Materials and methods can also be documented and monitored. While shop drawings are not tools to refine

design, they can be a means to check design work and to uncover problems before construction so they can be solved quickly and effectively. A detailed description and itemized list of items to include in shop drawings will ensure they are complete. The designer should cover what is required for each item, so that enough production time and effort is included in subcontractors' bids.

**Quality assurance:** Architects should specify manufacturers with experience similar to their project. In matching existing materials, they should specify the original source when possible, obtain field samples for accurate comparison, and define and clarify the expected quality and appearance of the finished product. Mock-ups of new, refinished, or cleaned work set standards for final work.

**Contractor and installer qualifications:** The quality and experience of the contractor and installers are crucial factors. As with manufacturers, the contractor must have experience in renovation similar to the extent and complexity of the project. The designer should see previous projects before final selection. Because renovation is full of surprises, contractors can contribute to unique solutions.

**Preinstallation job meeting:** The architect and contractor should discuss and agree on selective demolition and removal, conservation, and reinstallation of existing materials. Items requiring coordination of trades can be scheduled and sequenced. Inspections of existing work can engage manufacturers' technical representatives and special consultants so that all parties agree on remedial work. Substructures prepared to receive new work can be examined and approved.

**Delivery, storage, and handling:** The contractor should plan the timely and safe delivery, storage, and handling of materials. Specifications should indicate if on-site storage will be available for new materials and for salvaged materials. A photographic or written record of the condition of materials to be reinstalled prior to removal helps fix the responsibility for damage. Indicate if the contractor is responsible for removal, storage, and replacement of existing furniture



*Architects Thompson, Ventulett, Stainback & Associates remodeled two stores and a mall entrance (top) into the Townsquare Foodworks in Rockaway, N.J. Problems included exposing a patchwork roof structure and irregular column grid without major alterations or interruption of mechanical services.*

and equipment, and for coordinating delivery schedules on such final completion items as furniture, equipment, and planting.

**Project and site conditions:** The designer should indicate the contractor's responsibility for maintaining circulation and life-safety standards. The architect outlines procedures and limitations for interruption of building services and defines the contractor's responsibility for damage control and

*Ms. Freeman is an associate with architects Thompson, Ventulett, Stainback & Associates in Atlanta.*



*Part of success is to control the special relationships among architect, contractor, owner—and others.*

repair, and for daily and final clean-up of the site. Lingering debris may become fire hazards if not handled and disposed of properly. The parties must determine responsibility for service-dock and vertical-transportation coordination with the building management or owner. Unique conditions should be addressed and the contractor held responsible for following the manufacturer's instructions for environmental conditions and other installation requirements.

**Sequencing and scheduling:** The contractor's responsibility for coordinating demolition and utilities interruptions with building operations must be indicated, along with specific conditions and procedures for sequencing and scheduling work. Any potential conflicts or aspects of coordination should also be indicated.

**Working in occupied spaces:** If the space is to be partially or fully occupied during the work, the client, design professional, and contractor must coordinate their work to limit disruption. They should establish procedures and limitations when conflict cannot be avoided. Noise, dust, and fumes from paints, carpet adhesives, and wood finishes may be noxious or toxic to occupants and impact plants and landscaping. The contractor should provide adequate ventilation and work after business hours if possible.

**Inspection and verification:** Prior to demolition, the contractor should be required to verify, inspect, and photograph the existing conditions. Requirements should include remedial work such as repair and patching of substructures in appropriate coordinated sections, or these costs may not be included in the bid and may be billed later as an additional service. The designer should call for inspections of prepared substructures by manufacturers' technical representatives and/or such consultants as structural and mechanical engineers prior to construction.

The designers should use specifications as a tool to point out potential conflicts and solve them before they happen. And they must keep their clients informed. ■

## Interior Renovation and Alteration Specification

### PART 1 GENERAL

#### A. Summary:

1. Section includes: Verification of existing conditions. Selective demolition of existing work. Removal, conservation, and reinstallation of existing materials. Coordination of trades involved in alteration and renovation work.
2. Section does not include: Asbestos abatement—in separate contract between owner and contractor.

#### B. Submittals:

1. Product data.
2. Samples—initial selection and verification.
3. Certification: Fire resistance ratings. Sound transmission ratings. Code requirements.
4. Shop drawings.
5. Maintenance instructions.

#### C. Quality assurance:

1. Manufacturer qualifications: five years minimum experience.

2. Installer qualifications: five years experience acceptable to manufacturer.
3. Field samples.
4. Mock-ups.
5. Preinstallation job meeting.

#### D. Delivery, storage, and handling requirements.

#### E. Project/site conditions:

1. Environmental conditions: Climate control conditions within manufacturer's recommendations.
2. Temporary exits and entrances, emergency services, and fire protection.
3. Maintenance of utility services.
4. Environmental protection.
5. Ventilation: for curing materials, paint and carpet adhesive, wood flooring finishes, etc.
6. Protection of existing work.
7. Noise and dust control.

8. Removal and storage of existing furniture and equipment.
9. Vertical transportation and trash removal.
10. Damage control and repair.
11. Occupancy and use of existing facilities.

#### F. Sequencing and scheduling:

1. Demolition work.
2. Coordination of utility service interruptions.
3. Vacating occupied areas.
4. Maintaining circulation.
5. Interference with working conditions, if any.
6. Delivery schedules of furniture, planting, etc.

#### G. Maintenance

- materials** (extra stock): usually 5 percent for standard products, 10 percent for custom.
1. Deliver to owner, labeled, and packaged, with installation instructions.

### PART 2 PRODUCTS

#### A. Materials:

1. New materials: criteria for matching.
2. Reworked materials: cleaned, repaired, and re-finished in place.

3. Salvaged materials: removed, salvaged, and reinstalled.

#### B. Miscellaneous and accessory materials:

1. Products for patching.
2. Cleaning/refinishing products.

### PART 3 EXECUTION

#### A. Examination and verification:

1. Prior to demolition: verification and photography.
2. After demolition: preparation of substrates.
3. Manufacturer and consultant inspections.

#### B. Preparation:

1. Shoring and bracing.
2. Protection of existing furniture, finishes, and equipment not removed.
3. Dust-proof partitions.

#### C. Demolition:

1. Sequence and coordination.
2. Building materials.
3. Mechanical equipment.
4. Electrical equipment.
5. Unanticipated conditions.

#### D. Alteration work:

1. Extent.
2. Damaged surfaces.
3. Salvaged materials: Cleaning, repair, and reinstallation.

4. Transition from existing to new work.

#### E. Disposal of demolished materials:

1. Storage, and removal.

#### F. Cleaning and repair:

1. Installed work.
2. Adjacent work damaged during installation.

#### G. Condition of finished work.



## Low Cost Entry

*Two capable and cost-effective CAD packages let you ease in. Either one runs on \$1,000 worth of equipment.*

Last month, we reviewed Generic CAD 5.0. Autodesk's Autosketch sells for less than \$200. This month we discuss two other CAD low cost entry packages. Either package can run on an IBM XT or compatible with small fixed disk, Hercules monochrome graphics, a mouse, and 640K or less of random-access memory. Add a math co-processor chip, and the equipment can cost as little as \$1,000.

These two packages stem from quite different philosophies. EasyCAD, from Evolution Computing (the same people who developed FastCAD), is a lean and mean 2D program. Its speed makes it terrific for production drafting and for those occasional at-home or on-the-road sessions. It can exchange files with most other CAD packages, using DXF. The DXF file system rarely provides perfect translations. But Evolution's various DXF dialects are quite close to AutoCAD's. They should be. Evolution's founder and chief programmer invented DXF while working for Autodesk, AutoCAD's parent.

DesignCAD 3D has more features, but is much slower and is not as intuitive in its command structure. Aside from 3D capabilities it comes with shading (you can create slide shows), a crude bill-of-materials processor, and even solids modeling. Its distributor also sells DesignCAD 2D (formerly ProDesign II), which is somewhat faster in operation. It can export files to the standard IGES format, and to PostScript (for plotting on laser printers). It can import or export DXF. The native file format for DesignCAD, like DXF, is ASCII text. That makes files quite large.

Unlike EasyCAD, DesignCAD does not support symbol libraries directly. But entities can be grouped into blocks and saved or joined with new drawings. In fact, a library of 2D symbols is available to supplement the product.

Both packages allow customizing of menus, and both have powerful macro languages. These features allow practices to customize this software for use throughout an office, and to reduce training time. You can progress from either package into a more full-featured system, although you may never want to. *By Steven S. Ross*

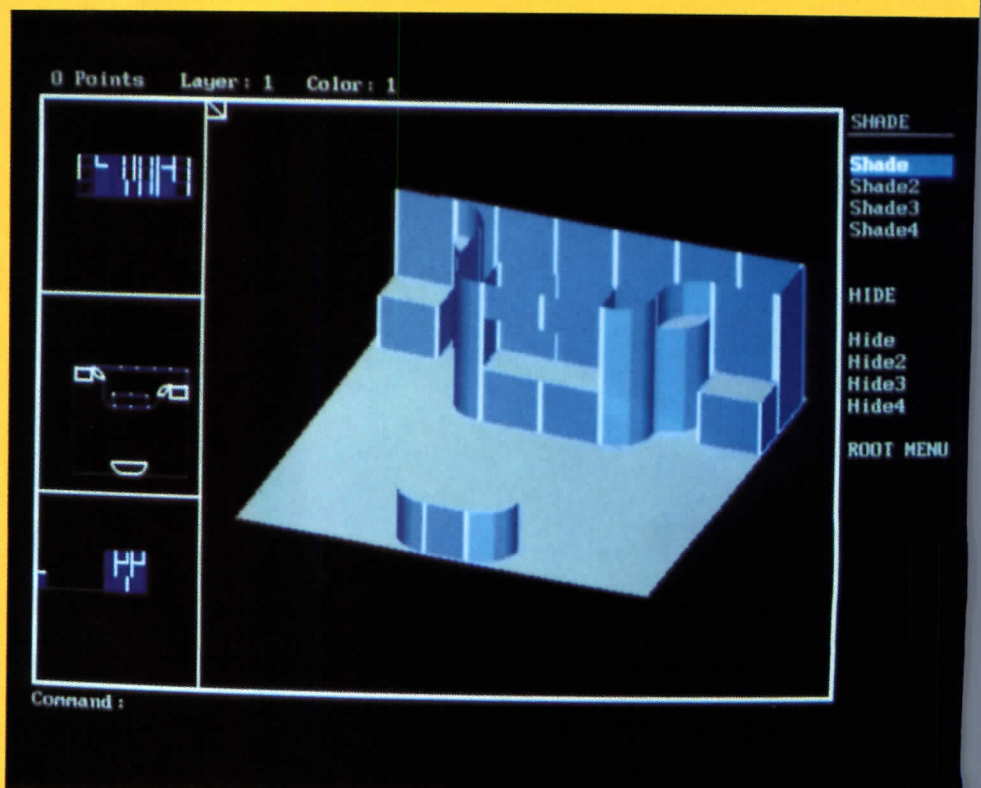



DesignCAD's shading program allows up to eight light sources, but without choice of diffuse or point. Foregrounds can be clipped away. Four views can be displayed at once (1, 2). Each view can be customized

as to viewing angle, but only the big one can be edited and shaded. The bill of materials program (3) lists attributes specified on the drawing. Prices, colors suppliers can be shown, but it is easier to

export the file to a database program and add the data later. Symbols are easily defined in EasyCAD (4).

DesignCAD Materials List Program

Quantity	Item
4	countertop
1	rug
3	stud

Press any key to continue....

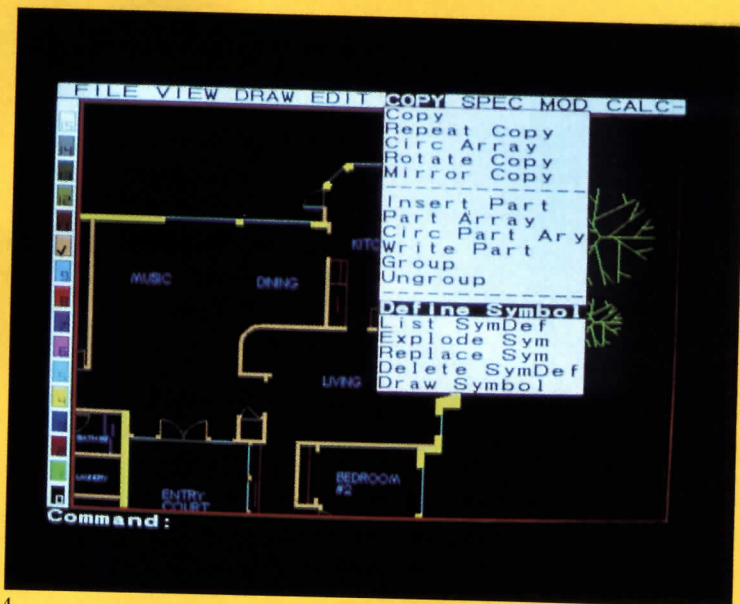

## EasyCAD 2, Version 2.60

**Equipment required:** IBM XT, AT, PS/2 or compatible, DOS 2.10 or higher, 524K of random-access memory (640K or more, as expanded memory, recommended), high-density floppy or (recommended) fixed disk. Math co-processor highly recommended. Mouse or digitizing tablet.

**Vendor:** Evolution Computing, 437 S. 48th St., Suite 106, Tempe, AZ 85281. Phone 602-77-8633, 800-874-4028. \$169.95. Thirty-day money-back guarantee.

**Manuals:** One well-written 500-page paperback with tutorials, installation instructions, and reference guide.

**Ease-of-use:** Good. There are large pull-down menus, associative dimensions (change dimensioned object and the dimension line changes as well), and all the basic drawing tools. Walls are drawn as hollow or cross-hatched "wide lines." Sixty-four cross-hatch patterns are supplied; they expand and contract as scale changes. Easy file export to

FastCAD and FastCAD 3D. (EasyCAD is essentially an older version of FastCAD.) Good compatibility (via DXF) with AutoCAD. Above all, this package is really fast, even on an old computer.

**Error-trapping:** Good. Most commands can be "undone."

Circle number 315

## DesignCAD 3D, Version 3.0

**Equipment required:** IBM XT, AT, PS/2 or compatible, 640K of random-access memory, fixed disk. Math coprocessor, mouse or digitizer, and more RAM (as expanded memory) strongly recommended. Works with many printers and plotters, but not with PostScript.

**Vendor:** American Small Business Computers, Inc., 327 South Mill St., Pryor, OK 74361. Phone 918-825-4844. \$399. The 2D version retails for \$299 (a new version, at the same price, was due in April). DesignSYM library of 5,000 2D symbols, \$179. DesignCAD Macintosh, 3D, \$699.

**Manuals:** Three paperbacks: one for installation instructions and a tutorial, a reference, and a guide to the macro language.

**Ease-of-use:** Good. Three-dimensional objects are most easily built up by sweeping a polyline in space, or by combining primitive 3D shapes such as blocks. As you might expect with a 3D package, it runs extremely slowly on an old XT. Hidden-line removal is slower than for most 3D packages; shading speed is about average. The installation program insists on using drive A. If you must, you can reassign drives using the DOS assign command.

**Error-trapping:** Good. Most commands can be undone. The biggest problems come from features that can be toggled off to improve speed, such as associative dimensioning. You have to discipline yourself to work with specific features enabled or disabled at all times; you can get confused if you change in the same drawing. Zooms undo shades and hidden-line removals. If you shade a view, be sure to save it before doing further manipulations.

Circle number 316



# Recirculating the Past

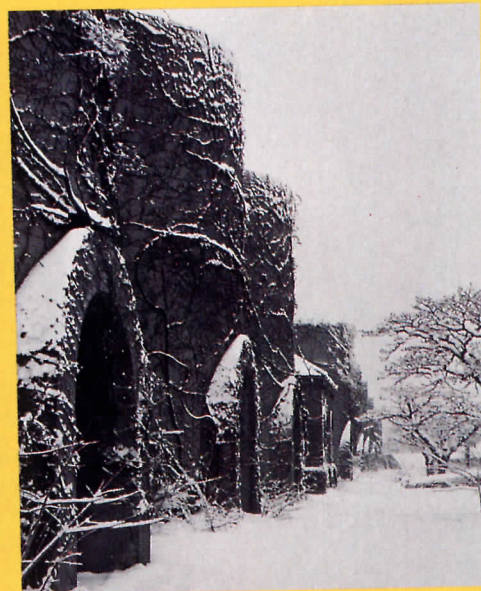

*Anice Hoachlander photos*

The McMillan Filtration Plant's two neat rows of squat masonry silos and low-slung brick regulator houses, built in 1902-1905, seem sadly incongruous today, bracketed by two major Washington traffic arteries and a sprawling chemical plant on an adjacent parcel (background of photo top left). Old-fashioned as these structures now appear, they were part of the city's slow sand water filtration system until 1985, when the newly completed chemical plant's computerized system rendered the sand-storage silos and 29 subterranean filter beds obsolete.

The old plant was part of an ambitious turn-of-the-century scheme spearheaded by U.S. Senator James McMillan of Michigan, who envisioned the entire 92-acre site and its filter beds, silos, reservoirs, and pumping facilities as part of the capital's public park system. Hydraulic engineer Alan Hazen of New York City was hired by the Army Corps of Engineers to help combat frequent outbreaks of typhoid attributed to a contaminated water supply. Hazen designed the complex routing that brought water from the Potomac River 14 miles away into one



*In 1905, the McMillan Filtration Plant began operation of its slow sand filtration system to provide clean water for Washington, D. C. Although computer technology has made the*

*system obsolete, preservation groups argue that the plant's eerily beautiful masonry structures are well worth saving.*

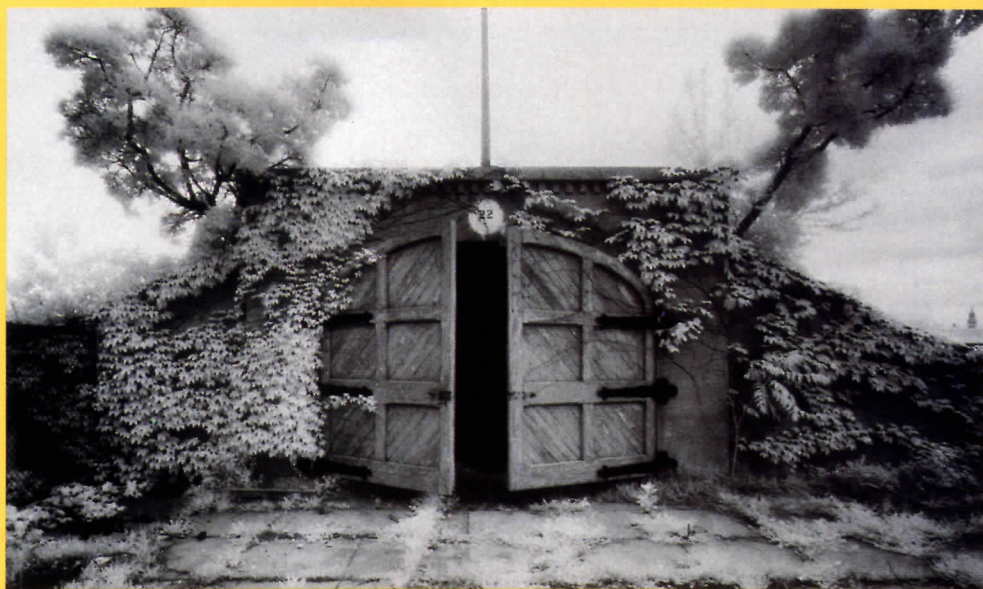

re concrete compartments (bottom right) partially filled with sand. Filtered clean water was funneled to an underground reservoir, where it would remain until the pumping station distributed it throughout the city. Soon after Hazen's silos and regular houses were put to use, Frederick Law Olmsted, Jr., was hired to make the surrounding area more inviting to the public. Instead planted allées of mulberry trees along pathways between the silos and regular houses, transforming the blanket of

atop the filter beds into a picturesque field. The complex was used as a public park until World War II, when local officials fenced in the filter beds, fearful that the Germans would try to poison the capital's water supply. Nearly half a century later, McMillan's plant is again in danger, this time from developers who plan to purchase the site and raze the structures. Local preservation groups, however, hope to secure landmark status for the plant in a hearing scheduled for this spring, thereby ensuring a future for McMillan's and Olmsted's vision. *K. D. S.*



## Rediscovering Eliel Saarinen's Early Years

Renderings from 1903 by Saarinen (below left) and his partner Gesellius (below right) show the importance of drawing and color to their design process.

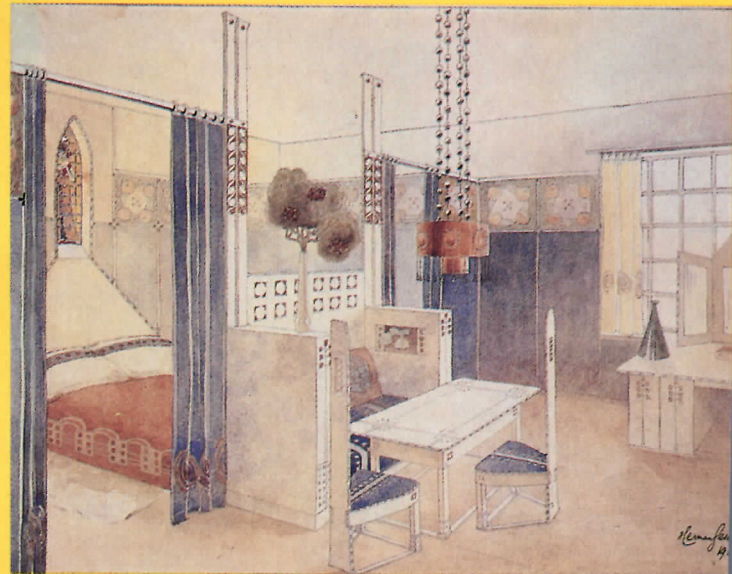
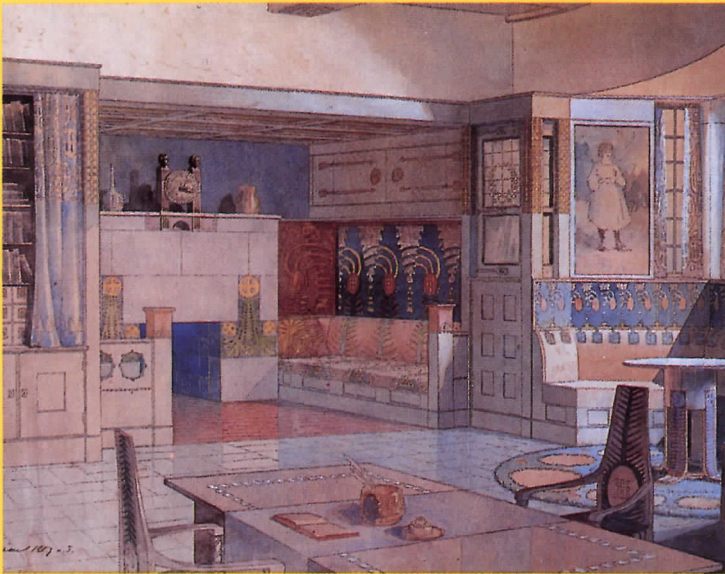

**Eliel Saarinen: Projects 1896–1923**, by Marika Hausen, Kirmo Mikkola, Anna-Lisa Amberg, and Tytti Valto. Cambridge: MIT Press, 1990, 355 pages, \$125.

Reviewed by Ralph E. Johnson

This beautifully produced volume is an important addition to the literature on Eliel Saarinen prior to his move to the United States, a period known to Americans mostly for his Helsinki Railway Station and his home and studio in Hvittrask. The book expands our knowledge of Saarinen by comprehensively recording and analyzing his career, from his partnership with Gesellius and Lindgren in 1896 to his departure in 1923 in the wake of his influential second-place entry for the Chicago Tribune Tower competition.

Many of the issues that concerned Saarinen at the turn of the century still resonate in the profession today. As then, architecture is split between those who advocate continuity with classical and vernacular forms and those who suggest that our era demands a break with the forms of the past. In focusing on Saarinen's early career, this book lets us examine how he balanced the rational with the romantic, culminating with his scheme for the Chicago Tribune Tower.

The book features two essays—one on Saari-

nen's architecture and the other on his town-planning projects—as well as a complete catalog of his work for this period. Reflecting the comprehensive nature of the book, the catalog includes Saarinen's arts and crafts work and his industrial design projects, in addition to architecture and planning. The quality of the reproductions and of the book itself is an appropriate testimonial to Saarinen and his work.

The essay by Marika Hausen includes a presentation of 19 major works. It follows Saarinen's career from his early use of natural materials, such as stone and wood, to his later projects, in which he successfully integrated the more rationally based concerns of functional expression with traditional typologies. Hausen categorizes Saarinen's work into two periods: 1896-1905, during which he practiced with his classmates Gesellius and Lindgren, and 1905-1923, during which he briefly worked with Gesellius before venturing out on his own. The design of the Helsinki Railway Station serves as a chronological as well as a stylistic bridge between the two periods. Hausen also notes how Saarinen's designs for the Helsinki and Viipuri stations combine architectural and town-planning concerns, enabling them to function both as freestanding monumental objects and as organizing elements in the urban fabric. Unfortunately, this interweaving of architecture and city planning was sorely

lacking in most urban-renewal schemes of the mid-20th century and is only now reappearing in the work and writings of Aldo Rossi and others.

By including Saarinen's sketches and renderings, the book allows us to appreciate why the nine-year-old Alvar Aalto was so moved when he first saw a Saarinen drawing reproduced in a popular Finnish magazine at the turn of the century. Both the quality and sheer volume of sketches, many published in color, show Saarinen's unique talent as an artist, as well as the importance of drawing to his design process.

The other major essay, by Kirmo Mikkola, places Saarinen's town-planning schemes of 1910-1918 within the framework of modern planning theory. Mikkola notes how the geometry of many of Saarinen's schemes evolved from a combination of the romantic and picturesque notions of Camillo Sitte (whom Saarinen admired) and the Classical approaches of Haussmann in Paris and Cerda in Barcelona. Having speculated in real estate himself, Saarinen was familiar with the economic realities of town planning and was able to balance social and artistic concerns with the financial elements of the modern city.

Ralph E. Johnson is a principal with Perkins & Will in Chicago.



*Ledoux's designs for toll-gates or barrières in Paris (below) exhibited his eccentric approach to reinterpreting and distorting Classical forms.*

**Claude-Nicolas Ledoux**, by Anthony Vidler. Cambridge: MIT Press, 477 pages, \$50.

Reviewed by Jonathan Hale

Anthony Vidler's book on Ledoux is likely to be *the* book on the subject for years to come, so we are lucky it is so well-written. Vidler, who teaches at Princeton, places Ledoux in context of pre- and post-Revolutionary France and in relation to our own time. Finding Ledoux's place in architecture is no mean task, given history's contradictory attitude to him. Ledoux has been seen variously as a forerunner of Modernism, Post-modernism, Neoclassicism, even Surrealism.

Ledoux himself was full of contradictions. No doubt this is one of his attractions to our age.) He started out a country bumpkin, but soon became a court favorite and eventually a social and architectural visionary. Over the years, his buildings increasingly embodied an evolutionary simplicity and daring. But when revolution came, Ledoux discovered he had no place in the new order.

Ledoux was a showman, which is not to say he was superficial. Some of his works appear to be deliberately strange. A Ledoux building, for example, might combine mundane use with a rough gigantism that was new and, to some of his contemporaries, repellent. Amidst the excitement of his work there is often a curious coldness, a weird icy grandeur to his designs.

Among Ledoux's most contradictory works were the toll-gates of Paris. They were hated from the moment they were built because of their function and their strange appearance. But to us they are striking. In these *barrières* Ledoux was artistically audacious, but politically conservative. These little monuments had giant half-domes carved out of watchman's houses, or enormous keystones on tiny sentry booths. They had odd towers and great freestanding columns. The designs go beyond eccentricity; they freely distort the common equipment of classical design to make vivid compositions.

Examples of Ledoux's influence on later architecture and on our times are conspicuous

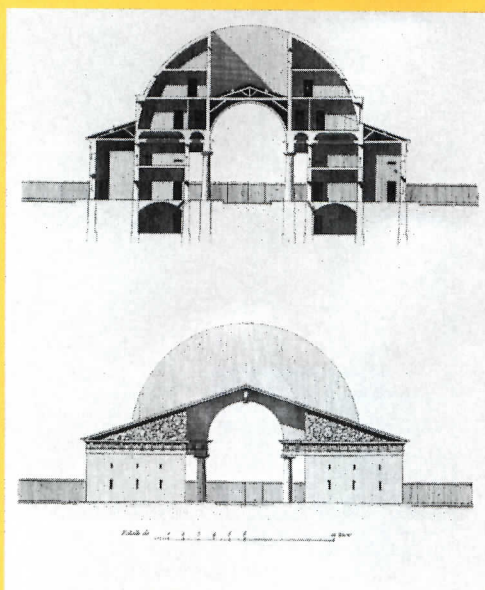

by their absence from the book. Vidler seems to be saying that, although Ledoux rings a lot of bells for us, he is not our direct architectural ancestor. Although often compared with his contemporary, Boullée, whose most famous works existed only on paper, Ledoux was a builder. But after the Revolution, Ledoux failed again and again to get commissions, and his designs took on a dreamlike quality. In these later years Ledoux became more the visionary we think of today. The buildings became stripped-down. They veered away from the comfortable clichés of Classicism and toward a severe, and at times strange, new idiom, which resonates with our age. Even so, Ledoux's work was not so much a precursor to Modernism as it was an expression of the radical shifts happening in his own day.

The book is generously illustrated, mostly with engravings made in Ledoux's time. While the engravings are superb, more and better photographs would have been helpful. The book would also have benefited from a pictorial chronology, thumbnail sketches, and brief descriptions of each project. But this is a book to be read slowly, taking in the images of a time surprising not in its similarity to our own but in its remoteness from it.

Jonathan Hale is an architect and former RECORD editor.

**Berlin: The Politics of Order 1737-1989**, by Alan Balfour. New York: Rizzoli, 1990, 270 pages, \$39.95

Reviewed by Gerald Moorhead

Berlin. The city is heroic, almost holy to the Cold-War generation as a symbol of defiance in the face of totalitarianism. While Berlin now anticipates its renaissance as the capital of a unified Germany, Alan Balfour's book serves as a provocative guide to its lost past. By restoring the memory of what once was, this perceptive book may help set a direction for the future rebuilding of its devastated quarters.

The wanton destruction of Berlin by the Russian army in 1945, says Balfour, eliminated "not only memories but ancient and comforting symbols whose accumulation in the texture of a city had given meaning to life." The author adds that the "loss of the past means the loss of the future."

Using a small area of Berlin—the streets and squares around Leipziger Platz—Balfour has structured a social, political, and architectural history of the men and events that directed the city's physical development for 250 years. This is a history that, by extension, analyzes the whole city and nation.

Shaped by economics, politics, and design theory, the buildings that grew around Leipziger Platz are both detached witnesses to history and active participants. Using a scrapbooklike assemblage of period photos, and texts, Balfour documents the succession of architectural monuments to occupy the area—including gates designed by Karl Friedrich Schinkel, Bismarck's Chancellery (and Albert Speer's extension of it), and the National Gallery by Mies van der Rohe.

In Balfour's analysis, all of these structures were tools of political ideologies. But he sees a change for the new Berlin. "After 250 years of speculation, the desire to use architecture to control the moral order of the future has faded."

After two and a half centuries, Leipziger Platz is again vacant, awaiting a new history to be built upon it.



## Briefly noted

### **The Art of the Architectural Model,**

by Akiko Busch. New York: Design Press, 1991, 128 pages, \$39.95.

As well-crafted as many of the miniatures it examines, this book combines a practical approach with an esthetic appreciation of its subject. While it covers technical issues such as materials, illumination, and photography, the book also shows how models can help place buildings in specific settings and thus put architecture in context.

### **New Construction for Older Buildings: A Design Sourcebook for Architects and Preservationists,**

by Peter H. Smeallie and Peter H. Smith. New York: Wiley, 1990, 211 pages, \$54.95.

A survey of projects mostly from the 1980s that involve adding onto or building within older structures, as well as new projects set in the context of older neighbors. The book also serves as a guide to adaptive-use projects around the country.

### **Building Design: Improving Commercial Spaces,**

by Elyse Umlauf and Phil Schreiner. Glen Cove, N. Y.: Library of Applied Design, 1990, 256 pages, \$60.

Well-illustrated with color photographs throughout, this book profiles 42 successful renovation projects in the United States. Chapters cover the renovation of office structures, retail complexes, and institutional buildings, as well as adaptive-use projects. Most of the projects covered, including the transformation of Washington, D. C.'s Union Station into a mixed-use complex and the conversion of North Pier in Chicago into a mall, are of recent vintage.

### **Understanding Infrastructure: A Guide for Architects and Planners,**

by George Rainer. New York: Wiley, 1990, 278 pages, \$39.95.

As reports on our nation's deteriorating infrastructure grow more alarming, this hands-on primer on water supply, sewers, streets, bridges, parks, rail transit, and telecommunications systems brings up to speed architects and planners, two groups not notably conversant with infrastructure's framework and its design implications and opportunities. Ten experts on various aspects of infrastructure design contributed chapters. ■



*Don't go any further. The city has just given this structure landmark status.*



The deliberate variety of building types found on the following pages contrasts sharply with our recent single-topic issues on houses and preservation. Which is as it should be: while RECORD prepares for its 100th anniversary in July, we continue to examine the world of architecture both in depth and in breadth—the former through Building Types Studies and special-focus issues, and the latter through portfolios of projects that may have little in common except the architects' dedication to good design.

This month, that commitment finds physical form in featured buildings that stretch from the Gold Coast of Australia to the Gulf Coast of Florida. Although Arata Isozaki's poetic essay in stone for Bond University (cover and pages 58-65) and Roger Ferri's variation on a Florida wood-frame vernacular theme at Seaside (pages 74-77) are at opposite ends of the earth, they share a profound awareness of architecture's role as placemaker. The architects of two large infill projects in major American metropolises improved existing urban contexts—Don Hisaka with an unusually refined response to Washington's building-height limit (page 66-73), and Arrowstreet with a retail center that blends easily with its semi-industrial setting in Cambridge, Massachusetts (pages 96-103). A museum in Indianapolis with subtle Native American imagery (pages 104-109), a pair of innovative "lab lofts" at Penn and Dartmouth (pages 78-87), and a skillfully restored landmark of Frank Lloyd Wright's early years (pages 88-95) complete the mix. *P. M. S.*



# Far East, Down Under





*Arata Isozaki's Library  
Administration Building is the  
centerpiece of Bond University.*

*Library Administration  
Building, Bond University  
Queensland, Australia  
Arata Isozaki & Associates,  
Architect*





**B**ond University, situated on Queensland's Gold Coast, is Australia's first privately funded university, largely underwritten by the now financially embattled entrepreneur Alan Bond. The guiding master plan, prepared for a vacant 247-acre site on the eastern seaboard of Australia, is the work of Melbourne architect Daryl Jackson, who won the commission by competition in November 1986. The scheme called for a total academic environment for 10,000 students that could be built in three stages over 10 years, complete with service infrastructure, dormitories, classrooms, offices, and landscaping.

Jackson proposed a hybrid of European architectural forms from all periods. As a place for students both to live and work, the buildings attempt to personify both "village" and "urban" themes, which, one could argue, present an inherent contradiction. The village narrative was drawn from the tradition of medieval universities—self-sufficient, independently styled communities adjacent to a town. The urban narrative, which sees Western-type universities as one of several aspects of city life, is reflected in the two seemingly endless axes that crisscross the site (plan right), with the academic quadrangle only one star in an ordered metropolitan galaxy of services.

Alan Bond's corporate partner in the venture was Japanese construction giant EIE, who nominated Arata Isozaki as designer of one building. Isozaki, who felt an affinity with Jackson's plan, chose the centerpiece, a bridge structure spanning the principal ceremonial axis (overleaf). Of the two main pedestrian axes across the site, the path under Isozaki's building is the shorter, more consciously compressed sequence. Using a natural change in grade, it connects a symmetrical forecourt complete with tapered colonnades to a lower plaza with a circular water basin (pages 62-63). Here, Isozaki deftly plays a Renaissance game between the formal and the picturesque. In the middle of this self-contained arcadia, Isozaki's 160,000-square-foot building acts as a triple gateway, not only between town and countryside, but also between its own two principal wings.

Contained in the twin arms of the U-shaped building are the phase-one-stage humanities department and library (site plan shows future expansion). In a touch of overt orderliness, the two functions are joined by shared administrative offices housed in a 96-foot-long bridge of poured-in-place reinforced stone-faced concrete, with Isozaki's crowning "keystone" office suite providing the vice-chancellor (as the president is known) with commanding views of the entire university domain.

The strength of Isozaki's building is its commitment to architecture as a compilation of recognizable geometric forms. Conical roofs mark entrances; expressed lintels, carefully proportioned for their span, delineate wall openings. The whole ensemble is unified, however, by the distinctly regional flavor of the lavender-streaked locally hewn sandstone, wet-jointed and pinned to the concrete substructure.

In Australia, the establishment of a university typically requires a healthy budget provided by the Ministry of Education. With no official funds available in Queensland, university officials managed to secure corporate sponsorship at a previously unknown scale. Jackson and Isozaki have given powerful form to this institutional precedent. *Graham Jahn*

*Graham Jahn is a Sydney-based architect and critic.*

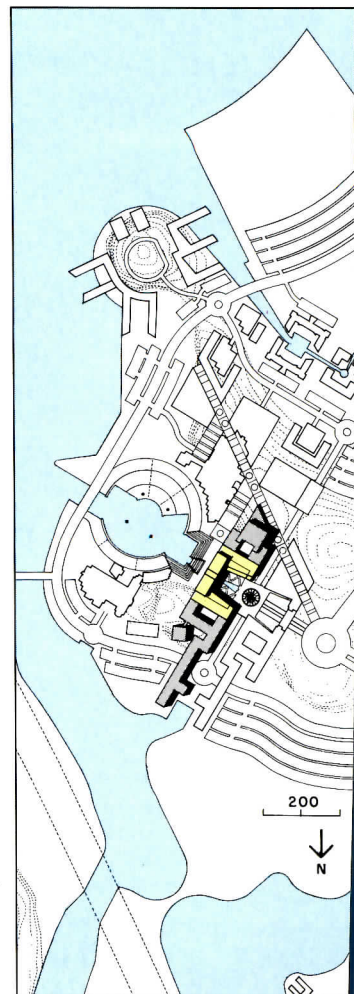

*The site slopes to either side of the main axis that joins the entry roundabout with a knoll along the water. Another axis leads from the entry to the trapezoidal forecourt to Isozaki's building (future expansion is shown above).*

1. Entrance
2. Student administration
3. Central computer
4. Mainframe computer
5. Book storage
6. University general store
7. Office
8. Colonnade
9. Humanities entrance
10. Library entrance
11. Humanities gallery
12. Lecture room
13. Language laboratories
14. Library foyer
15. Reading room
16. Humanities office
17. Administration office
18. Vice-chancellor's office



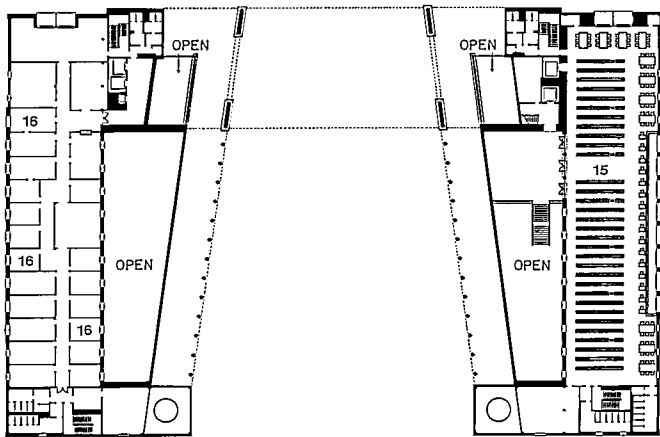

LEVEL THREE

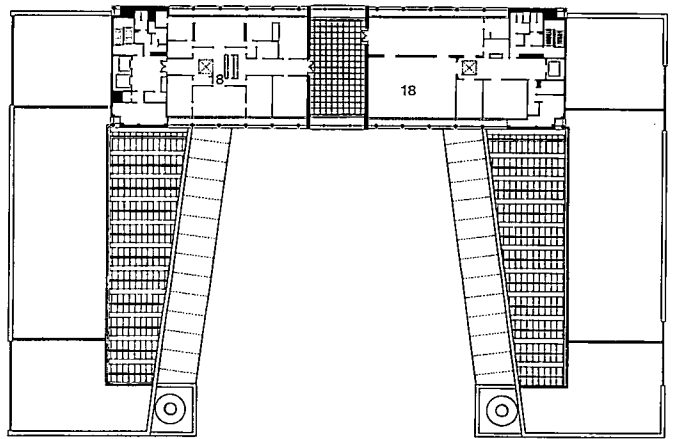

LEVEL SIX

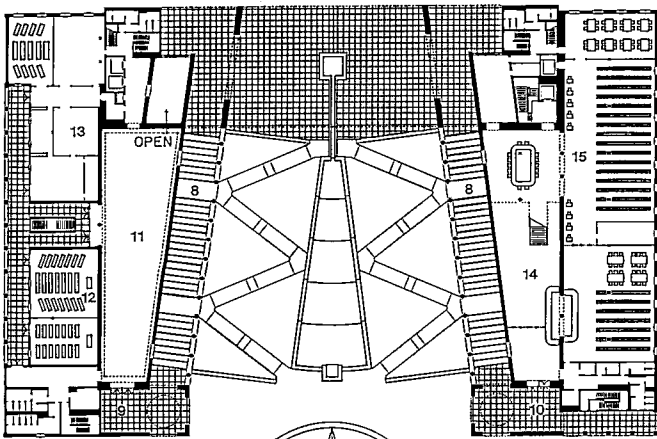

LEVEL TWO

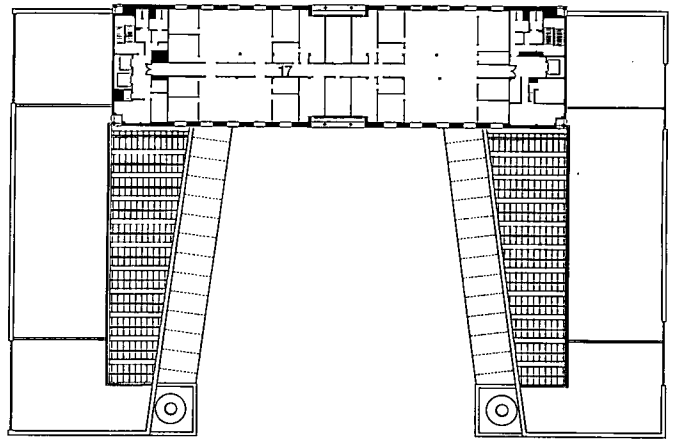

LEVEL FIVE

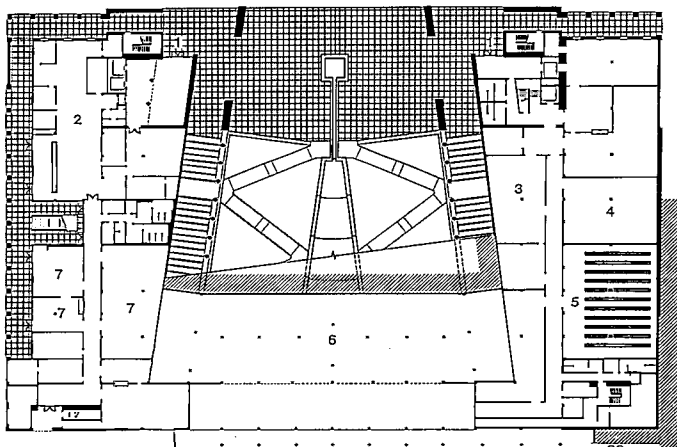

LEVEL ONE

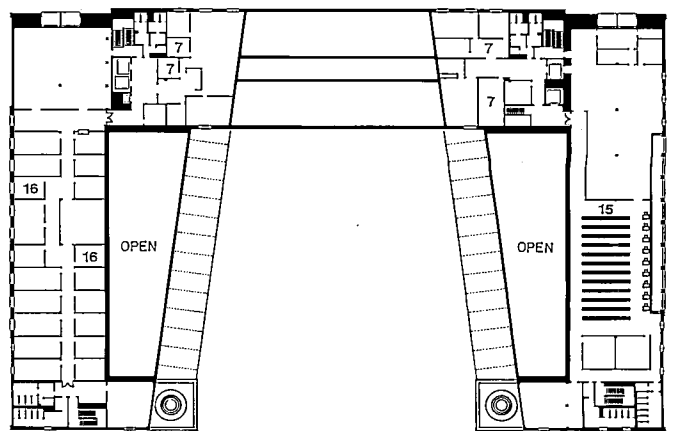

LEVEL FOUR







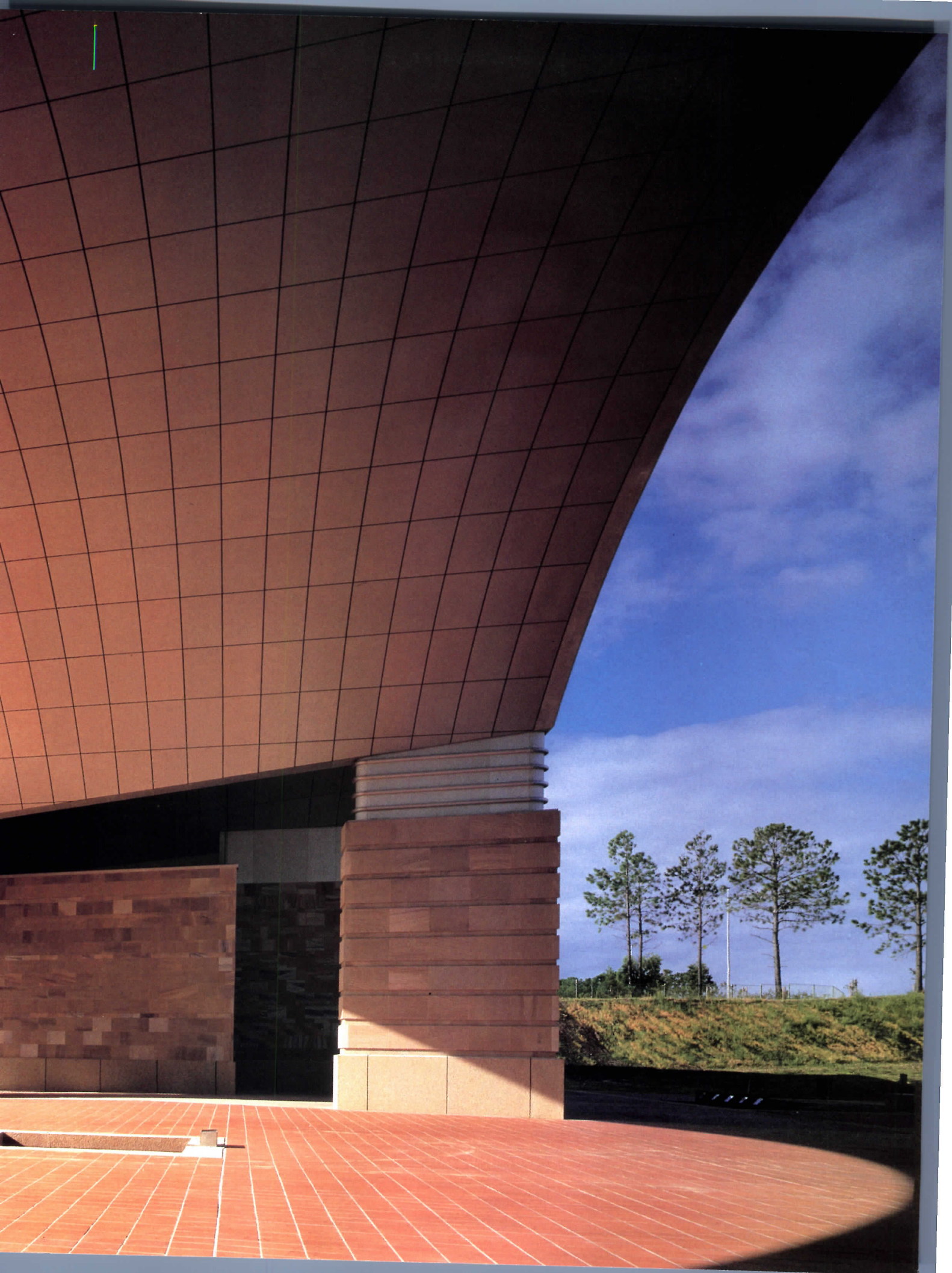



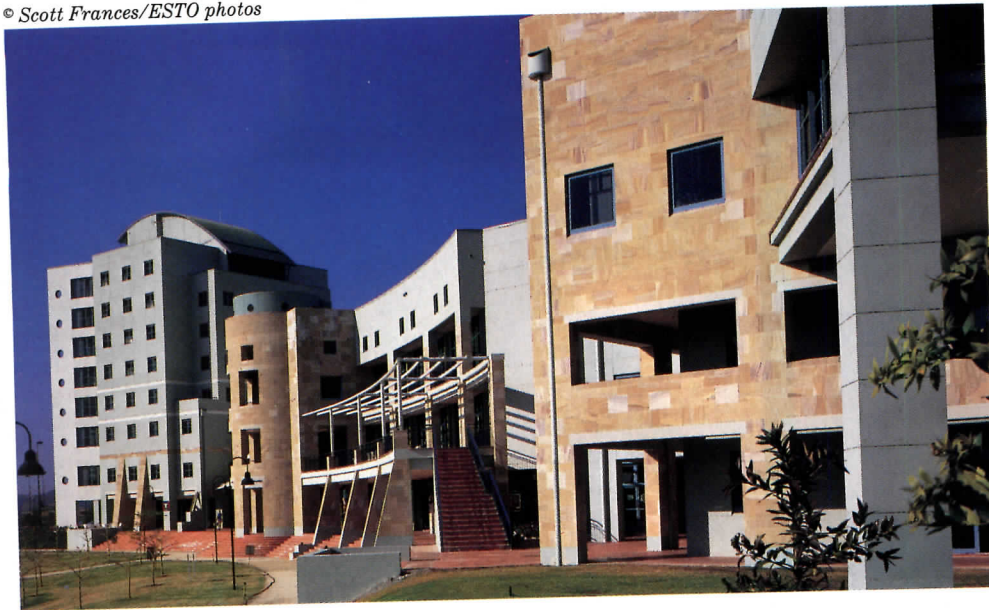

As buildings move away from the administrative center of the campus, they become less formal in composition in a conscious attempt to break with the geometry of Daryl Jackson's master plan. The curved perimeter of the student center (top and middle left) faces the lake. Entry towers by Jackson (bottom) mark the path to the forecourt of Isozaki's building.

**Credits**

*Library Administration Building*

*Bond University  
Queensland, Australia*

**Owner:** *Bond University*

**Architect:** *Arata Isozaki & Associates—Arata Isozaki, principal-in-charge; Hiroshi Aoki, Kenji Sato, Sarah Wong, and Kazutoshi Imanaga, project team*

**Associate Architect:** *The Heather Thiedeke Group*

**Engineers:** *McWilliam and Partners (structural); Lincoln Scott Australia (mechanical/electrical); Weathered Howe and Associates (hydraulic)*

**Consultants:** *Norman Desney and Young (communication); Rider Hunt Gold Coast (quantity surveyor)*

**General Contractor:** *Thiess Watkins White*

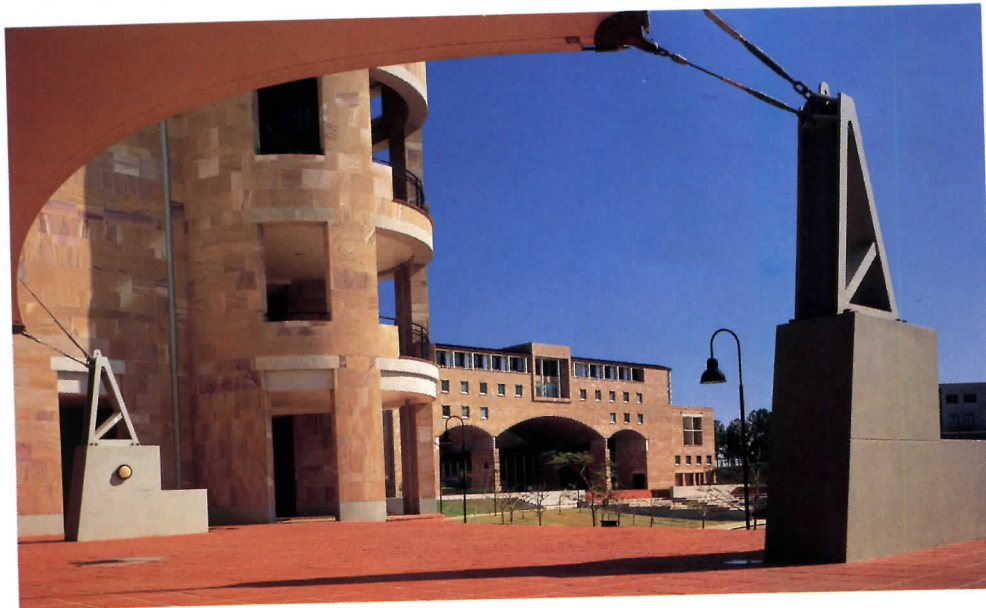



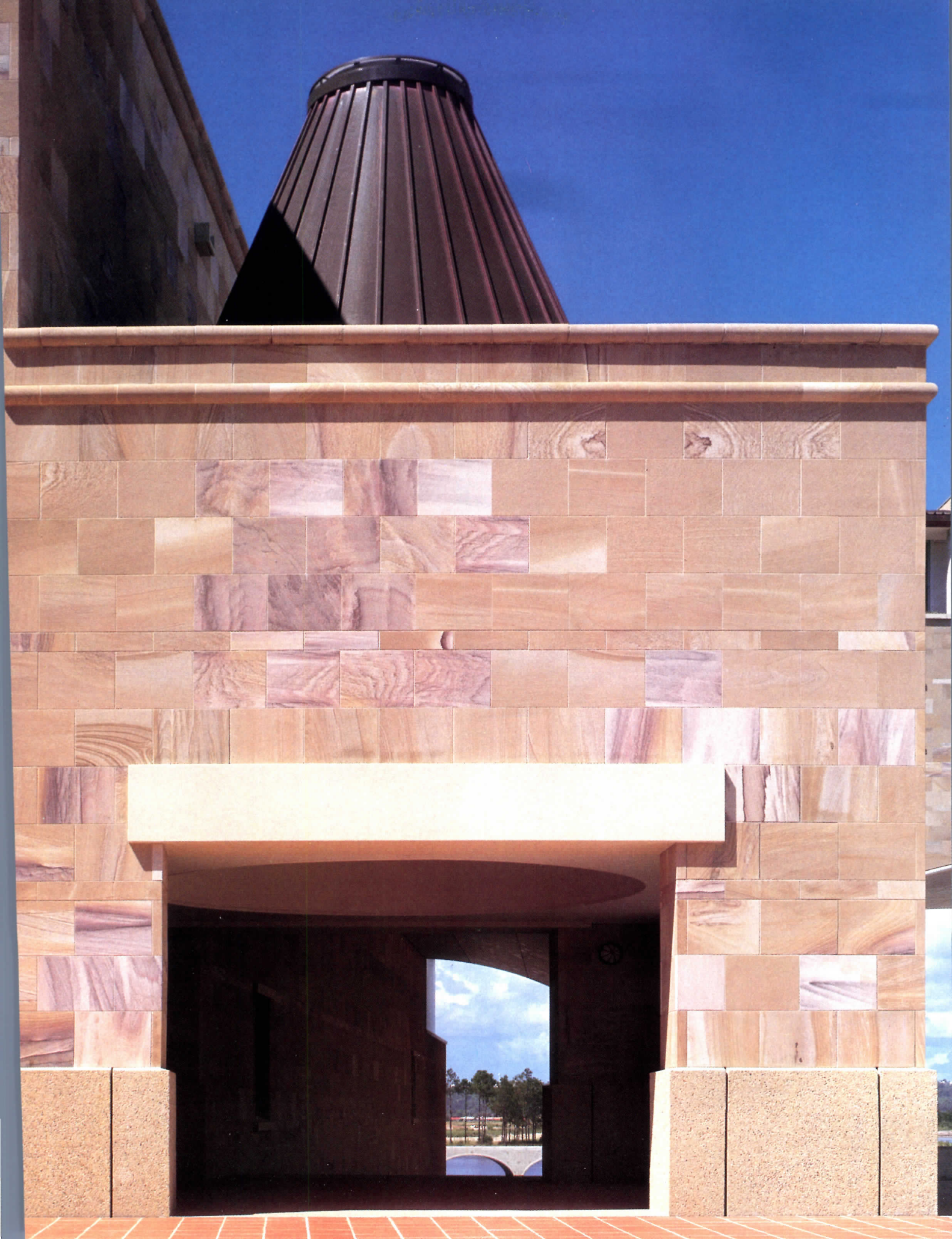



# New Grid on the Block

1150 18th Street, N. W.  
Washington, D. C.  
Hisaka & Associates, Architect





With its facade dimensions preordained by a 75-foot street frontage and 10-story height limit (plus English basement and two floors of underground parking), 1150 18th Street turns its relatively small size (187,000 square feet with 17,000-square-foot floor plates) to advantage with a lighthearted curtain wall (opposite) whose energy would overpower at larger scale. Similarly, the long angled approach from the street entrance to the midblock atrium/lobby becomes an eventful progress through a lively retail arcade.

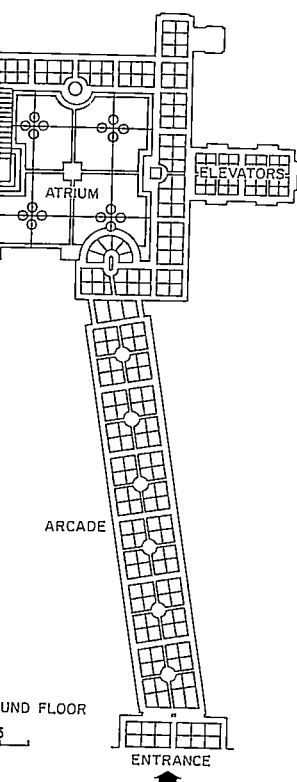

On sunny days the newly opened office building at 1150 18th Street between L and M streets announces itself from several blocks away as a glinting white sliver at the heart of Washington, D. C.'s prime commercial district. Closer in, the sliver becomes an effervescent construction of clear glass and glossy painted metal made the more refreshing by contrast with its slick but elephantine neighbors.

In a rave review *Washington Post* critic Benjamin Forgey likened the building to "an explanation point that fits somehow into the middle of a ponderous sentence." Architect Don Hisaka himself admits to a studied retort to what he terms the "heaviness" of much present-day commercial architecture, which in Washington is weighted further by the city's height limit. Reinforcing the shift from the surrounding glut of granite and mirror glass, the facade gains added bravura from the almost Baroque energy Hisaka has released by using the concrete structure's pier-and-infill order as a foil for a crisply articulated metal lattice.

Built flush to the sidewalk at the base and flanked by corner towers, the building front steps back three feet at the fourth floor, rising above a transitional third-floor balcony that crosses the base as a "cornice" to visually transfer its weight to the ground. Countering the towers' verticality, the grid of the curtain wall is strongly horizontal. A deftly detailed assemblage of off-the-shelf parts, the facade gains much of its texture from simple 4 1/2- by 2 1/2-inch angles deployed as outriggers on horizontal mullions of standard 2-inch sash. In addition, the preformed insulated panels used for spandrels and horizontal rails at the towers, as well as for column covers, take the shape of channels whose shallow flanges add disproportionately to the depth of the facade and the play of light and shadow across it. Garnishes include a spiky open parapet that erupts into turrets at the towers, a perforated-metal medallion, and a clutch of flagpoles which will fly colorful sculpted metal banners.

For all its bravura, the project is more than facadesmanship. Ironically, its lean vitality owes much to an "impossible" site. Although it met the top three criteria within the developer's canon—location, location, location—the parcel fell short by other measures. Its primary asset, the frontage on 18th Street, was a pinched 75 feet that bored well into the block before widening to an L-shape formed by space leftover from surrounding buildings and bound by alleys. The footprint encompassed only 17,000 square feet overall in a market where the usual tenant floor offers upwards of 30,000.

Nonetheless, the building plan—an afterthought in many core-and-shell spec buildings—is both inventive and highly marketable. The key was to place the now-*de rigueur* atrium not at the entrance but at the L's inner angle, approached via a retail arcade. The atrium is tiny: less than 900 square feet. But it is expanded by a wall of windows on the south, which are combined with generous punched openings in the alley-facing walls to flood the midblock building with light. To temper its height, the atrium gives way at the sixth and eighth floors to sky lobbies that create self-contained two- and three-story office suites—both quickly claimed by large tenants. On lower floors the open corridors edging the central space make for flexibility in layouts and leasing by allowing several entries to each floor.

In the atrium itself witty flourishes—the flash of mirror-bright stainless steel against monochrome metal and dry wall, tiers of little projecting balconies (one set wraps a column), lighting fixtures that decorate as well as illuminate, the play of grid on grid—convey an animation that affirms the promise of the exterior. *Margaret Gaskie*





1150

PARK  
N.Y.C.



Complementing the playful turrets and spiked parapet at the crown (top right), the towers carry their emphatic curtain-wall grid to sidewalk level (opposite), where they frame a base strongly but simply defined by opening up the tight framework at the second and third floors. Flag staffs, for which the owner has commissioned bright blue-green banners sculpted of perforated metal, signal the building entrance (bottom right). Inside, artful lighting and contrasting materials (polished metal and rough granite against ordinary dry wall) enrich the arcade that angles toward the atrium. Glass cases en route will display a local art gallery's wares. The L-shaped typical floor facilitates subdivision with three entry doors per floor and adds flexibility with post-tensioned concrete beams that allowed larger-than-usual bays (34 by 28 feet) within the usual ceiling height.

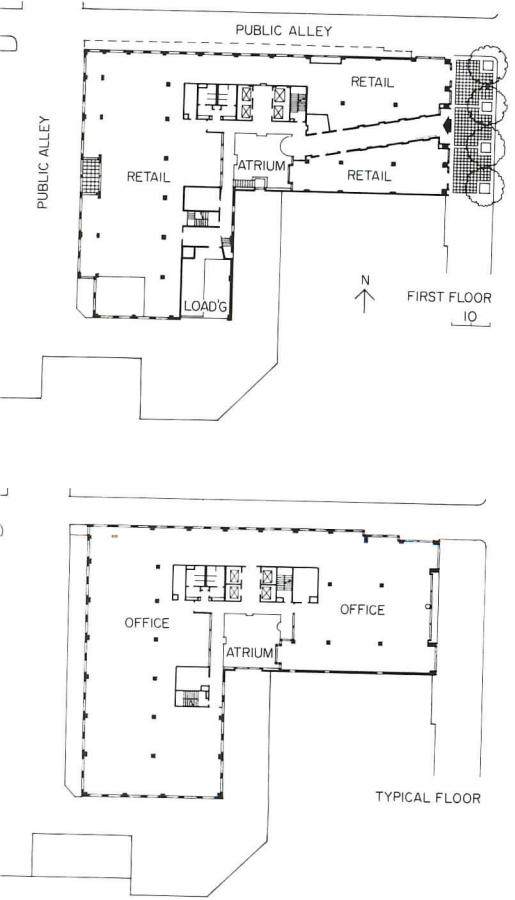
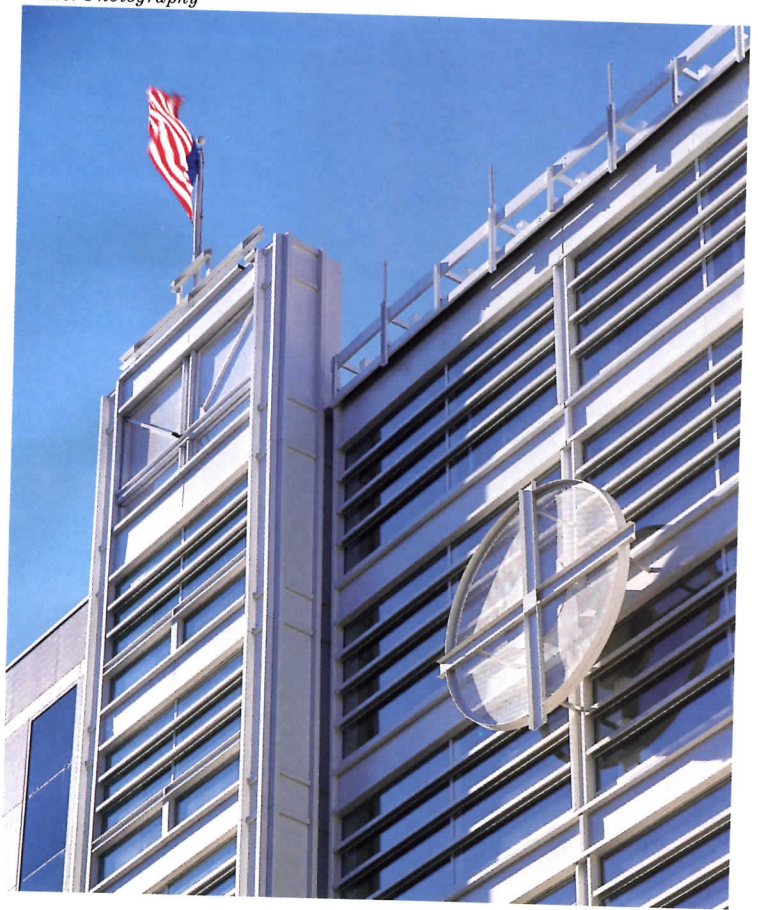





Although the structure of 1150 18th Street is concrete, and pre-cast cladding with big 6- by 6-foot punched windows is used on the three sides that face alleys, Hisaka wanted a livelier, "huskier," he says—but budget-minded—curtain wall for the building's street face. He achieved it with what colleague John McDonald calls "standard sticks" built up into a lattice. The basic unit, standard 2-inch aluminum sash, is augmented at the horizontal mullions with 4 1/2- by 2 1/2-inch angles used as outriggers to beef up the section and emphasize shadow lines along the clear-glass windows. Larger members such as spandrels and column covers are also factory-insulated breakformed aluminum panels pre-painted gleaming white. Channel-like sections again contribute maximum depth and texture with minimum means. In addition to the 3-foot setback, the towers are distinguished from the center front by slight changes in the grid's detailing. In the center, fin tubes are incorporated with the sill at the floor; at the towers, they are located behind an added horizontal rail.

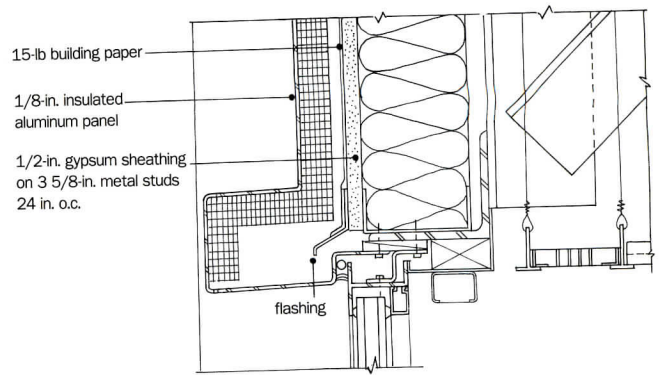

A. TOWER DETAIL AT HEAD

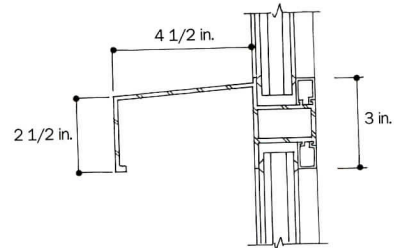

B. TYPICAL DETAIL AT HORIZONTAL MULLION

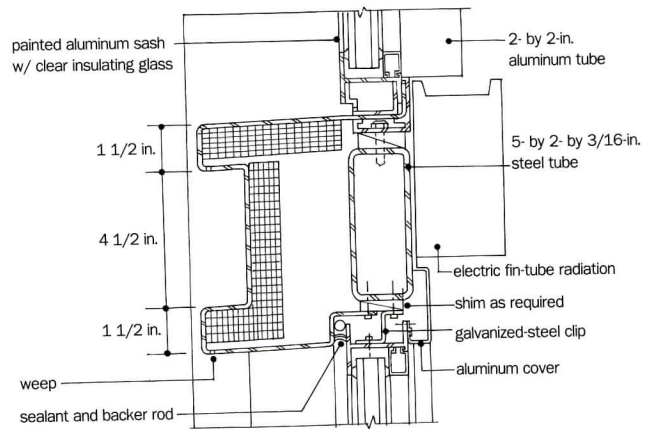

C. TOWER DETAIL AT HORIZONTAL RAIL

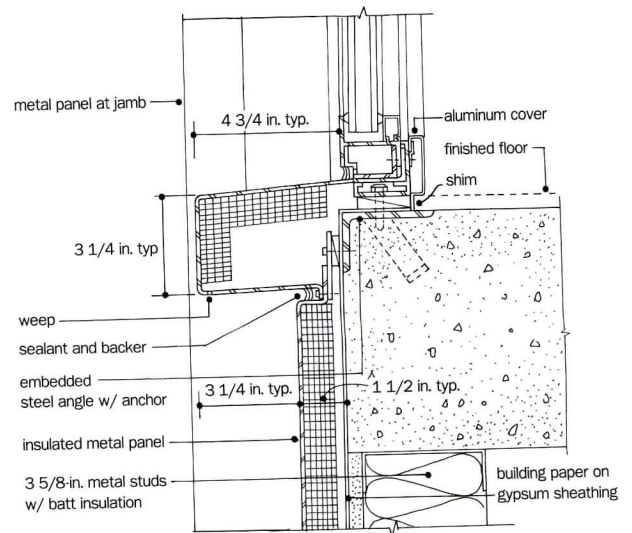

D. TOWER DETAIL AT SILL



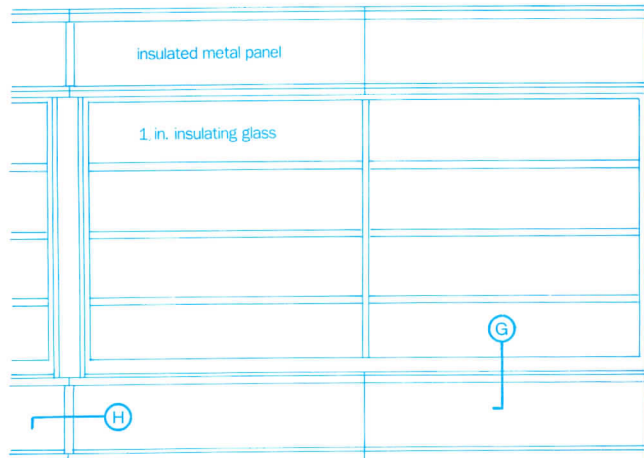

PARTIAL ELEVATION, CENTER

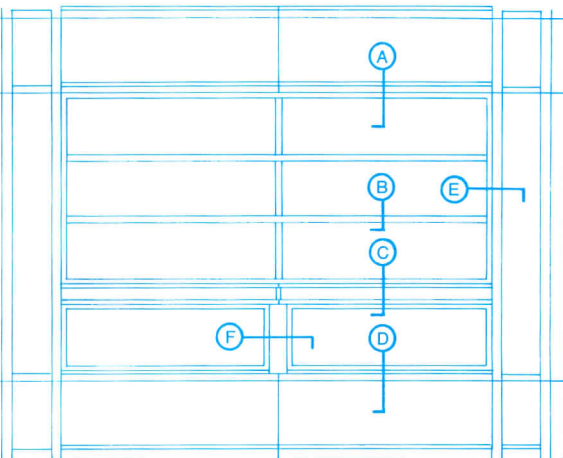

PARTIAL ELEVATION, TOWER

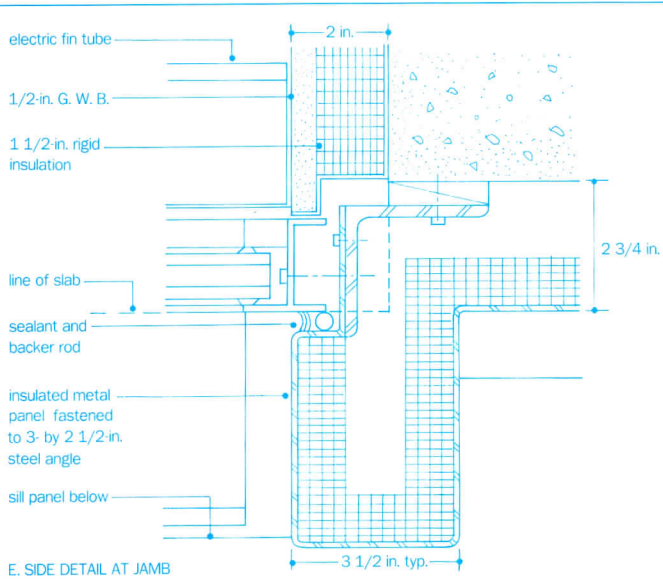

E. SIDE DETAIL AT JAMB

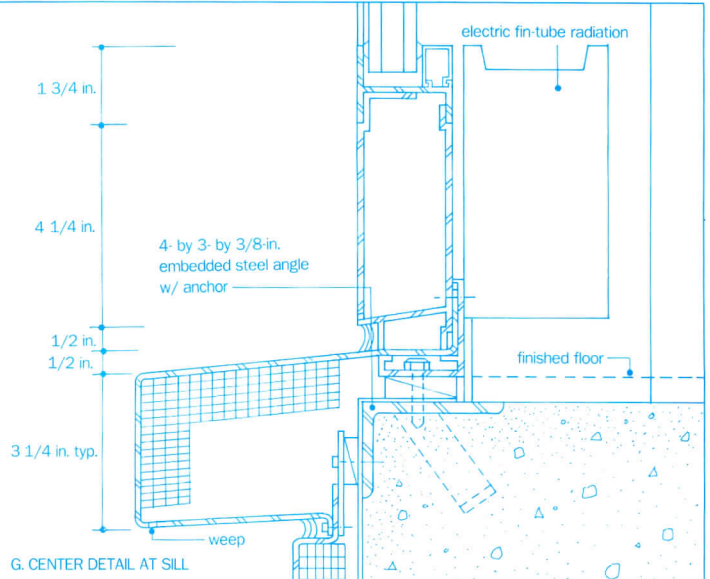

G. CENTER DETAIL AT SILL

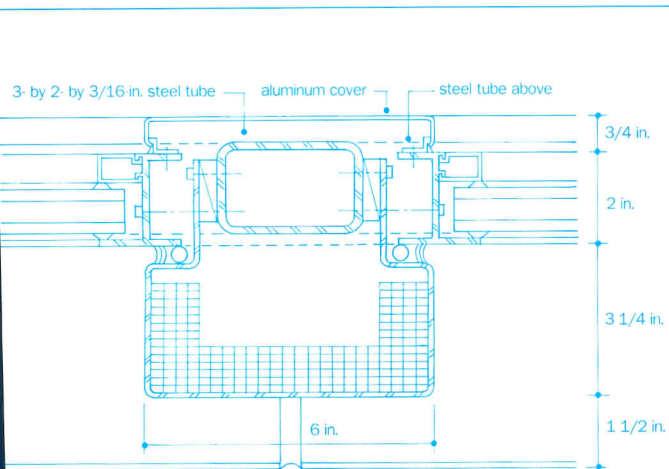

F. PLAN DETAIL, TOWER

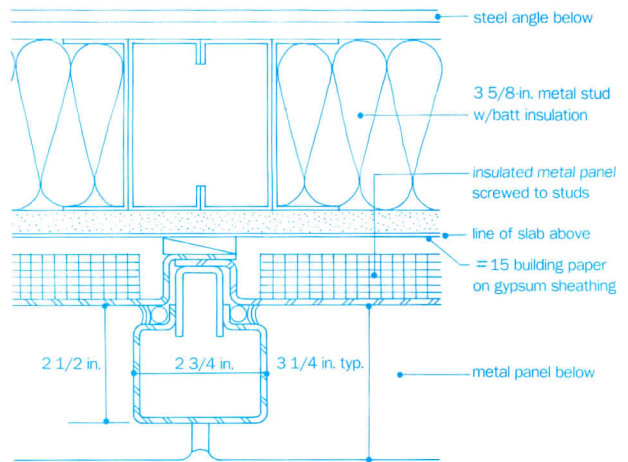

H. CENTER PANEL JOINT



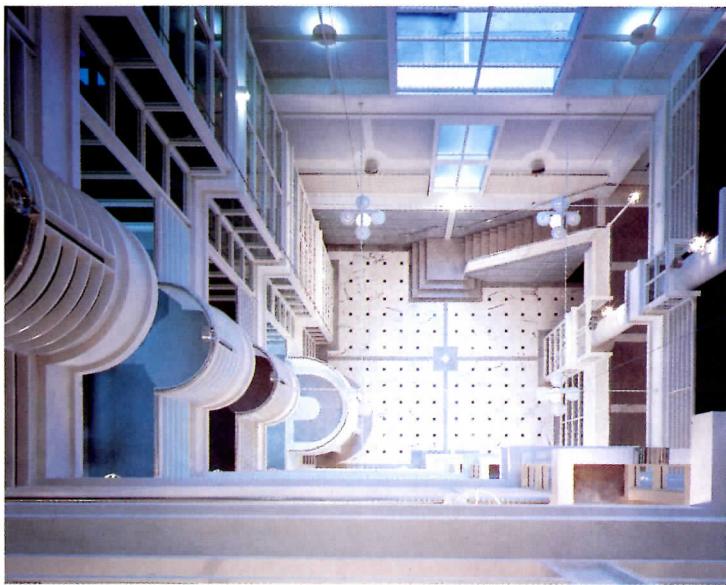

*Removed from the street entrance to the building's inner core, the atrium is not only the principal public lobby but also the key to the exceptional flexibility of the L-shaped plan, which relies on its balcony corridors for internal circulation. Because the space is small in area—only 900 sq ft—Hisaka avoided a bottom-of-a-well effect by adding sky lobbies at the sixth and eighth floors, thus creating independent multistory office suites. Flooded with daylight from the south wall, the atrium restates the exterior curtain wall with simple but elegantly detailed materials—dry wall, glass, and painted metal—in a restrained tones-of-gray palette. Just-for-fun touches include railings and decorative disks of shiny polished steel.*

**Credits**

*1150 18th Street, N. W.  
Washington, D. C.*

**Owner:**

*The Kaempfer Company*

**Architect:** *Hisaka and Associates, Architects, Inc.—*

*Don M. Hisaka, John J. McDonald Jr., design architects; Herman F. Woerner, Ellen S. Light, project architects*

**Engineers:** *James Madison Cutts (structural); Shefferma & Bigelson Company (mechanical/electrical); Associated Engineers, Inc. (civil)*

**Consultants:** *Systems Design Associates (lighting); Ferguson Engineering (fire safety); William Hunt and Associates (elevator/escalator)*

**General Contractor:** *Sigal Construction Corporation*



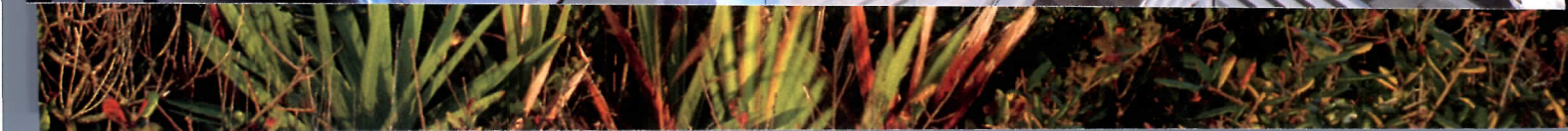



Having grown up near Jones Beach, New York's largest and most popular outlet to the ocean, Roger Ferri thinks of the shore as an informal and thoroughly democratic place. So when he was commissioned to create a beach pavilion for Seaside, Florida, he decided to keep it casual, even whimsical. While some of the other pavilions designed for the innovative town in the Florida panhandle conjure up images of elegant Victorian resorts or Classical temples [RECORD, July 1989, page 102], Ferri saw his project as "a capriccio on vernacular 'stick' construction."

Like the other pavilions, though, Ferri's structure terminates one of Seaside's streets and takes bathers over ecologically sensitive dunes to the beach beyond. Commissioned by the town's developer, Robert Davis, the follies serve as public landmarks, access points to the beach, and, in some cases, playful comfort stations.

With its simple houselike form and distinctive chevron patterning, Ferri's building can be interpreted in a variety of different ways. According to the architect, it can be seen as a beachcomber's shack, a Chippendale fretwork porch, or a palm-frond hut. Due to the configuration of its angled wooden struts, the pavilion reads as either a solid mass or a transparent framework, depending on the vantage point of the viewer.

While the pavilion's imagery is purposely vague, its structure is carefully fixed. Because winds can reach hurricane force along the Gulf Coast, even an open building such as this must be unusually well braced. Using stick construction, Ferri built his pavilion with 2-by-6-inch lumber that has been pressure-treated and then kiln-dried a second time to prevent warping and buckling. Diagonal bracing members establish a chevron pattern that smaller 2-by-2-inch elements pick up as decorative infill.

Rugged weather tests metal fasteners in all of Seaside's structures (indeed, some buildings have already experienced the ill effects of metal corrosion). Ferri consequently eschewed clamps and hinges in favor of direct wood-to-wood connections, using only stainless-steel nails, bolts, and screws. With engineering help from Robert Silman Associates, Ferri has designed a beguiling folly that charms the eye with games of light and shadow, yet impresses the mind with its strict structural logic. *Clifford A. Pearson*

© Steven Brooke photos



#### Credits

*Odessa Street Beach Pavilion*  
Seaside, Florida

**Owner:** Seaside Community Development Corporation

**Architect:** Roger Ferri Architect—Roger Ferri, designer; Maurice Saragoussi, project manager

**Engineers:** Robert Silman Associates (structural)

**General Contractor:** Warnerworks

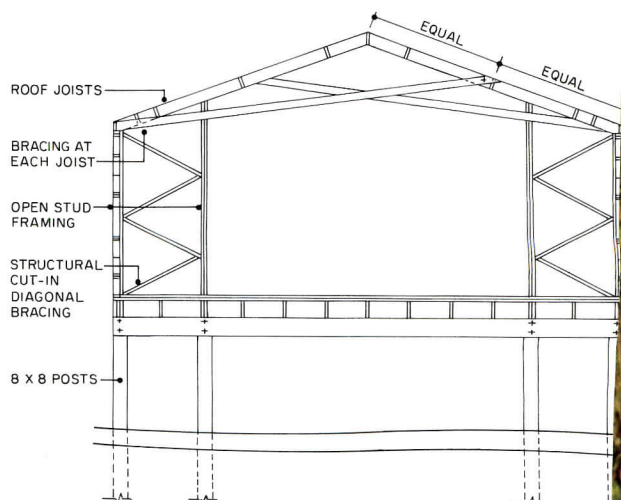







# Two of a Kind

Commenting on her firm's recent work, Denise Scott Brown, of Venturi, Scott Brown and Associates, says, "So many architects feel that they must be original at all costs. We like to be conventional." Compared to some of VSBA's highly assertive past work, this seems disingenuous. Robert Venturi, this year's Pritzker Prize winner, frames it differently: an "analogous" approach may be preferable to a "contrasting" one—especially for such complex commissions as research laboratories. Two cases in point, designed with Payette Associates, are the Clinical Research Building at the University of Pennsylvania (right) and the Thayer School of Engineering at Dartmouth (opposite), the latest in a series of Payette/VSBA labs that began with the Lewis Thomas laboratory at Princeton [RECORD, August 1986, pages 104-113] and includes a not-yet-finished lab at UCLA and additional projects for both Penn and Princeton.

Being "conventional" for a lab building is not confined to the massing or the elevations, which are VSBA's turf. To accommodate an enormous range of research needs (many of which are unknown during design), the architects' burden is to find an all-embracing conceptual framework, then to avoid applying it indiscriminately (see also RECORD, February 1991, pages 97-109). Having worked together on several projects, "There is now a certain anticipation of how the other firm thinks," comments Jim Collins, Jr., of Payette. Even so, the team must, according to Collins, "start from scratch and think each project through, tailoring it to the personality of the client." Though they are apparently quite different, this pair of buildings shares a singular antecedent, what Venturi calls "the noble tradition of the industrial loft."

The loft is seen as so simple and open-ended in structure that it can adapt to myriad activities. The Clinical Research Building, though it serves nine departments, is organized through a straightforward rectangular plan, with consistent modular bay spacing, and with special function rooms and mechanical shafts placed in a central core.

© Matt Wargo photos



*Clinical Research Building  
University of Pennsylvania  
Philadelphia, Pennsylvania  
Payette Associates, Inc., Architect  
Venturi, Scott Brown and Associates,  
Associated Architect*



*A pair of research laboratories,  
the latest projects in two firms'  
years-long collaboration,  
represents an evolutionary  
approach to a tough building type.*



*Thayer School of Engineering  
Dartmouth College  
Hanover, New Hampshire  
Venturi, Scott Brown and Associates,  
Architect  
Payette Associates, Associated Architect*

The edges are left free for laboratories (on the long north and south sides) and offices and lounges (at the short ends). Though at first glance similar to Lewis Thomas, this is not a knee-jerk reworking. The exterior of the CRB is more prismatically slablike, the elevations patterned more discreetly. Within this envelope, Payette has worked subtle changes on the Princeton parti (pages 82-83).

At Dartmouth, the study of many kinds of engineering occurs in one research-oriented undergraduate and graduate program. "We have long felt that the traditional curriculum emphasizes *differences* among engineering fields," explains John Strobain, provost at Dartmouth. "Here students receive a fundamental basis. We think they'll be more successful if they can move across boundaries." With this in mind, it became important to unite the enormous breadth of Dartmouth's engineering activities under one roof—a roof that had already been enlarged twice. The existing building at Dartmouth did not lend itself to the linear modularity of Penn. Instead, old and new spaces were divided into independently serviced suites. A double-height central meeting space, dubbed the Great Hall, is the nucleus around which the building—and the academic program—revolves.

One could argue that the architects have been *too* smugly conventional. Should the CRB's exterior have been a little more modeled, Thayer's plan tidier? By contrast, and only a block from the CRB, the profoundly influential Richards Medical Laboratory (completed by Scott Brown's and Venturi's mentor, Louis Kahn in 1961) is lab architecture at its most audacious. Both Dartmouth and the CRB are intentionally opposed to Richards's hyperspecific distinction of program functions and the monumentalizing of the mechanical systems (the famous division of "servant" and "served" spaces). And the architects don't apologize for a less expressionistic—and less expensive—approach. "Scientists are not priests," comments Venturi. "They don't need a cathedral, but a place that acknowledges the dignity of labor." *James S. Russell*





### Clinical Research Building University of Pennsylvania

Modular, generic labs—evocations of open-ended industrial loft space—were seen as the most flexible solution to ever-changing research needs in this 175,000-square-foot facility. The building's boxy shape came about, according to Ian Adamson, of VSBA, "because of pressure to bring in these very expensive buildings as economically as possible." Re-entrant corners were introduced, according to Venturi, "to keep it from being completely '50s." Since floor-to-floor height was unusually large, VSBA sought to reduce the apparent depth of the spandrel bands and the visual thickness of the windows' aluminum mullions by scaling them up. They are proportioned, however, to resemble those of older Collegiate Gothic structures nearby. Differing functions within the building are expressed by minor variations in window rhythm (overleaf). The exaggerated diaper-patterned brick at Princeton's lab is here refined. (Venturi calls it "plaid" vs. "tweed"—opposite.) At the mechanical penthouse, recognizably human-sized windows placed next to giant ventilation louvers are cues to their monumental scale (drawing left). Penn's stylized coat-of-arms is mounted like a Classical escutcheon on porcelain-enamel "wallpaper"—an icon of the campus visible from the nearby Schuylkill Express way (top left).

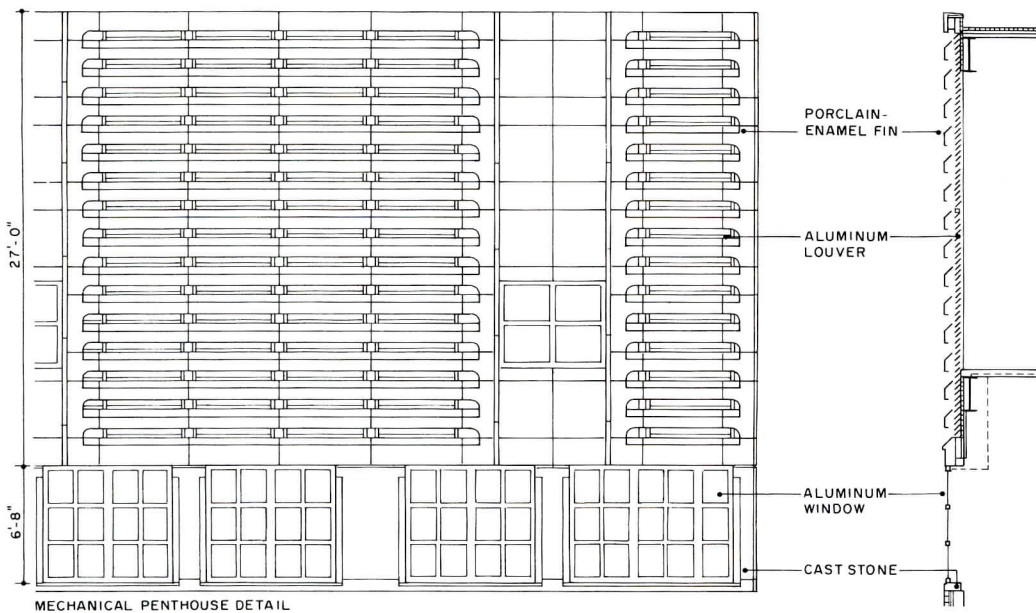











he CRB includes wet-lab research on cancer, the brain, dermatology, and work for the Howard Hughes Medical Institute. "To lower barriers between different disciplines," says Jim Collins, Jr., "departments have been arranged to bump up against each other." Other means are also used to foster interaction. On a typical floor's north side, researchers can pass through adjacent "open" labs, though not so readily as at Princeton. (Fume hoods are located in alcoves nearest the core to keep lab space free and reduce utility runs.) Cross corridors penetrate the core at intervals and are wide enough to house support equipment. A generous lobby, lounges, and a café (opposite) also act as meeting places. Other niceties: Administrative areas open off elevator landings—the building's "public" center; interior windows bring outside light and lab views into the main corridor (opposite top right).

**Credits**

**Clinical Research Building**  
 Philadelphia, Pennsylvania  
**Owner:** University of Pennsylvania  
**Architect:** Payette Associates—David Rowman, principal-in-charge; Jim Collins, Jr., project architect; Len Davis, Dan Scienza, Tom Davies, David Emus, Greg Ettridge, Bob Haeffner, Pat Strangle, Franne Fish, project team  
**Associated Architect:** Venturi, Scott Brown and Associates—Robert Venturi, principal-in-charge; Ian Adamson, Michael Peters, project managers; Eric Aukee, James Kolker, John Bastian, John Forney, James King, Amy Klee, Robert Parker, Catherine Murray, John Rauch, Charles Renfro, John R. Trowbridge, James Ankler, F. Christian Wise, project team  
**Engineers:** Simpson Gumpertz Heger (structural); Robert J. [unclear], Inc. (mechanical)  
**Construction Manager:** [unclear] Henderson Corporation

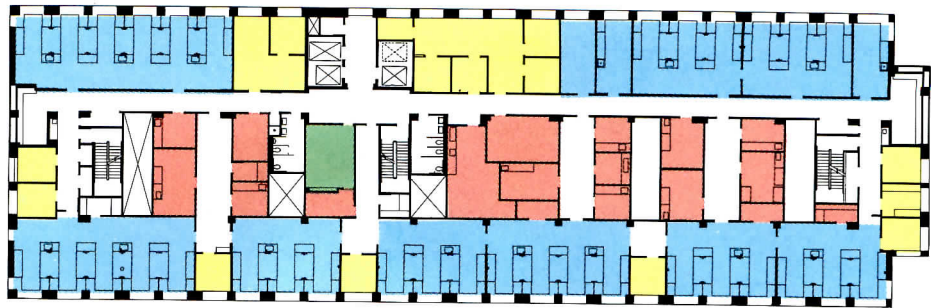

TYPICAL FLOOR



SECOND FLOOR



FIRST FLOOR

■ LAB   
 ■ SUPPORT   
 ■ OFFICE   
 ■ CLASSROOM



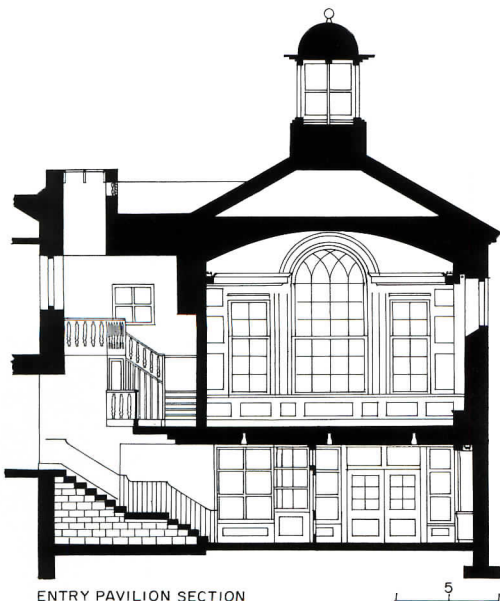

ENTRY PAVILION SECTION

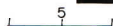

## Thayer School of Engineering Dartmouth College

The existing structure offered inauspicious raw material. Its U-shaped plan (below) is awkward for labs; its exterior was timid compared to such flamboyantly Neo-Georgian neighbors as the Tuck School of Business. Also, sophisticated functions had to be shifted to the addition and existing projects maintained during construction. Inevitably, the solution is neither as straightforward nor as cleanly resolved as the CRB. At the front of the building a new entrance pavilion gives the school a more assertive presence among its neighbors (top left). Its Palladian window (opposite) is a familiar image on campus. (Venturi confessed that it "might have been gutsier" had it been larger.) A reconfigured entrance vestibule at grade leads up cascading stairs to the main level (page 87). This is surmounted by a handsomely finished conference room, now a favorite of college trustees. The laboratory "loft" added at the back is an austere rendering of a New England mill: big, double-hung windows are tied together by a thin, flat, granite string course (left). Venturi sums up the parti as "Queen Anne front, Mary Anne behind."

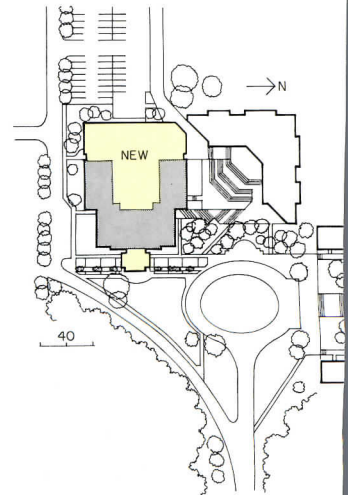







For best use of space, the existing structure (built in 1939, added to in 1948) was divided into suites housing offices or labs. Sprinklers were added, mechanical shafts were enlarged, and mechanical services upgraded, but existing hot-water radiation was retained. In the new rear wing, computer labs and two clean rooms for silicon-chip fabrication are on the top floor, near hvac equipment. The basement houses a project studying the structural properties of polar ice (biggest, heaviest, dirtiest, and noisiest of the labs) and optics labs housing lasers (which require special vibration-isolation tables). Sandwiched in between are labs for materials science, mechanical engineering, biomedical and biotechnology, and computers and computer graphics. These disciplines are united by the clerestory-lit, double-height Great Hall, overlooked by study rooms (opposite top).

**Credits**

Thayer School of Engineering  
Hanover, New Hampshire

**Owner:** Dartmouth College

**Architect:** Venturi, Scott Brown and Associates—Robe Venturi, partner-in-charge; Roc Caivano, Thomas Beck, project managers; Ian Adamson, John Bastian, Catherine Bird, Catherine Cosentino, John Forney, David Franke, Susan Gallagher, Sharon McGinnis, David Perkes, Mark Stankard, Jam Winkler, project team

**Associated Architect:** Payett Associates—David Rowan, principal-in-charge; Wendy Edwards, Jonathan Rollins, project managers; Douglas Cover, Bruce Fullerton, Kim Thomas, Erica Steenstra, project team

**Engineers:** Simpson Gump & Heger, Inc. (structural); R Vanderweil Engineers, Inc. (mechanical); Soils Engineering, Inc. (geotechnical)

**General Contractor:** Jackson Construction Company

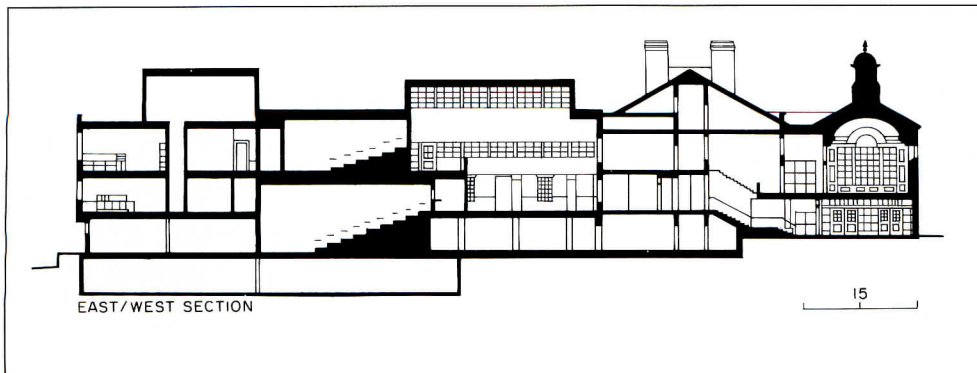
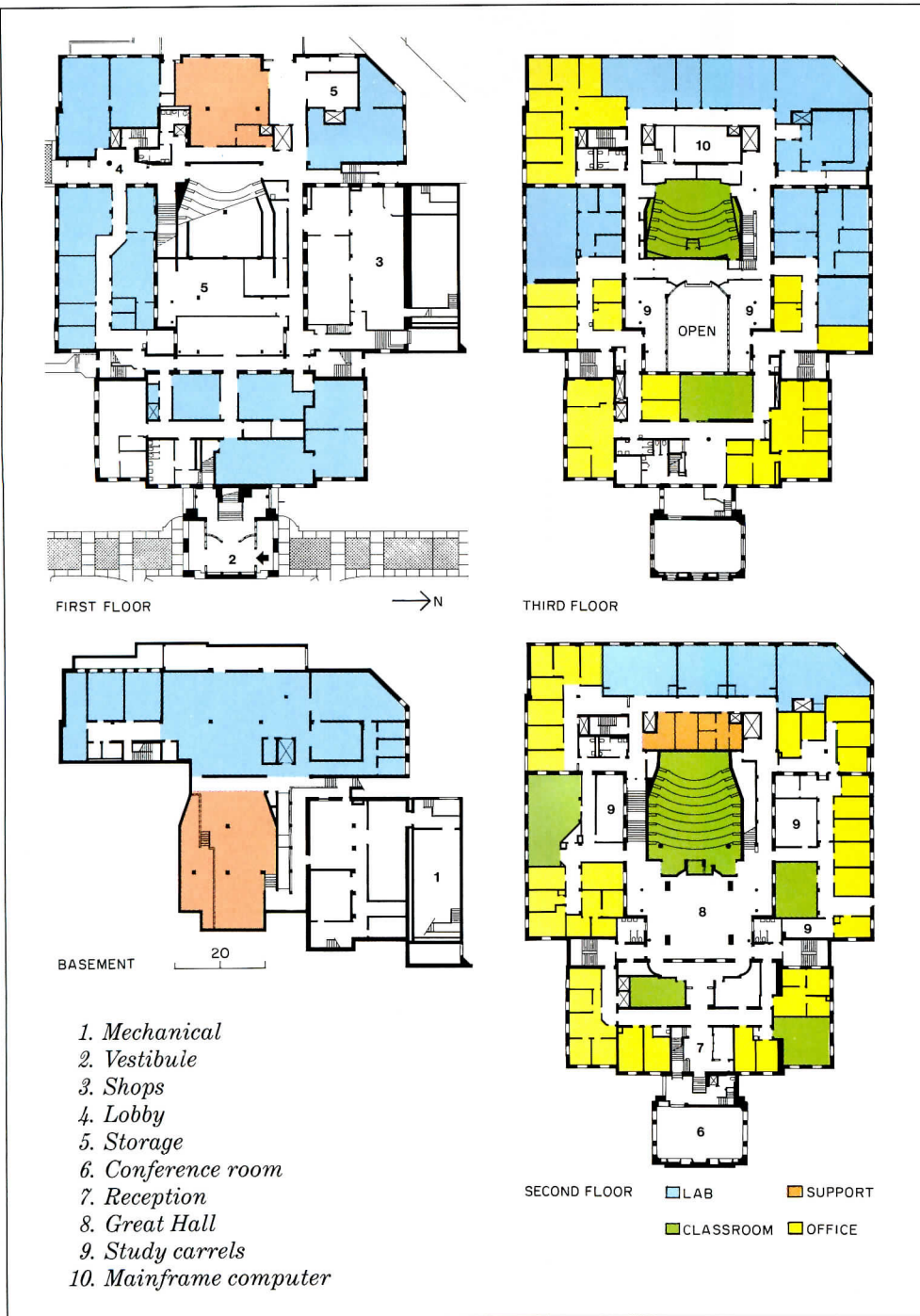







**A** generation ago, saving even one Frank Lloyd Wright-designed room from extinction seemed like a futile act of generosity. In the last decade, though, the rising value of Wright artifacts has threatened the integrity of those scarce structures that retain his furniture and other architectural elements [see "Collecting Frank Lloyd Wright: Vandalism or Public Service?" RECORD, July 1988, page 67]. Ironically, one is more likely than not to see Wright's decorative objects out of context—a sad fate for works of "organic" design. Thus, restoration of the Dana-Thomas House in Springfield, Illinois, complete with its original Wright-designed furnishings, is cause for rejoicing.

A combination of luck, vision, and perseverance conspired to preserve this treasure. The house, commissioned in 1902 by Susan Lawrence Dana as an expansion of her father's 19th-century Italianate villa, was completed in 1904—a 12,600-square-foot grouping of powerful public and intimate private spaces. Once a mecca for Springfield's progressive politicians (it sits a few blocks from the state capitol) and later center of the city's cultural life, the house deteriorated in mid-century as Dana's fortune and health declined.

In 1943 Dana sold the house and furnishings to Charles and Nanette Thomas, who used the structure over the next 35 years as offices for their small publishing company. The Thomases respected Wright's work and held the ensemble together as well as they could within limited means. In the late 1970s, the house caught the eye of Illinois Governor and antique collector James Thompson, who convinced the state to acquire the building. Thompson personally oversaw fundraising for the \$5-million restoration, and for re-acquisition of several missing objects. (One double-pedestal lamp, for example, was bought for \$750,000.)

Now open free to the public, this rich work offers the most complete set of furnishings and decorative art of any extant Wright building. What is more, the house captures Wright just before he codified many of the spatial and decorative features of the Prairie School. There is a fussiness here in Wright's spatial acrobatics, which in later houses became more fluid and horizontally extended. Likewise, his decorative schemes for later houses were simpler and more clearly integrated into the overall design.

A group of specialized craftsmen, overseen by architects Hasbrouck Peterson Associates, completed the restoration in three phases over three years. Exterior work included replacing the plaster frieze under the eaves (overleaf and right) and covering art glass with new theft-resistant storm windows. The architects repaired poorly pointed brickwork, including the recessed horizontal joint Wright had designed, and patched spalled colored concrete. Inside, they duplicated the lustrous texture of Wright's original plaster. Turn-of-the-century wiring remains but has been bypassed by new (the house was among the first in Springfield to have electricity installed at construction). Wright's innovative concealed lighting systems have been restored to their original condition.

Architects in particular will marvel at the puzzlelike quality of the plan as it pinwheels out from the central dining room, and visitors will appreciate the soft iridescent light that filters through hundreds of pieces of Wright's art glass. The intricate progression of spaces may be closer to the architecture of Sir John Soane than to the mature Prairie Style of, say, the Martin House in Buffalo, which was begun less than a year later. Perhaps more than any other Wright work, then, the Dana-Thomas House stands as both coda to the 19th century and prelude to the 20th. *Anders Nereim*

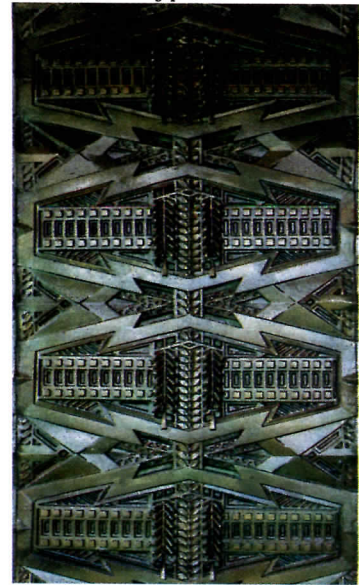

*Wright experimented with many ideas in the Dana-Thomas House, only to abandon them in his mature Prairie Style houses. Upswept eaves (opposite) lent the house an oriental air that was somewhat controversial at the time. Gallery glazing rises past the springing of the vaulted ceiling within. Though the exterior plaster frieze (above) had been removed, it was reconstructed from an original mold and finished with green and bronze glazes that mimic the variegated leaves of a chestnut tree in the courtyard. The frieze patterning anticipates the American Art Deco style.*









Dulled by successive layers of paint, the warm, three-dimensional quality of the interior plaster finish—made by a technique called *scumbling*—has been recreated by Micky and Lee Thompson. The artisans wiped coarse sand in the finish coat before drying to expose a tooth, then brushed the surface with a priming coat of stain. A sponge-mottled second coat of stain was finished with a low-gloss glaze. Top left: the three-story, split-level entrance hall. Top right: the vaulted gallery occupies a near-separate pavilion. Bottom left: Richard Bock's *The Flower in the Cran-nied Wall* still stands in the entry niche designed for it. Bottom right and opposite: the dining room, lit by delicate art-glass lamps, is arguably the most important space in the house. Susan Dana's guests dined to music from a curtained balcony. George Niedecken's mural of sumac, goldenrod, and purple asters, lit from below, is the only surviving Niedecken frieze in any Wright house.

1. Balcony
2. Open to below
3. Bedroom
4. Nursery
5. Master bedroom

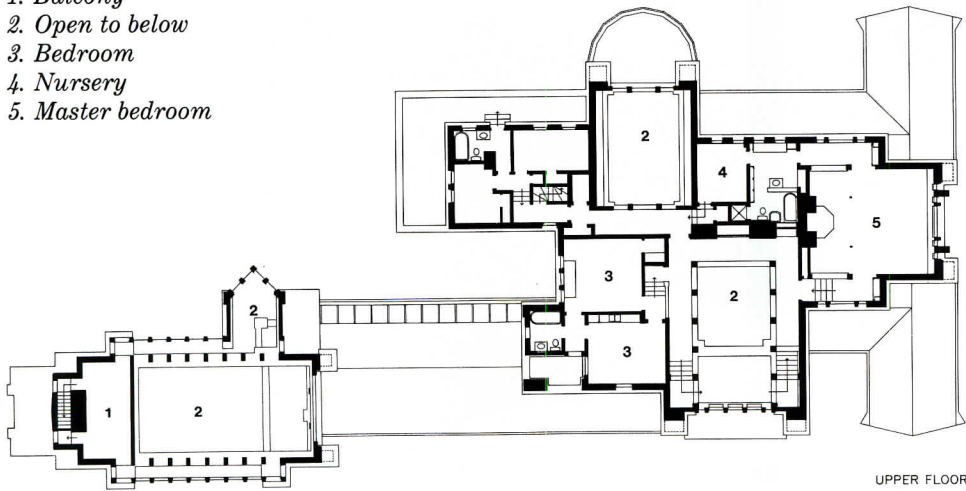

6. Gallery
7. Conservatory
8. Servants
9. Breakfast nook
10. Dining
11. Reception hall
12. Parlor
13. Living room
14. Porch

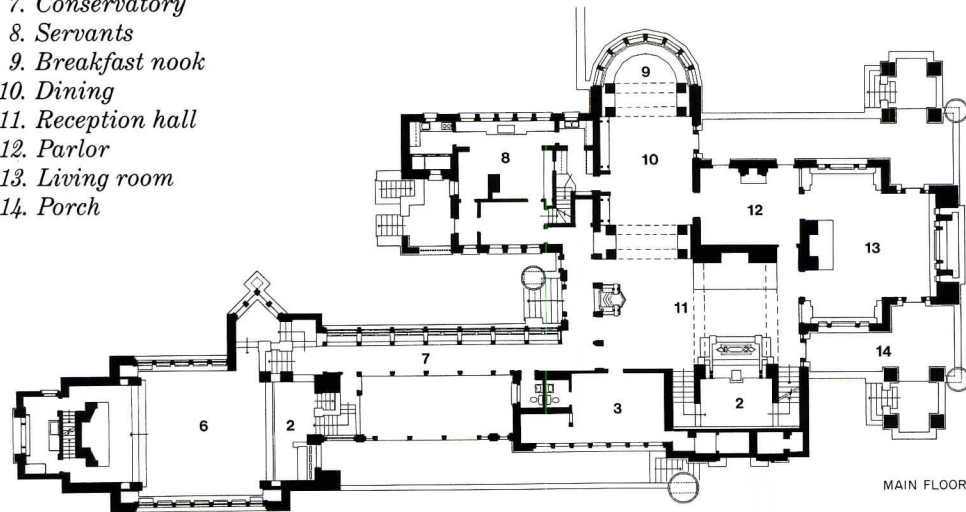

15. Library
16. Bowling alley
17. Office
18. Coat room
19. Billiard room
20. Entry
21. Archival storage

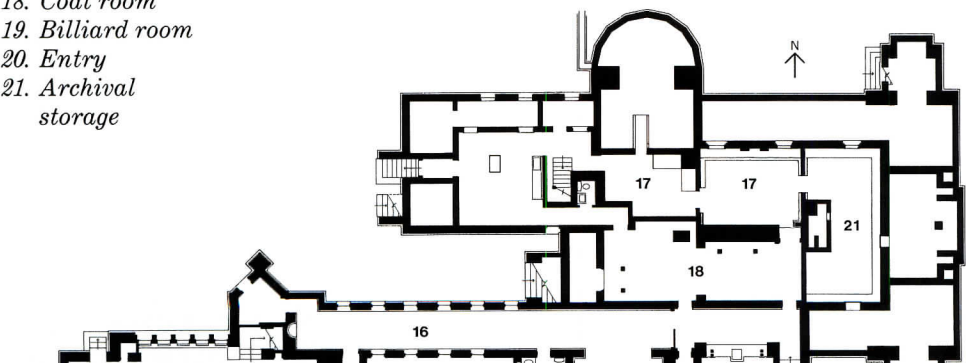

The house's new use as a museum presented some difficult decisions. A forced-air hvac system was added even though some critics saw mechanical cooling as untrue to the original structure. In the end, the state decided that air conditioning would help preserve valuable artifacts and assure visitor comfort. Replacement rather than repair of interior plaster was also criticized. (Repaired-only surfaces were thought to be subject to damage by visitors.) Finally, some critics find the red-orange color of refinished woodwork distinctly un-Wrightian. The color reflects, according to Will Hasbrouck, the prevailing sumac theme executed by Wright in lamps, a frieze, and art glass. "When the leaves turn in fall, it matches magnificently," he says. Top left opposite: a niche adjacent to the gallery. Top right opposite: the conservatory. Bottom left opposite: Wright-designed chairs, lamps, glass, and armoires in the master bedroom. Bottom right opposite: breakfast nook off the dining room.

**Credits**

Restoration of the Dana-Thomas House Springfield, Illinois  
**Owner:** State of Illinois—Donald Hallmark, site manager; Mike Jackson, project manager  
**Architect:** Hasbrouck Peterson Associates—Wilbert R. Hasbrouck, partner-in-charge; Kate Klein, project architect; Lesley Gilmore, site observation  
**Engineer:** Gassman Engineer Inc. (mechanical, electrical)  
**Consultants:** Gage-Babcock & Associates (security and fire protection); Moss, Johnson & Associates (landscape); David







# Not Just Another Mall





*A new urban marketplace on an abandoned canal brings life to a rundown industrial district near Boston.*

*CambridgeSide Galleria  
Cambridge, Massachusetts  
Arrowstreet Inc., Architect*









cross the Charles River from Boston is a part of Cambridge that was, until recently, little known and less visited. Once a center for light manufacturing, the East Cambridge riverfront had become, by the 1970s, a no man's land of vacant lots and empty warehouses. Yet its potential was unmistakable. The site afforded more than prized river frontage: flowing in from the Charles was the long-neglected, turn-of-the-century Lechmere Canal, and to the west lay a pleasant neighborhood of modest 19th-century wood houses and handsome brick and stone civic buildings, including a Bulfinch courthouse.

In 1978, the Cambridge Planning Board adopted the East Cambridge Riverfront Plan. A master plan for the redevelopment of 60 acres, it proposed a mix of apartment houses, office buildings, and stores, all connected by a network of parks. This thoughtful plan, which combines Beaux Arts and Olmstedian principles, is now 90 percent complete, and at its heart is the 10-acre CambridgeSide Galleria, a 770,000-square-foot, three-story shopping mall that has become, since opening last fall, a recession-defying success.

Like many large urban projects, CambridgeSide is the product of a long, sometimes tense but ultimately satisfying collaboration among municipal client, private developer, and architect. Hired by the developer in 1984, the architects, Arrowstreet Inc., spent three years developing dozens of schematic designs. "The developer was most familiar with suburban malls, while the city was looking at prototypes ranging from Quincy Market to the Galleria in Milan," recalls project designer Brad Edgerly. Indeed, the architects' challenge throughout was to reconcile the developer's preference for a secure, introverted, chock-full-of-parking mall, with the city's vision of a pedestrian mecca, a lively marketplace with fenestrated facades, multiple entrances, and unobtrusive underground parking.

Thanks to unorthodox planning, CambridgeSide manages to be both city market and regional mall. The heart of the complex is a 540-foot-long, 81-foot-high-arcade that, as the city specified, is on axis with two new municipal parks (it is also parallel to the city's major streets). Also unconventional is the vertical disposition of spaces. The street level is reserved for small stores and food shops, while anchor stores are accessible from the upper levels. To enhance the sense of the arcade as interior street, the architects chose hard-worn, durable materials—e. g., polished and flame-finished granite floors and exposed steel trusses above.

Most retailers are notoriously wary of street-facing windows, and developers are none too fond of articulated facades. Here, too, CambridgeSide breaks with convention. "We wanted [the project] to be traditional in feel, but modern in interpretation . . . cohesive but not monolithic," says Roger Boothe, Cambridge's director of urban design. To these ends, the architects have designed energetic elevations that combine Woodbury granite bases, water-struck brick walls, cast-stone and limestone trim, metal-clad exposed structure, and numerous windows. To reduce further the perceived scale of the mall, each anchor store has a distinct identity.

CambridgeSide's long gestation and atypical results have spurred Arrowstreet's president, Robert Slattery, to argue that this much-neglected building type should receive a lot more attention from architects, and that public/private collaborations produce better results. "Shopping has become so much a part of American culture that the malls have become, in effect, major civic buildings. They're important now to be determined mainly by retailers' formulas."

by Nancy Levinson

### Viewpoint, by Robert Campbell

*On the historic Lechmere Canal, a new development is attempting to combine the virtues of a suburban shopping mall with those of an urban "festival marketplace." Like a standard mall, CambridgeSide Galleria has three big anchor stores at its ends. Between them there's the usual skylit arcade, three stories high and lined with a zillion shops. But unlike a mall, CambridgeSide fronts the streets around it with welcoming doors and windows and handsome materials, not with asphalt deserts and blank stucco walls. And it opens itself to a lovely water park, a place for picnics and for boat excursions out onto the Charles River.*

*CambridgeSide's design team had three anchors, too. One was the architect, Arrowstreet, Inc. The second was the developer, an inventive outfit called New England Development. The third, and in some ways most important, was the city of Cambridge. In 1976 Cambridge, with consultant Dennis Carlone, published a visionary master plan for a new mixed-use neighborhood to replace what had been a derelict wasteland. Cambridge stuck to its plan through long and difficult negotiations. CambridgeSide Galleria is part of that massive plan, as are present and future offices, shops, and housing. It is surely one of the better American malls. Its heart is a visually flabbergasting block-long atrium, a feature that hardly distinguishes it from a lot of other malls. But, for once, this atrium isn't buried like a tomb deep in an ugly mass of construction. It opens with trust to the city around it.*

*CambridgeSide's feeling of openness is strongest at the water end. Here the Galleria's atrium widens into a food court. The court in turn sweeps out in a curve to embrace a public water feature—Canal Park—which landscape architect Carol Johnson created for the city from the weedy old Lechmere Canal. Picnickers can stroll directly from the food court out to this urban water garden, especially delightful at night amid the sparkle of the stars, the Boston skyline, and an illuminated 100-foot spume of water.*

*In the boom of the 1980s, Cambridge was able to mandate costly materials: water-struck brick, pink granite, limestone. It insisted on facades with enough glass to bring a view of the indoor action to the edge of the sidewalk. Doors open directly from the sidewalk into two of the anchor stores—Lechmere and Sears—and will open in the future into restaurants. You get a sense of real urban life, less than hectic, to be sure, but a lot better than the neutron-bombed DiChirico streetscapes of most American retail cores.*

*Plugging CambridgeSide into a city grid wasn't easy. Most of the 2,537 parking spaces are tucked expensively under the water table. So is the truck service. Some of the parking need is relieved by a shuttle bus that arrives every 15 minutes from two nearby subway stops. When you do park, you don't skulk, ratlike, toward a scary elevator. Instead a shaft of light penetrates the parking levels, beaming you up through a bright lobby and escalator to the shopping heaven above. Arrowstreet admits the influence of city planners on its design. But the architects added much. They paved the atrium in patterned stone to make it an indoor street instead of a beige-out corridor, then echoed the area's industrial past with a tracery of steel trusses at the gabled skylight.*

*Child of the flush '80s, CambridgeSide opens in the nervous '90s. The success or failure of this ambitious attempt to be both urban and suburban may tell us something about the future of retail in the city.*



Courtesy of Arrowstreet (below); © Steve Rosenthal (opposite)



© Robert Mikrut



1. Arcade
2. Retail
3. Service
4. Food court
5. Lechmere
6. Sears
7. Office
8. Housing
9. Lechmere Canal
10. Canal Park

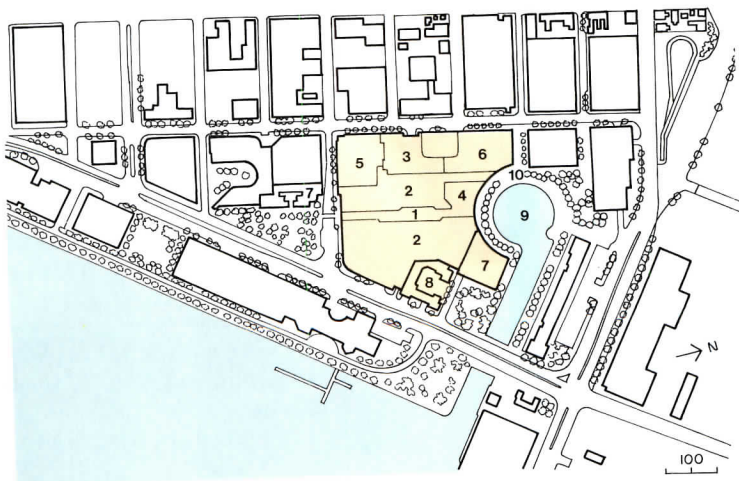

Influenced by Beaux Arts planning principles, the 1978 East Cambridge Riverfront Plan establishes a strong axis between the city and the new development (site plan bottom). Residential, retail, and office buildings are connected by a network of open spaces. CambridgeSide's 540-foot-long arcade is on axis not with department stores but with two new municipal parks. Canal Park (pages 96-97), the transformed Lechmere Canal, was designed by Boston landscape architect Carol Johnson and built in the early 1980s with UDAG funds. Work on Charles Park, on the arcade's southern end, will begin soon.

Multiple entrances, vigorously articulated facades, and street-facing windows (page 98) distinguish CambridgeSide from most other malls. To reduce the 10-acre building's scale, the architects gave each anchor department store a distinct identity (Filene's is shown at left). Colorful banners and signage, the work of environmental designers Fitch Richardson Smith, further enliven the building.

Parking was one of the knottiest planning issues. The city's urban designers wanted it underground, but New England Development initially balked at paying for expensive subterranean construction. The developer also sought more parking than the city would permit. In the end, two-thirds of the 2,537 parking spaces are on three underground levels. Arrowstreet reduced some of the grimness of below-grade garages by extending the escalators down to all levels and including elements such as the management office, security station, gift wrap, and post office at each landing. The above-ground garage (opposite) uses the same water-struck brick walls and limestone and cast-stone trim as the rest of the project.





© 2000 CambridgeSide

CambridgeSide

CambridgeSide

CambridgeSide

CambridgeSide

Centre Bakery

CambridgeSide



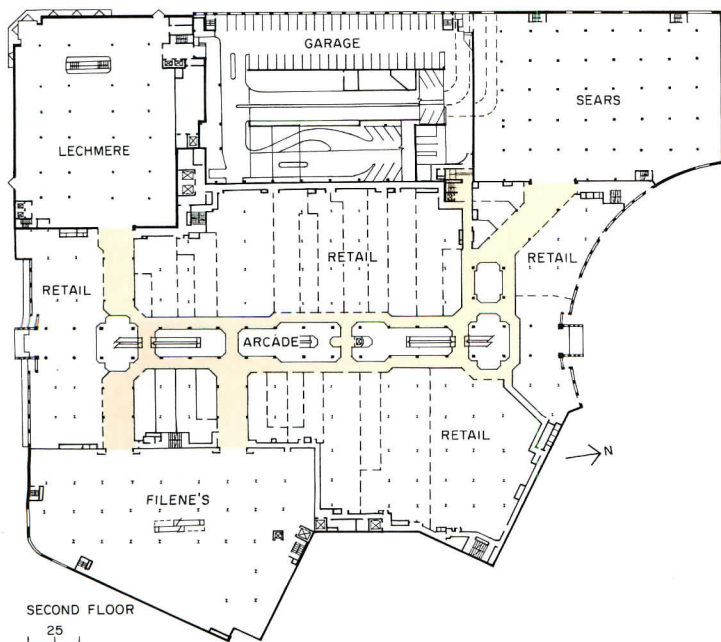

To underscore the sense of arcade-as-street, the architects chose durable, hard-edged materials for CambridgeSide's interiors: polished and flame-finished granite for the street-level floor, metal channels and angles for railing and elevator-tower details, and exposed steel trusses. Small shops and a food court occupy the street level (middle left), while three large anchor stores are reached from the upper levels. CambridgeSide's gabled skylights, which admit 30 percent of the project's total illumination, are made of insulated glass panels coated with reflective metal on the exterior (top left and opposite). Brass sconces crowning interior columns are custom designed.

**Credits**

**CambridgeSide Galleria**  
 Cambridge, Massachusetts  
**Owner:** New England Development

**Architect:** Arrowstreet, Inc.—Robert Slattery, principal-in-charge; James Flajnik, project architect; Brad Edgerly, design principal; James Batchelor, planning principal; John Shortall, Gareth Wohl, Linos Dounias, Kevin Kerchaert, Peter Belford, Paul Farrell, Neil Edwards, Chuck Leonard, Mary Hickie, Gabriel Zavala, John Felix, Grant Gustafson, James Linville, Gina Sonder, project team

**Engineers:** Weidinger Associates (structural); TMP Consulting Engineers (mechanical); Johnson & Stover (electrical); Goldberg-Zoino & Associates (geotechnical); H. W. Moore Associates (civil)

**Consultants:** Theo Kondos & Associates (lighting); Fitch Richardson Smith; Clifford Selbert Design (graphics); Sa Saliponte (landscape); Lerch Bates & Associates (vertical transportation); Jack Van Stone Fogg (specifications)

**General Contractors:** Beaver Builders (galleria and garage); J. J. Vaccaro (Lechmere)







# Dances With Stone





*A new museum of American  
Indian and Western art in  
Indianapolis captures the spirit of  
native American building without  
resorting to predictable forms.*

*Eiteljorg Museum of American  
Indian and Western Art  
Indianapolis, Indiana  
Browning Day Mullins  
Dierdorf, Architect*











Though located on the edge of downtown Indianapolis, the museum is set apart from the city by a large lawn (previous pages) and by its situation at one end of White River State Park. A sense of separation is enhanced by a wall encircling the building (foreground, opposite). An entry canopy (photo above and section, below right) recalls shaded arcades in Indian pueblos. A sculpture court (opposite) is formed by teak screens set below a stone-clad bridge that disguises a fire exit and emergency stair.

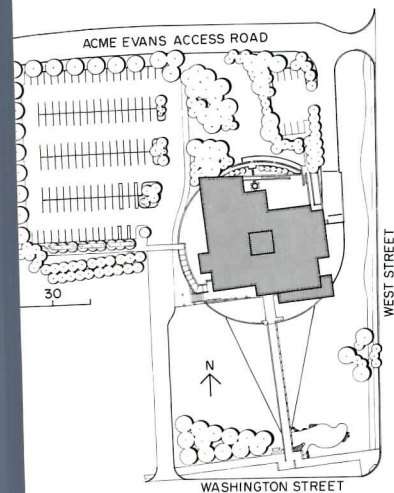

Set between the Hoosier Dome and the Acme-Evans grain elevator, the Eiteljorg Museum of American Indian and Western Art is an unlikely addition to downtown Indianapolis. What, one might ask, is a museum of Indian art doing in a part of the world better known for car racing than cave painting? The answer, of course, has more to do with the residency of a particular art patron—Harrison Eiteljorg—than pure reason. That the building seems so comfortable on its site, therefore, is no small achievement.

Architects Browning Day Mullins Dierdorf calmly disregarded the architectural examples set by Indianapolis's latest buildings (such as the adjacent state office complex), as well as those of its agrarian past. Instead, the museum plays by its own rules. Sitting on a gentle hill and surrounded by a 10-foot-high circular stone wall reminiscent of native American ceremonial kivas, the Eiteljorg stakes out its own territory, closer in style to the pueblos of New Mexico than the state capitol of Indiana. While none of the 73,000-square-foot building's forms is a literal representation of Southwestern architecture, its simple geometry and the architects' use of cut stone capture the spirit of the cliff-dwelling Anasazi Indians.

"Coming from the Midwest, I struggled to find a proper expression of the Southwest," admits Jonathan Hess, the principal-in-charge of the museum's design. In the end, what the firm took from the Taos and Santa Fe region of northern New Mexico was an appreciation of the Anasazi's masonry skills. As a result, Hess and his associates sheathed the steel-frame structure with desert-hued Minnesota dolomite cut into 2-by-4-foot blocks. To add texture and shadow lines to the great expanses of stone-clad facades, the architects extended some courses an inch in front of the others. The same dolomite sheathes the upper portion of a circular surrounding wall, while rough-textured red sandstone covers the base. And as the Anasazi often did, the architects canted the wall three degrees.

A 90-foot-long entrance canopy, supported on columns of Western red-cedar tree trunks, establishes a procession that takes visitors from contemporary Indianapolis to the timeless world of native American art. As the canopy suggests, the architects used wood to complement stone surfaces on both the exteriors and interiors of the museum. Teak screens and siding in the north sculpture court and teak windows grace the exteriors, while mahogany takes over window trim, counters, and cabinets inside.

At the center of the museum's floor plan is a two-story, barrel-vaulted stair hall, which provides access to all of the galleries. Behind the stair the architects created a peaceful room where groups can gather and art-weary visitors can take in views of the sculpture court and its fountain. *Clifford A. Pearson*

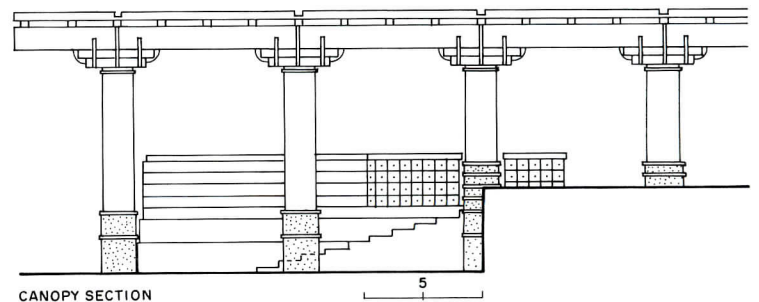





Galleries (bottom) are shielded from sunlight, but clerestories grace the stair hall (top). A lounge overlooks the sculpture court (opposite).

**Credits**

*Eiteljorg Museum of American Indian and Western Art  
Indianapolis, Indiana*

**Owner:** Eiteljorg Museum

**Architect:** Browning Day Mullins Dierdorf—Jonathan R. Hess, principal-in-charge, architecture; Daniel Alan Day, principal-in-charge, landscape design; Frederick Green, Gregg Clawson, project team

**Engineers:** Fink Roberts & Petrie (structural/civil); Syska & Hennessy (mechanical/electrical)

**Consultants:** Jules Fisher & Paul Marantz (lighting)

**General Contractor:** F. A. Wilhelm Construction



SECOND LEVEL

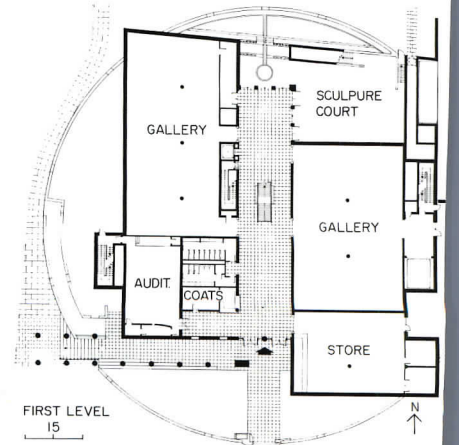

FIRST LEVEL

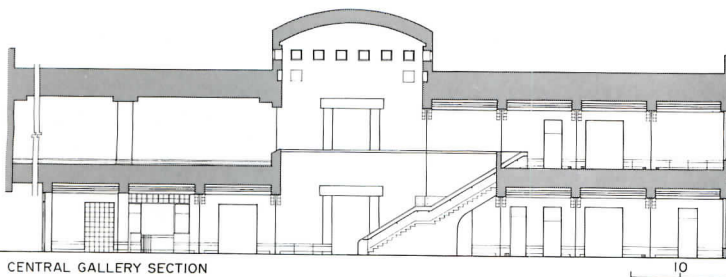

CENTRAL GALLERY SECTION







**ONLY ONE  
WINDOW COMPANY  
DARED TO TAKE  
ON THIS CITY HALL.**





# EXPERT TELLS HOW TO BEAT RECESSION: TRY NOTHING

© 1991 Konica Business Machines U.S.A., Inc.

*Level of  
interest hits  
zero*



**"NOTHING  
REALLY  
MOTIVATES  
SOME PEOPLE"**

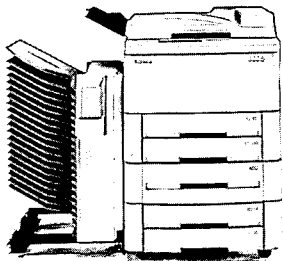

Some businesspeople are trying anything to beat the recession. Smart businesspeople are trying nothing.

Right now, when you buy any Konica copier or fax, you'll pay nothing in interest or finance charges.

It's smart business.

For more information on the  
Konica Interest-Free Program, call **1-800-648-7130**

Limited time offer.

Circle 18 on inquiry card

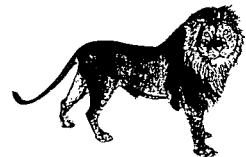

**Konica**  
COPIERS • FAX



For more information, circle item numbers on Reader Service Cards.

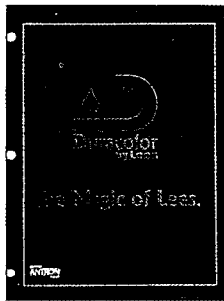

**Stain-resistant**  
Duracolor, a new dyeing process, produces commercial carpet with long-term resistance to common workplace stains such as coffee and soft drinks. Demonstration kit available. Lees Commercial Carpets.  
**400**

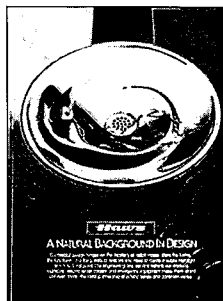

**Water Fountains**  
1991 catalog shows coolers designed for prominent spaces in offices and hotels, as well as units for healthcare and other institutions, finished in polished metals and colorful enamels. Haws Drinking Faucet Co.  
**401**

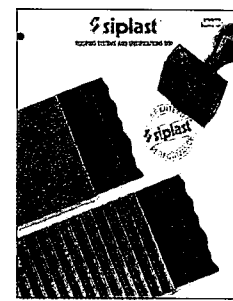

**Mod Bit Roofing**  
A 24-page architectural catalog recommends installation details, maximum slope, and deck construction for modified bitumen roofing systems, including Veral metal-faced products. Siplast.  
**402**



**Fire-resistant Sheathing**  
New Blazeguard panels, structural wood sheets laminated with an inorganic fire-shield center layer, have the same strength-to-weight ratio as untreated wood. Weyerhaeuser.  
**403**



**Steel-joint Construction**  
Color photos illustrate the economic, design, tensile, and floor-span advantages of steel-joint construction in projects that range from high-rise buildings to open-air pavilions. Vulcraft.  
**404**



**Railing Systems**  
Balustrade and handrails of metal and glass meet a number of design code, and functional requirements. Brochure includes support details and application photography. ACI Glass Products.  
**405**

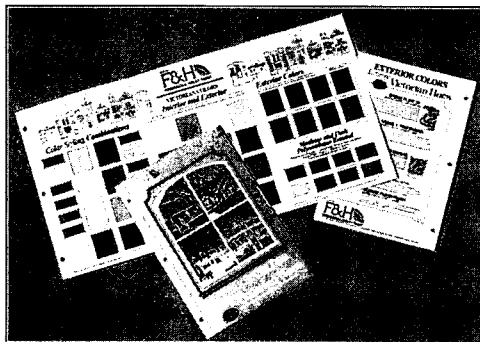

**Paint Selection**  
A color card samples 16 hues popular on the inside and outside of Victorian-era houses. Authentic trim colors, e.g., deep green, red, blue, and brown, are included. A styling panel suggests three appropriate color combinations. Paints

come in both acrylic and alkyd formulations for interior and exterior. Finnaren & Haley Paint.  
**406**

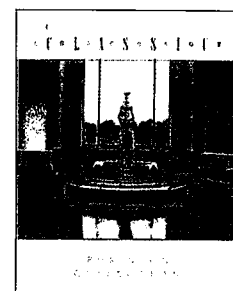

**Decorative Ironwork**  
Contains 16 color pages illustrating cast- and wrought-iron furniture, planters, torchères and custom architectural elements in a number of styles and finish options. Robinson Iron.  
**407**

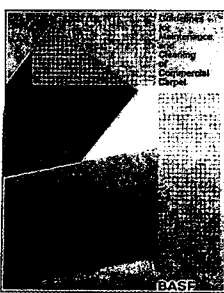

**Carpet Care**  
Guide stresses planning for maintenance during the carpet specification process, selecting the proper color, pattern, style, and location. Cleaning and restoration techniques illustrated. BASF.  
**408**

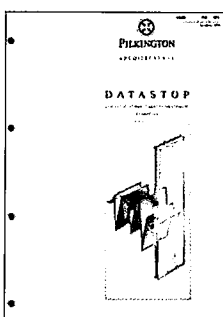

**EMI-Shielding Glass**  
Datastop is a visually clear coated glass developed by Pilkington that provides undetectable EMI protection as well as thermal and solar control properties. Tempest Security Screening.  
**409**

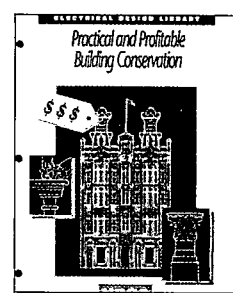

**Building Modernization**  
One of a series, monograph discusses ways to new hvac, light elevators, and electrical services unobtrusively in historical buildings. National Electrical Contractors Association.  
**410**



# Don't Invest In Any Curtain Wall Until You've Studied All The Angles.

Your curtain wall is your biggest visible expense. Don't base your selection on face value alone. Before you choose, ask yourself these important questions:



## 1 How reliable is the distributor/installer?

You could go with one of those new curtain walls, and find that nobody knows how to install it. Or choose Alucobond® material and get 12 years of installation experience, plus authorized distributors who'll get your materials on site, on time, even with short lead times. And you can depend on our distributors to keep your fabrication and installation on schedule.

## 2 What kind of quality am I getting?

Can your curtain wall resist buckling, rippling and oil-canning?

Alucobond material will. Made of two light-weight sheets of aluminum with a thermoplastic core, its impressive strength-to-weight ratio guarantees flatness, while conforming beautifully to curves and folds.



## 3 What about fire safety standards?

With Alucobond material and

Alucobond 21®, you're covered to meet the standards of BOCA, ICBO, SBCCI, New York City and Los Angeles, just to name a few.

**4 Can I afford it?** Compare costs, and you'll find that Alucobond material is an affordable alternative to brick, marble, granite, or pre-cast materials.

Any other questions? Let Alucobond's team of technical experts demonstrate the service that makes Alucobond material your best curtain wall value.

Just call us at 1-800-626-3365. We'll show you the smartest way to cover all the angles.

*Empire Bank, Springfield, MO  
Distributor: Midwest Metal  
Fabricators, Inc.  
New Haven, MO*

# ALUCOBOND®

MATERIAL



Alucobond Technologies, Incorporated

P. O. Box 507, Symsonia Road, Benton, Kentucky 42025 • 800-626-3365 • (502) 527-1376

Circle 19 on inquiry card



*New Diffussions™  
and Grid  
Diffussions  
Planks feature  
contemporary  
abstract patterns  
with a smart  
difference. They  
always arrive on  
time.*

THE

Circle 20 on inquiry card

## Product Literature

*Continued from page 116*



### Color Trends

A 30-page brochure introduces DuPont's 1992 Interior Color and Design Trends styling guide, with sections on fiber information and color theory. Thirty colors in four palettes are featured. Du Pont.

**411**



### Cabinet Hardware

Catalogs on Strothmann Design Plus hardware feature contemporary-style pulls and knobs in wood, solid-surface material, and chromed steel and other metals.

Hettich America.

**412**



### Roof Handbook

Mailer describes the 480-page 1991 Roofing Materials Guide, which permits side-by-side technical comparison of all commercial roofing membranes, metal systems, and insulations. National Roofing Contractors.

**413**

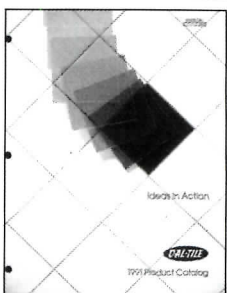

### Tile Selection

Full line of architectural and decorative ceramics is illustrated in a 60-page color catalog. Natural- and composite-stone tiles, setting materials, and design services are included. Dal-Tile.

**414**

*New prefinished  
Formal Woodgrain  
Planks use a  
stunning high-  
fidelity process to  
bring out the rich-  
ness of darker  
woodgrains. And  
they go up fast.*

SMART

Circle 21 on inquiry card



## Product Literature

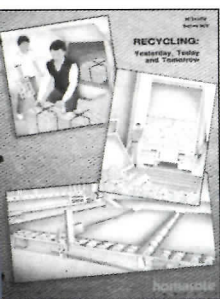

### Fiberboard Sheets

Underlayments, structural boards and decks, and composite stress-skin and fire-retardant panels made primarily of recycled newsprint are covered in an 8-page technical brochure. Homasote.

415

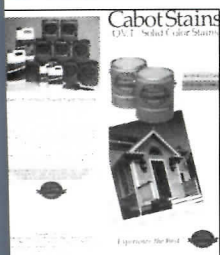

### Solid-color Stains

Color chart features 30 shades of O. V. T. acrylic- and oil-based wood coatings said to cover like paint and perform like stain. Can be used on new and previously coated surfaces. Samuel Cabot, Inc.

416

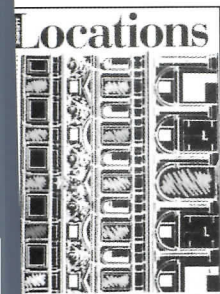

### Contract Carpet

On-site photography illustrates the performance and appearance of nylon carpeting in healthcare, office, school, and hospitality settings. Dorsett Carpet Mills.

417

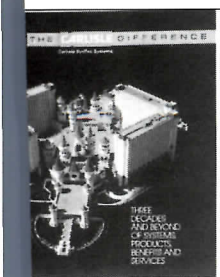

### Single-ply Roofing

Capabilities brochure highlights elastomeric materials and accessories, and discusses the firm's commitment to research and technical assistance for the architect and specifier. Carlisle SynTec Systems.

418

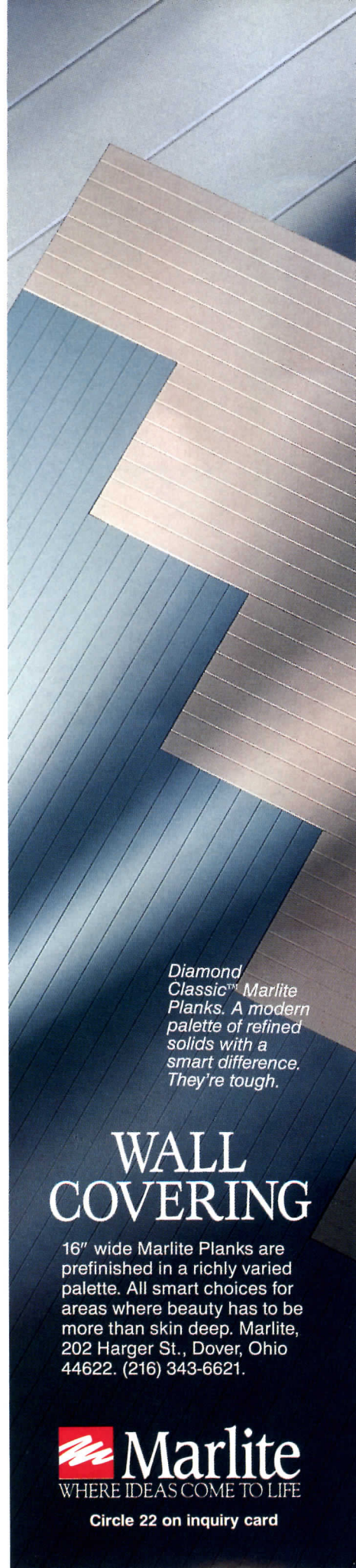

*Diamond Classic™ Marlite Planks. A modern palette of refined solids with a smart difference. They're tough.*

## WALL COVERING

16" wide Marlite Planks are prefinished in a richly varied palette. All smart choices for areas where beauty has to be more than skin deep. Marlite, 202 Harger St., Dover, Ohio 44622. (216) 343-6621.

 **Marlite**  
WHERE IDEAS COME TO LIFE

Circle 22 on inquiry card

## Product Literature

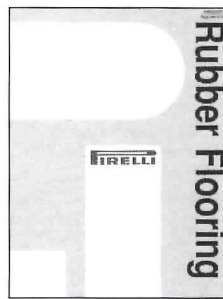

### Rubber Flooring

Colorful design catalog contains close-up photos of studded, smooth, and mat products, stressing rubber's special usefulness in high-traffic applications. Technical data are listed. Pirelli.

419

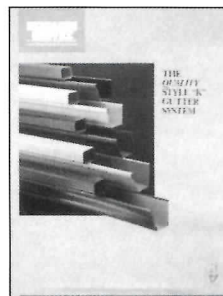

### Leaders and Gutters

Rain-carrying systems, offered in both "K" and half-round shapes, come in six colors, including dark and light bronze, as well as copper and galvanized metals.

Benjamin Obdyke.

420



### Cement Design

A free, well-indexed catalog describes over 500 publications, computer software, video-cassettes, and other materials available to design and construction professionals.

Portland Cement Assn.

421

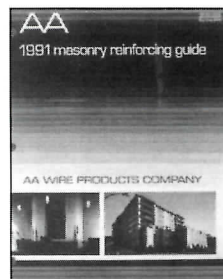

### Masonry Reinforcement

Over 60 types of masonry wall ties, reinforcing systems, and accessories featured in a 16-page catalog, including those that meet new ACI-ASCE 53011 standards. AA Wire Products Co. ■

422





# Sunbrella® Gets Put Up In All The Best Places.

From grand hotels to office buildings to shopping to restaurants, most any building can accommodate Sunbrella acrylic canvas or Sunbrella Firesist® canvas. Sunbrella Firesist meets the specifications of the National Fire Protection Association and the California Fire Marshal's test.

Both fabrics are ideally suited for customized graphics, backlit or not. And indoors or out, our fabrics are perfect for everything from awnings to canopies to privacy screens to cabana covers, and we always have a design to suit. Sunbrella is available in 90 handsome solids, stripes and patterns—more than any other acrylic—and Sunbrella Firesist is available in 23 styles.





**317. Fire-rated assemblies.** FR-Quik Channel Sets permit the use of structural wood trusses and I-beams in insulated floor and roof systems in occupancies that require two-hour ratings. Acting as an edge block, the channels maintain the integrity of gypsum panels during fire exposure. Lumbermate, Alpine Engineered Products.



**318. Fog effects.** The Mee system pressurizes tap water and atomizes it into a cloud-like mist. Described as energy-efficient, installations use very little water while creating unique microclimates for zoo exhibits and botanical gardens, special fountain like landscape displays (pictured), and evaporative air conditioning that cools people in outdoor parks. Mee Industries, Inc.



**319. Clear security grille.** For openings up to 45 ft wide and over 14 ft high, Vistaguard panel grilles allow full visual access while providing a solid security barrier. Lexan panels with aluminum rods form an almost airtight construction so grilles can separate air-conditioned spaces in retail malls. Cornell Works, Inc.

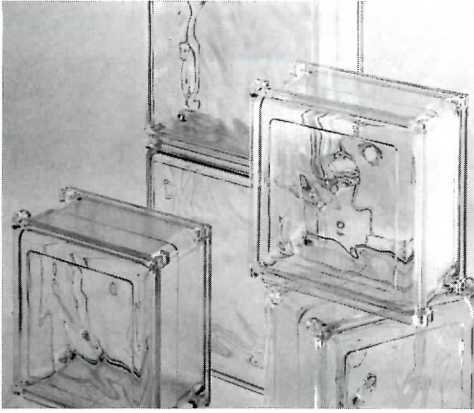

**320. Acrylic block.** Interlocking Plexiglas blocks have the appearance of glass units, but weigh only a fifth as much, with good acoustic and thermal-conductive values. Treated as an approved light-transmitting plastic under building codes, block panels can be installed as an interior partition or as part of an exterior wall. Blocks butt tightly together without mortar; latex caulking is needed only where required as an installation-specific air or moisture barrier. Color range includes clear, peach, rose, blue, and green. Hy-Lite Acrylic Block. ■



**According to Rick, it's a jungle out there.**

Especially for a veneer buyer. It's a jungle of undefined customer expectations. It's wading through a forest of subtle performance features of a variety of wood species. It's searching out the source and choosing just the right log for the job. It's knowing just how to bring out the innate beauty of each wood species.

"It requires a lot of exploration," says Rick Philipps, Director of Purchasing at Eggers. "I have to determine exactly what the customer has in mind as to product appearance. I call it 60 questions. Of course you have to know what questions to ask. In the 14 years I've been at Eggers, I've been lucky enough to have some of the old craftsmen pass on a lot of their knowledge to me.

Our people know how workable a particular species is and how to bring out the best appearance. I guess you could say that consultation is a big part of our job.

"After that, it's a matter of knowing where to find the most desirable flitch or log. It may involve as many as 15 to 20 suppliers. We have a good relationship with our suppliers. It pays off when we're looking for just the right log.

"We're usually pretty successful in giving the customer just what he wants."

**Eggers has a booklet of tips on working with and specifying veneer. Call (414) 793-1351 or write for it.**

"The next step is to see if the customer's expectations can be accomplished within the limitations of a particular species.

Circle 25 on inquiry card



**Eggers Industries**  
1819 East River St., P.O. Box 88, Two Rivers, WI 54241-0088



# Our Versatec plotters are years ahead of the competition.

They always have been.

And now our plotters offer another unmatched feature: the Xerox Total Satisfaction Guarantee. It guarantees your complete satisfaction for three years — three times longer than any other manufacturer. And only you decide when you're satisfied.

That's how confident we are about our entire line of plotters, including Turbo CADmate™, our affordable, high performance wide-format electrostatic plotter; the 8900 Series high performance electrostatic color plotter featuring unattended operation; and the 8836 II Laser, the industry's most popular wide-format plain paper plotter.

All Versatec plotters are covered by this exclusive guarantee. There are no catches. No fine print.

Here it is in plain English:

*"If you are not satisfied with your Xerox equipment, at your request, Xerox will replace it without charge to you with an identical model or a machine with comparable features and capabilities.*

*"This Xerox Total Satisfaction Guarantee applies to Xerox equipment acquired by you from Xerox and continuously maintained by Xerox or its authorized representatives under our Manufacturer's Warranty or a Service Contract."*

See us at AEC Systems May 8-10, Booth 711

Now that's simply the best warranty you can get. No ifs, ands or buts about it. After all, you'd expect nothing less from Xerox Engineering Systems. The world's largest supplier of engineering copiers, Versatec printers and plotters.

So, for more information, call us at 800-538-6477.

In California, 800-341-6060. Or go ahead and buy your Versatec plotter today. You'll still have a few years to think it over.

## **Xerox Engineering Systems**

2710 Walsh Ave., Santa Clara, CA 95051  
Xerox is a trademark of Xerox Corporation. Versatec and Turbo CADmate are trademarks of Versatec, Inc.

Circle 26 on inquiry card

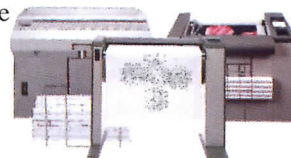



**Update** *Continued from page 39*

the newly created State Revolving Funds, which have yet to realize their potential as a substitute for EPA construction grants. With 1991 contracting for transportation construction on the rise, but environmental work slipping, total public-works contract value is headed toward \$45 billion, exactly where it was in 1990 and 1989—and just incidentally, the biggest number on record.

Like public-works construction, institutional building (schools, healthcare facilities, public administration buildings, etc.) is capable of matching 1990's record contract value in 1991, but isn't likely to exceed it. A full decade of uninterrupted expansion has managed to keep pace with the supportive demographics of this building market, which responds to what is going on at the ends of the population spectrum (0 to 15; 65 and over) where growth is exceeded only by the now middle-aged '50s generation.

Most institutional building is state-sponsored and, with recession currently pinching state budgets (40 are showing deficits this year), a temporary deferral of some less urgent building seems inevitable. Once the economy recovers, however, tax revenues will increase and unemployment benefits will shrink. As this happens, the growth trend of institutional building that led to a doubling of annual contract value over the past decade is bound to re-emerge. In 1991, meanwhile, institutional building is one of the few remaining pockets of support in a generally depressed construction market.

Stability of institutional building and strength in highway construction will partially offset the continuing decline of housing and commercial building this year, but that's as much as they are capable of doing. Total construction-contract value, now forecast at \$231.9 billion, will slip another percent in 1991 as the conditions that triggered last year's 11 percent decline gradually relent.

Regional differences in 1991 are not expected to be as pronounced as they were in 1990 when the nation's coastal areas bore the brunt of the downturn. The Northeast, which led the nation into decline, virtually collapsed in 1990 when contracting fell 20 percent. The risk of further setback from the currently depressed level of building is small. The South Atlantic and the West, where cyclical downturns occurred later than that of the Northeast, are still adjust-

ing to changed market conditions and will be the regions with above-average declines in 1991. The North Central, which was a late participant in the 1980s building boom, is, as a consequence, least over-extended. This region will be showing only a small decline in 1991, as it did last year.

The South Central has been going the wrong way for the past half-dozen years, but finally offers an opportunity for modest improvement. This region is a special case in which local market conditions outweigh general economic and financial considerations.

**Leaving the '80s behind**

The collapse of the 1980s building boom in 1990/91 might be thought of as a delayed reaction to a combination of extraordinary events. Abuses of the opportunity for accelerated depreciation of commercial buildings, coincident with the deregulation of the thrift industry (and its eventual self-destruction), explain a lot of what went wrong in the "Avaricious Eighties." The coming recovery of construction will follow a more traditional pattern even as it is conditioned by a few unique circumstances of the "Back-to-Normal Nineties." More about that later. ■

© 1990 Raynor Garage Doors



**6** years, 36 months of darkness,  
45 snowstorms, 500 inches of snow,  
92,000 cups of coffee (24,000 creams),  
two polar bears,  
one Raynor™ Tri-Core™ Door,  
one Raynor Distributor.

**RAYNOR GARAGE DOORS**

You can't imagine what a garage door goes through over the years. But you don't have to when you specify a Raynor Tri-Core Door, because the only thing more reliable than a Raynor Door is a Raynor Distributor. To locate the one nearest you, call 1-800-545-0455.

**Circle 27 on inquiry card**



# Custom Built Site Furnishings

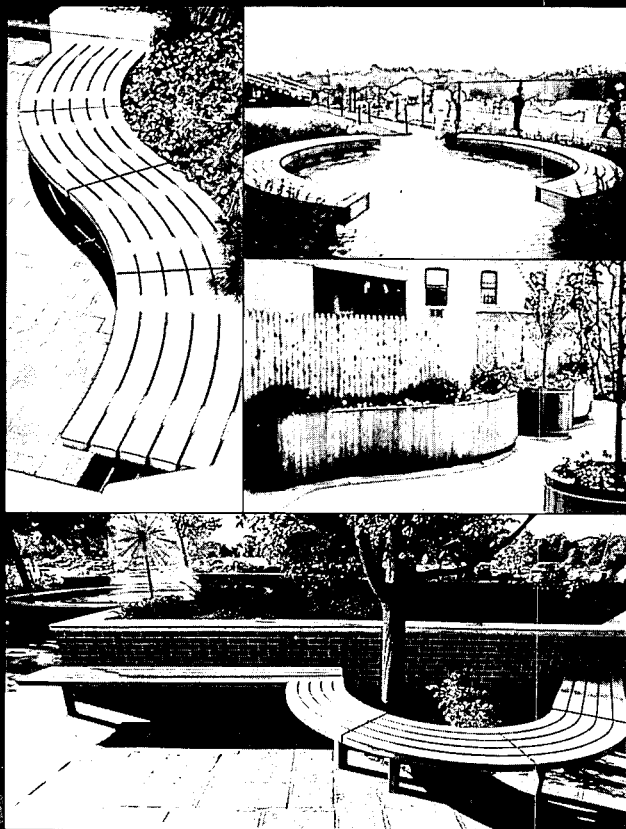

## One-of-a-kind problem solvers.

Sitecraft brings your most creative ideas to life. We work with you at every step and offer the custom expertise and experience that other site furnishings manufacturers just can't match. Sitecraft benches, planters, planter benches and site accents are available in clear, all heart California redwood or other choice woods. Even the most demanding custom configuration can be created to your exact specifications.

One-of-a-kind site furnishings solutions are not a problem when you call Sitecraft.

For information on the complete line of Sitecraft site furnishings send for your **FREE SITECRAFT IDEA BOOK** today.

Want to discuss a particular custom design idea and how Sitecraft can help? Easy, just **FAX your sketch or concept to us at 718-482-0661**

or call Toll Free 800-221-1448.

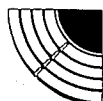

# sitecraft

40-25 Crescent St., Long Island City, NY 11101

# PRESERVATION PLAN ON IT

Planning on restoring a house, saving a landmark, reviving your neighborhood?

No matter what your plans, gain a wealth of experience and help preserve our historic and architectural heritage. Join the National Trust for Historic Preservation and support preservation efforts in your community.

Make preservation a blueprint for the future.

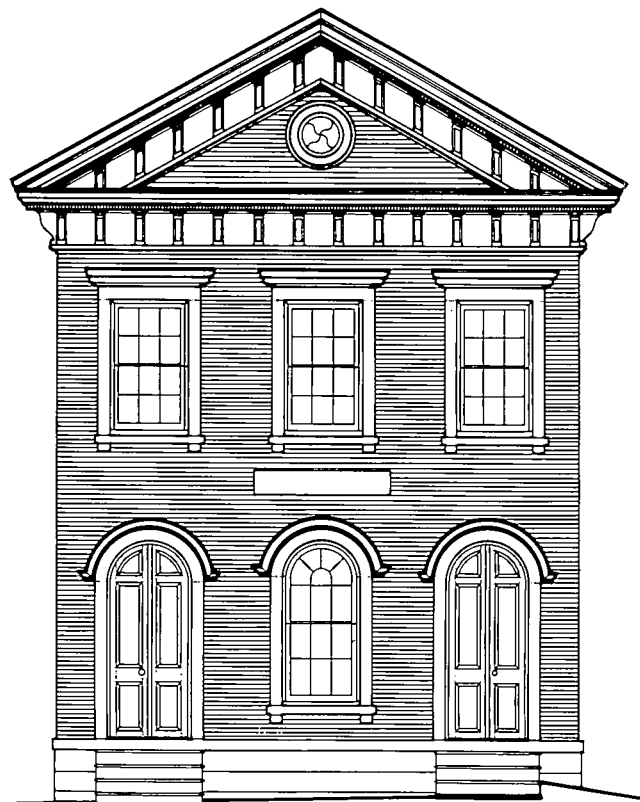

SOUTHPORT SAVINGS BANK, SOUTHPORT, CT.



Write:

**National Trust for Historic Preservation  
Department PA  
1785 Massachusetts Ave., N.W.  
Washington, D.C. 20036**

Circle 28 on inquiry card



# THE CHOICE.



A wide choice of edge details to create a decorative ceiling of subtle elegance. For a detailed brochure write The Celotex Corporation, Attention: Cashmere, Box 31602, Tampa, FL 33631. FAX: 1-813-873-4103.

**Celotex**

*Cashmere*

THE CHOICE IN FINER CEILINGS

Circle 32 on inquiry card



## Manufacturer Sources

For your convenience in locating building materials and other products shown in this month's feature articles, *RECORD* has asked the architects to identify the products specified.

### Pages 66-73

1150 Eighteenth Street N.W.  
Hisaka and Associates, Architect  
Insulated painted-metal panels: Leed Himmel Industries. Curtain wall system and windows: Crown Aluminum & Glass. Glass: J.E. Berkowitz. Precast panels: Olds Cast Stone. Perforated

metal: McNichols. Entrance: Brite Vue. Pivot hinges: Rixson. Door pulls: Blumcraft of Pittsburgh. Flagpoles: Baartol Co. Skylight: American Iron Works; Falconer Glass. Atrium light fixtures: Poulsen Lighting. Paint on metal surfaces: Pratt & Lambert. Wall paint: Benjamin Moore; Pratt & Lambert. Granite: New England Stone (Silver Cloud).

### Pages 78, 80-83

Clinical Research Building  
Payette Associates, Inc., Architects  
Venturi Scott Brown Associates, Associated Architects  
Brick: Yankee Hill; Endicott Clay Products. Cast stone: Russell Cast Stone. Curtain wall: Butler

Mfg. Single-ply roofing: Carlisle Syn-Tec System. Steel-framed windows: Marmet. Window blinds: Levelor. Wood entrance and interior doors: Weyerhaeuser. Ceiling tile and resilient flooring: Armstrong. Integrated ceiling: Simplex Ceiling. Paneling and wainscot: Haggerty Millwork. Laminates: Wilsonart. Lounge seating: Hitchcock. Cafeteria lighting: Columbia. Quarry tile: American Olean. Chandelier: Sterling (custom). Laboratory light fixtures: Peerless Lighting.

### Pages 79, 84-87

Thayer School of Engineering  
Venturi Scott Brown Associates, Architects  
Payette Associates, Inc., Associated Architects  
Brick: Morin. Granite: Rock of Ages. Roofing: Firestone; copper. Wood-framed windows, stile-and-rail doors, and custom casework: Sanborn Wood Products. Aluminum-framed windows: EFCO. Locksets, closers, and exits: Corbin. Hinges: Stanley. Exterior lighting: Gardco.  
**Page 87**—Vaulted ceiling: Armstrong (custom suspended system). Paints: DeVoe & Raynolds. Clock case: Electric Time. Chairs: Hitchcock. Lighting: Columbia; Kurt Versen.

### Pages 88-95

Dana-Thomas House  
Hasbrouck Peterson Associates, Restoration Architects  
Replica clay-tile roofing: Van de Hey-Raleigh. Underlayment: W.R. Grace. Wood windows, doors, and custom woodwork: Stott Millwork. Exterior lights: Lumark. Art glass restoration: Melotte-Morse. Coach House skylights: EPI Architectural Systems. Exterior concrete treatment: ProSoCo. Exit signs: Isolite. Fire sprinklers: Reliable. Wood stain: Red Devil. Floor finish: Sherwin-Williams. Plaster glaze: Mantrose Hauser. Period fixtures: Milwaukee Brass Light Gallery. Handicap stair-lift: Garaventa.

### Pages 96-103

The CambridgeSide Galleria  
Arrowstreet, Inc., Architects  
Banners and graphics: Fitch Richardson Smith; Clifford Selbert Design. Waterstruck brick: Kane Gonic. Cast stone: W.N. Russell. Granite: New England Cut Stone. Storefronts and entrances: Kawneer. Low-E glass: Viracon. Locksets, closers, and exits: Sargent. Skylight system: Fisher. Reflective glass: PPG. Single-ply roofing: Carlisle Syn-Tec. Batten-seam metal roof: AEP Span. Benches: Columbia Cascade. Incandescent lighting: Lightolier. Neon and special lighting: Demco.  
**Pages 102-103**—Metal ceiling: Simplex. Tile: Flandre. Chairs: Hauser. Cafe tables: Johnson. Escalator: Montgomery.

### Pages 104-109

Eiteljorg Museum of American Indian and Western Art  
Browning Day Mullins Dierdorf, Inc., Architect  
Dolomite: Vetter Stone. Red sandstone: Carl Schilling Stone Works. Teak siding, entrance, and woodwork: Southeastern Supply. EPDM roofing: Firestone Building Products. Flat-seamed metal roof: copper. Teak and mahogany windows: Duratherm. Glazing: Viracon. Metal and interior windows: Steelcraft. Exterior lighting: Winona.  
**Pages 108-109**—Veneer and acoustic plaster: U.S. Gypsum. Ceiling tile: Armstrong. Grid: Chicago Metallic. Paints: DeVoe & Raynolds. Wood-floor treatment: DuraSeal. Exhibit and general lighting: Edison-Price.



CENTRAL ARTERY (I-93)/TUNNEL (I-90) PROJECT  
BOSTON, MASSACHUSETTS

## ANNOUNCEMENT OF A DESIGN BRIEFING

THE MASSACHUSETTS DEPARTMENT OF PUBLIC WORKS INVITES INTERESTED DESIGN CONSULTANTS TO AN INFORMATION UPDATE ON FUTURE SECTION DESIGN CONTRACTS:

- SCHEDULE OF UPCOMING SOLICITATIONS
- REPACKAGING FOR MORE CONTRACTS

DESIGN PROFESSIONALS — ENGINEERS, ARCHITECTS, LANDSCAPE ARCHITECTS, AND URBAN DESIGNERS — ARE ENCOURAGED TO ATTEND. DISADVANTAGED BUSINESS ENTERPRISES ARE PARTICULARLY ENCOURAGED TO ATTEND.

FRIDAY, MAY 17, 1991  
9:00 A.M. - 12:30 P.M.  
FEDERAL RESERVE BANK AUDITORIUM  
GROUND FLOOR  
600 ATLANTIC AVENUE  
BOSTON, MASSACHUSETTS

ATTENDANCE WILL BE LIMITED TO A MAXIMUM OF ONE PERSON PER ORGANIZATION DUE TO SPACE AVAILABILITY. RESERVATIONS AND INFORMATION CAN BE OBTAINED BY CALLING (617) 951-6187, PRIOR TO MAY 10, 1991.

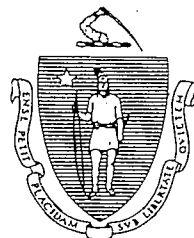

COMMONWEALTH  
OF MASSACHUSETTS

DEPARTMENT OF PUBLIC WORKS

CENTRAL ARTERY/  
TUNNEL PROJECT  
ONE SOUTH STATION  
BOSTON, MA 02110