

JANUARY 1954

ARCHITECTURAL RECORD

BUILDING TYPES STUDY NUMBER **206**



SOCIAL AND RECREATIONAL BUILDINGS



Research Laboratory Classroom, Daylighting Laboratory, University of Michigan

America's most advanced schoolroom

The "Classroom of Tomorrow" has been built in the Daylighting Laboratory at the University of Michigan to demonstrate the new flexibility now possible in interior design—choice of materials, color and equipment without loss of high-quality daylighting which is so important to the education, the health and general well-being of the school child.

Twelve years of daylight research at the Engineering Research Institute, University of Michigan, has made possible this "Classroom of Tomorrow."

New freedom in the planning of classrooms is made possible by the proper application of two Engineering Research Institute developments—modern Light-Directing Glass Block for use in side walls and Light-

Selective Toplite Panels for use in roofs.

The ideas perfected in this Research Laboratory Classroom are available to you now. Write for details and see how these Owens-Illinois products can produce a better learning environment in your schoolrooms. Address: Classroom Research, Owens-Illinois Glass Company, Dept. AR-1, Box 1035, Toledo 1, Ohio.

GLASS BLOCK AND TOPLITE PANELS
TWO **Ⓡ** PRODUCTS

OWENS-ILLINOIS
GENERAL OFFICES • TOLEDO 1, OHIO

ARCHITECTURAL RECORD

January 1954 Vol. 115 No. 1

Copyright 1954 by F. W. Dodge Corporation, with all rights reserved. ARCHITECTURAL RECORD (combined with AMERICAN ARCHITECT and ARCHITECTURE) is published monthly by F. W. Dodge Corporation, 10 Ferry Street, Concord, New Hampshire, with editorial and executive offices at 119 West 40th Street, New York 18, New York. Western editorial office, 2877 Shasta Road, Berkeley 8, California.

STAFF OF ARCHITECTURAL RECORD

 **H. Judd Payne**, *Publishing Director*; **Robert F. Marshall**, *General Manager*; **Marshall T. Ginn**, *Circulation Manager*. . . **Joseph B. Mason**, *Executive Editor*; **Emerson Goble**, *Managing Editor*; **James S. Hornbeck**, A.I.A., **Frank G. Lopez**, A.I.A., *Senior Associate Editors*; **Elisabeth Kendall Thompson**, *Associate Editor and Western Section Editor (Berkeley, California Office)*; **Robert E. Fischer** (*Engineering*), **Florence A. van Wyck**, **Herbert L. Smith, Jr.**, A.I.A., **Jeanne M. Davern** (*News*): *Associate Editors*; **Ernest Mickel**, **Dan Street** (*Washington*), **John Caulfield Smith**, M.R.A.I.C. (*Canada*): *Contributing Editors*; **Marjorie Blake**, **Grace M. Anderson**: *Editorial Assistants*; **Peter Piening**, *Consulting Design Director*; **Eugene H. Hawley**, **Alfred Petersen**: *Design*; **Sigman-Ward**, *Drafting Consultants*; **Thomas S. Holden**, *Industry Relations Consultant*; **Clyde Shute**, *Statistical Consultant*; **Clifford Dunnells, Jr.**, *Field Research Consultant*; **Samuel C. Pace**, *Public Relations Consultant*.

TABLE OF CONTENTS

The Record Reports

Perspectives	9
Opinion	24
News From Canada. By John Caulfield Smith	26
News From Washington. By Ernest Mickel	38
Construction Cost Index	42
Required Reading	46
Current Trends in Construction	278

Carnegie International Center

To express the dignity and human sympathy of organizations devoted to peace, with the utmost economy, was an assignment that forced the architects into some new ideas. Carnegie Endowment for International Peace, New York; Harrison & Abramovitz; Goldstone & Abbe, architects. 121

Architectural Interiors

Interior Design by a Consultant. Carnegie International Center. Knoll Associates Planning Unit, Interior Design Consultants 126

Forget the "International Style"

The State of Contemporary Architecture. I. The Regional Approach. By *Sigfried Giedion* 132

House With Multi-use Spaces

Residence of Norton Polivnick, Denver, Colo. Norton Polivnick, architect 138

Prize-Winning Design for State Office Building

Concord, N. H. Nichols & Butterfield, architects 142

Building Types Study Number 206 — Social and Recreational Buildings

Try Imagination: Don't Forget Diversion. By *John E. Burchard* 147
Park-School Cooperation Adds To Funds 150
L. Loyal Heights Fieldhouse, Seattle, Wash.; Naramore, Bain, Brady & Johanson, architects 150

ARCHITECTURAL RECORD

Continued from page 5

Building Types Study Number 206 — Social and Recreational Buildings (Continued)

Recreation Centers Keep the Kids Occupied	152
2. Thomas Jefferson Recreation Center, New York City; Edward D. Stone, architect	152
3. Recreation Center, Highland Park, Ill.; Bertram A. Weber, architect	153
4. Gentle Community Building, Houlton, Me.; Alonzo J. Harriman, Inc., architects and engineers	154
Playgrounds Have Discovered Design	155
5. Standard Oil Co. of Calif. Rod and Gun Club, Richmond, Calif.; Eckbo, Royston, and Williams, Landscape architects	155
6. Model for a Children's Playground; Isamu Noguchi and Julian Whittlesey, designers	157
Libraries Develop Their Social Sense	158
7. Manhasset Public Library, Manhasset, N. Y. Gibbons & Heidtmann, architects	158
8. Parkside Branch Library, San Francisco, Calif. Appleton & Wolfard, architects	160
Music Develops New Building Types	161
9. Triangle Building Bandroom, Punahou School, Honolulu, T. H.; Yoshio Kunimoto, structural engineer	161
New Town Plans Integrate Recreation	162
10. City Plan Projects for Latin America. Town Planning Associates: Paul Lester Wiener and José Luis Sert	162
Water Sports are Most Popular of All	164
11. Flynn Memorial Recreation Pavilion, Detroit, Mich. Swanson Associates, architects	164
12. Shorehaven Beach Club, Bronx, N. Y.; O'Hara, Hedlander and Edson, architects	164
13. Skating Shelter, Hubbard Woods Station Park, Winnetka, Ill.; Howard T. Fisher & Assoc., Inc., architects	165
14. Public Beach Resort, Linda Isle, Newport Harbor, Calif. Welton & Becket & Associates, architects	165
Museums, Too, Try New Trends	166
15. Metropolitan Museum of Art, New York, N. Y.	166
16. Museum of Art of Ogunquit, Ogunquit, Me.; Charles Worley, Jr., architect	167
17. Art Gallery, Design Center, Yale University, New Haven, Conn.; Louis I. Kahn, architect	167
Theaters Fight TV With New Appeals	168
18. Paramount Preview Theater, New York, N. Y. Reisner & Urban, architects	168

Architectural Engineering

Structural Analogies Taken From Nature	
The Structures That House Us. By Fred N. Severud	169
Prefabrication Cuts School Costs	
Tip-Up Steel Frames Form Classroom Walls. Senior High School, Moultrie, Ga.	175
Product Reports	176
Office Literature	178
Time Saver Standards	181

Index to Advertising

280

OFFICERS OF THE F. W. DODGE CORPORATION

James McV. Breed, Chairman of the Board; **Paul Abbott** and **Thomas S. Holden**: Vice Chairmen of the Board; **Howard Barringer**, President; **Irving W. Hadsell**, **Chauncey L. Williams**: Executive Vice Presidents; **Howard M. Thompson**, Vice President and Treasurer; **Julius T. Little**, **Robert F. Marshall**, **T. Oliver Morgan**, **H. Judd Payne**: Vice Presidents; **Carl S. Bennett**, **Ralph M. Hairston**, **O. O. Paulsell**, **Richard H. Ray**: Regional Vice Presidents; **Edwin H. Freed**, Assistant Vice President and Comptroller; **Walter F. DeSaix**, **Clifford G. Dannels, Jr.**, **Clyde Shute**, **Marc Wayne**: Assistant Vice Presidents; **Sanford D. Stockton, Jr.**, Secretary; **William C. Breed, Jr.**, **George W. Morgan, Jr.**: Assistant Secretaries; **Irving B. Satin**, Assistant Treasurer.

OTHER F. W. DODGE SERVICES:

Dodge Reports and Dodge Statistical Research Service — Sweet's Files — "Planning Kit for Our New Home" — Chicago Construction News — Daily Pacific Builder — Denver Daily Journal — Real Estate Record & Builders' Guide.

Member of Audit Bureau of Circulations and Associated Business Publications. Architectural Record is indexed in Readers' Guide to Periodical Literature, Art Index, Industrial Arts Index and Engineering Index.

Every effort will be made to return material submitted for possible publication (if accompanied by stamped, addressed envelope), but the editors and the corporation will not be responsible for loss or damage.



Subscription rates in U. S., U. S. Possessions, and Canada: \$5.50 for one year, \$9.00 for two years, \$11.00 for three years. Elsewhere, subscriptions from those who by title are architects or engineers, \$6.50 for one year, \$11.50 for two years, \$15.00 for three years; subscriptions from all others outside U. S., U. S. Possessions and Canada, \$20.00 a year. Single copy price, \$2.00. Circulation Manager: Marshall T. Ginn.



expanded living

relaxing living at a price
anyone can afford.

Write for our descriptive
literature on

Malibu Sliding Glass Doors.

MALIBU SLIDING GLASS DOORS

New lateral force design reference

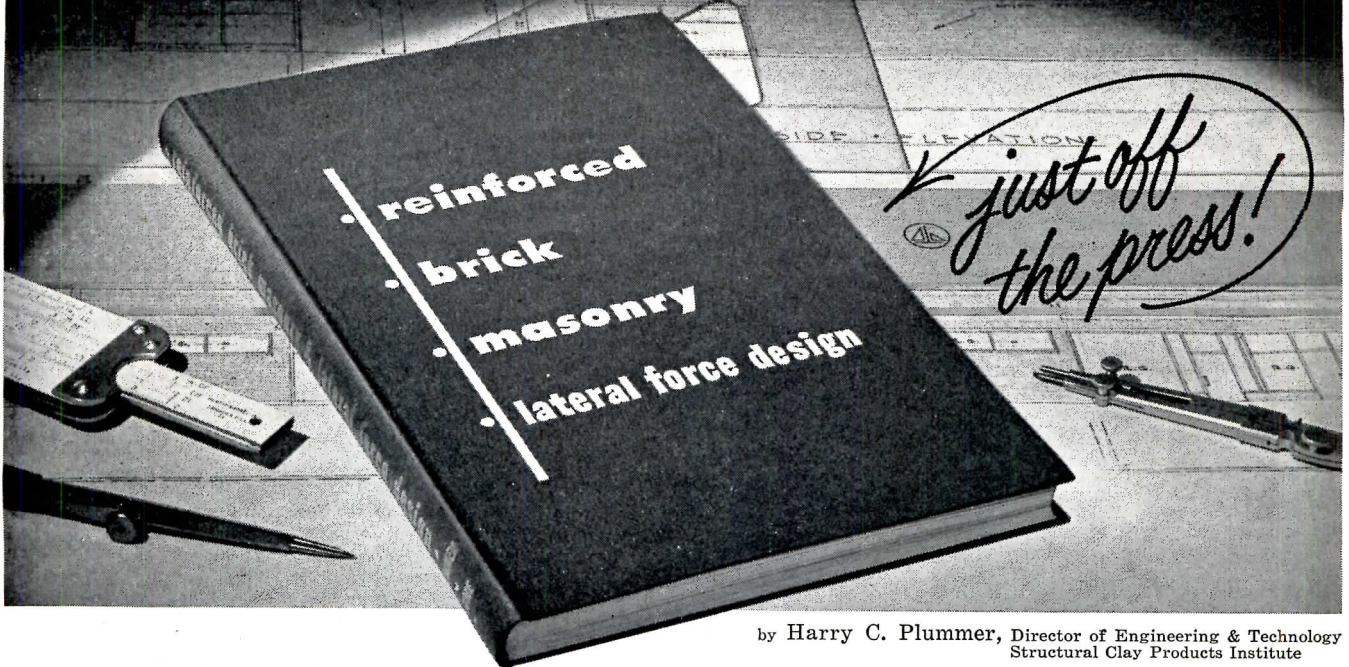

by Harry C. Plummer, Director of Engineering & Technology
Structural Clay Products Institute

and John A. Blume, Consulting Structural Engineer
San Francisco, California

Over 150 details,
tables and photographs

only \$4.95

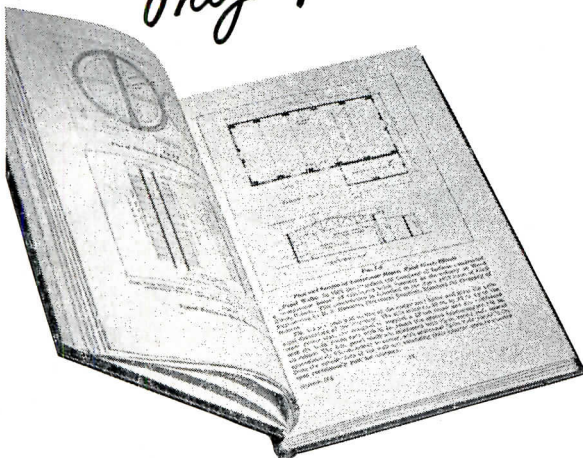

timely...
authoritative...

complete... This new textbook is written to meet the growing demand among architects and engineers for concise, authoritative information about structural systems which will resist tornadoes, earthquakes or bomb blast. (A recent survey shows that lateral force considerations are playing a more important role in the design of many structures.)

The book tells how to use Reinforced Brick Masonry (RBM) in lateral force design—thereby retaining the advantages of brick's wide color range, pleasing textural effects, permanence and freedom from maintenance. It contains scores of details of RBM construction in a wide variety of structures, comparative cost figures, data on the performance of both reinforced and unreinforced masonry, recommended design and construction procedures and a review of currently accepted design criteria.

SEND COUPON TODAY

Structural Clay Products Institute, Dept. AR-1
1520 18th Street, N. W.
Washington 6, D. C.

Please send me _____ copies of "Reinforced Brick Masonry and Lateral Force Design" at \$4.95 per copy. I enclose my check for \$_____

Name _____

Firm _____

Address _____

City _____ Zone _____ State _____



STRUCTURAL CLAY PRODUCTS INSTITUTE
1520 18th Street, N. W., Washington 6, D. C.

THE RECORD REPORTS

P E R S P E C T I V E S

WALTER GROPIUS goes to São Paulo this month to receive, at 70, the 1954 São Paulo Prize, the biennial award (worth about \$7800 at current exchange rates) of the Andrea and Virginia Matarazzo Fund of São Paulo. Francisco Matarazzo established the prize in 1951, when he learned that Nobel Prizes do not cover the field of architecture, "to crown the creative activities of an architect of any nationality whose work reveals international significance for the development of contemporary architecture." The jury of award included architects Alvar Aalto, Finland; Le Corbusier, France; Ernesto Rogers, Italy; Jose Luis Sert, U. S.; Alfonso Reidy and Gregory Warchavchik, Brazil; and — *ex officio* — the president of the Institute of Architects of Brazil; the president of the São Paulo Museum of Modern Art; and a member of the Matarazzo Foundation's council. The award ceremony will be part of the current Second Biennial of Modern Art and São Paulo's 400th anniversary celebration.

BEST YEARS OF YOUR LIFE? Well, according to Harvey C. Lehman's new book "Age and Achievement," peak productivity in architectural design is achieved at ages 40 to 44. Dr. Lehman concludes from an exhaustive statistical analysis — the book itself has 170 graphs and 61 tables — that in most of the arts and the sciences, the thirties are the most creative years; leadership peaks — in such fields as business, religion, and politics — appear much later — in the fifties, the sixties and even the seventies. In art, music and literature — the statistics say — the range of peak productivity is from 22 to 44, and to put an even finer point on it — symphonies 30 to 34; light opera and musical comedy 40 to 44; sonnets 26 to 31; short stories 30 to 34; novels 40 to 44; oil paintings 32 to 36.

WHAT THIS COUNTRY NEEDS, according to the president of the Westinghouse Electric Corporation, is for engineers to play a greater role in public life and take the lead in "applying engineering principles to our social problems." Gwilym A. Price, addressing the annual meeting of the American Society of Mechanical Engineers, deplored the engineer's tendency to stay clear of such commitments — none of the 48 governors is an engineer, he noted, and there are only two engineers in the U. S. Senate. Because he is everywhere respected for his character, competence and record, and is welcomed by all groups, the engineer, Mr. Price declared, might successfully "erect a bridge between the technical and the humanistic world, and bring diverse groups together into a common program as no one else is equally capable of doing."

AS FOR ARCHITECTS, they may wish to reflect on *their* function as "messengers of discontent," as suggested in a recent speech by George Howe, F.A.I.A., retiring chairman of Yale's Department of Architecture. Mr. Howe, who had been addressing himself to the proposition that economic analysis must not be allowed to establish the esthetic for urban design, quoted from Edgar Singer's essay "Esthetic and the Rational Ideal" the admonition that artists must be "messengers of discontent," for "only that art whose purpose is to change the purposes of the beings to whom it is addressed is fine art." The architect concerned with urban design today, said Mr. Howe, has great need of the virtues prescribed for the alchemist in the *Liber Perfecti Magisterii*: "He must have a subtle mind and possess sufficient knowledge of the metals and minerals. But he may not have a coarse and hard mind, nor may he be greedy and avaricious, undecided and vacillating: furthermore he may not be in a hurry

nor may he be conceited; on the contrary, he must be firmly resolved, tenacious, patient, mild, long-suffering and moderate." Even architects *not* concerned with urban design might want to paste that one up.

THE ARCHITECT AND THE ENGINEER got together to discuss the interrelationship of architecture and engineering in the third of the Architectural League of New York's current series of forums on "The Impact of Science and Materialism on the Arts Today." There were few surprises: the engineers wished that architects would be more "realistic" about technological problems and the architect insisted on the preeminence of the esthetic as the criterion of good architecture and as a catalyst for technological progress. They all agreed on the usefulness of broader dissemination among architects and engineers generally of the fruits of their experiences with new materials and new techniques — the failures as well as the successes. One suggestion: to establish a central clearinghouse of such information, financed with modest annual dues from all the (interested) architects and engineers in the country. Architect on the panel was Max Abramovitz of Harrison & Abramovitz; engineers were William Eipel of Eipel-Engineering and Alfred Jaros of Jaros, Baum & Bolles. Frank G. Lopez, a senior associate editor of ARCHITECTURAL RECORD, was the moderator.

13131313 — did he make the trip? As Hedrich-Blessing's Hedrich tells it, Architect Harold Spitznagle was not only willing but eager to travel on Friday the 13th if only he could get reservations on the Broadway Limited from Chicago to Philadelphia. He couldn't, and asked Hedrich to try for him. Hedrich found himself dealing with Reservation Clerk No. 13, who offered Roomette No. 13, which cost \$13.13. Well, would you?

THE RECORD REPORTS

Oberlin's new Sophronia Brooks Hall Auditorium, dedicated October 31, is \$1,281,000 dramatic arts center, designed to cope not only with plays, musical comedy, opera, motion pictures and the dance but with recitals, concerts, public lectures, debates, course lectures and classes as well. Left: serpentine front is white marble. Below: hard plaster walls were tilted and sloped for acoustical purposes. Architects—Harrison & Abramovitz; Eldredge Snyder, associate; Arvin Shaw III, project architect. Mechanical engineers—Jaros, Baum & Bolles. Acoustical engineers—Bolt, Beranek & Newman



TODAY'S BUILDINGS: A RANDOM GLANCE

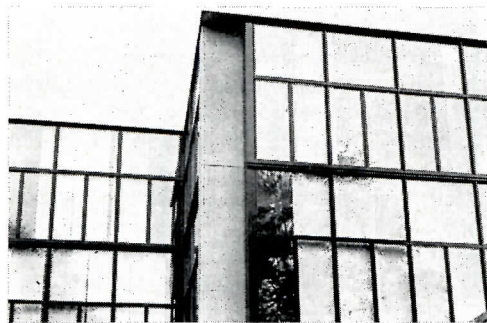

Yale's Art Gallery and Design Center, dedicated November 6, houses exhibits as well as classrooms and offices of art, architectural, city planning and graphic arts departments, is connected to old art gallery, with access on all four floors. One wall is gray-brown brick, two are glass, fourth is link with old building. Inside, all construction elements except flooring are left exposed and unpainted. Below: floor and ceiling construction is series of tetrahedrons about two ft deep designed to act as its own sound-proofing and conceal heating, air conditioning and lighting ducts; movable "pogo panels" for exhibits were originally conceived by George Howe, retiring chairman of Yale's Department of Architecture. Maximum flexibility was a major goal of planning. Architect: Louis Kahn, in association with the Office of Douglas Orr

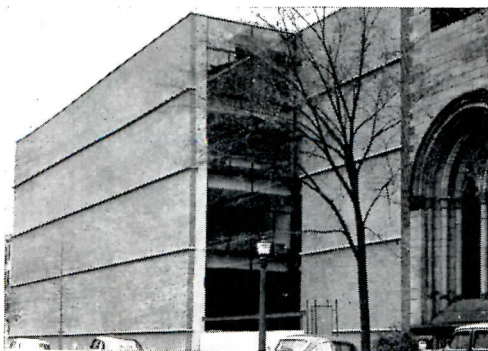

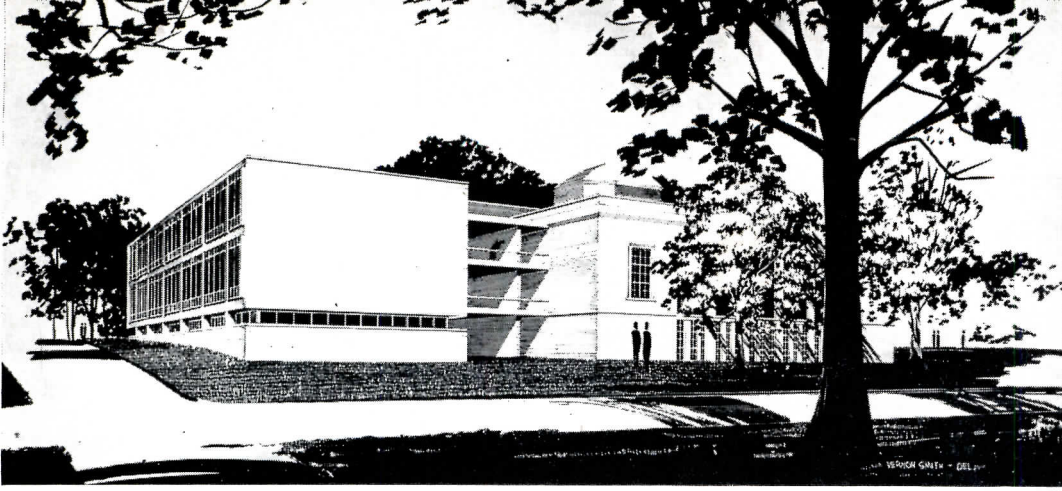

Interior modifications of an existing Georgian library by Hobart Upjohn and an addition (above) carefully designed with its attenuated connecting link not to disturb the symmetrical composition of the old building will provide a new headquarters for the North Carolina State College School of Design. Similar brick and marble for exteriors will also help to unite the old and the new. George Matsumoto is representing the School of Design and consulting with the architect, F. Carter Williams of Raleigh, where Macon Smith is in charge of the project

18-story 1001-room Dallas Statler, under way since October, will make full use of flat-slab cantilever construction. Exterior walls of aluminum and porcelain enamel will be prefabricated in sections to expedite construction. Cost is estimated at \$15 million. Architect: William B. Tabler



AROUND THE HORIZON

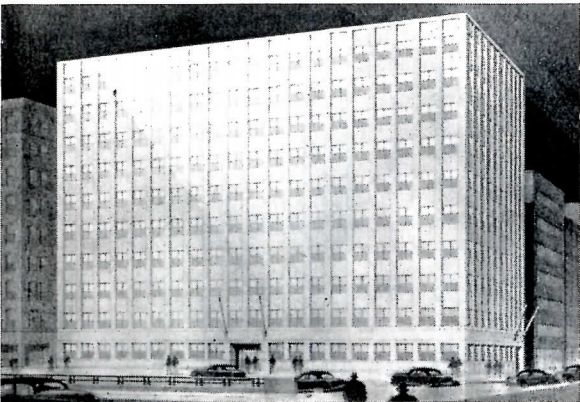

Above: Sinclair Oil Building is first new office building to be erected in Chicago's Loop since 1930s. Owners: Suffolk Corp., a subsidiary of John W. Galbreath & Co. Inc. Architects: Holabird & Root & Burgee. Below: administration building for Esso refinery, Bayway, N. J., was planned specifically to accommodate modular furniture. Architect: Lathrop Douglass

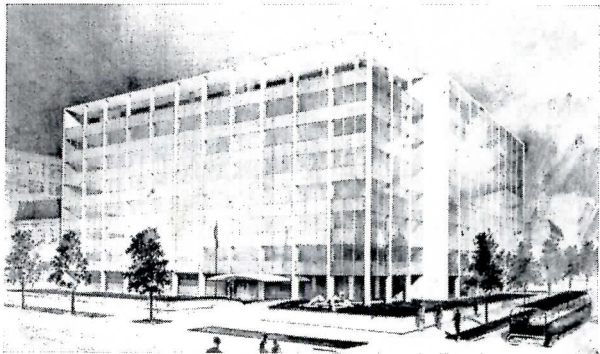

Above: first unit of proposed \$5 million Education Center for National Education Association in Washington, D. C.; architect, Joseph H. Saunders; consulting architects, Reisner & Urbahn. Below: Eggers & Higgins are architects for Standard-Vacuum Oil Company's \$15 million international headquarters building in Harriman, N. Y.

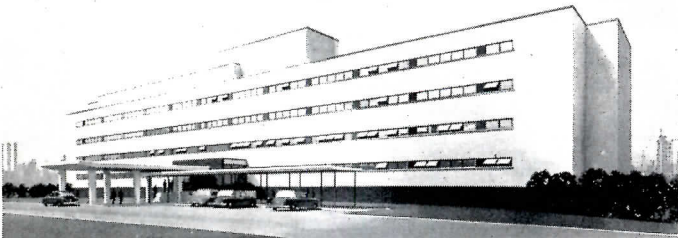

As Federal spending drops: HOW MUCH BUILDING DO CITIES PLAN?

American cities will spend more than \$6 billion on construction in the next three years — \$2,374,000,000 of it on public buildings other than schools — according to estimates based on a recent survey by *The American City* magazine. The figures reflect an increase in number of projects, in average cost of project and in total expenditure when compared with the past three years and offer some clues to trends in municipal construction of the next few years. Harold S. Bullenheimer, editor of *The American City*, also lists some other reasons for optimism about the municipal building market in this special report on the survey for ARCHITECTURAL RECORD.

TO SECURE ESTIMATES of probable expenditures for the construction of municipal public buildings during 1954-'55-'56 in comparison with similar expenditures for 1951-'52-'53, *The American City* magazine addressed a letter and questionnaire on October 1 to a liberal sampling of mayors throughout the United States. The letter went to all of the 107 cities listed in the 1950 census as over 100,000 population; to half of the 126 cities between 50,000 and 100,000; and to a quarter of the 1030 places between 10,000 and 50,000 — a total of 427 municipalities addressed. Up to December 10, when this paper was prepared, 1781 replies had been received from the 427 municipalities addressed — a 42 per cent return, which can be considered to be an excellent response.

These 178 cities of over 10,000 inhabitants had a 1950 population of approximately 23,000,000. They ranged from such large cities as Chicago, Philadelphia, and Los Angeles to small communities such as Sanford, N. C., Wood River, Ill., and West Monroe, La. New York was not included.

A total of 854 municipal buildings aggregating \$434,595,000 were reported as placed under contract in 1951, 1952, 1953; and 950 buildings aggregating \$619,416,000 as probable for contract in 1954, 1955, 1956. The latter are listed by types in table 1.

Table 2 gives these base figures for the reporting cities divided into three population classes, and the estimated total figures for all urban areas extended on a straight population basis. The re-

(Continued on page 254)

Table 1

1954-1955-1956 BUILDINGS PROPOSED *

Type of Project	Number	Reported by 178 Cities Aggregate Cost
City halls	35	\$ 51,538,000
Police stations	31	8,720,000
Fire houses	143	16,184,000
Garages, warehouses, or shops	122	27,313,000
Water plant buildings	80	117,359,000
Sewerage plant buildings	71	105,582,000
Incinerators	26	27,100,000
Libraries	38	15,456,000
Auditoriums	23	34,542,000
Hospitals	22	53,440,000
Park and recreation buildings	217	26,228,000
Public housing projects	7	57,672,000
Terminal buildings	21	15,730,000
Other structures	114	62,552,000
Totals 1954-1955-1956	950	\$619,416,000
Totals 1951-1952-1953	854	\$434,595,000

*Probable contracts, exclusive of land

Table Two

WHAT THE SURVEY COVERED

Number of cities	Over 100,000	50,000-100,000	10,000-30,000	Total
Total cities in group	107	126	1,030	1,263
Number addressed	107	63	257	427
Number replying	48	27	103	178
Population				
Of cities reporting	18,996,000	1,916,000	2,183,000	23,095,000
Of all cities in group	44,312,000	8,931,000	20,675,000	73,918,000

PROPOSED 1954-56 BUILDING *

Buildings reported (number)	Over 100,000	50,000-100,000	10,000-30,000	Total
By 178 cities	632	100	218	950
Buildings reported (value)				
By 178 cities	\$ 517,386,000	\$45,447,000	\$56,583,000	\$ 619,416,000
If extended to all cities over 10,000	1,201,000,000	202,000,000	588,000,000	1,991,000,000

ESTIMATED TOTAL URBAN † CONSTRUCTION * 1954-1956

Places of less than 10,000 aggregating 22,550,000 population; building estimated at \$17 per capita over the three years	\$ 383,000,000
Total public building program of urban communities 1954-1955-1956	2,374,000,000
Water and sewer lines and works, except buildings	2,170,000,000
Streets and highways	900,000,000
Power, transit, gas, port facilities, airports	750,000,000
Grand total municipal construction (exclusive of schools) estimated for 1954-1955-1956	\$6,194,000,000

*Exclusive of schools

†Urban territory as defined by the Bureau of the Census includes all cities and other incorporated places of 2500 population and over, plus places under 2500 in urbanized areas and unincorporated parts of such areas.

A.I.A. NAMES HAROLD D. HAUF DIRECTOR OF PUBLIC AND PROFESSIONAL RELATIONS

HAROLD D. HAUF, a former editor-in-chief of ARCHITECTURAL RECORD and former chairman of the Department of Architecture at Yale University, has been named by the American Institute of Architects to the new post of director of public and professional relations.



Mr. Hauf, who had served in the Navy during World War II, left the RECORD in May 1951, when he was recalled to active duty in connection with the Korean emergency. Since his release from the service in October 1952, he has been at Yale as a Research Associate and has served as technical manager of a defense research project carried on by the University for the Navy.

A 1927 graduate of the University of Michigan, with a B.S. in architectural engineering, Mr. Hauf also has an M.S. from Yale. From 1929 to 1949, when he

resigned to accept the RECORD post, he was on the faculty of Yale's Department of Architecture — with four years out during the war for service with the Navy's Bureau of Yards and Docks and a five-month leave in 1946 to serve as director of the Technical Branch of the National Housing Agency.

Mr. Hauf is a member of the A.I.A., the American Society of Civil Engineers and the Building Research Advisory Board of the National Research Council. He is the author of "Design of Steel Buildings," first published in 1932.

MUMFORD GETS AWARD FOR RECORD ARTICLE

LEWIS MUMFORD, author and architectural critic, received the second Howard Myers Award for distinguished architectural writing at a dinner held November 24 at the Architectural League of New York.

The award, established in memory of the late editor of *Architectural Forum*, was given for Mr. Mumford's article "Function and Expression in Architecture," which appeared in the November 1951 issue of ARCHITECTURAL RECORD. The award was first given two years ago to Walter Gropius for an article "Not Gothic But Modern for Our Colleges"

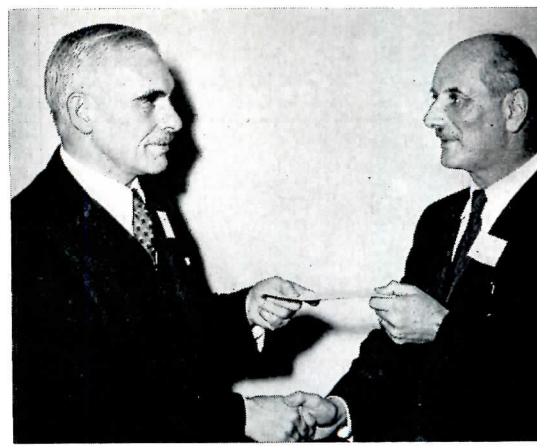

Tommy Weber



Lewis Mumford gets Howard Myers Award (above) from Lewis Adams for November 1951 article in Architectural Record (first page at left). Below: with Emerson Goble of the Record



Tommy Weber

in *The New York Times Magazine* of Oct. 23, 1949.

Mr. Mumford said he found special pleasure in receiving an award which honored Howard Myers, long his great friend, and in receiving it for an article in ARCHITECTURAL RECORD — remembering that the RECORD had first published the work of Montgomery Schuyler, "the only real architectural critic America has produced." The long series of articles in which Montgomery Schuyler reported, with sympathy and discernment, the birthpangs of contemporary architecture in America, began in 1891, the RECORD's first year.

The article for which Mr. Mumford received the award was one of the RECORD's present series on today's developments in the direction of an architecture for people, not things — an architecture not the slave but the master of technology. Contributors have included John Ely Burchard, Henry-Russell Hitchcock, Sigfried Giedion, Henry Churchill, Frank Lloyd Wright, Henry Hill, Richard Bennett, Osbert Lancaster, Joseph Hudnut, Pietro Belluschi.



—Drawn for the Record by Alan Dunn

"What'll I do with it—put it down the incinerator?"

HOUSING POLICY REPORT REFLECTS NEW EMPHASIS ON PRIVATE VS. GOVERNMENT HOUSING ACTIVITY

BY ERNEST MICKEL

A NEW APPROACH to the nation's shelter problems will emerge in Congress during the next few months. It is expected to reflect, in large measure, the detailed analysis and major recommendations contained in the December report of the Eisenhower advisory committee on housing. This exhaustive study, proposing more emphasis on private enterprise and less on government subsidy in housing, was the work of a 23-man committee chaired by Housing Administrator Albert M. Cole; it did not, however, necessarily carry his own views to the White House. He made his own report to the President.

If the suggestions of the advisory committee are to be carried out in legislation, the new program will loosen housing credit and endeavor to assure a more constant flow of mortgage funds through a Federally chartered, privately financed National Mortgage Marketing Corporation. This would provide a secondary market facility for FHA-insured and VA-guaranteed loans. It contemplates complete liquidation of the present Federal National Mortgage Association which is a part of the Housing and Home Finance Agency.

In drafting his housing message for Congress, the President had before him his committee's recommendation that FHA and VA maximum interest rates be set by a committee of government officials, but in no case higher than 2½ per cent above current average yield on outstanding government obligations of 15 years or more. (At mid-December, interest rates were limited by law at five per cent for FHA and 4½ per cent for VA.) The committee emphasized it felt there was no need for rate changes at the time it made its report.

Continuation of the present public housing program, at least temporarily, was advocated by the advisory group. It proposed an experimental two-year program during which the FHA would be authorized to insure 40-year, 100 per cent loans up to \$7600 per unit (or \$8600 in areas determined as "high-cost" by the FHA Commissioner). While not admitting that the committee had in mind here a total and complete substitute for public housing — if the experi-

ment worked out — Administrator Cole noted that continuation of the current low-rent public housing program was recommended "pending demonstrated progress of other programs."

A new gimmick in the proposal was the suggestion that occupants of such housing be given a chance to purchase the homes when their incomes increase sufficiently to enable them to meet normal credit standards. Minimum cash payments of \$200 would be required on this type of housing to cover initial costs. FHA would be authorized to issue prior commitments to builders, or owners of rental houses, up to 85 per cent of value with provision for conversion to a permanent loan up to 100 per cent of value upon sale. Herein, the committee envisioned a plan to provide — through private enterprise — a considerable volume of low-cost housing to relieve the

pressures for construction of subsidized shelter.

The report further would:

— Establish an Urban Renewal Administration, new constituent of HHFA, to carry on slum clearance and urban redevelopment, community facilities functions and any broader urban aids in rehabilitation and conservation.

— Establish a five-man Federal Home Loan Board in place of the present three-man Home Loan Bank Board to continue the present Federal Home Loan Bank System, Federal Savings and Loan Insurance Corp., and to Supervise the proposed National Mortgage Marketing Corporation.

— Establish a Housing Management and Disposition Administration as a new HHFA constituent for management and disposition of Lanham (war) and defense housing.

PORCELAIN ENAMEL CONFERENCE LOOKS AHEAD

PORCELAIN ENAMEL in the Building Industry," the recent two-day Washington conference co-sponsored by the Building Research Advisory Board and the Porcelain Enamel Institute, was a new-style conference for BRAB — the first to be devoted entirely to study of a single building material and the first to be conducted by the BRAB Institute.

There was general agreement that the potential for the porcelain enamel panel as a building material is tremendous. E. X. Tuttle, vice president of Giffels & Vallet, Inc., L. Rosetti, Associated Engineers and Architects, put it this strongly: "Porcelain enamel curtain walls, in my opinion, will be a major if not the most important single factor in the development of building types during the next 10 years."

While the porcelain-faced steel panel is more familiar today, it was noted that porcelain enamel on aluminum is an expanding field. E. C. Bricker, E. I. du Pont engineer, listed some of its advantages — stock panels can be cut readily on the job

to fit specific needs; the metal can be tempered even after the porcelain enamel is applied; and it can even be welded if care is taken. As for cost, Mr. Bricker said an important factor is the possibility of thinning the metal base to compensate for the added weight of the enamel, thus saving on metal used.

Possibilities of one special use were explored in a paper presented by G. W. Parker, a senior chemist at the Oak Ridge laboratory of the Atomic Energy Commission, who said that "because its fundamental chemical properties — resistance to contamination and ease of decontamination — are essential in radioactive chemical work, porcelain enamel is better suited than other materials such as stainless steel, plastics and other materials for the construction of fume hoods, fume ducts, glove boxes and work surfaces."

Other speakers included Architect William Lescaze of New York; Elmer Queer of Pennsylvania State College; and Dwight G. Moore of the Bureau of Standards.

this test shows

POWERS

Pneumatic System of TEMPERATURE CONTROL IS STILL GIVING ACCURATE REGULATION

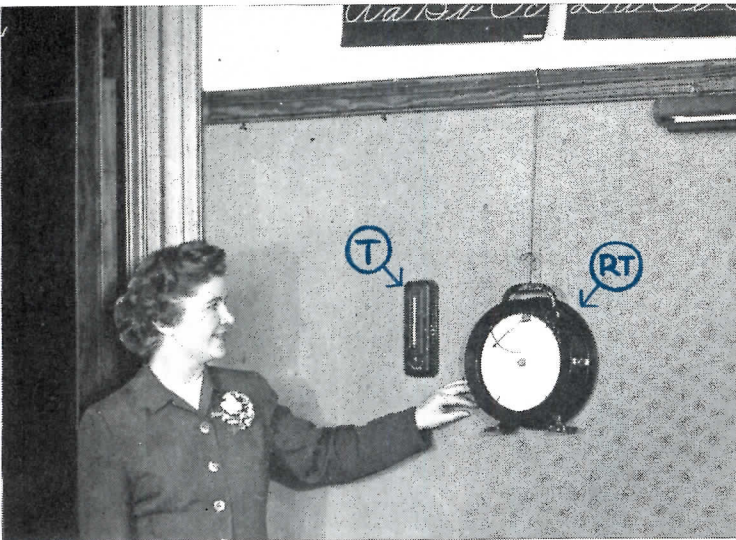

Miss K. Mart, Teacher in Room 14 Lincoln School, Racine, Wis. "T" is POWERS *Type A* Thermostat installed in 1903. It controls mixing dampers. Thermostat was set for 75° F. Note even control during schools hours. "RT" is Recording Thermometer which made charts at right in February 1953.

How is it possible for Powers systems to often give 25 to 50 years of dependable service?

Since 1891 outstanding features of a Powers thermostat have been: its powerful VAPOR-DISC with GRADUAL-ACTION and its famous non-bleed double valve. Proof of its superiority is revealed in the performance record shown here—as well as in many other old schools.

To get more years of better performance, greater comfort and fuel economy — install a POWERS pneumatic system of temperature control.

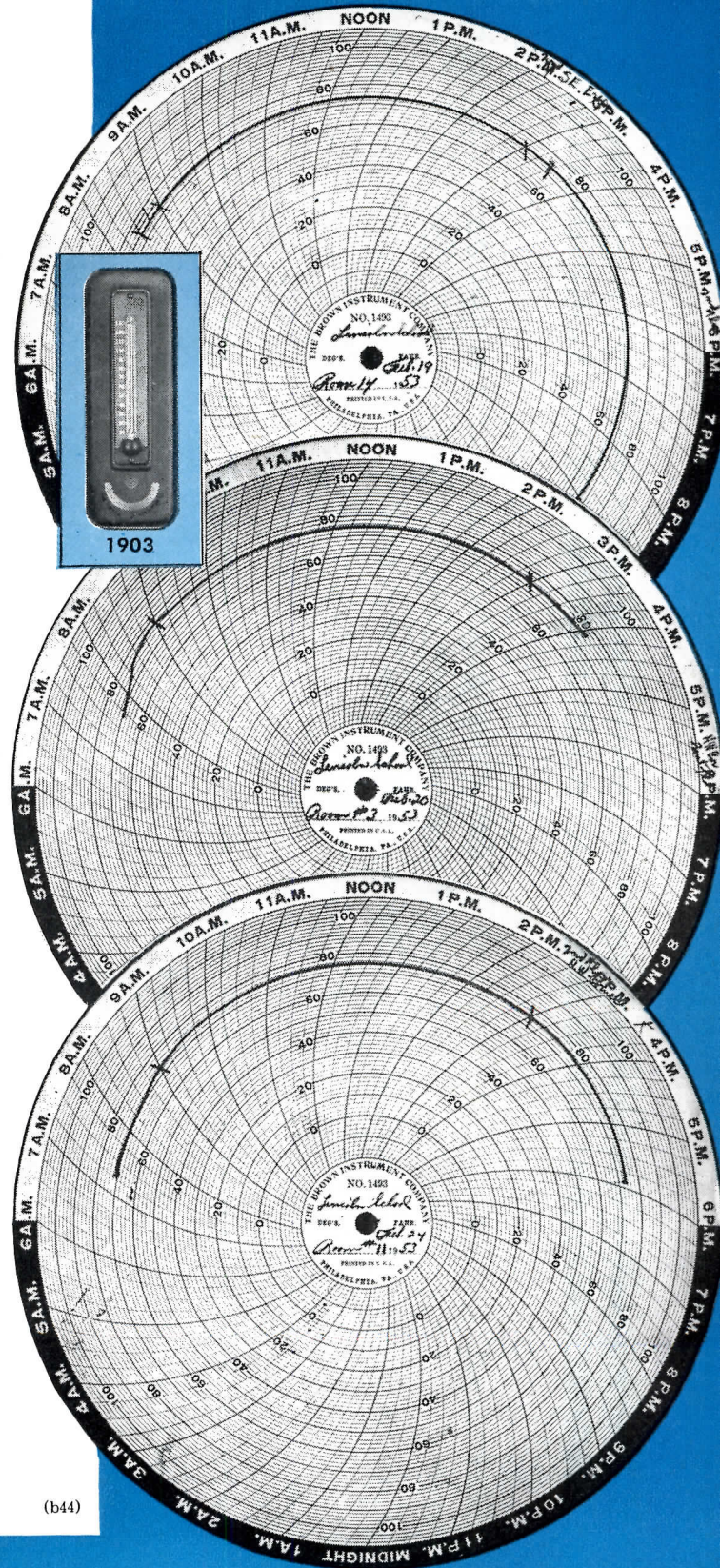

(b44)

THE POWERS REGULATOR COMPANY

SKOKIE, ILLINOIS

OFFICES IN OVER 50 CITIES IN U.S.A., CANADA, AND MEXICO • SEE YOUR PHONE BOOK

OVER 60 YEARS OF AUTOMATIC TEMPERATURE CONTROL



**ANOTHER MIES BUILDING
AND A NEW MIES DESIGN**

CARMAN HALL, a \$1,150,000 student-staff apartment building and the 15th structure designed by Ludwig Mies van der Rohe as part of his over-all scheme for the 110-acre Chicago campus of the Illinois Institute of Technology, was dedicated November 22. The nine-story glass and reinforced concrete building contains 96 apartments, mostly for staff and married students, with one floor reserved for coeds — the first housing for women at I.I.T.

Almost at the same time, a scheme by Mies (sketches bottom of page) for a convention and exhibition hall for Chicago was proposed by the City's South Side Planning Board. Mies' design, intended to allow the building to be put to as many uses as possible, would provide a one-story structure 700 ft sq and 100 ft high with no interior columns or fixed partitions. A two-way steel truss system would occupy the top 30 ft of the building's height: columns spaced at 100-ft intervals would take the roof load; vertical trusses in the exterior walls would take the wind load. Around the entire perimeter of the building would be a 20-ft arcade. Walls would be "an opaque material, such as marble." Seating capacity would be 50,000; cost is estimated at \$10 million. Restaurants, meeting and conference rooms and other service facilities would be placed in adjoining buildings.



Carman Hall is the second to be built of a group of four to six proposed multi-story apartment buildings for married students and staff at I.I.T. Below: left, lobby; right, typical apartment

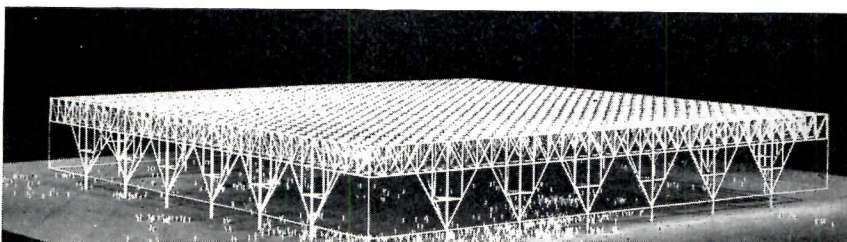
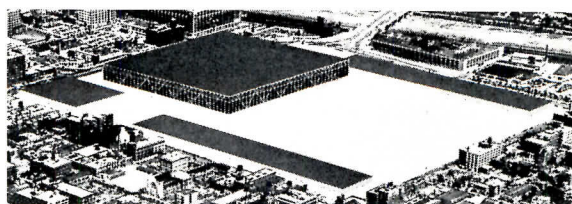

It's the *Sherardizing* process that fortifies Sherarduct—a *dry galvanizing* process that actually *alloys* corrosion-resistant zinc to the steel wall under heat. This is galvanizing at its best!

Sherardizing provides a 100 per cent uniform protective zinc coating over all surfaces, including the hill and valley of every single thread—safeguarding the conduit system against rust and corrosion for all time. *This is Sherarduct, galvanized conduit at its best!*

Still further protection is provided by the *baked-on* Shera-Solution, an alkyd-like enamel that seals the zinc against acids and other corrosive elements. Sherarduct Conduit provides positive protection for all wiring!

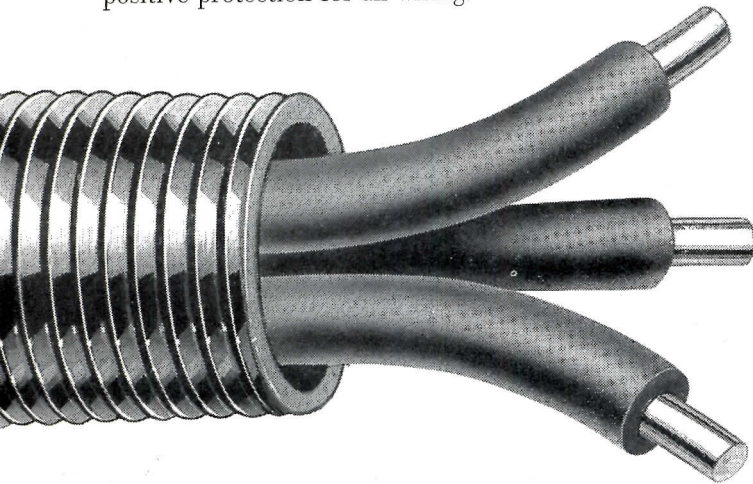

Proof of SHERARDUCT quality:

Write for the booklet, "Facts about Sherarduct." Learn more about the Sherardizing principle—how it makes Sherarduct "galvanized conduit at its best."

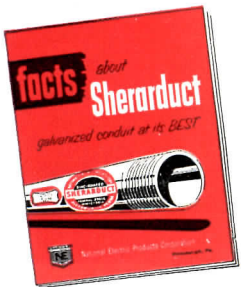

Insist on National Electric SHERARDUCT.

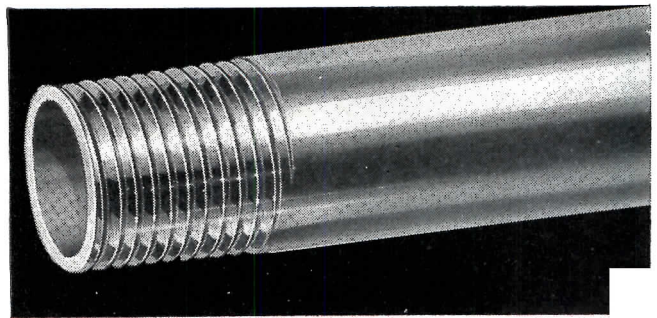

Threaded before Sherardizing

Sherarduct threads are cut *before*, not after, galvanizing. Even the base of the clean, sharp threads has *uniform, full zinc protection.*

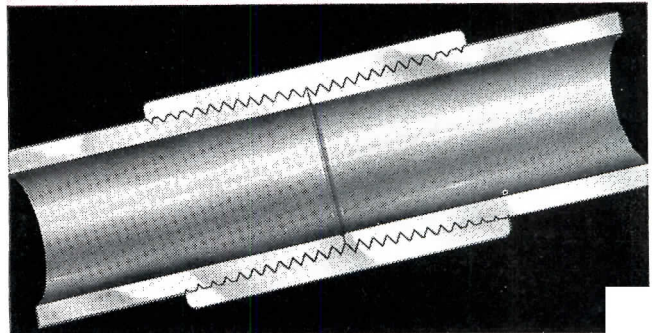

Protection for Threads

Surfaces and threads of the Sherarduct coupling are fully zinc protected. Accurately cut threads permit butting of conduit within the coupling—provide complete protection of the entire conduit system.



Works easily . . . Fishes easily . . .

Bends without flaking

Gradual heating and cooling of the Sherardizing process normalizes the metals. Result: easier working, forming and bending on the job. Butted joints leave no gaps to interfere with "easy fishing."

EVERYTHING IN WIRING POINTS TO

National Electric Products

PITTSBURGH, PA.

3 Plants • 7 Warehouses • 34 Sales Offices



O P I N I O N

“WHERE THE GREAT CITY STANDS”

Editor, ARCHITECTURAL RECORD

I would like to take advantage of the reader's privilege to answer without being asked. At the dinner given by the Architectural League in honor of Lewis Mumford and made possible by your farsighted editorial policy, harsh criticism was leveled against city development and city negligence. Planning and housing, it was pointed out, have failed. Our big cities are hopeless sores on the body of the earth, whose ills can at best be isolated with the isolation of the leper, ringing a loud bell that warns all callers that contact may be deadly.

From Ebenezer Howard to Frank Lloyd Wright, and from William Morris to Lewis Mumford, the city has been declared evil. The solution for man's happiness has been sought in green-belt towns and progressive suburbs, with man and community living in foolproof salubrity. And from Ur, Nippur, and Damascus to Rome, London, and New York, men have flocked to the airless, sunless, stone piles, suffering each other's proximity rather than that of the bird and the bee, long before high land prices forced maximum density, and industry and commerce created the quagmires of city slums.

Denunciation of city conditions and regional planning all seem to disregard the two basic facts, that man does not live by sanitation alone, and that we can't have our real estate and eat it too. There are and forever will be congenital city dwellers and congenital country dwellers, and no amount of sanitation in the broadest meaning of the word — sanitation of the soul and the body, so to speak — will make a country dweller out of a city dweller. There are millions of Americans, who, in spite of regional planning and *House Beautiful*, do not enjoy being Sunday ushers or Elk presidents, who are bored by bridge and group television, and who do not want to bake cookies for the benefit of Girl

Scouts. They hide behind the cold impersonality of a numbered apartment door not sinister tendencies, but the cherished right to be anonymous, to associate not at all, or with unwanted minorities, to remain unquestioned about the time schedule of their waking hours, and to vote for Stevenson, if they please, without the League of Women Voters knowing about it.

“STADTLUFT MACHT FREI” is an ancient German proverb, going back to the early Middle Ages, when escaped feudal serfs banded together in fortified settlements against the oppressive confinements of rural existence; and Walt Whitman, with magnificent exaggeration, wrote his hymn: “Where the great city stands.” It is one of the gains of modern transportation and communication that it enables man to make his choice. As the decades go by, the population will more and more divide into the procreating, group-abiding country dweller, and the individualist in the high- or low-cost city slum. The value attached to city life by the incurable “citizen” is far greater than any of the benefits of mortgaged home-ownership, around the bulldozed idyll of a company-owned “Village Green.”

It has been said that arguments in favor of city existence, under the prevailing chaotic circumstances, are confined to the rootless *haut monde*, living on race tracks and penthouse terraces, and to the “shady birds” who hang at night from the rafters of Johnny's Bar, or discuss subversive subjects at the Eighth Street Club. But that is not true. Lower middle class people and workmen like tight quarters as much as their well-heeled or well-informed brothers. A poll, taken around 1938 among Long Island slum dwellers, furnished conclusive evidence that the vast majority of this group preferred the flat to the bungalow. City housing acquires a somewhat different perspective when

one accepts a meaning of the city *beyond* the provision of sanitary shelter.

It doesn't take more than one sentence to denounce the poor design, the moronic uniformity and low production standards of our low-cost housing projects; but THEY WERE ATTEMPTS TO FIND INDIGENOUS SOLUTIONS FOR AN INDIGENOUS PROBLEM. Instead of forcing a typical big city population into the ribbon developments of England, mass housing projects acknowledged the congregational character of town living. No matter how poor and inadequate the results have been, the low-cost housing projects are almost a miracle by nothing else but their mere existence. We cannot have free enterprise and eat it too. Free land speculation would, by all logical considerations, make social housing impossible. Yet it was done! A hundred years from now, my successor at Pratt will say to the class of 2053: “Capitalism was at its height in those days, and land in the big cities sold at thousands of dollars per square foot. And still they managed to put up 40,000 units on the most valuable ground they had, renting without profit to those who could not afford the high rentals of competitive housing.”

As all affairs of mankind, cities, too, have a self-regulating instinct. When Hell's Kitchen was razed, the saturation point had been reached, and the first curative measures could be devised. The mere fact that today angry men of the stature of Mumford and Churchill are deeply concerned about the shortcomings of what has been done so far is the strongest proof of the power of the city to impose change. Our levittowns will grow and spread, because they obviously cater to the taste and the needs of those who live there by their own free will. But those who are not of this breed, either spiritually, or racially, or economically, will gladly throw their whole support behind the brave men who are ready to fight for the second step that will produce — not romanticized “vertical villages” — but the place

“where the city stands that is beloved by these,
and loves them in return and understands them —
where outside authority enters after the precedence of inside authority
where the citizen is always head and ideal.”

Sibyl Moholy-Nagy
New York City

(More news on page 26)

FOAMGLAS[®] roof insulation helps Maytag maintain accurate temperature and humidity control

FOAMGLAS roof insulation, installed on their Research and Development Building in 1944, has given outstanding insulating performance to The Maytag Company, Newton, Iowa. Maytag reports that insulating their roof with FOAMGLAS has proved an effective aid in controlling with constant efficiency the temperatures and humidities in their laboratories. FOAMGLAS does not absorb damaging moisture which can cut the efficiency of ordinary insulations. This has made FOAMGLAS a major factor in maintaining lower heating and air conditioning costs for Maytag during the past nine years. Maytag's experience has led them to state that they will select FOAMGLAS for their future insulation requirements.

Like Maytag, *your clients* will be well satisfied when

Within this modern Research and Development Building The Maytag Company carries out its program of translating ideas into better products to make life easier for the homemaker.

you specify FOAMGLAS for the roofs, walls, floors and ceilings of their buildings. The moisture-proof sealed glass cells of FOAMGLAS assure long, constant insulating efficiency . . . its rigidity and high compressive strength provide excellent structural and load bearing characteristics . . . and FOAMGLAS is fire-proof and rot-proof. To learn how you can best use FOAMGLAS, send for our brand new booklets covering its use for normal temperature buildings, refrigerated structures, piping and equipment. Write now, indicating your specific interest, to Department B-14 . . .

PITTSBURGH CORNING CORPORATION

One Gateway Center • Pittsburgh 22, Pa.

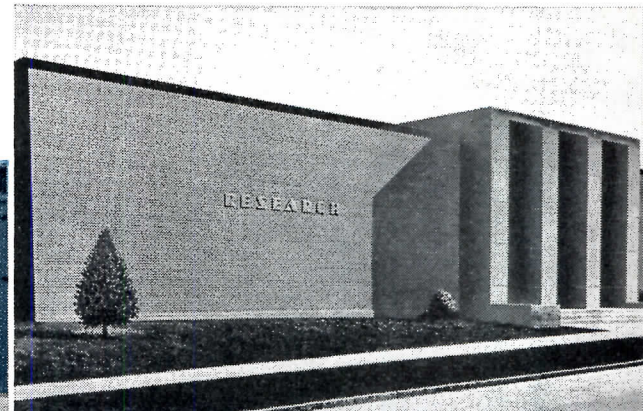
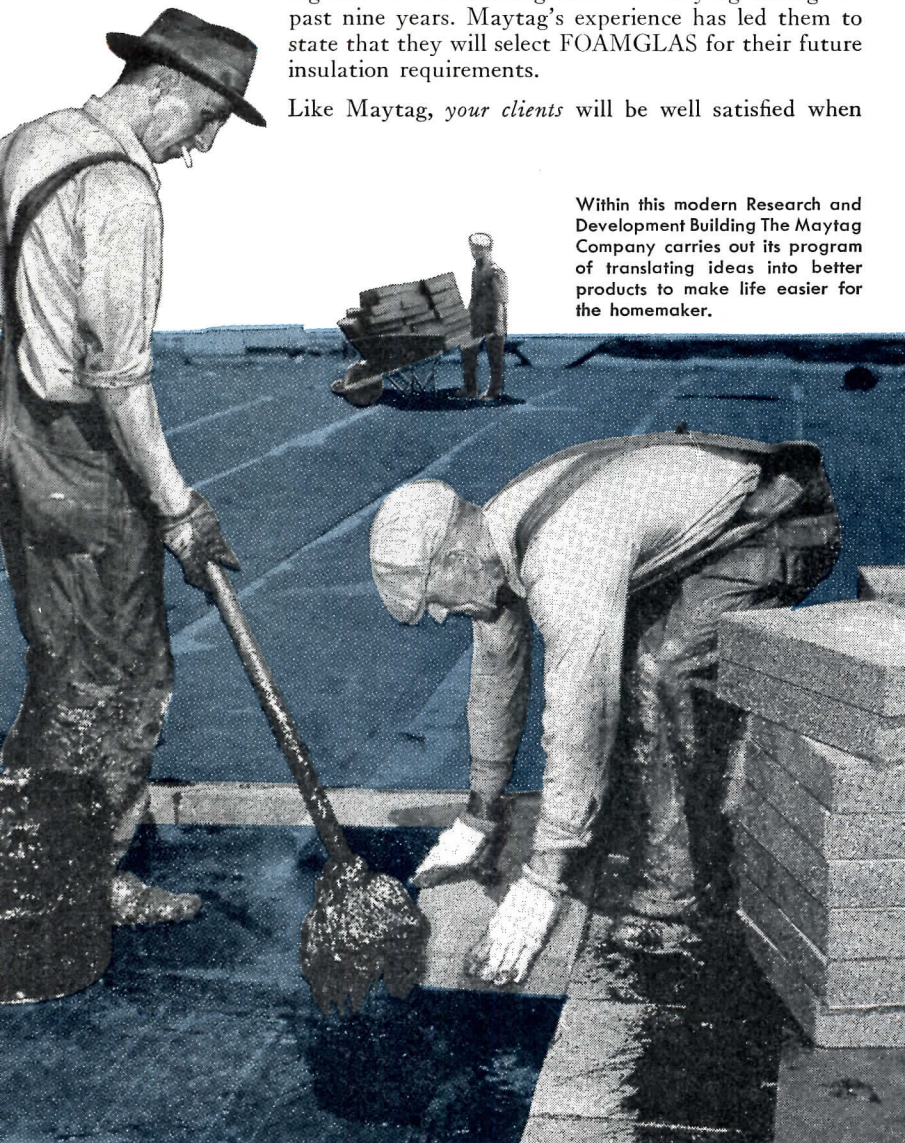

TYPICAL ROOF SECTION

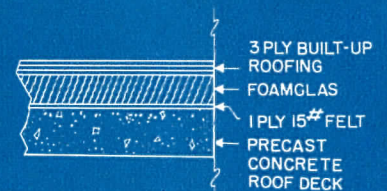

Architect (Supervising):
Proudfoot, Rawson, Brooks and Borg, Des Moines

Engineer:
The Austin Company, Cleveland

General Contractor:
A. H. Neumann & Bros. Company, Des Moines

Rofer:
Drake Roofing Company, Des Moines

Workmen find that the lightweight, easily handled blocks of FOAMGLAS are installed surprisingly fast. They are even able to move loaded wheelbarrows across the surface of the FOAMGLAS without damage to this strong rigid insulation.

FOAMGLAS[®]

the cellular glass insulation . . . it stays dry!

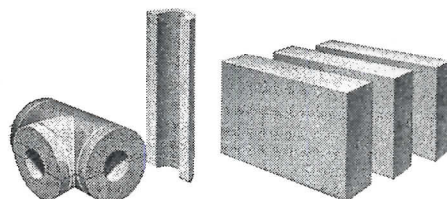

Pittsburgh Corning
also makes
PC Glass Blocks

\$12,000 IN PRIZES TO BE AWARDED IN COMPETITION

IN SEARCH OF a Canadian "house of tomorrow," McGill University's school of architecture and Calvert Distillers Ltd. have joined forces to sponsor an international competition. The company will provide \$12,000 worth of cash prizes and three Calvert awards.

The top winner will receive \$5000 in cash plus one of the trophies. To the best entry from Canada and to the best entry from abroad will go \$2500 and a trophy each, while there will be 10 honorable mention awards carrying \$200 prizes.

The problem calls for a house designed for a family of five (including three children under 15) which has one car. No price range or materials to be used are mentioned. Specifications are merely that it "should be in good taste, simple in design and pleasant in color without being impractical to maintain or too costly to build." It is to be centrally heated.

The competition is open to architects in Canada, Britain and continental Europe who are members of recognized architectural societies, bona fide employes whom they sponsor, and students of Canadian and European schools of architecture sponsored by their directors. Two Canadians and one European will be appointed as judges.

Deadline for submission of designs is April 1, 1954.

**VIS-À-VIS U. S. ECONOMY:
1954 CANADIAN OUTLOOK**

IF THE AMERICANS expect an economic down-turn, must Canada expect to be affected by it?

Not necessarily, says Dr. O. J. Firestone, economic advisor to the Department of Trade and Commerce. Dr. Firestone, who explains that he is expressing his personal views only, says that there are two aspects of the question as to whether Canadians will be affected by the decline predicted for the U. S. by

(Continued on page 30)



Tony Archer

1.

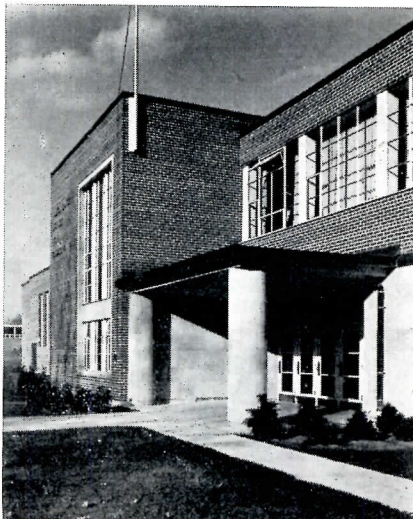

Arthur A. Gleason

2.

**SOME RECENT SAMPLES OF
CANADIAN SCHOOL DESIGN**

1. Ridgeview Elementary School, W. Vancouver, B. C.; Sharp & Thompson, Berwick & Pratt, architects
2. Tillonsburg District High School, Tillonsburg, Ont.; S. B. Coon & Son, architects
3. Princess Elizabeth Public School, London, Ont.; Robert D. Schoales, architect

3.





5000 people visited their "Young America" house opening day.

Again in 1953, the Snyders of Long Hill, Connecticut, have erected a G-E "Young America" model home, and again it is a proved success—5000 visitors the first day!

The new 1954 "Young America" Space-Maker Home Pro-

gram will be announced at The NAHB Convention in Chicago. G-E builder specialists will work with you, place at your disposal all the planning and promotion services of the G-E Home Bureau which have been so successful for other builders.

"Space-Maker" builder line!

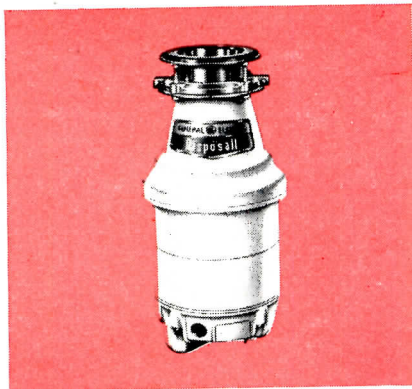

G-E DISPOSALL®

New Model FC-20 is designed especially for builders, at special low price. De Luxe Models FA-4 and FA-45 also available. All G-E Disposall models are designed for easy installation.

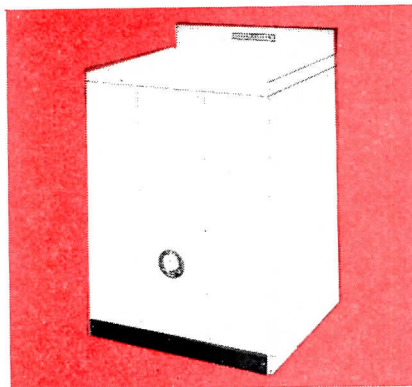

G-E WATER HEATERS

New, top-connecting table-top model is designed to save installation costs. All connections are located at top of tank for easy installation. Up to 82-gallon capacity. (Model illustrated: HG40-7A)

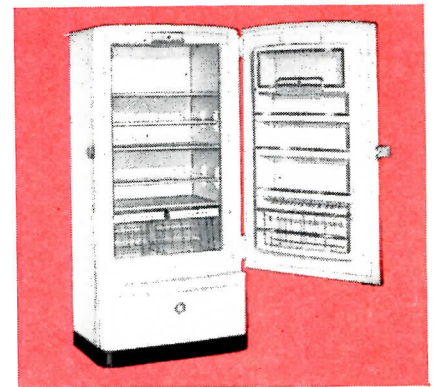

G-E FOOD FREEZERS

New 15- and 11-cubic-foot UPRIGHT freezers take little space. Also available in 11- and 7-cubic-foot chest-type models. Many new exciting features. (Model illustrated: HU-15)

Start selling your houses faster!

Isn't it time you took a good look at the facts, and the new, General Electric 1954 line?

Start selling your houses faster—just as many other alert builders are doing, from coast to

coast. Get the facts today.

See your local G-E distributor or write to the Home Bureau, General Electric Company, Appliance Park, Louisville, Kentucky.

See the 1954 G-E exhibit at the 1954 NAHB Convention—Booth Number 97.

Also at the G-E permanent exhibit, Merchandise Mart—Room 1117.

GENERAL  ELECTRIC

THE RECORD REPORTS

CANADA

(Continued from page 26)

American economists. The first is that there is no assurance that the Americans will in fact experience as much of a decline in economic activity as most of them seem to think will occur. The second is that there are good reasons why the Canadian pattern may vary some-

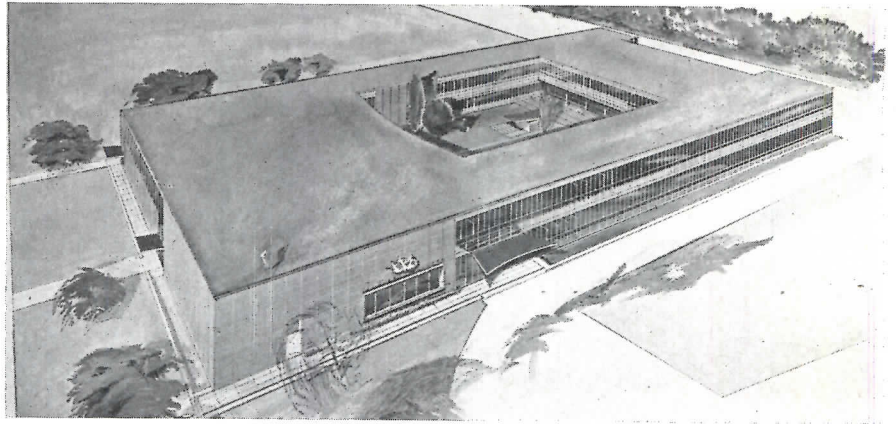

Plans for Ontario Teachers' College call for glass-walled classrooms and a center court with reflecting pool. Building will include gymnasium and auditorium (at left in rendering), cafeteria and library. Page & Steele were the architects

what from the American pattern. It did so, for example, in 1948 and 1949 when the U. S. had what was termed an "inventory" recession.

Four Basic Differences Noted

Dr. Firestone cites four basic reasons why the present state of the Canadian economy varies from that of the U. S.

First, he says, defense expenditures for almost a year have ceased to be Canada's dynamic force of economic expansion. Industrial, resources, commercial and residential development, rising consumer spending and good crops have been the main factors contributing towards expansion in output and incomes in this country. In the U. S. the emphasis on defense spending as a dynamic factor is still pretty strong.

Second, Dr. Firestone continues, the backlog of unfilled consumer requirements continues to be greater in Canada than in the U. S. Canadians are on the whole behind in many fields, such as the number of passenger cars, television sets, freezers and many household appliances.

Third, the impetus in Canada's resources development program appears to be much stronger than that in the corresponding program in the U. S. In part this is because of the growing raw material requirements of the free world at large and the U. S. in particular, with these countries turning to an increasing extent to Canada as a continuing source of supply in some fields.

Fourth, and Dr. Firestone considers this the most important reason of all, the Canadian economy is expanding more rapidly than the American. Con-

(Continued on page 32)

GLOBE SPRINKLERS

FIREMEN EVERY 10 FEET

YEAR 'ROUND SAFETY plus SAVINGS

Enjoy *permanent protection* against FIRE...as well as a large reduction in the cost of your FIRE insurance. How? Install a GLOBE Automatic Sprinkler System. Annual savings often pay for the system in 4 to 8 years. Ask for details.

GLOBE AUTOMATIC SPRINKLER CO.
 NEW YORK . . . CHICAGO . . . PHILADELPHIA
 Offices in nearly all principal cities

THEY PAY FOR THEMSELVES

Square D ML Panelboards give you . . .

LOWER INSTALLATION & MAINTENANCE COST
REDUCED "DOWN TIME"

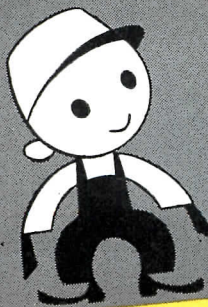

VAULT OR FLUSH LOCK
—important safety feature

TRIM CLAMPS
—indicating and self-aligning

CIRCUIT BREAKER UNITS
Thermal-Magnetic, Quick-Make,
Quick-Break minimize "down time"

HANDLE-LOCKING ATTACHMENTS
available to prevent unauthorized
circuit switching

COMPACT
Box widths range
from 20" to 40"

SOLDER-SOLDERLESS LUGS
simplify connections to
mains and branches

ADEQUATE GUTTERS
—generous wiring space

ADJUSTABLE INTERIORS
facilitate neat flush installations

REMOVABLE ENDWALLS
simplify drilling
conduit openings

SQUARE D'S TYPE ML CIRCUIT BREAKER DISTRIBUTION PANELBOARDS

provide complete, 2-way protection through the use of thermal-magnetic breaker units. Costly "down time" is held to a minimum since circuit breakers can be reset quickly after the fault has been cleared.

Four circuit breaker frame sizes provide ratings ranging from 15 to 600 amperes, 250 or 600 volts.

CONVERTIBLE
Breaker units
interchangeable with
higher or lower ratings

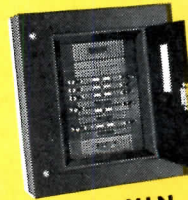

Type MLN



Type ML

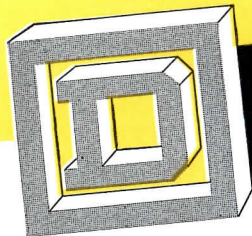

ASK YOUR ELECTRICAL DISTRIBUTOR FOR SQUARE D PRODUCTS

SQUARE D COMPANY

THE RECORD REPORTS

CANADA (Continued from page 30)

tinuing a trend of more rapid post-war growth, from mid-1952 to mid-1953 Canada's population has risen by 2½ per cent; in the U. S., the increase has been a little over 1½ per cent. As long as Canada's population is growing more rapidly than that of the U. S., there is

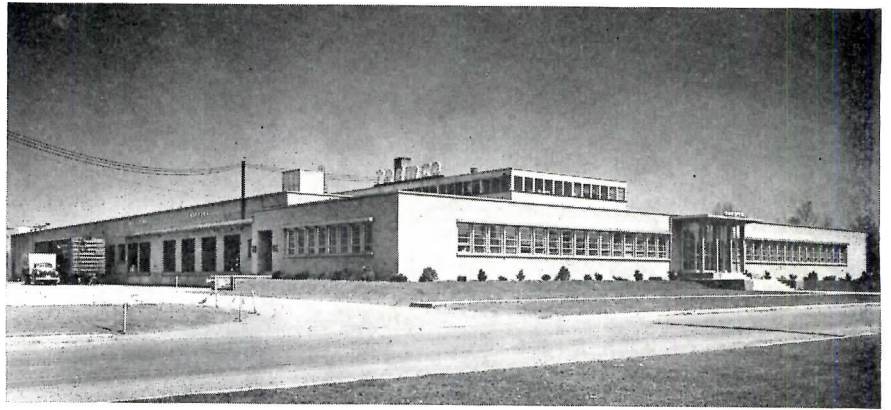

Above: a new factory building designed for Tremco Manufacturing Company Ltd. of Toronto by the firm of Marani & Morris, Toronto architects. Below: a close-up of the entrance



a firm basis for expansion of the domestic market.

Other Influences Considered

Bearing in mind these basic differences between Canadian and American economies, Dr. Firestone goes on to consider some of the major influences that may affect economic activity in Canada this year.

In the field of consumer expenditures, for instance, even if Canadians were not to increase their standard of living at all during 1954, an addition of another 350,000 Canadians, i.e., equal to the increase which took place from mid-1952 to mid-1953, would mean additional expenditures of some \$200 million on consumer goods and services.

With respect to investment, there is no assurance, Dr. Firestone states, that private capital expenditures in Canada will be down. Further, with public capital expenditures possibly rising a little, there are reasons to believe that the 1953 over-all level of investment may be fairly well maintained in 1954.

As regards exports, the situation remains uncertain, though there are some encouraging signs, says Dr. Firestone. One of these is a change for the better in the balance-of-payments position of

(Continued on page 36)

What does
this symbol
mean to

YOU?

★ ® ★

Yes, it identifies a qualified member of the National Electrical Contractors Association. But of particular concern to you, as an architect or engineer, it stands for:

- 1 A GUARANTEE**, in writing, covering parts and workmanship.
- 2 INTERPRETIVE ENGINEERING**, to interpret your plans accurately on the job, produce the results you plan for.
- 3 TRAINED MANPOWER**, an adequate pool of craftsmen, thoroughly trained from apprenticeship up, for any size job.
- 4 COMPETENT SUPERVISION**, by men who know electrical products, practices, standards and codes.

These factors and more mean protection of your ideas, your plans, your prestige. Why not discuss your next job with your Qualified NECA Contractor? You'll find his name by the NECA Seal in your Classified Telephone Directory.

**NATIONAL
ELECTRICAL
CONTRACTORS
ASSOCIATION**

**610 Ring Building
1200 18th Street N.W.
Washington 6, D. C.**



**SEE RUST-OLEUM APPLIED DIRECTLY OVER
SOUND RUSTED SURFACES! MAKE THIS
TEST UNDER YOUR OWN CONDITIONS AND
SEE PROOF OF PERFORMANCE!**

See Rust-Oleum 769 Damp-Proof Red Primer actually applied over a badly rusted surface after simple scraping and wire-brushing to remove rust scale and loose rust in the Rust-Oleum "rusted panel demonstration." Rust-Oleum's specially-processed fish oil vehicle penetrates rust to bare metal usually eliminating sandblasting and other costly surface preparations.

Rust-Oleum finish coatings in Aluminum, Green, White, Gray, Yellow, Black, Orange, Blue and others provide both *Rust Prevention and Decorative Beauty!* Specify Rust-Oleum for new construction, maintenance, and re-modeling. See Sweets for complete catalog and nearest Rust-Oleum Industrial Distributor, or attach coupon to your business letterhead.



See local classified telephone directory under Rust Preventives or Paints for nearest Rust-Oleum Industrial Distributor.



RUST-OLEUM[®]

**STOPS
RUST!**



There Is Only One Rust-Oleum. It Is Distinctive as Your Own Fingerprint. Resists Rain, Sun, Fumes, Snow, Heat, Salt Air, Salt Water, etc.



ATTACH TO YOUR LETTERHEAD — MAIL TO
THE RUST-OLEUM CORPORATION
2501 OAKTON ST., EVANSTON, ILLINOIS

I want to know more about RUST-OLEUM. Send me without obligation a FREE sample. I intend to test it indoors; outdoors; on wood; rusted metal; clean metal; brick; concrete; stucco;

(State on the above line object or structure such as tractor, tank, fence, metal sash, roof, floors, walls, etc.)

Subject to special conditions: weather; humidity; fumes; brine; dampness.

I have a chain-link fence. Please send full information on RUST-OLEUM's new Roller Method that cuts re-coating costs.

Send Complete Catalog with Color Guide

Please be sure to indicate Color Preference Here

Have Qualified Representative Call

NOTE: We want to supply you with the correct sample for your test. Please be sure to check off all appropriate information about your problem.

ACOUSTICAL MATERIALS AT WORK

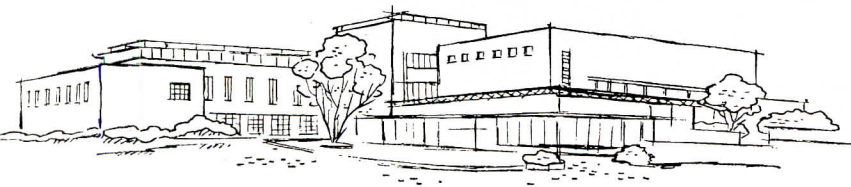

Architects:

Lawrence, Tucker & Wallmann

General Contractor:

Ross B. Hammond Co.

Acoustical Contractor:

Artcraft Linoleum & Shade Co.

ERB MEMORIAL STUDENT UNION, Eugene, Oregon

The dream of a generation of students at the University of Oregon came true recently with the opening of the new two-million-dollar Erb Memorial Student Union Building.

A convenient center for all campus activities, the Union has been especially designed with the students' comfort and welfare in mind. Even the ceilings help promote a pleasant, relaxing atmosphere, for they are noise-absorbing ceilings of Armstrong's Travertone and Cushiontone.

Throughout the lobby, corridors, and lounges, Travertone acoustical ceilings soak up distracting noise, allow students to read, study, or chat with friends in undisturbed quiet. A distinctively fissured mineral wool tile, Travertone blends well with the decorative scheme.

Armstrong's Cushiontone was used to sound condition the offices, auditorium, cafeteria, and library. Cushiontone is a white painted, cleanly perforated wood fiber material. Its low cost and easy upkeep often make it the choice when large areas must be sound conditioned economically.

Your local Armstrong Acoustical Contractor will be glad to give you complete information on Travertone, Cushiontone, and Armstrong's other acoustical materials. For the free booklet, "How to Select an Acoustical Material," write Armstrong Cork Company, 4201 Rock Street, Lancaster, Pennsylvania.



The wide use of marble, brick, and other hard-surfaced materials in the lobby made efficient acoustical treatment a real necessity. The handsome Travertone ceiling absorbs up to 75% of the noise that strikes its surface, preventing any build-up of high noise levels.

Prices geared to fit the student's budget make the good food served in the cafeteria especially attractive. The noise-absorbing Cushiontone ceiling also contributes to an enjoyable mealtime atmosphere.

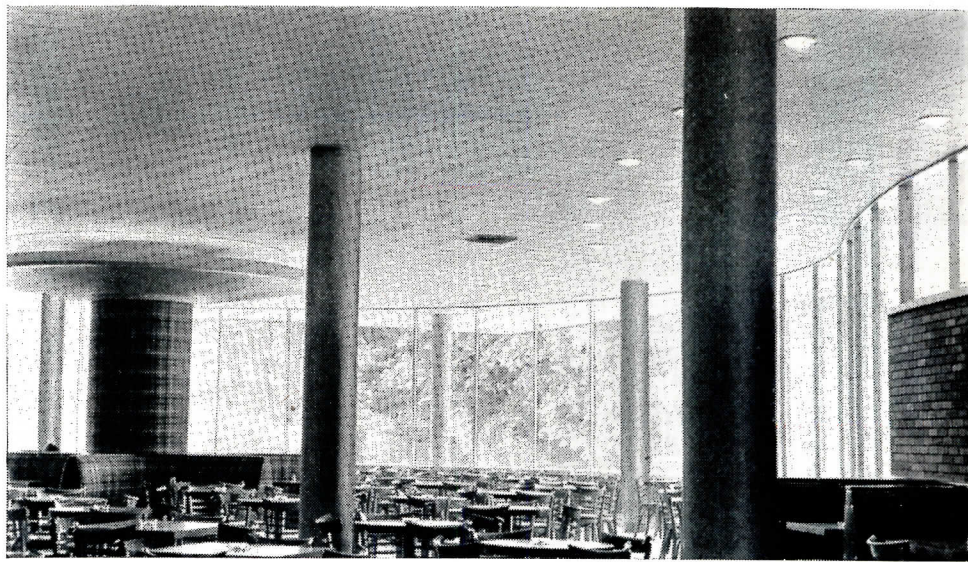

The clean, modern lines of the lobby are accentuated by the striking appearance of the Travertone acoustical ceiling. Not only is Travertone an integral part of the décor, its incombustible composition is an aid to fire-safety.

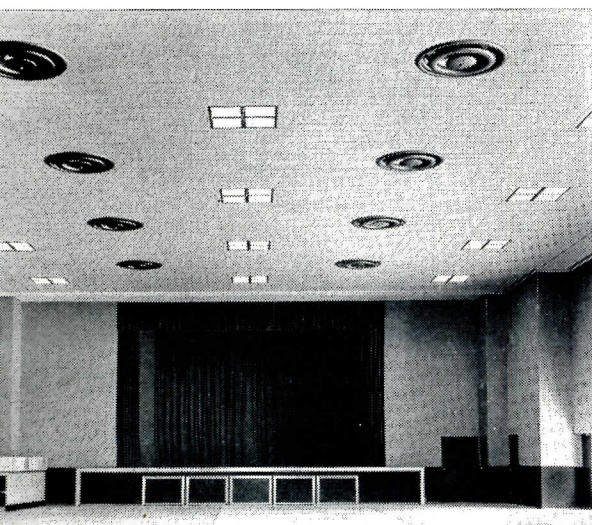
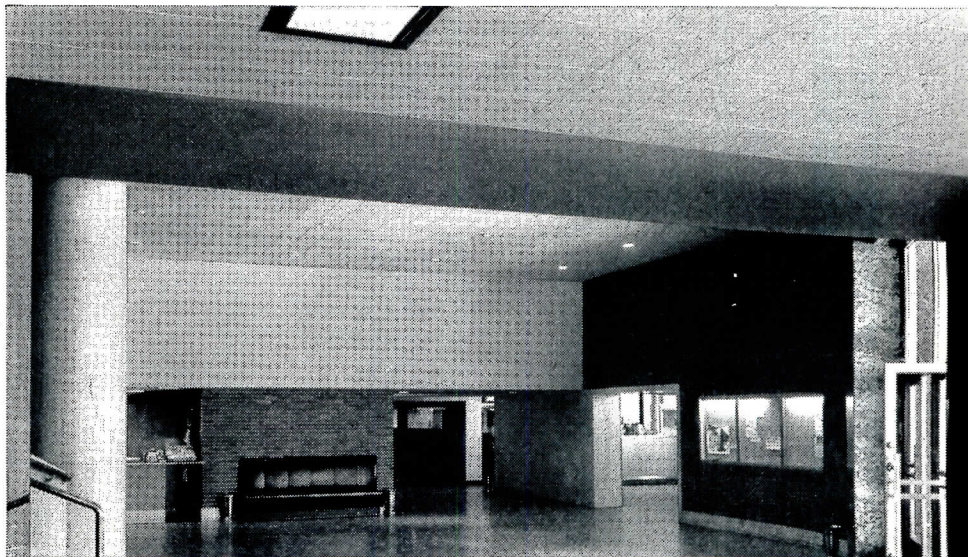

Although spacious in itself, the ballroom may be enlarged by the removal of the electrically operated walls on two sides. Whether in use as a dance floor or an auditorium, proper acoustics are assured by the Cushiontone ceiling.

ARMSTRONG'S ACOUSTICAL MATERIALS

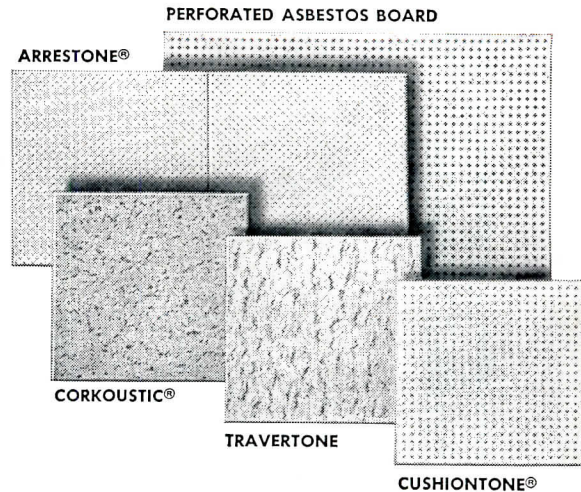

CANADA

(Continued from page 32)

the United Kingdom and the Western European countries.

As to exports to the U. S., these may be affected should the U. S. experience a prolonged recession, Dr. Firestone continues. But should there be only a short and comparatively mild downturn in business, Canadian trade may be affected only a little. In fact, in the 1948-49 American decline, Canadian exports actually rose in aggregate.

Drawing together the various indicators of economic activity, Dr. Firestone concludes that there is little indication that the level of employment and income in Canada may be lower in 1954 as a whole than in 1953. The odds are for an increase rather than a decline in economic activity in Canada during the coming year.

CIVIC PLANNING GROUP HOLDS ANNUAL MEETING

The Community Planning Association of Canada recently held its annual meeting in Quebec City, in conjunction with a Quebec regional conference sponsored by the association.

After summarizing the association's achievements of the year, retiring president H. V. Jackson of Vancouver, B. C., went on to urge members to participate to an even greater extent in the planning of communities. He did not mean, he said, that members should try to replace professional planners but that they should be more readily available to initiate and assist in the implementation of specific projects.

Among ways in which members can extend their usefulness, Mr. Jackson suggested: encouraging community centers and obtaining the participation of people in community centers in planning; publicizing existing and additional material regarding the need and advantages of decentralization; publicizing existing and additional material regarding the need and advantages of regional and metropolitan planning; encouraging greater control of subdivisions; encouraging planners to take part in civic administration; continuing efforts to provide adequate and satisfactory housing; and drafting model forms of legislation.

(More news on page 38)

WHAT'S YOUR I. Q.
ON NATURAL, RED OR WHITE
Birch?



HARDWOOD PRODUCTS
Solid Core DOOR

VENEER DATA helps you maintain uniformity on all specifications

Do you know that most Birch veneer used in quality doors comes from one specie? Confusing as it may seem, Natural, Red and White Birch actually all come from the Yellow Birch tree! Regardless of type, however, HPC Birch Veneer doors are carefully matched for a pleasing decorative effect.

NATURAL BIRCH (sometimes referred to as unselected) is a mixture of heartwood (Red) and sapwood (White). Natural Birch is selected for quality but not for color. It is available on Hardwood Doors in 1/20" Rotary Cut, 1/20" Sliced, 1/8" and 1/4" Sawn veneers.

RED BIRCH is the heartwood of the Yellow Birch tree, and is selected for both color and quality. Selected Red Birch Veneer on Hardwood Doors comes in 1/20" rotary cut and 1/20" sliced.

WHITE BIRCH is the sapwood of the Yellow Birch tree and is selected for both color and quality. Selected White Birch Veneer on Hardwood Doors is available in 1/20" Rotary Cut and 1/20" Sliced.

Don't take chances with veneer species, color or grain when matching doors or surroundings. Consult us or refer to Sweet's $\frac{15c}{HA}$ file for complete veneer data on Hardwood *Solid Core* doors — the quality door you'll surely specify when only the best will suffice.

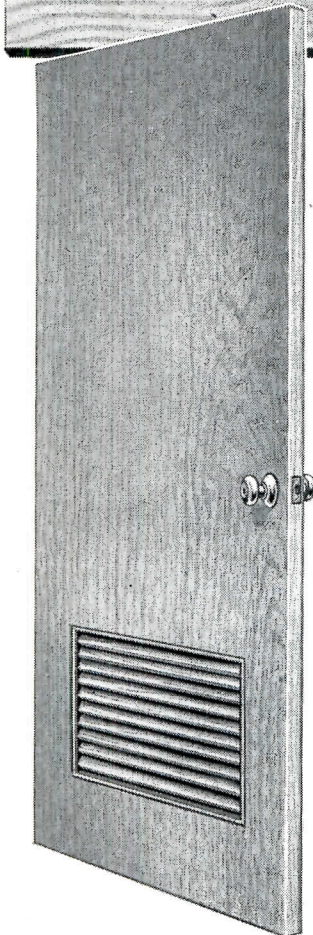

Custom-Built FOR YOU!

You can specify any type HARDWOOD Doors with full confidence that they will meet your specifications. All, are made-to-order and guaranteed free from defects of workmanship and materials.

HARDWOOD RIVERBANK

Sound Insulating Doors



America's finest doorway closure for reducing noise penetration — insuring room privacy. Send for new FREE brochure describing RIVERBANK doors in "easy-to-understand" non-technical language.

Offices in
NEW YORK
BOSTON • CHICAGO
CLEVELAND

HARDWOOD
PRODUCTS CORPORATION **DOORS**

HARDWOOD PRODUCTS CORPORATION • NEENAH • WISCONSIN

A NEW STANDARD OF THERMAL COMFORT PLUS REAL FUEL SAVINGS through features found only in this **NESBITT SYSTEM**

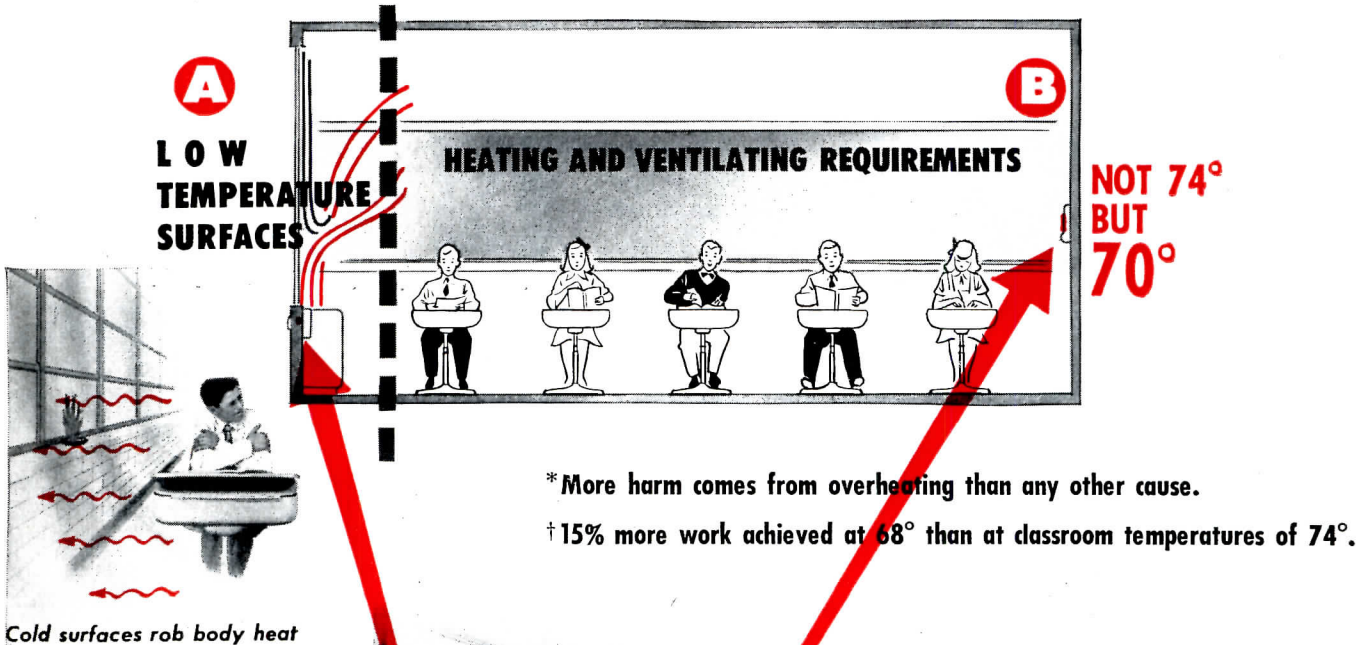

A This radiation provides a heat gain to the body in the presence of cold wall and window surfaces. It does so for the full length of windows. It continues this protection against the discomfort of these cold surfaces even after the unit ventilator has satisfied the general heating requirements of the room. This no other system does. Moreover the warm convection heat currents flowing upward and over the cold surfaces completely eliminates downdraft.

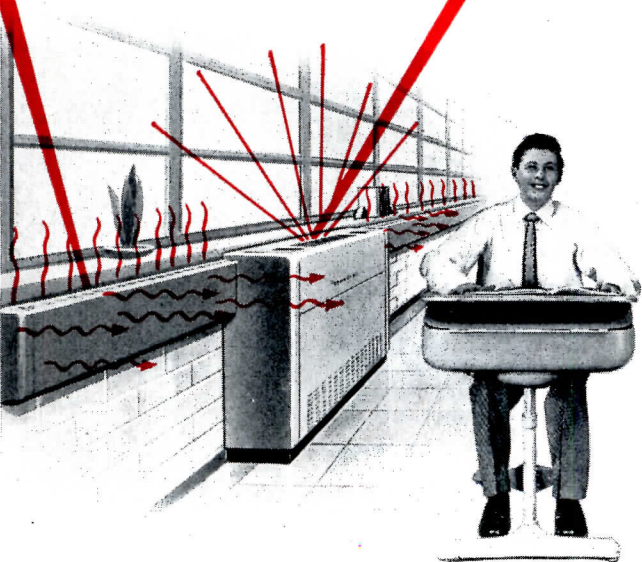

B Room temperatures may often be 4 to 5 degrees lower when protection from the chilling effects of cold surfaces is provided. So frequently overheating is the result of an attempt to provide better thermal comfort by a higher ambient temperature whereas what is needed is not more total heat but heat at the right place. This is just what Nesbitt Wind-o-line does. This difference of 4 to 5 degrees also means a reduction of upward of 5% of your heating fuel cost.

*†Source—Report of New York State Commission on Ventilation.

This new standard of thermal comfort and these fuel savings are available to you now, but to get them you should insist on

NESBITT *Syncretizer* **WITH WIND·O·LINE**
MADE AND SOLD BY JOHN J. NESBITT, INC., PHILADELPHIA 36, PA.—SOLD ALSO BY AMERICAN BLOWER CORPORATION

SLUSSER SAYS HE'LL BE PUBLIC HOUSING "VOICE"

THE MOST ELOQUENT DEFENSE of public housing in many a year has now been made by a Republican, Commissioner Charles E. Slusser of the Public Housing Administration, and it had the effect of putting Mr. Slusser's own position clearly on record for the first time.

Speaking before members of the American Municipal Association in convention in New Orleans, Mr. Slusser said he was present to make a case for public housing — "a case that needs to be made."

An example of the Slusser position: "It has been charged that public housing is 'creeping socialism.' If so, I have never in my travels met so many social-

ists disguised as Republicans. Bob Taft was such a one."

A 30,000-mile inspection trip had taken the Commissioner to every part of the nation. For three months he visited city after city and found invariably, he said, that the members of the public housing commission or authority were the town's leading citizens — the people guiding the community's business and professional life.

"These are not social theorists," he observed. "These are hard-headed, tough-minded, practical people who refuse to let their cities decay. They need a voice, and until they get a better one, they will have — for so long as it holds out — mine."

Mr. Slusser said he found in his travels that people understand less about public housing than they do about any other major problem of government. To counter charges that it is costly, the Commissioner told the city officials that the fiscal 1954 subsidy payments would total only \$40 million, or just one per cent of the outlay for foreign aid alone. Singling out other Federal subsidies, he cited mail service, over \$300 million; highways, \$420 million; rivers and harbors, \$234 million; reclamation and irrigation, \$169 million; commercial aviation, \$115 million; school lunch programs, \$82 million; and Indians, \$67 million.

Mr. Slusser summarized his "case" for public housing as follows:

1. It is the best tool we have for rehabilitating the slums of America and the people who live in them.
2. It is an investment that pays large municipal dividends in its reduction in police, fire and health costs in the areas in which it operates.
3. It represents a net gain in municipal income without the cost of collection that normal taxes entail.
4. It means a better life for all — every citizen profits from slum eradication. Public housing improves adjacent property, stops its deterioration.
5. Its costs are negligible, far outweighed in size by any number of other government subsidies.

TOO MUCH CONSTRUCTION? COMMERCE AIDE SAYS NO

Construction has not been "overdone" in Post-World War II years, the Commerce Department believes.

(Continued on page 224)

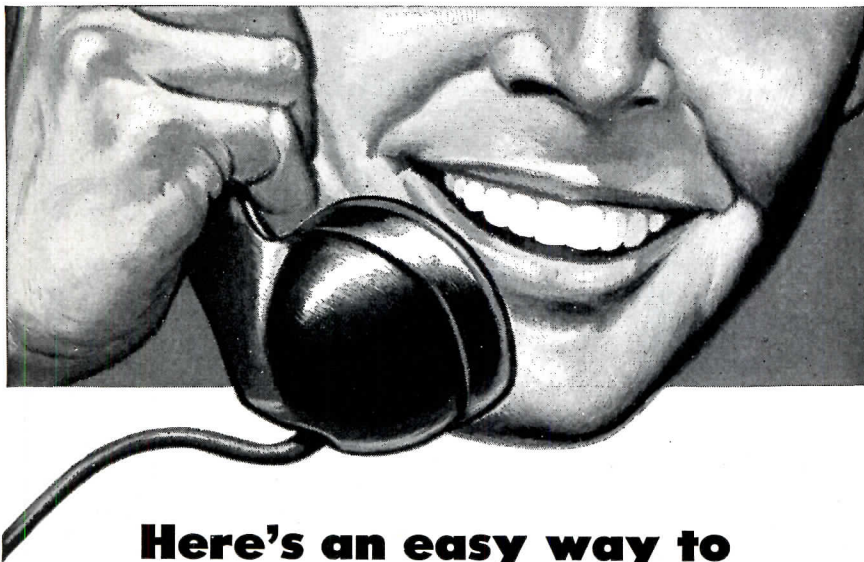

Here's an easy way to Plan a SOUND SYSTEM

Just call in your RCA Sound Distributor (he'll practically plan it for you!)

SOUND is a specialized field. That's why it's just good sense to pass your sound-system problems along to the man who works with sound every day . . . your own RCA Sound Distributor.

These men have had years of first-hand experience in working out sound systems for every possible application . . . for schools, hospitals, hotels, industrial plants, stores, airports, depots, auditoriums, churches. Their friendly

advice is your best assurance that the *sound system you lay out will always reflect credit on your good professional reputation.*

This helpful service is available virtually anywhere in the U.S.A. *No obligation, of course.*

So next time you have a question on sound systems, call your RCA Distributor. Or easier still . . . just mail the coupon below.

Sound Products, Dept. A3, Radio Corporation of America, Camden, N. J.

Without obligation on my part please have an RCA Distributor Sound Specialist call on me.

Name _____

Firm _____

Address _____



SOUND PRODUCTS
RADIO CORPORATION of AMERICA
ENGINEERING PRODUCTS DEPARTMENT, CAMDEN, N. J.

In Canada: RCA VICTOR Company Limited, Montreal

Complete Kitchen ...only 42 inches wide!

GENERAL CHEF 5-IN-1 is ideal for Motels
Hotels • Apartments • Small Kitchens • Trailers • Factories
—Wherever space and dollars are important!

- 1 DOUBLE SINK** One-piece porcelain top of heavy gauge steel. Faucet and all hardware triple-chrome plated.
- 2 BURNERS** Unit comes with 3 gas burners (easily adjusted for bottled, natural or manufactured (L.P.) gas), or 3 electric burners (220 V.).
- 3 OVEN** Large handy oven with broiler and Robertshaw Automatic Temperature Control. Completely insulated from refrigerator.
- 4 REFRIGERATOR** Six cubic feet of space. Electric sealed, self-oiling Tecumseh unit. Owens-Corning Fiberglas insulation. Convenient bottle shelves in door.
- 5 FREEZER** Holds 9 ice cube trays, or 12 standard frozen food packages.

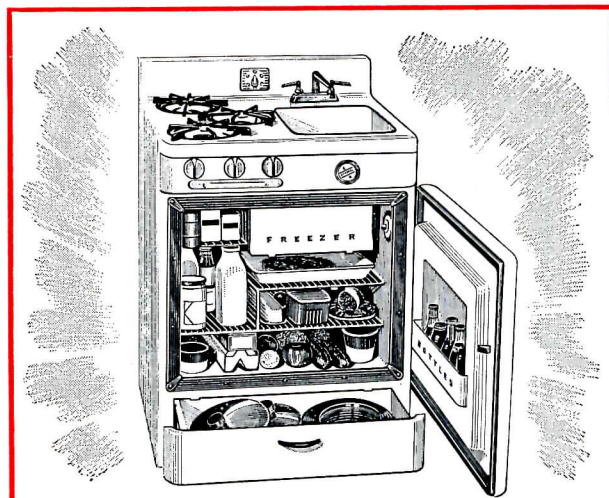

ALSO AVAILABLE...

Smaller units 27½ inches wide without oven—gas or electric

Handsome General Chef units without ovens come in sizes as small as 27½ inches wide. Gas or electric burners (either 110 or 220 V.)... with or without sink. Four cubic foot refrigerators.

WRITE...



We will send you complete information and specifications on the many General Chef complete kitchen units. If you are building, remodeling, designing—you will want to get this information to help you save space and dollars. Write today. We will also send you name and address of distributor nearest you.

General Chef,

4542 E. Dunham Street, Los Angeles 23, Calif.

Dept. D-1

Please send me complete information and specifications on General Chef units, and name of nearest distributor.

NAME _____ OCCUPATION _____

STREET & NUMBER _____

CITY _____ ZONE _____ STATE _____

CONSTRUCTION COST INDEXES

Labor and Materials

United States average 1926-1929 = 100

Presented by Clyde Shute, manager, Statistical and Research Division, F. W. Dodge Corp., from data compiled by E. H. Boeckh & Assocs., Inc.

NEW YORK

ATLANTA

Period	Residential		Apts., Hotels Office Bldgs. Brick and Concr.	Commercial and Factory Bldgs. Brick and Concr.		Brick and Steel	Residential		Apts., Hotels Office Bldgs. Brick and Concr.	Commercial and Factory Bldgs. Brick and Concr.		Brick and Steel
	Brick	Frame		Brick	Brick		Brick	Frame		Brick	Brick	
1930	127.0	126.7	124.1	128.0	123.6		82.1	80.9	84.5	86.1	83.6	
1935	93.8	91.3	104.7	108.5	105.5		72.3	67.9	84.0	87.1	85.1	
1939	123.5	122.4	130.7	133.4	130.1		86.3	83.1	95.1	97.4	94.7	
1940	126.3	125.1	132.2	135.1	131.4		91.0	89.0	96.9	98.5	97.5	
1946	181.8	182.4	177.2	179.0	174.8		148.1	149.2	136.8	136.4	135.1	
1947	219.3	222.0	207.6	207.5	203.8		180.4	184.0	158.1	157.1	158.0	
1948	250.1	251.6	239.4	242.2	235.6		199.2	202.5	178.8	178.8	178.8	
1949	243.7	240.8	242.8	246.4	240.0		189.3	189.9	180.6	180.8	177.5	
1950	256.2	254.5	249.5	251.5	248.0		194.3	196.2	185.4	183.7	185.0	
1951	273.2	271.3	263.7	265.2	262.2		212.8	214.6	204.2	202.8	205.0	
1952	278.2	274.8	271.9	274.9	271.8		218.8	221.0	212.8	210.1	214.3	
Aug. 1953	283.1	279.2	283.4	288.7	285.2		225.7	226.6	224.8	226.4	226.2	
Sept. 1953	284.7	279.2	288.5	295.3	291.3		225.6	226.5	225.8	226.8	227.0	
Oct. 1953	283.0	277.3	288.0	295.0	290.8		224.9	225.6	225.7	226.7	226.8	
Oct. 1953	% increase over 1939			% increase over 1939			% increase over 1939			% increase over 1939		
	129.1	126.6	120.4	121.1	123.5		160.6	171.5	137.3	132.8	139.5	

ST. LOUIS

SAN FRANCISCO

Period	Residential		Apts., Hotels Office Bldgs. Brick and Concr.	Commercial and Factory Bldgs. Brick and Concr.		Brick and Steel	Residential		Apts., Hotels Office Bldgs. Brick and Concr.	Commercial and Factory Bldgs. Brick and Concr.		Brick and Steel
	Brick	Frame		Brick	Brick		Brick	Frame		Brick	Brick	
1930	108.9	108.3	112.4	115.3	111.3		90.8	86.8	100.4	104.9	100.4	
1935	95.1	90.1	104.1	108.3	105.4		89.5	84.5	96.4	103.7	99.7	
1939	110.2	107.0	118.7	119.8	119.0		105.6	99.3	117.4	121.9	116.5	
1940	112.6	110.1	119.3	120.3	119.4		106.4	101.2	116.3	120.1	115.5	
1946	167.1	167.4	159.1	161.1	158.1		159.7	157.5	157.9	159.3	160.0	
1947	202.4	203.8	183.9	184.2	184.0		193.1	191.6	183.7	186.8	186.9	
1948	227.9	231.2	207.7	210.0	208.1		218.9	216.6	208.3	214.7	211.1	
1949	221.4	220.7	212.8	215.7	213.6		213.0	207.1	214.0	219.8	216.1	
1950	232.8	230.7	221.9	225.3	222.8		227.0	223.1	222.4	224.5	222.6	
1951	252.0	248.3	238.5	240.9	239.0		245.2	240.4	239.6	243.1	243.1	
1952	259.1	253.2	249.7	255.0	249.6		250.2	245.0	245.6	248.7	249.6	
Aug. 1953	264.9	257.5	261.9	271.0	263.9		256.6	249.8	259.0	263.7	262.2	
Sept. 1953	266.8	261.0	262.2	270.8	264.0		258.7	251.3	263.8	270.7	266.1	
Oct. 1953	265.4	259.2	261.9	270.6	263.6		258.7	251.3	263.8	270.7	266.1	
Oct. 1953	% increase over 1939			% increase over 1939			% increase over 1939			% increase over 1939		
	140.8	142.2	120.6	125.9	121.5		145.0	153.1	124.7	122.1	128.4	

The index numbers shown are for combined material and labor costs. The indexes for each separate type of construction relate to the United States average for 1926-29 for that particular type — considered 100.

Cost comparisons, as percentage differences for any particular type of construction, are possible between localities, or periods of time within the same city, by dividing the difference between the two index numbers by one of them; i.e.:

index for city A = 110
 index for city B = 95
 (both indexes must be for the same type of construction).
 Then: costs in A are approximately 16 per cent higher than in B.

$$\frac{110-95}{95} = 0.158$$

Conversely: costs in B are approximately 14 per cent lower than in A.

$$\frac{110-95}{110} = 0.136$$

Cost comparisons cannot be made between different types of construction because the index numbers for each type relate to a different U. S. average for 1926-29.

Material prices and wage rates used in the current indexes make no allowance for payments in excess of published list prices, thus indexes reflect minimum costs and not necessarily actual costs.

These index numbers will appear regularly on this page.

drafts before they start!

New! Exclusive Trane Unit Ventilator System creates Kinetic Barrier which (1) stops window downdrafts every minute room is occupied, (2) improves distribution of heated and ventilated air, and (3) operates quietly—virtually noise-free.

Not since the first unit ventilator has there been such a significant improvement in school comfort.

The new TRANE Unit Ventilator System actually accomplishes what architects, engineers, contractors and school authorities have long agreed would be the ideal.

How Trane System differs. The use of *warmed* air for intermittent "blanketing" of windows during the heating cycle has been common practice for many years. However, this still leaves pupils exposed to downdrafts since *cooling* is required about 75% of the time due to high heat gains. The new TRANE system differs in that it is effective at all times—during cooling as well as heating cycles. *It operates every minute the room is occupied . . . even when the heat is off.*

HOW TRANE Kinetic Barrier SYSTEM WORKS

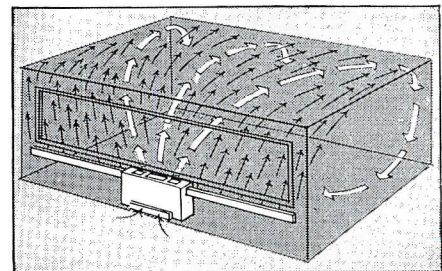
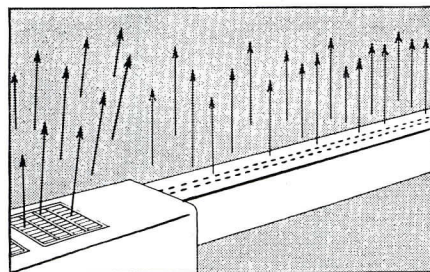

Outdoor and room air is drawn into the TRANE Unit Ventilator in desired proportions where it is blended, filtered and brought to the proper temperature. It is then forced upward from the central unit and from lateral extensions along the entire window wall.

Rising air creates Kinetic Barrier which blocks drafts at source, draws room air to ceiling. These air streams blend and circulate around room in a continuous draft-free cycle. Air fans out from central unit, assists air from extensions to penetrate every corner.

Report describes new system in detail. Just published. Contains results of an investigation of the TRANE Kinetic Barrier System of unit ventilation operating in an actual "problem" classroom during the winter of 1952. If you are concerned with modern schoolroom heating and ventilation, this report is "must" reading. Call your TRANE sales office for a copy today.

Trane matched products fit every school need . . . Convectors • Wall-Fin Heaters • Volume Ventilators • Projection Heaters • Horizontal Unit Heaters • Force-Flo Heaters • Climate Changers • Compressors • Air Conditioners • Water Chillers • Fans • Coils • Traps and Valves.

Kinetic Barrier refers to the wall of upward-moving air provided by TRANE KB Unit Ventilators. This action stops window downdraft, induces flow of room air, blends with main air stream from unit ventilator.

Kinetic Barrier system of Unit Ventilation

REQUIRED READING

Renewing Our Cities. By Miles L. Colean. *The Twentieth Century Fund* (330 W. 42nd St., New York, N. Y.) 1953. 5½ by 8 in. 181 pp., illus.

REVIEWED BY
HENRY S. CHURCHILL, F.A.I.A.

THIS is a dispassionate, and in general a pretty complete, review of the causes of urban disintegration and the complicated problems of "renewal." It is a plea for seeing the picture whole, for a clarification of objectives, and for planned long-term action rather than for spectacular "redevelopment" of the Moses type. Coming from so distinguished an authority, this is heartening indeed.

Colean emphasizes that the problem of renewal cannot be tackled by the city alone, but that it concerns the whole metropolitan complex. Without metropolitan area planning and controls, the suburbs and satellite cities are fast becoming as parlous as the central cities. Nor can "planning," by itself, be remedial. There must be controls, and these controls must have an objective. The many obstacles to establishing such controls, political, economic and legal are pointed out in detail; nevertheless the conclusion is that they must eventually come about.

The best point of attack, one gathers, is traffic control; indeed this is the prob-

lem in which greatest progress has been made. Compared to the difficulties that face the planner, the zoner, the redeveloper, the traffic engineers have comparatively clear sailing. Condemnation practices, a major difficulty in any redevelopment effort, have been smoothed for the highway builders. Public opinion apparently puts little objection in the way of highway finance. The New York City express-ways, the Philadelphia Schuylkill Expressway, the Detroit free-ways are approved and acclaimed. Yet the Detroit free-ways cost two hundred million dollars — two million a mile — and one central interchange alone takes up forty acres of land. Imagine trying to reserve such acreage for any rational use! The Schuylkill Expressway is ruining a part of Philadelphia's exquisite river approach: imagine the howls if it had been proposed to run another railway line there. And it is pretty certain that these vast and horrible concrete tracks will not relieve the central city traffic situation but will make it worse, because all the other things that Colean points out as essential to any over-all, progressive solution, are not being done:

"Until the question of the distribution of residence and business throughout a metropolitan area can be grappled with as a whole, even the most spectacu-

lar efforts to reduce the problems of traffic and parking are likely to prove merely stop-gap measures, which may in fact impede rather than contribute to long range solutions. The fundamental need is for control of the density of land-use through effective city planning and zoning."

Land costs as compared to re-use values are discussed, and both the analysis of the reasons for the discrepancy and proposals for remedy are sound. Sound, that is, in theory, and probably effective if put into practice. But in order to put them into practice a wholly different climate towards vested property interest must come about. That there have been great changes in this since the Depression is certainly true, but we still have a long way to go.

Colean sums up much of what planners have been saying for a long time, but he, no more than they, resolves "if this were to be done" into a non-conditioned assumption. This is not a criticism, because no one could do it; and no one that I know of has done a better job of putting together the inter-relationships of all the factors. I particularly liked, too, the emphasis he puts on the "Need for Clear Objective":

"Knowing what we want before we
(Continued on page 270)

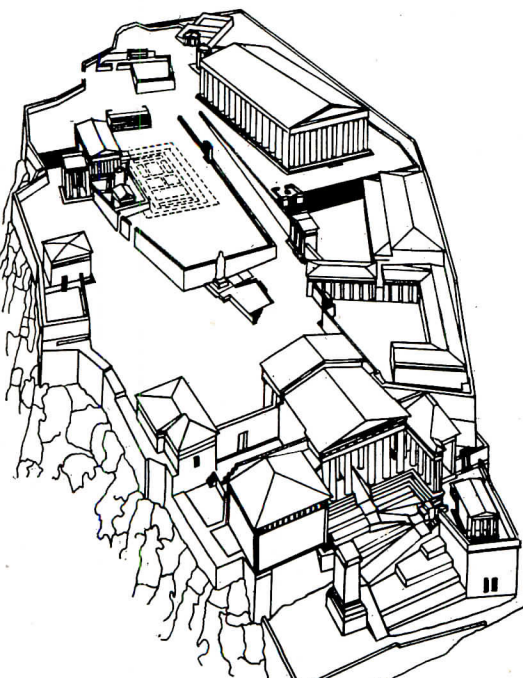

Reconstruction of the Acropolis at Athens (after Stevens). *The City of Man.* By C. Tunnard.

ON CITY PLANNING

The City of Man. By Christopher Tunnard. Charles Scribner's Sons (597 Fifth Ave., New York, N. Y.) 1953. 6¼ by 9¼ in. 424 pp., illus. \$8.50.

REVIEWED BY FRANK G. LOPEZ, A.I.A.

REVIEWING such a book as this is not a simple task. Something of lesser scope can be tossed off easily; this requires careful reading and evaluation. When, a few weeks ago, I said something of the sort to Chris Tunnard, he replied modestly that no one should have to read his work that thoroughly; and curiously enough his passing remark seems to me true of certain parts. However, nothing in the index nor on the jacket tells one what to study and what to gloss.

"The City of Man" is not the first statement of the importance of civic beauty, but it is a modern and a forceful one. In its entirety it focuses on the need for what Tunnard calls "three-

dimensional" planning (though so many more elements than the purely physical are encompassed in his full definition that it might be called six- or seven-dimensional!) and on the necessity for a true planner to be a visual artist. With this no architect will quarrel, certainly, though it may seem to relegate to secondary importance the feel of life or the sense of confluent purposes — to say nothing of civic government, the smells of the city, or the little personal activities which in sum constitute social mores. Actually Tunnard does consider all these important; he reviews them all and fits them all neatly into a total view of the new planner's functions and potential achievements. The scope of the book, you see, is truly great.

At the same time, it is also focussed on problems that are peculiarly American
(Continued on page 48)

Rolling Steel Doors

Manually, Mechanically, or Electrically Operated

An electrically operated rolling steel door meets present-day requirements more fully than any other type of door. The quick-opening, quick-closing, vertical roll-up action of a rolling steel door requires no usable space either inside or outside the door opening . . . there are no overhead tracks or other obstructions to interfere with crane operations—materials can be stacked within a few inches of the door curtain on either side. No other type of door offers these inherent advantages of space economy and compactness in operation . . . in addition, rolling steel doors are permanent—their all-metal construction assures a lifetime of trouble-free service and maximum protection against intrusion and fire. When you select a rolling steel door, check specifications carefully . . . you will find many extra-value features in Mahon doors—for instance, the galvanized steel material, from which the interlocking curtain slats are rolled, is chemically cleaned, phosphated, and treated with a chromic acid solution to provide paint bond, and, the protective coating of synthetic enamel is baked on at 350° F. prior to roll-forming. You will find other materials and design features in Mahon doors that add up to a greater over-all dollar value. See Sweet's Files for complete information including Specifications, or write for Catalog G-54.

THE R. C. MAHON COMPANY

Detroit 34, Michigan • Chicago 4, Illinois • Representatives in all Principal Cities
 Manufacturers of Rolling Steel Doors, Grilles, and Automatic Closing Underwriters' Labeled
 Rolling Steel Doors and Fire Shutters; Insulated Metal Walls and Wall Panels;
 Steel Deck for Roofs, Partitions, and Permanent Concrete Floor Forms.

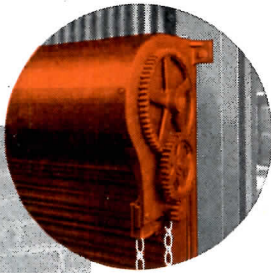

**MAHON
CHAIN-GEAR
OPERATOR**

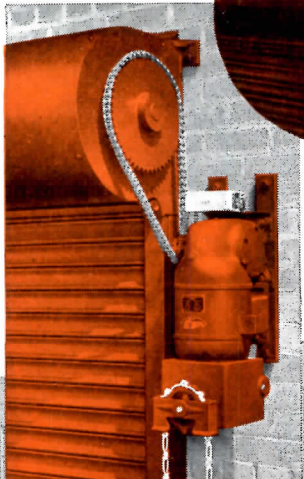

**MAHON STANDARD
POWER OPERATOR 920-P**

Two Special Power Operators are also available to meet unusual requirements including JIC Stds.

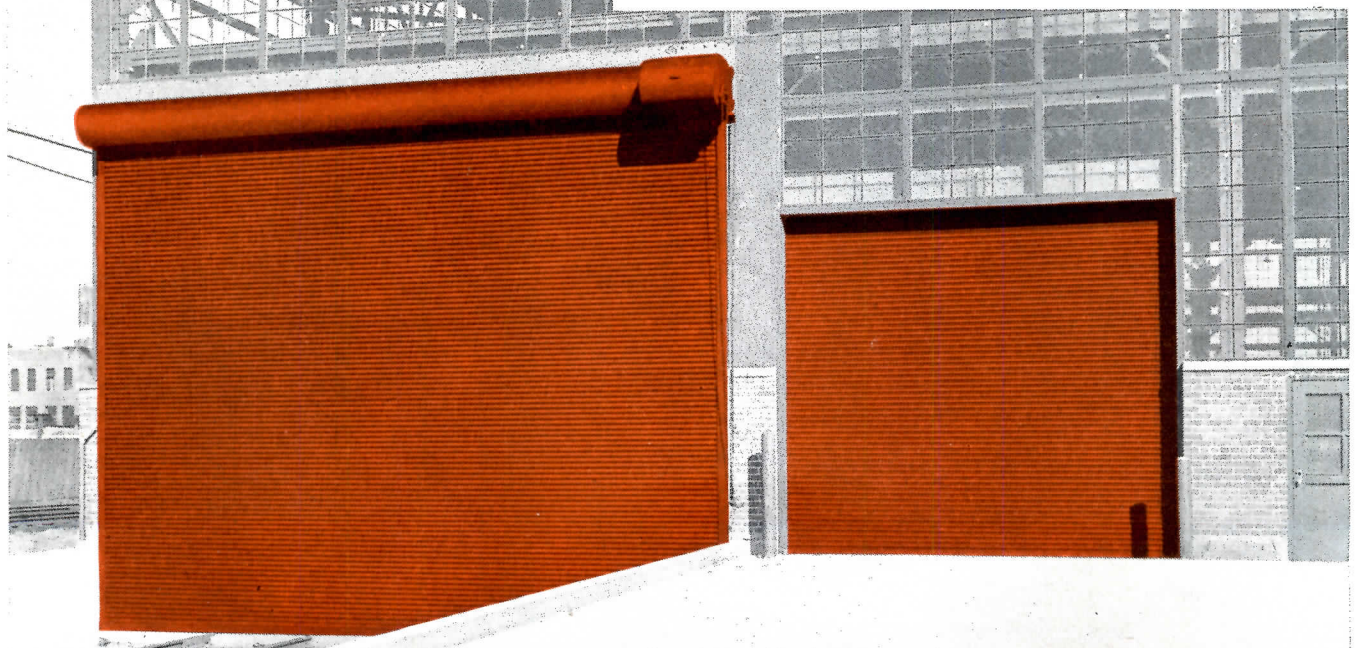

ROLLING STEEL DOORS, SHUTTERS AND GRILLES TO MEET EVERY REQUIREMENT

MAHON

OUT OF THE "BUFFALO" PUNISHMENT PIT—

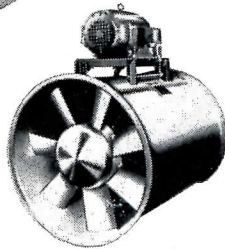
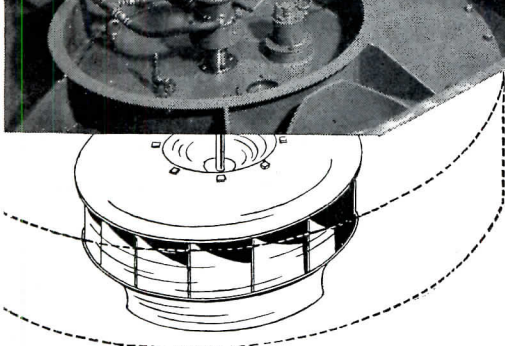
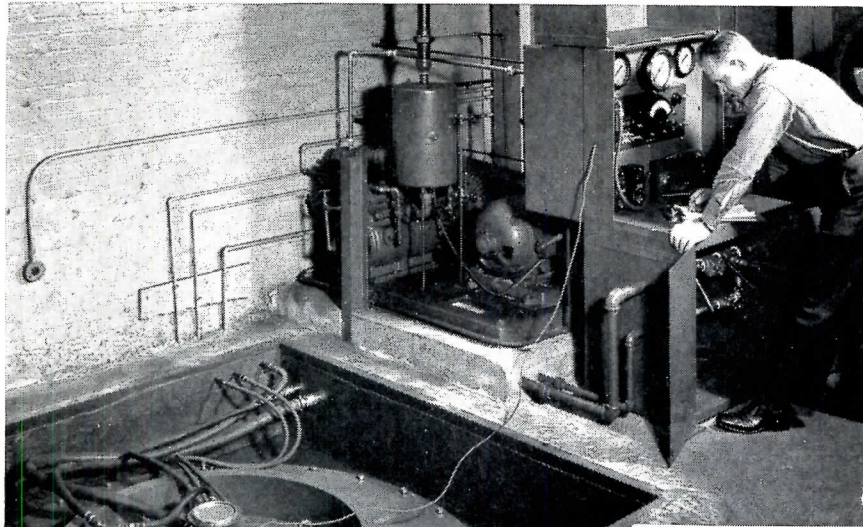

"Buffalo"
Axial Flow Fan

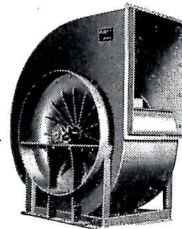

"Buffalo"
Type "BL"
Limit Load
Ventilating Fan

COME BETTER FANS FOR YOU

To be sure that "Buffalo" high-speed rotors can stand far greater stress than they would ever encounter in an installation, we deliberately try to destroy them in this "Buffalo" vacuum test pit! Here, in a partial vacuum, the rotor to be tested can be revolved at top speeds as high as 60,000 and even 70,000 feet per minute. The slightest unbalance, the slightest structural weakness, would result in destruction of the rotor at these fantastic speeds — and it shows up here in the Punishment Pit, not in the installed fan.

This is just one phase of the rigid testing and excellence of engineering, or "Q" Factor*, which assures you of a best buy when you specify "Buffalo" Fans. Why not write for "Buffalo" engineering literature on *your* air handling problem?

* The "Q" Factor — The built-in Quality which provides trouble-free satisfaction and long life

"Buffalo"

BUFFALO FORGE COMPANY

145 Mortimer St. Buffalo, New York

PUBLISHERS OF "FAN ENGINEERING" HANDBOOK

Canadian Blower & Forge Co., Ltd., Kitchener, Ont.
Sales Representatives in All Principal Cities

VENTILATING PRESSURE BLOWING COOLING HEATING FORCED DRAFT
AIR CLEANING AIR TEMPERING INDUCED DRAFT EXHAUSTING

REQUIRED READING

(Continued from page 46)

ican. His city is Everywhere, U. S. A. He writes of Paris and Venice and Amsterdam as forerunners whose influence is felt here and as lessons to be studied profitably; some of them he calls dead cities which are still with us. He portrays the Continental military encampment as a prototype for some colonial plans, reports the work of earlier European and American planners, and rushes on to the future of planning for an industrial civilization in a super-mechanical, not to say mechanistic, age, and I suspect he concentrates on the American scene because he believes that age is to be fully realized here. We have often told ourselves that, and we have been told it by many professional men from abroad. We seem to be able to take the assumption somewhat in stride though unable to make it produce beauty — except occasionally. To Tunnard, born in Canada and transplanted early to England before landing permanently here, the assumption has continuous importance and our exceptions should become the rule.

Thus the sociologist, the statistician, the engineer and to a limited extent the politician, the traffic man and (far more important though he is considered) the architect all become technicians, each contributing to the total civic design. The guiding spirit is to be the creative designer who assembles the contributions into a whole that is more than merely salutary. Because architects face exactly this problem every day, Tunnard emphasizes their importance; he also understands that urban buildings are a large part of the visual effect the city has on man. In fact, the book contains an entire chapter on the coming revolution in architecture which is bound to appeal to contemporary architects.

Yet this identical chapter is one of the weakest. (Perhaps the engineer will so consider the references to engineering and the sociologist the discussions of the social basis of urban esthetics!) Without detailed discussion the charge is difficult to support, for the chapter does homage to the current passion among architects for humanism, ornament, ensemble, proportion and scale. Very little attention is paid to such contemporary factors as the search for a true architectural economy, as much of means as of dollars; or the

(Continued on page 270)



Joseph W. Mellitor

CARNEGIE ENDOWMENT FOR INTERNATIONAL PEACE

INTERNATIONAL CENTER, NEW YORK, N. Y.

*Harrison & Abramovitz, Goldstone & Abbe, Architects | James
Dawson, Supervising Engineer | Severud-Elstad-Krueger,
Structural Engineers | Syska & Hennessy, Mechanical and
Electrical Engineers | Caudwell-Wingate, General Contractors*

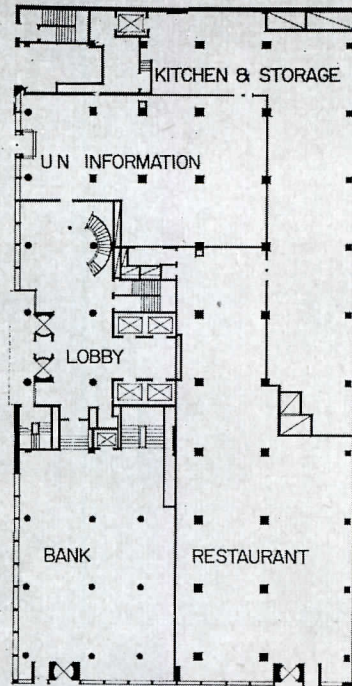
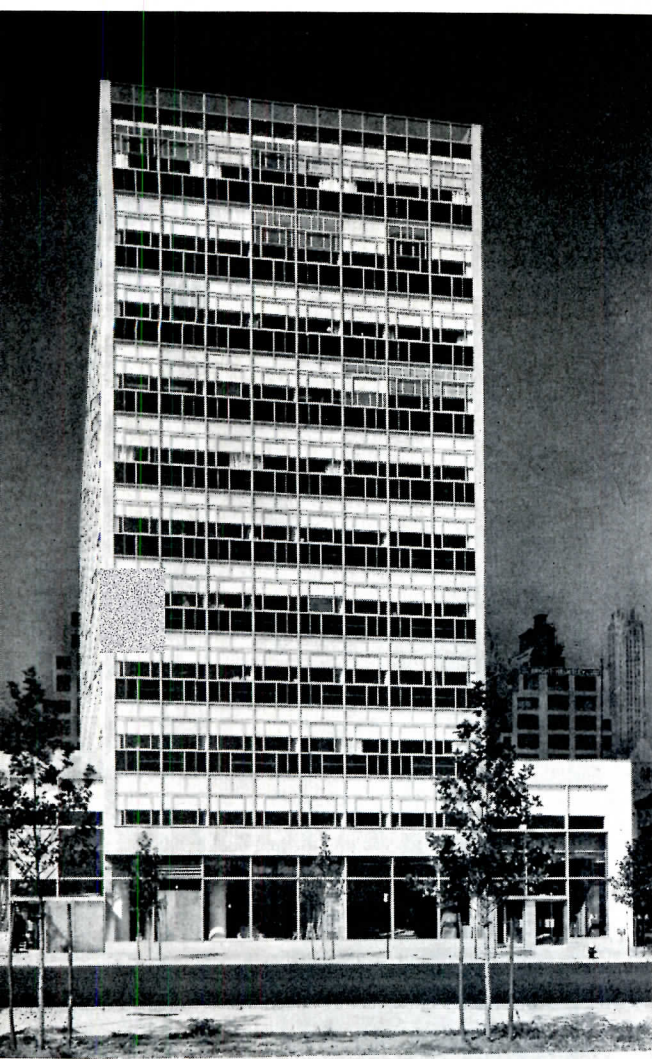

GROUND FLOOR.
0 10 20 40 60 FT.

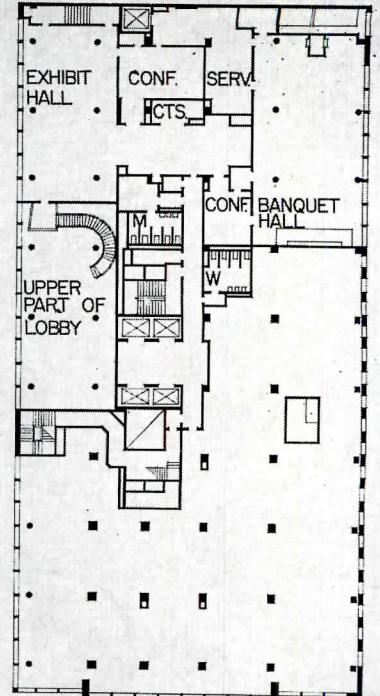

SECOND FLOOR

**ORGANIZATIONS IN THE
CARNEGIE ENDOWMENT
INTERNATIONAL CENTER**

- The Jane Addams Peace Association
- Committee for World Development and World Disarmament, and Observer to the United Nations
- American Association for the United Nations, Inc.
- American Friends Service Committee, Inc.
- The United Nations Program
- The American Heritage Foundation
- The American-Korean Foundation
- Association for the Aid of Crippled Children
- Board on World Peace of the Methodist Church
- Carnegie Endowment for International Peace
- Child Welfare League of America, Inc.
- Citizens Conference on International Economic Union
- Committee for Free Asia
- Community Chests and Councils of America, Inc.
- Council on Social Work Education
- Educational Film Library Association, Inc.
- Film Council of America
- Foreign Policy Association
- The Girls' Friendly Society of the U. S. A.
- Guideposts
- Information Center for the United Nations
- Women United for the United Nations
- International Conference of Social Work
- International Development Placement Association
- The International Film Foundation
- International Labour Organisation
- Liaison Office with the United Nations
- International Social Service
- Life Insurance Medical Research Fund
- The Lucius N. Littauer Foundation
- National Conference of Social Work
- National Council of Women of the U. S., Inc.
- National Recreation Association
- National Social Welfare Assembly, Inc.
- The Royal Institute of International Affairs
- New York Publications Office
- Save the Children Federation
- Unitarian Service Committee, Inc.
- United Community Defense Services, Inc.
- United Defense Fund
- United Housing Foundation
- The World Medical Association
- World Veterans Fund, Inc.

The Carnegie Endowment's International Center, as we reported in June 1952, is headquarters for a number of international yet non-governmental agencies. The Endowment's offices are on the eleventh and penthouse floors; ground floor is mostly commercially rentable space; other organizations occupy remaining floors

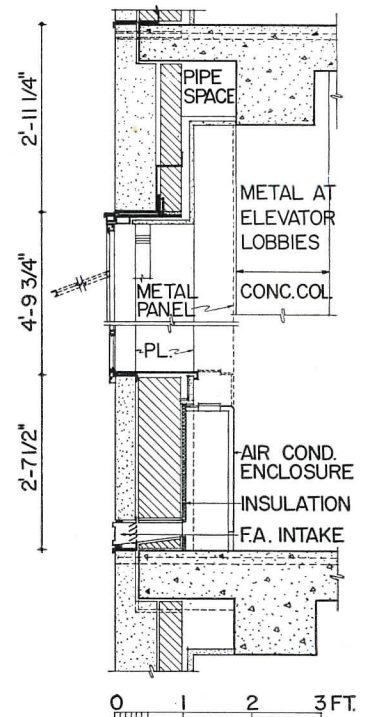
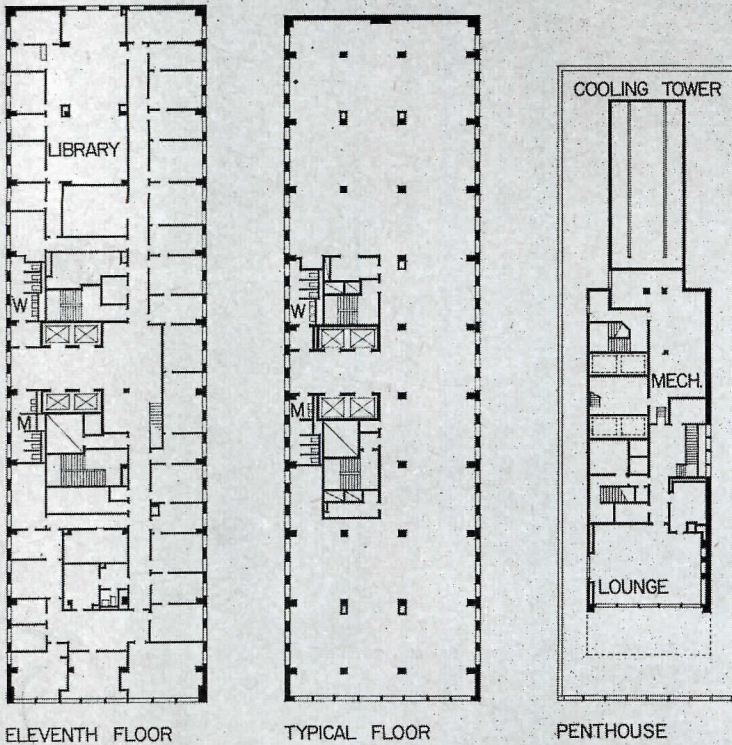
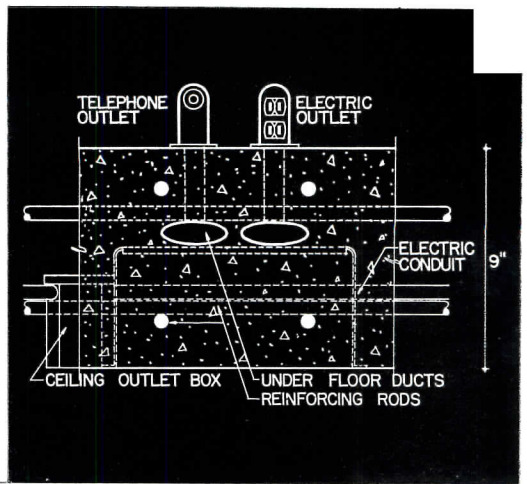

None of the organizations, including the Endowment, could allocate an undue amount of money for rental for quarters. Hence the economical combination of reinforced concrete and steel frame, the services incorporated in the 9-in.-thick floor slab, absence of furring or cinder fill (which, with low ceilings, cut total height enough to permit 11 stories in normal 10-story height) and masonry walls on the north and south façades



INTERNATIONAL CENTER

Second floor contains meeting rooms used by all the organizations, often in conjunction with U. N. activities. Exhibition hall, below, serves also for meetings and as a lounge. Interiors, designed by Knoll Associates as consultants to the architects, employ standard furniture, a few special pieces, strong color, textured fabrics, and contemporary paintings (see succeeding pages).



Exhibition hall, above, is reached directly by stair from entrance lobby, right. Characteristic of both rooms is a feeling of simplicity and dignity; yet both have a personal quality which emphasizes the concern of the many organizations in the Center with human affairs. On facing page, top to bottom: typical offices of the Endowment and of the Foreign Policy Association, and the Endowment's reference library.



The east façade of the Carnegie Endowment International Center recalls the U. N. Secretariat nearby; north and south walls, however, are masonry pierced by conventional windows and fresh air intakes for the unit air conditioners, one per bay on each floor. Solid walls on these two faces cut the air conditioning load and proved cheaper to build, in this instance, than metal-and-glass walls. The unit conditioners were necessary because low story heights made it inadvisable to fur down ceilings to cover the ductwork which a central-supply air conditioning system would have required.

Two photos at right show typical office space. At top is an Endowment office, opening from a conventional corridor. Other photo, in quarters of the Foreign Policy Association on a lower floor, uses a wider corridor in which are cubicles for secretaries; these are separated by low acoustical partitions. Private offices reached through them are somewhat smaller though quite suitable for routine purposes.



Joseph W. Molitor



ARCHITECTURAL INTERIORS

Design | *Details* | *Materials* | *Equipment*

INTERIOR DESIGN BY A CONSULTANT

Knoll Associates Planning Unit, Interior Design Consultants

A MORE UNIFIED CONCEPT results when the interior of a building is carried to completion under the architect's direction, rather than by others working independently with the owner. In addition, the architect thereby both widens his area of activity and adds to his income. Historically, interiors have been the concern of the architect, and only in comparatively modern times have they been done by others.

One architect will tell you he does interior work and that it turns a profit; another will say it is time consuming and thus a money loser for his office. A possible answer for the latter lies in the hiring of a competent interior design consultant, one who understands the architect's approach and who has a technical background. By this procedure, the architect retains control, receives a nominal administrative fee, and an integrated design results.

Such was the method followed in the design for the International Center interiors, and the result is both distinguished and a source of gratification to all concerned. Without sacrificing the needs of the building's "working areas" and yet economizing in every aspect of their execution, the architect and the Knoll Associates Planning Unit created a luxurious penthouse lounge and at the same time held total cost to the budget figure. It was designed as a "special room for special functions" and the interior consultant was able to give this area the dignity demanded by its United Nations surroundings.

For the interior design plan of the building, there were two major problems; that of flexibility in the use of space, and that of economy.

In terms of plan, the functions of the spaces are divided into two categories: (1) Administration for the Carnegie Foundation, principal occupant, which includes executive offices, library, general offices; and (2) conference and assembly areas for all tenants for group meetings which are carried on continuously during the day and evening. The problem was further extended when the clients stated they did not know exactly what demands on space would be made when they moved into new quarters.

In both the administrative and conference areas, the two problems of economy and "unknown" degree of flexibility were met by the use of strong color, the selection of adaptable furniture, and the specification

of long wearing finishes and fabrics. Color is used to create two effects: first, to enliven spaces and make them attractive and friendly; second, and more important, to keep a given area intact when the space within is disrupted. In order to hold each area together, one strong color is applied to one or possibly two walls while the remainder of the space is kept neutral or natural in tone.

Furniture throughout can be moved about easily into



large or small groups for flexibility. Color selection of furniture coverings is such that in the moving of furniture from one room to another, color schemes never clash. The variety in color provides an overall continuity throughout all of the offices and lounges, and at the same time keeps areas alive with its ever changing combinations. In the larger lounges, a few purposely heavy pieces are selected to maintain the basic room scheme. Because of the heavy duty demanded, all surfaces are made of practical materials. Table tops are of stain- and burn-resistant plastic laminates in black, white or wood grain, or of marble; fabrics are selected for easy maintenance and long wearing qualities. In the administrative areas, space is at a premium and scale is of great importance. Because of the changing quality of the functions within each office, furniture was chosen for adaptability. In many offices, furniture is arranged so that the office can also be used as a meeting room. Privacy for two persons within a small office is created by free standing book-case partitions.

THE CARNEGIE INTERNATIONAL CENTER

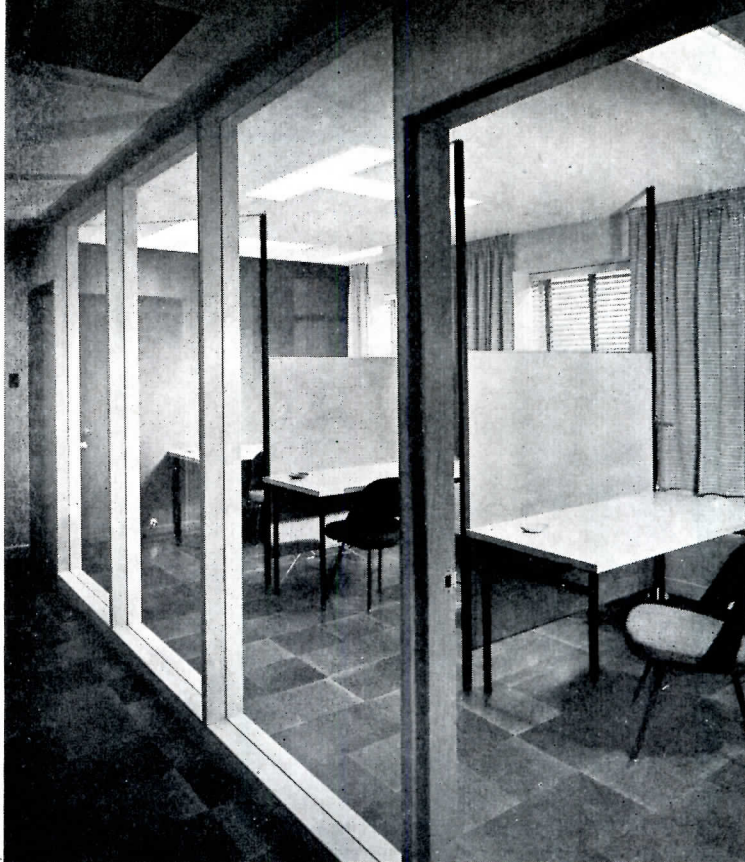

Joseph W. Mellitor

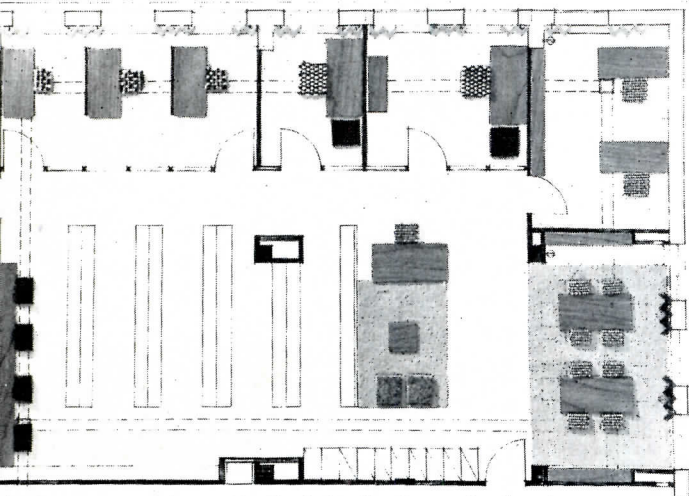

Three photos and plan show library areas, in which typical walls are off-white, accent walls yellow, curtains yellow on white, chairs blue-green. Research study units, above, are defined by pandanus cloth covered panels on black painted channels; vermilion chairs add interest. Student work space, below, features birch light baffle and long desk where several may study



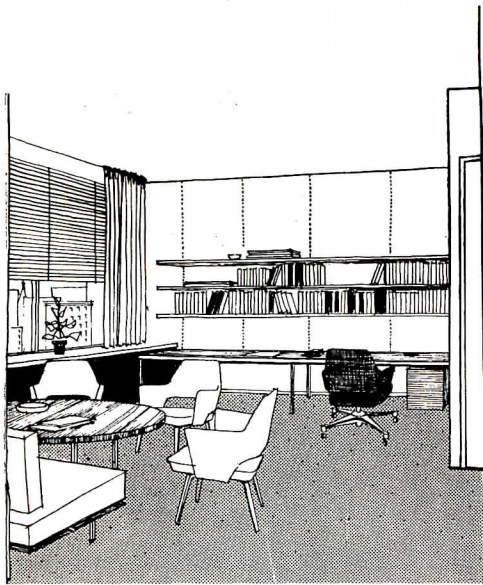

THE CARNEGIE INTERNATIONAL CENTER

ARCHITECTURAL INTERIORS

Design | Details | Materials | Equipment

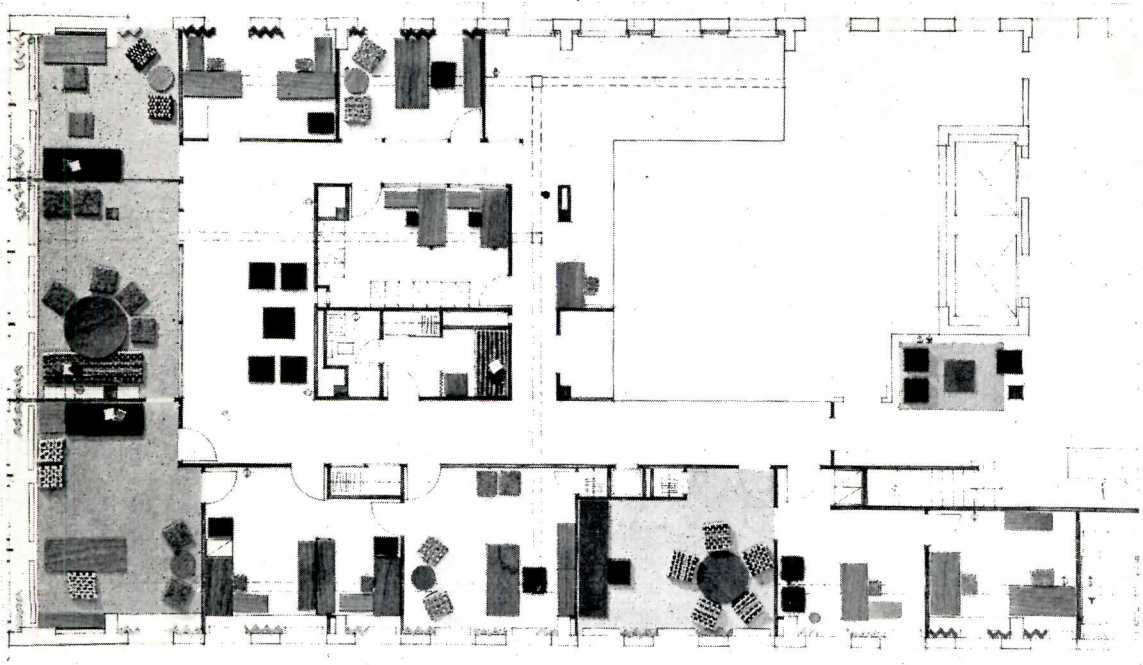

Joseph W. Mellor

Top sketch shows office which provides a conference area. Typical floor plans were arranged for specific needs. Left, typical two secretary office

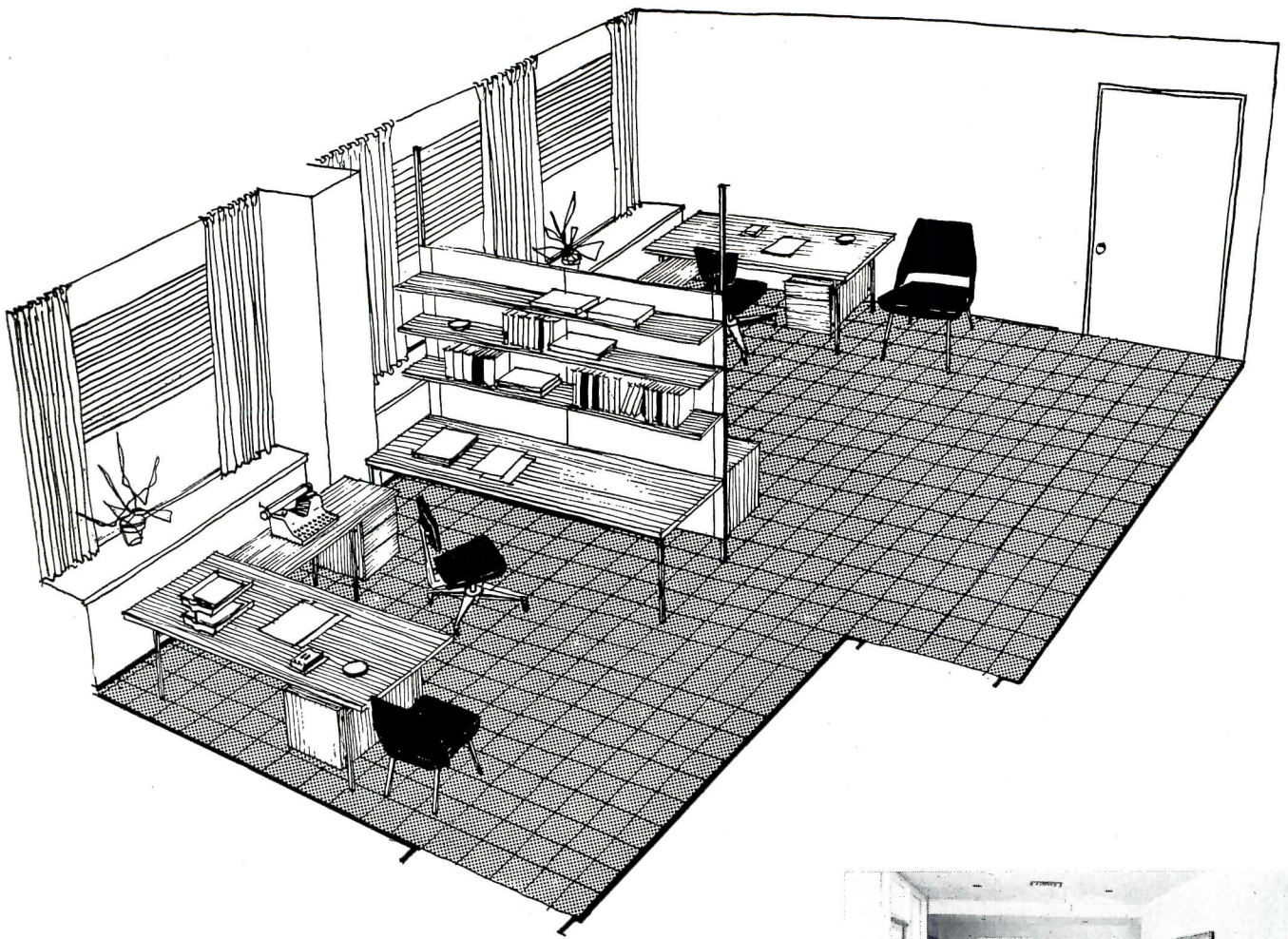

Multiple use office shown at top; adjustable shelves on painted wood panels secured to steel channels. Photos show director's office and adjoining reception area created by widening corridor



ARCHITECTURAL INTERIORS

Design | Details | Materials | Equipment

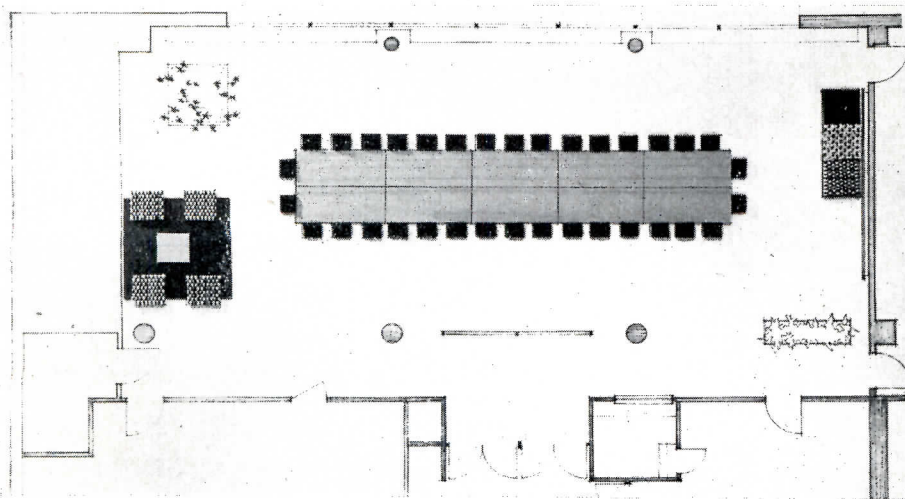
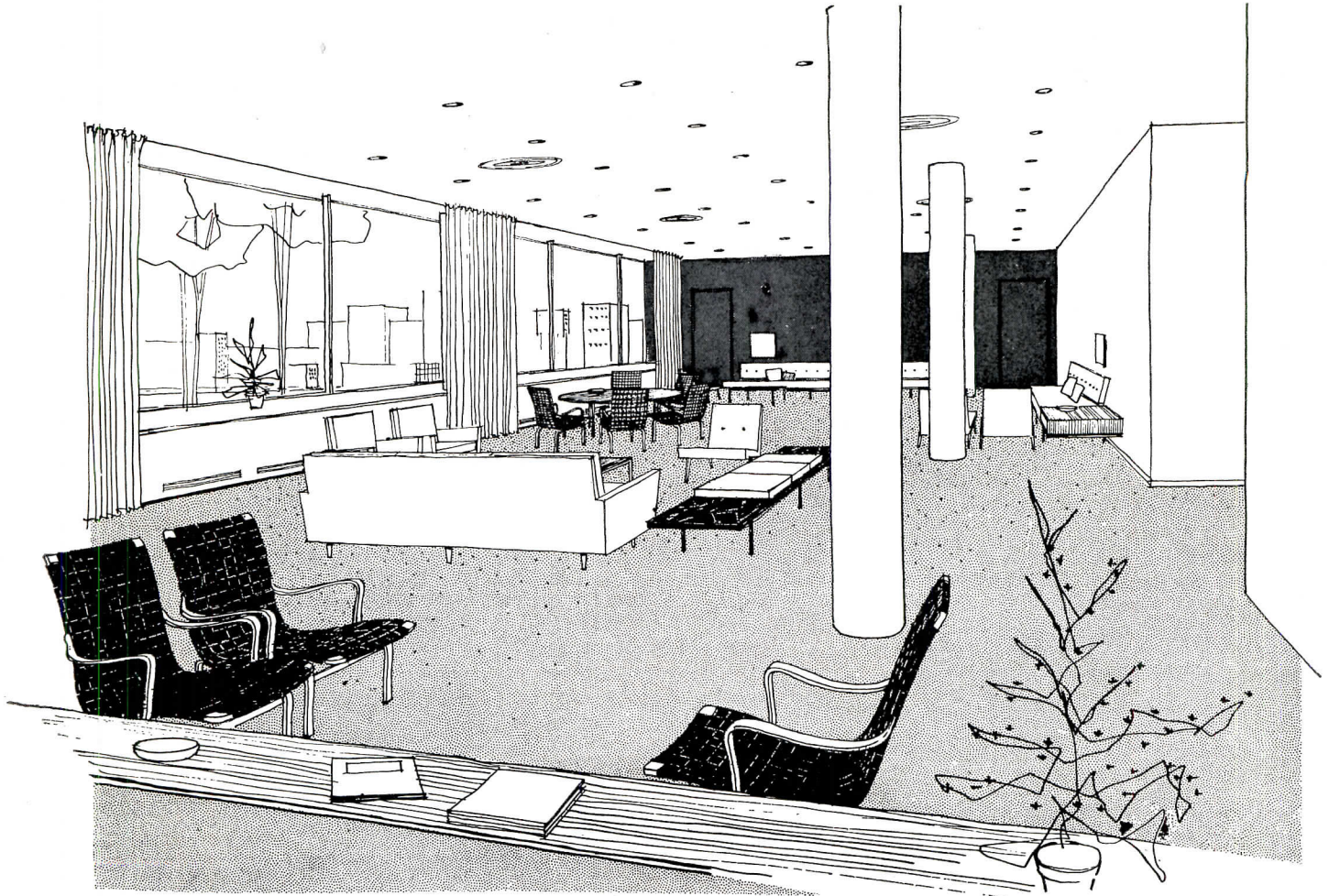

A heavy, natural, textured curtain material minimizes window columns in second floor lounge and exhibit area, illustrated on this page. Color scheme: sand carpet; gray or pandanus walls with vermillion end wall; black or black and white on furniture; accents of yellow chrome, blue ultramarine and vermillion

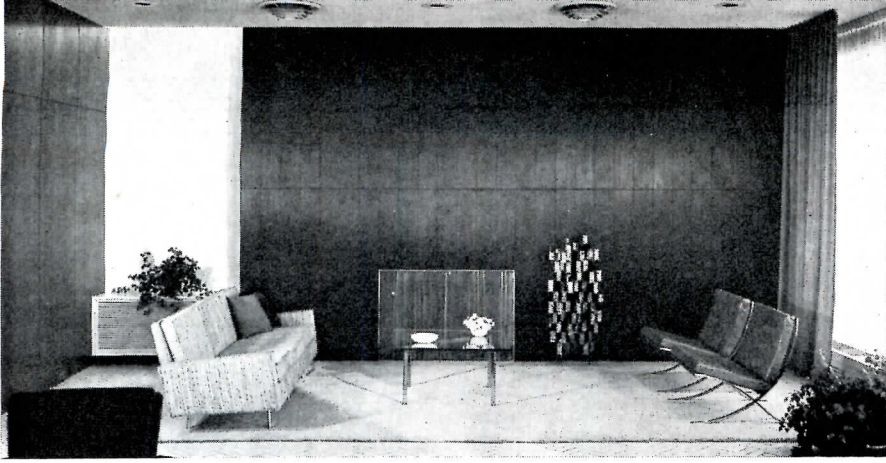

In the penthouse lounge, this page, use of material and color is important. Floor is speckled white glazed brick; walls are white plaster, natural cherry or ebonized wood in unbroken rectangles; stainless steel furniture with natural leather or hemp and white wool upholstery; golden yellow curtains; orange, yellow and black cushions

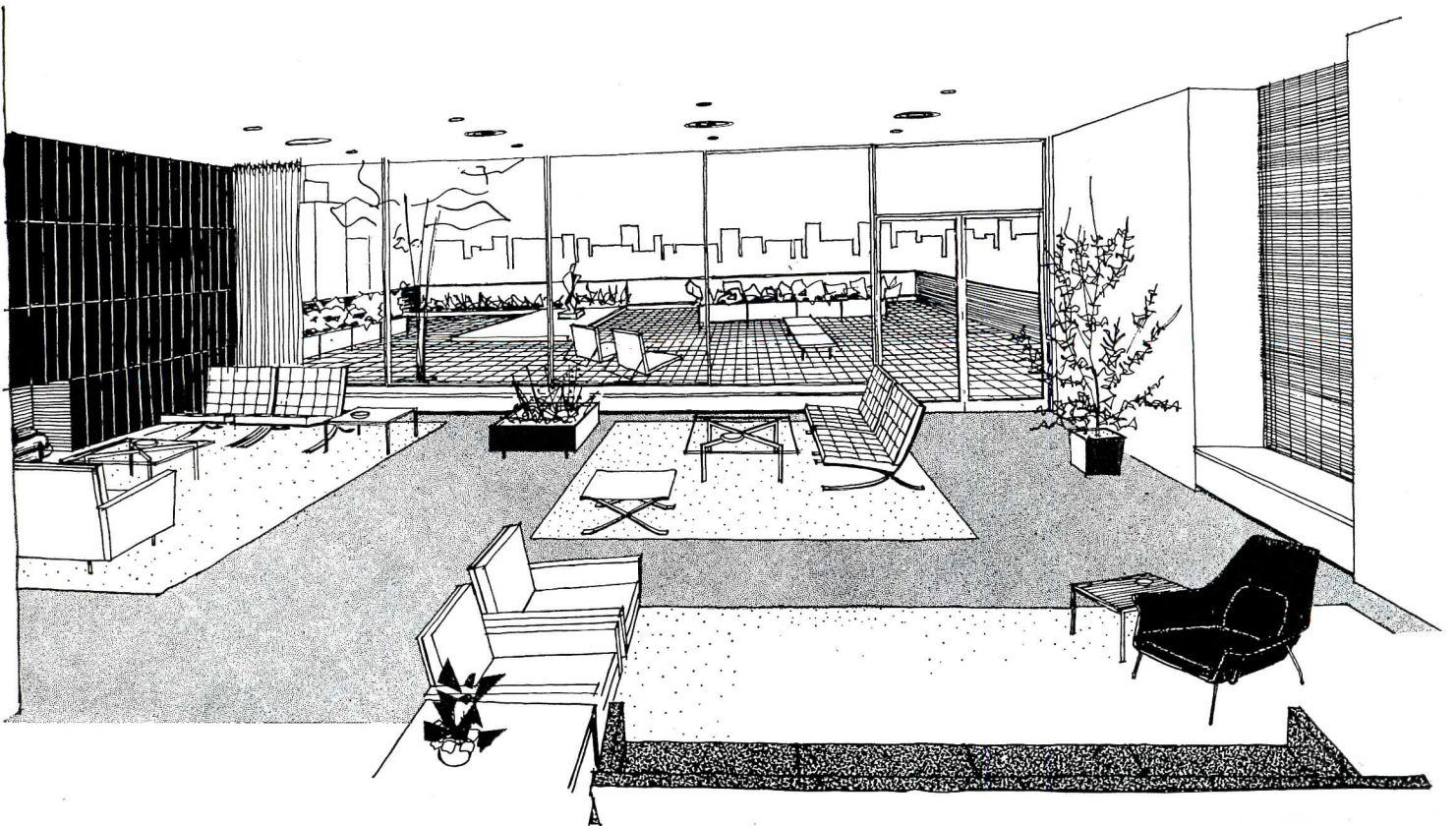
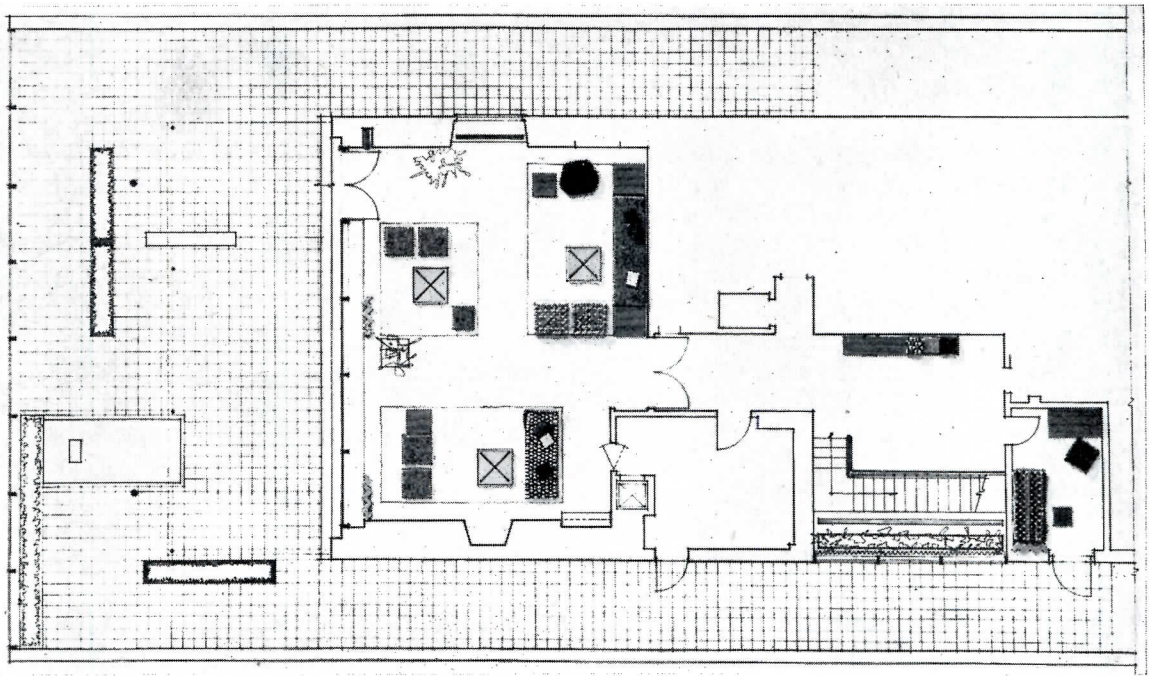

THE STATE OF CONTEMPORARY ARCHITECTURE

BY SIGFRIED GIEDION

I. | THE REGIONAL APPROACH

THE state of contemporary architecture today is such that a historian is compelled to refer back to points that, one could have thought, had been made abundantly clear many years ago. But during recent years the origins of contemporary architecture, and indeed its very nature, have again become clouded and confused. No single country, no single movement, no single personality can be claimed to explain the coming about of contemporary architecture. Trends shuttle to and fro, from one country, one movement, one personality to another, and become woven into a subtle pattern that portrays the emotional expression of the period.

There is a word that we refrain from using to describe contemporary art. This is the word "style." In a primitive sense the word "stylus" was used even in Roman times to describe different manners of writing, but "style" did not come into general use to describe specific periods until the 19th century, when different periods of architecture were analyzed according to a materialistic description of details of form. Today, the moment we fence architecture in within a notion of "style" we open the door to a purely formalistic approach. Purely formalist comparisons have about the same effect on the history of art as a bulldozer upon a flower garden. Everything becomes flattened into nothingness, and the underlying roots are destroyed.

The architect of today regards himself not merely as the builder of an edifice, but also as a builder of contemporary life. In other words the architect of today refuses to consider himself a mere *confiseur* (pastry-cook) employed to attach some trimmings within and without after the structure has been delivered to him by the engineer. No, the architect has himself to conceive it as an integrated whole. Like all real artists, he has to realize in advance the main emotional needs of his fellow citizens, long before they themselves are aware of them. A wholeness, a togetherness of approach, has become a "must" for any creative spirit.

All this is involved in the reason why we today abstain from labelling the contemporary movement with the word "style." It is no "style" in the 19th century meaning of form characterization. It is an approach to the life that slumbers unconsciously within our contemporaries.

It seems — and this cannot be too often repeated — that all creative efforts in contemporary art have, as their common denominator, a new conception of space; and this is so no matter how different the movements themselves may appear from one another. This new representation of space contrasts fundamentally with the Renaissance perspective and the consequences that developed from its single focal point.

It has been stated over and over again — indeed I have said it myself — that it is the plane, which earlier had lacked any emotional content, that has become the constituent element of our new representation. Furthermore there is no doubt that the use of the plane as a means of expression was evolved from cubism between 1910 and 1914. On two pages of *Space, Time & Architecture* (page 362–363) I tried to show how the same spirit emerged in several different countries, by presenting a visual comparison of a collage by Braque (fig. 1), a painting by Mondrian (fig. 3), an architectural study by Malewich (fig. 2), a country house by van Doesburg and van Eesteren, and Gropius' Bauhaus.

The art magazines have recently been stressing that "the right angle and primary colors used with black, white and gray, disposed in an asymmetrical arrangement" were the basic elements of "de Stijl." This factual analysis is perfectly correct as far as it goes, but it does not touch the reason behind the use of these simple elements — the essential heart of the matter which "de Stijl" shared in common with the whole contemporary movement. This was the *introduction of the plane* as a constituent element to express the new anti-renaissance space conception. The right angle, the vertical, and — to a certain extent — the primary colors are by-products and not essential features of the modern conception.

It is well known that the "de Stijl" people around van Doesburg never formed themselves into a formal group, as for example the Futurists did. "De Stijl" consisted of various individualists working in different places. There was sometimes a certain amount of collaboration, as at one time between Doesburg and Oud, and, in the twenties, between Doesburg, the young van Eesteren and Rietveld. But on the whole they remained individualists. J. J. P. Oud (whose early accomplish-

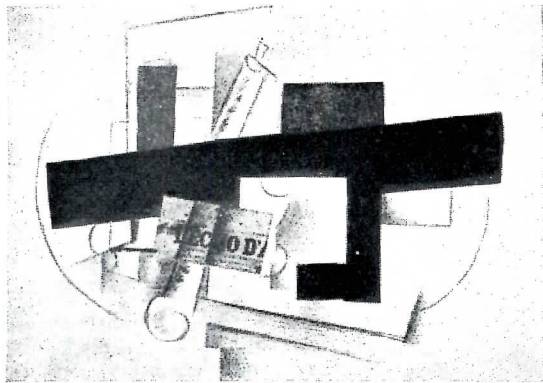

1

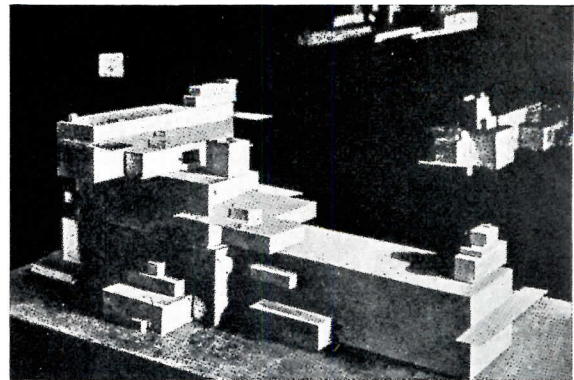

2

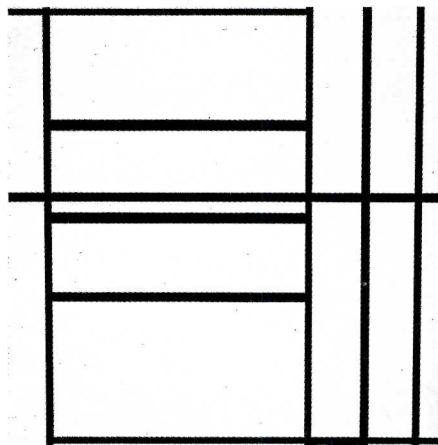

3

"... It is the plane, which earlier had lacked any emotional content, that has become the constituent element of our new representation." The author cites a collage by Braque (1), a study by Malevich (2), a painting by Mondrian (3), also the work of van Doesburg and van Eesteren (4), and Gropius' Bauhaus as important examples of the use of the plane

Giedion does not explain Mondrian's paintings as representations of Holland's tulip fields, but he does maintain that "the organized plane surface is in no other country so prevalent" as in Holland, as witness the early painting of a Dutch interior by Pieter de Hooch (5) and a tulip field (6) — or a hyacinth field as actually shown

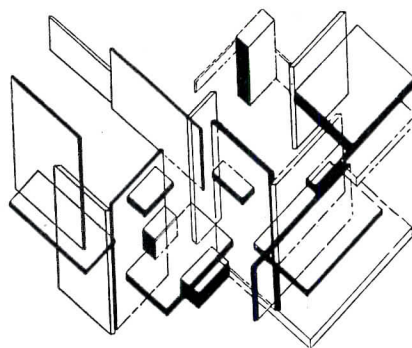

4



5



6

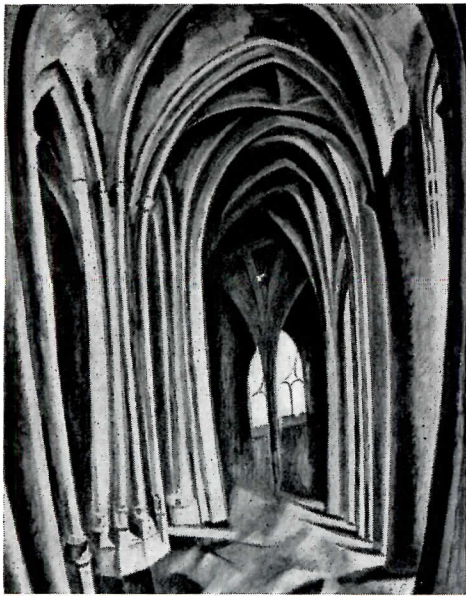

7

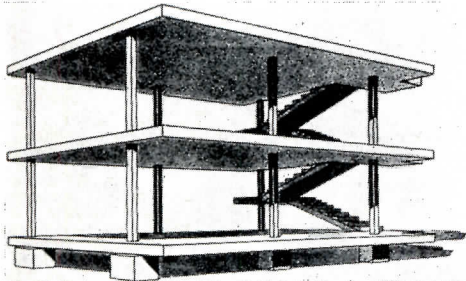

8

France's contributions to the chain come from another source — a great eagerness to experiment with new forms of structure, as witness the Halle des Machines or the Eiffel Tower. "... here it is interesting to note that the painter Delaunay (a representative of the so-called 'orphic cubism') was first inspired by Gothic churches." (S. Severin 1909, fig. 7.) Le Corbusier's first sketches of the ferroconcrete skeleton for the House Domino was also "revealing" in this respect (8)

ments will always form part of the history of architecture) is typical of these individualists. When I met him for the first time in 1926 he even then emphasized "I was never a member of 'de Stijl.'" And, in his own way, Piet Mondrian (who called his work "neo-plasticism") expressed a similar standpoint. It was indeed just this free cooperation of strong individualists, often in dissension with one another, that gave the Dutch movement its undeniable mental strength.

The word "style" when used for contemporary architecture is often combined with another password label. This is the epithet "international." It is quite true that for a short period in the twenties the term "international" was used, especially in Germany, as a kind of protest to differentiate contemporary architecture from "Blut and Boden" advocates who were trying to strangle at birth anything and everything imbued with a contemporary spirit. But the use of the word "international" quickly became harmful and constantly shot back like a boomerang. "International" architecture — "the international style" — so went the argument, is something that hovers in mid-air, with no roots anywhere.

All contemporary architecture worthy of the name is constantly seeking to interpret a way of life that expresses our period. If history teaches us anything it is that man has had to pass through different spiritual phases of development, just as, in prehistoric times, he had to pass through different physical stages. There are some signs that go to show that a certain cultural standard is now slowly encompassing the entire world. In historic periods cultural areas have usually been more limited in extent, but in the prehistoric era — the hundreds of thousands of years of dark ages — we find everywhere the hand axe, the *coup de poing*. This hand axe is a universal, triangular, pear-shaped tool whose



9

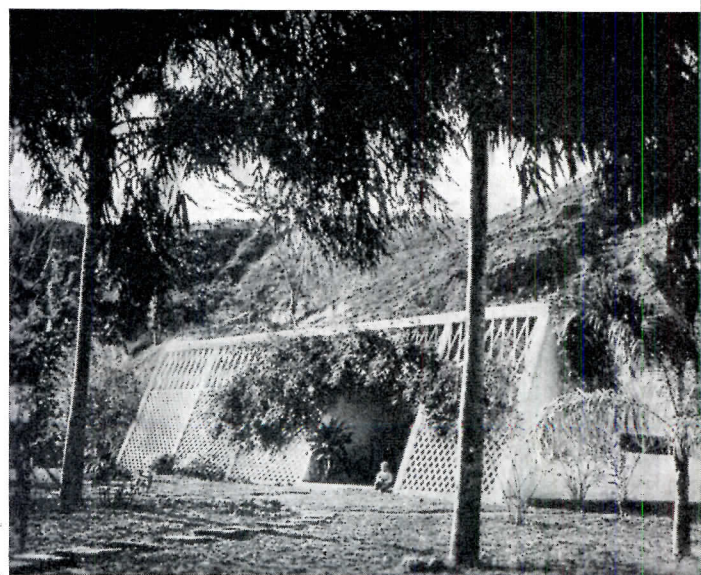

10

"In form these two houses, built by Richard S. Neutra and Oscar Niemeyer (9 and 10), have practically nothing in common, yet both are imbued with the same contemporary spirit. Formalistic analysis will not help us here"

sides slope to a fine edge. It has been found in China, in Africa, in the gravel bed of the Somme in the heart of France, in the Ohio valley. Everywhere this flint implement was shaped the same, as though the wide-flung continents had been neighboring villages.

The way of life that is now in formation is a product of the mentality of Western man. Again, as in the time of Neanderthal man, it passes round the whole world, only now the tempo is vastly accelerated and the speed has become excessive.

When I had recently to write a short foreword for a Japanese edition of *Space, Time & Architecture* I somehow felt it my duty to explain that Western man has now, very slowly, become aware of the harm he has inflicted by his interference with the way of life of other civilizations: whether it has been interference with the natural rhythms of the lives of primitive peoples, which have been the root cause of their bodily and mental persistence since prehistoric times; or whether it has been an injection of the rational Western mentality into the oldest existing civilizations, without also presenting any worthy antidote. But, even while writing this, I was obliged to add that Western civilization is itself actually in a stage of transition. Experience is slowly showing us that the rationalist and exclusively materialist attitude, upon which the latest phase of Western civilization has been grounded, is insufficient. Full realization of this fact can lead us slowly towards a new hybrid development — a cross between Western and Eastern.

Now that we no longer adhere to a creed of production for production's sake, the civilization that is now in the making draws closer to the mental outlook that is shared by primitive man and Eastern man. We in the West are again becoming conscious of something that they never forgot: that the continuity of human experience always exists alongside and in contrast to our day-to-day existence.

This may serve to strengthen a realization that the image of this emerging civilization, especially our particular interest — the form of contemporary architecture — cannot be described by so drained and bloodless a term as an "International Style." Moreover the term itself is a complete misnomer, as is the case with many other "styles." It is well known for instance that the term "Gothic Style" when used in the 18th century designated a form of barbarism. It was only after the English had rediscovered the Gothic that it became used

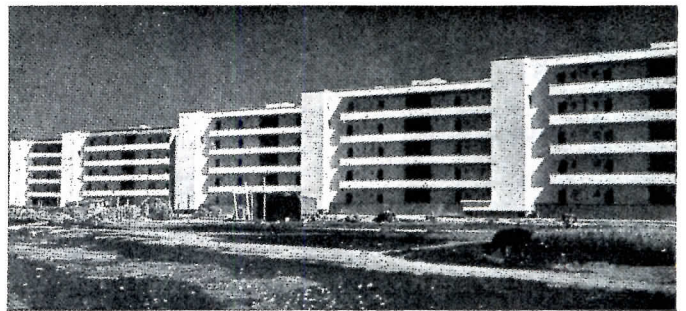

12

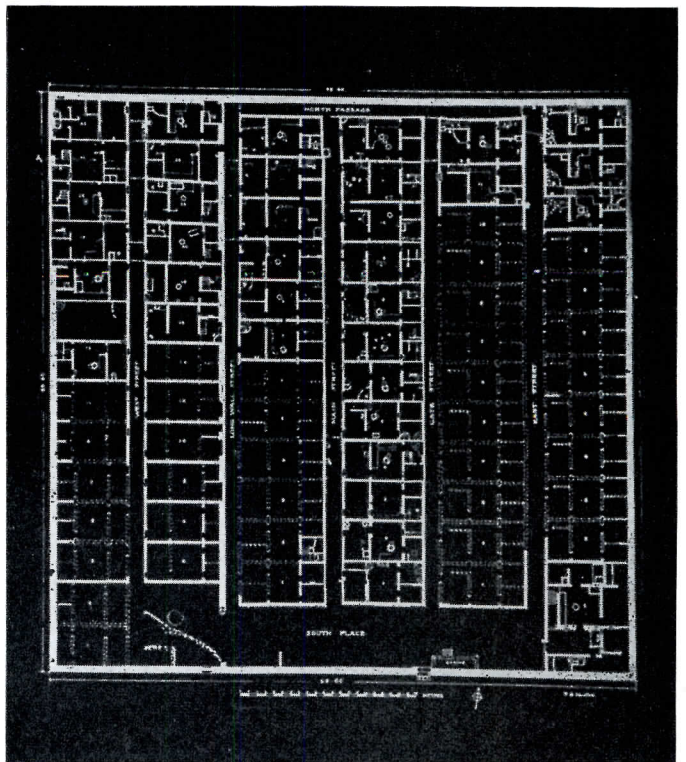

13

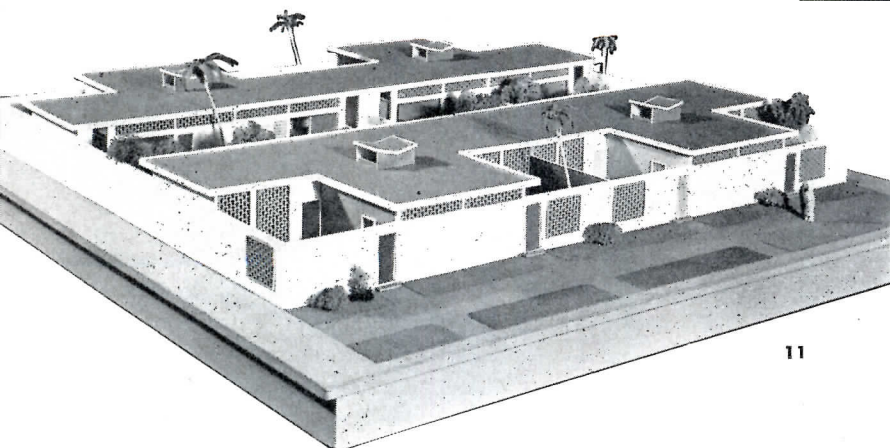

11

The "New Regional Approach." The best contemporary architects, when they have to solve a problem of building in underdeveloped areas, "strive to translate the continuity of long-established habits of life into terms of contemporary architecture." Fig. 12 shows an interesting experiment by the French Government in Morocco, recognizing habit in certain things, but still housing some groups already accustomed to city life in multistory buildings. For other groups they still use wall-enclosed row units, as in the ancient village of Tel-el-Amarna (plan in fig. 13). The walled enclosure was continued by Sert & Wiener in housing for Cuban workers (model, fig. 11)

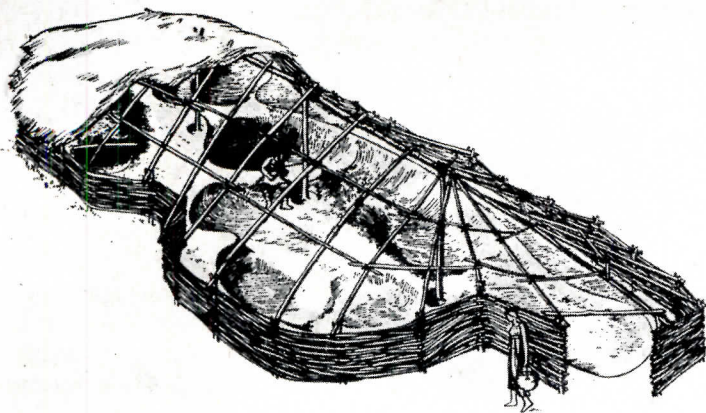

14

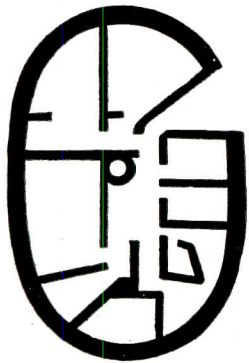

15

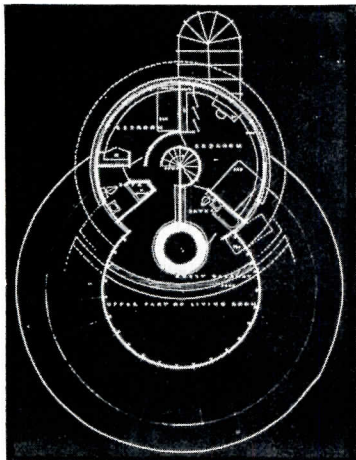

16



17

Giedion finds significance in recent departures from rectilinear house forms in the work of Frank Lloyd Wright, comparing here the plan of one Wright house (fig. 16) with the rendering of reconstructed Kurvenkomplexhütte in Koln-Lindenthal (14) and a diagram and photograph of excavations of ruins, all curvilinear as in "the first emergence of primeval architecture"

as a term of adoration. "Baroque" also was first used to describe something over-extravagant, irregular or undisciplined. But all such labels were only applied by later generations. The architects of the Gothic or Baroque periods gave no stylistic names to their buildings. They just built, as they had to build, in a contemporary manner — and so do we! So let us drop, once and for all, such misleading formalist designations.

It is true that our period, just like past periods, has a common mental outlook and a commonly recognized method of expressing its emotional content. As the outlook changes, our attitude towards our environment — the region or country in which our structures are rising — also changes. Contemporary architecture and painting are embraced by a pervading mentality — the spirit of this period. But from out the innumerable possibilities of each region, each period selects just those which correspond with, or help to express, its own specific emotional needs. Now that we are separated by several decades from the birth period of the early twenties, we are able to discern that certain regional habits and regional traditions lay concealed within the germinal nuclei of the various contemporary movements.

Two examples, one from Holland, the other from France, may serve to make this point clear. First, Holland. When we look at a painting by Mondrian or at one of van Doesburg's architectural schemes their abstract forms (Mondrian called them "neutral forms") seem very far removed from any specific regional influence. They seem so, but they are not.

At the Congress of Art Critics in Amsterdam in 1951, for which the "de Stijl" exhibition was first assembled, I was asked to speak on this movement. Rietveld, who was in the audience, sprang to his feet and sharply protested when I tried to show the inner ties that exist between Dutch tradition and these so-called "neutral forms": how, in fact, these forms are rooted in the Dutch region and in the Dutch mentality.

In the 17th century — the great age of Dutch painting — and perhaps even later, no other people laid such stress on the plane surfaces of interior walls, or of the careful organization of the position of doors and windows (Pieter de Hooch, fig. 5). Similarly one can note today the careful manner in which the Dutch gardener lays out his fields of red, white and yellow tulips (fig. 6). Certainly I would never wish this to be interpreted as though I were explaining Mondrian's paintings as reproductions of tulip fields! But I do maintain that the organized plane surface is in no other country so prevalent as here, in the region of the Polders. It is not mere chance that neither the Russians, nor the Germans, nor the French, made such use of the plane surface, framing it and extracting it from innumerable details. The plane surface, for reasons which do not need to be reiterated, is a constituent element of contemporary art: and it seems to me that van Doesburg and van Eesteren's simple drawings of the transparent interior of one of their projected houses (1922-23, fig. 4) is one of the most elucidating achievements of "de Stijl," and one

which helped enormously to clarify the mind of their contemporaries in other countries.

France's contribution comes from another source. Ever since her daring experiments in Gothic cathedrals, France has shown a great facility and a great eagerness to experiment with new forms of structure. We have only to recall the Halle des Machines or the Eiffel Tower of 1889; and here it is interesting to note that the painter Delaunay (a representative of the so-called "orphic cubism") was first inspired by Gothic churches (S. Severin, 1909, fig. 7) and later by the structure of the Eiffel Tower whose poetic content was first revealed by him and the poet Guillaume Apollinaire.

France's early and extensive use of ferroconcrete as a means of architectural conception is only one more link in the same chain. Already around 1900 Tony Garnier, in his Prix de Rome project, used the new construction method of ferroconcrete in his Cité Industrielle for all kinds of buildings. Perret soon followed with his Paris houses, garages, theaters; and one of Le Corbusier's first sketches of the ferroconcrete skeleton construction for the House Domino (1915) is as revealing as van Doesburg's sketch with its intersecting planes (figs. 8 and 4).

These are but two examples of regional contributions to a universal architectural conception. But one thing more: it has not been necessary for the architect to be a native of the country in which he is working in order to be able to express its specific conditions. We all know how Frank Lloyd Wright's Imperial Hotel in Tokyo withstood the earthquake better than Japanese structures. The reason is that the modern approach encompasses both cosmic and terrestrial considerations. It deals with eternal facts. It has been mentioned already that the aspect of the new structures may look very different from the traditional appearance of the buildings of a certain region. There is also a great apparent difference between a wide open redwood or ferroconcrete house built in the kindly homogenous climate of California and a weekend house built for the tropical conditions of Brazil (figs. 9 and 10). In form these two houses, built by Richard S. Neutra and Oscar Niemeyer, have practically nothing in common, yet both are imbued with the same contemporary spirit. Formalistic analysis will not help us here.

I would like to give a name to the method of approach employed by the best contemporary architects when they have to solve a specific regional problem — such as a building for the tropics or the West Coast, for India or for South America — whether it is for a house, a government center or a problem in urbanism. This name is the *New Regional Approach*.

I am thinking of some walk-up apartments built in Morocco by Candilis and Woods for a very poor population who now live, as in Brazil and other tropical climates, in "bidon-villes" or tin shacks made from old gasoline cans. In this case the problem was the erection of several thousand dwellings very rapidly, very cheaply and employing only the simplest techniques. Each dwell-

ing has two bedrooms that open onto a patio living room surrounded by a six ft wall that insures privacy for the family. Great care is taken to see that every corner of the dwelling is at some time penetrated by the bacteria-destroying beams of the sun. Fig. 11 shows some row houses built in Cuba by Wiener and Sert for the better paid workers. No glass is used but instead a modern version of the lattice-like openings common around the Caribbean. Each dwelling has two bedrooms and a living room that is wide open to a private patio. The neighborhood unit model for 8000 inhabitants shows how these simple units can be variously grouped.

Examples such as these imply that the modern architect should not strive to produce an external appearance in conformity with traditional buildings. Sometimes the new buildings will conform to a certain extent, sometimes they will be basically different. This difference may be due to two reasons: sometimes it will be because of new production methods and the use of new materials; sometimes, more importantly, it will be caused by the new aesthetic, the new emotional expression, that the builder is giving to the habitat of man.

The regional approach that satisfies both cosmic and terrestrial conditions is a developing trend, but there is also another symptom that is emerging, and that hints at the many-sided face of contemporary architecture. In contemporary painting many problems come forward which can also be discerned in the earliest beginnings of art. Architecture is different from painting; it is not so intimately related to man's direct projection of what flows in the subconscious mind. Yet we cannot leave unnoticed a certain symptom which has been appearing in architecture, above all in the recent work of Frank Lloyd Wright (especially since 1940). We can now follow the exciting path that the human mind had to travel before he came to standardize (if we may call it this) upon the rectangular house with its square or rectangular rooms. We are all born with this rectangular house and are so accustomed to live with it that it seems it could never have been otherwise. Yet it is important that an artist like Frank Lloyd Wright is plunging so deeply into problems that concerned the human spirit at a time when mankind was contemplating the transition from the nomadic herdsman to the settled agriculturalist.

At the very beginning of architecture the paramount type was not the square house, but the curvilinear house — sometimes round, sometimes oval, sometimes freely curving. Now it tries to make a re-appearance. Sometimes this is dictated by mechanistic reasons: such as the mast house of Buckminster Fuller, or the use of a central mechanical core. But Wright follows exclusively the line of his artistic vision, maybe adapted to the site, maybe adapted to the man who is to inhabit the house, maybe under the compulsion of expressing that which slumbers in himself. It is not my intention to discuss the pros and cons of this kind of contemporary architecture, but it seems a duty not to ignore it. What we need more today than anything else is *imagination*, but this subject must wait for a later article.

*Residence of Mr. and Mrs. Norton Polivnick
Denver, Colorado*

Norton Polivnick, Architect

Gerald F. Kessler, Landscape Architect



Marshall Brooks

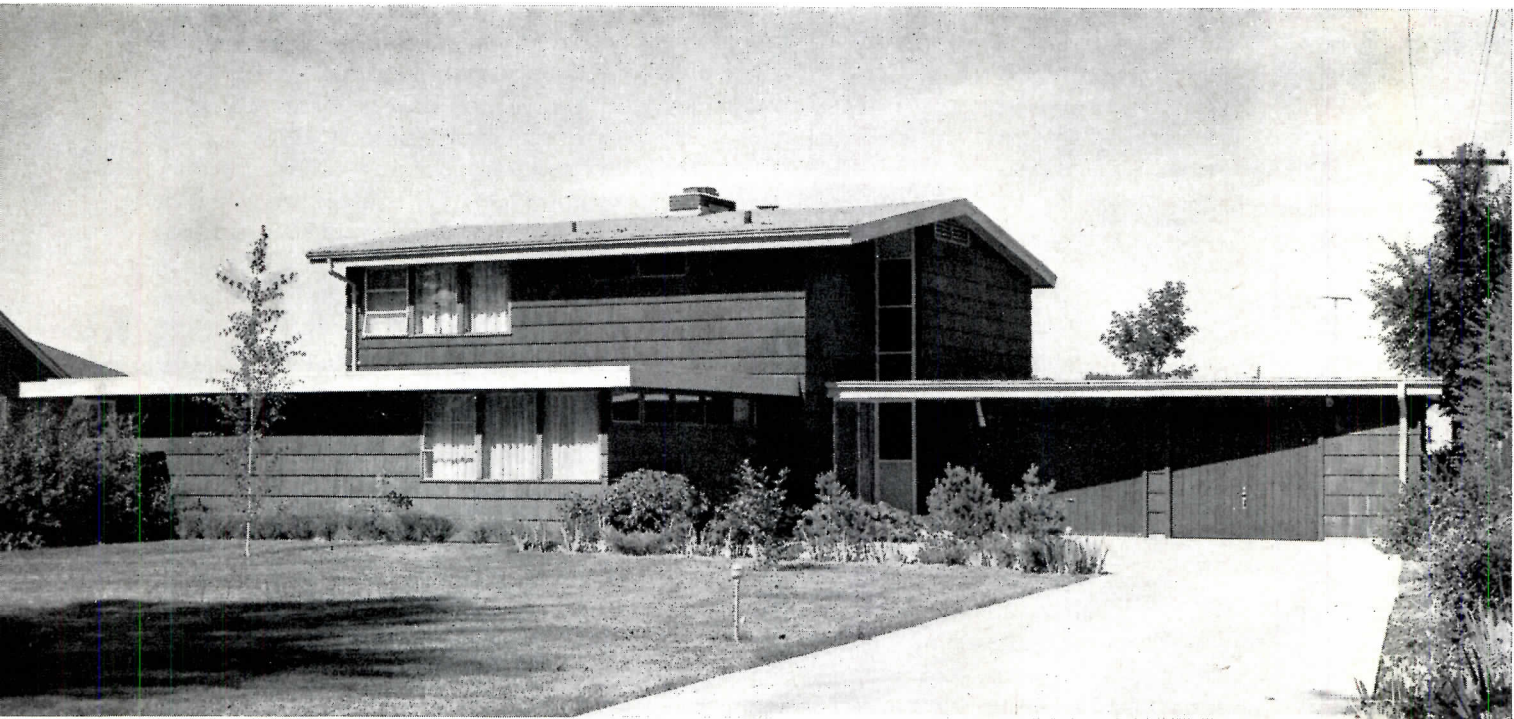

VERTICAL EXPANSION PROVES ADVANTAGEOUS



THIS HOUSE was originally designed for a family of three, with provision for guests and probable family expansion; the requirements were flexible, but the budget was not. The architect-owner based his plan on maximum use of every inch of space: the living-dining room, for instance, could be used also as a drafting room, guest room or music center; kitchen, laundry and both bedrooms were held to moderate size, and as much furniture as possible would be built in. When more room was needed, extension of the bedroom wing would be simple and economical.

Before the time for expansion had come, however, a new and large house had been built close by on the adjoining lot. The Polivnick house, with its extremely low roofline (ceiling height, 7 ft 4 in.), was lost among its neighbors, and additional height was badly needed to restore the balance. Expansion would have to be vertical, not horizontal as anticipated.

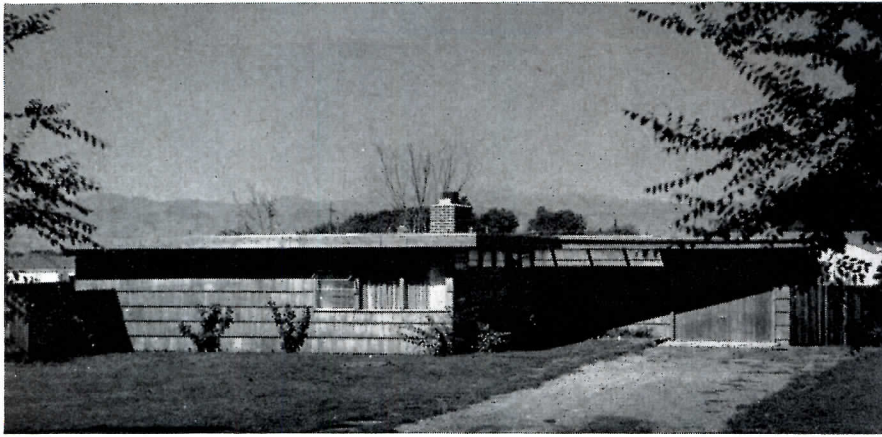

Original house was dwarfed by new neighbors; addition of second floor restored balance. Exterior walls are cedar pre-dipped shakes and vertical T & G siding



SECOND FLOOR

Lot is 300 ft deep, only 82½ ft wide, with mountain view to southwest. Angled placement of house permits terrace facing view and greatly increases privacy of outdoor living areas. Although horizontal rather than vertical expansion was intended when house was planned, ground-floor changes were minor. To make room for stairs, entrance hall was enlarged by moving door from inner edge of flagstones to present position, and space between heater room and garage (originally a storage alcove in garage) became stair well

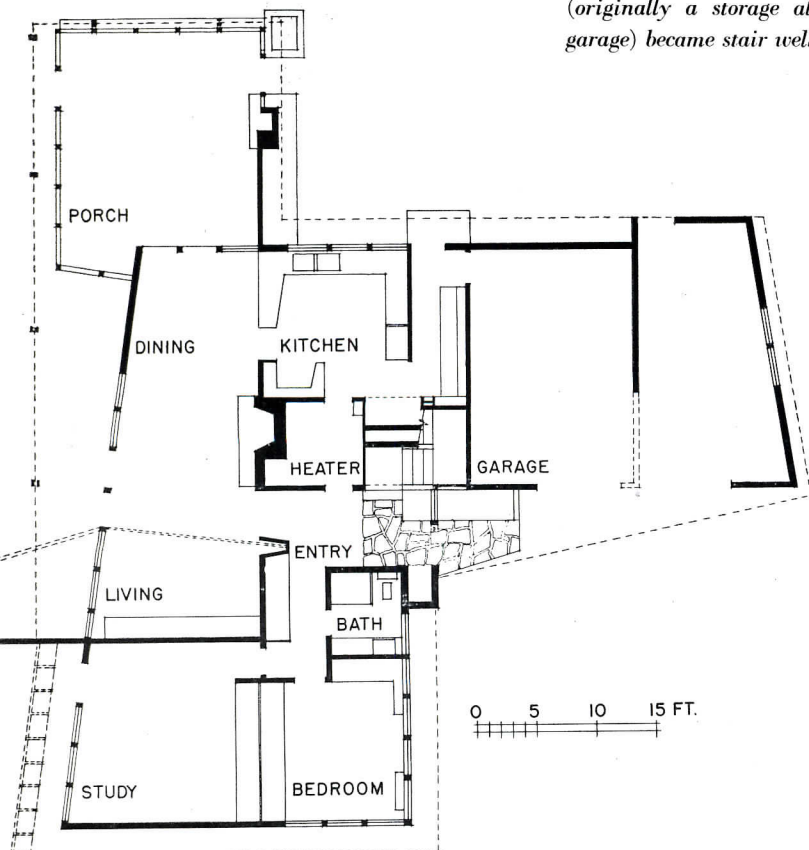

GROUND FLOOR

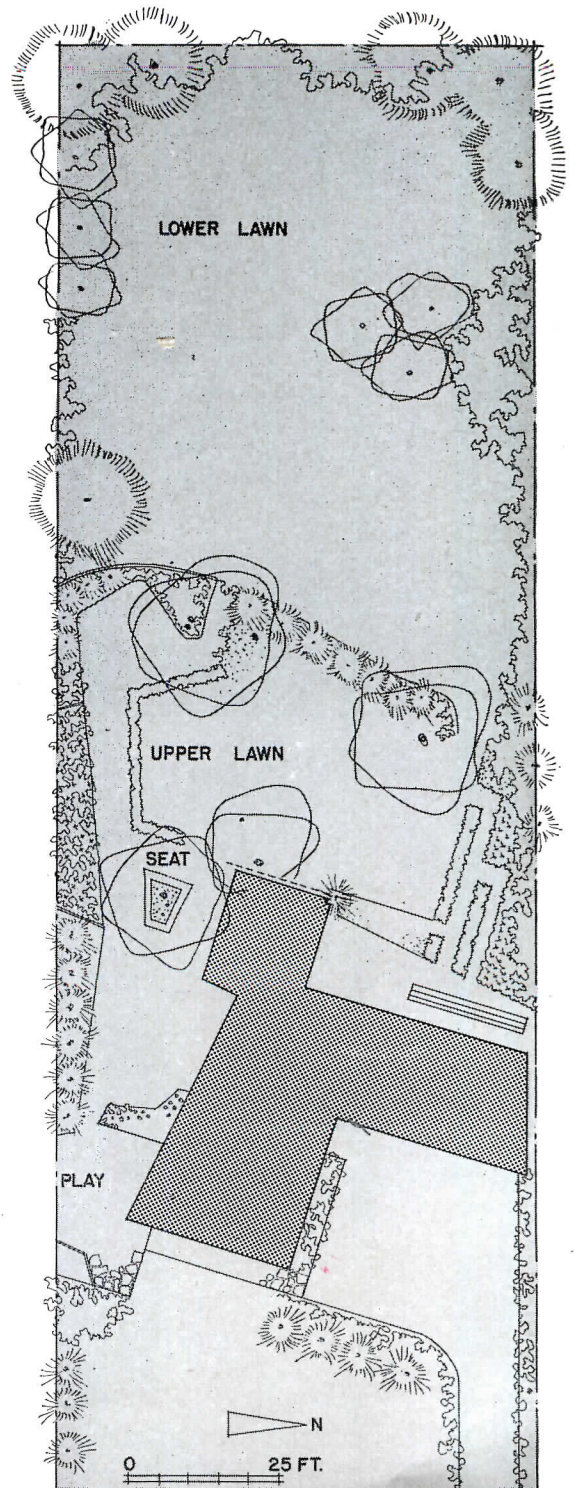

VERTICAL EXPANSION PROVES ADVANTAGEOUS

As things turned out, a second story proved to be not only possible but actually advantageous. The original plumbing stack, hot water boiler and chimney could serve the new second floor; the existing roof became the sub-floor of the addition; and all new bearing walls were related to existing exterior walls. Whereas the cost of the original house had been \$15 per sq ft, the cost of the 900-sq-ft addition was about \$7 per sq ft.



Photos this page, Marshall Brooks

When second floor was added dining room terrace was converted into a screened porch. Roof overhang along living room (below) previously had been extended to its present width with trellises and columns (top left, opposite page)



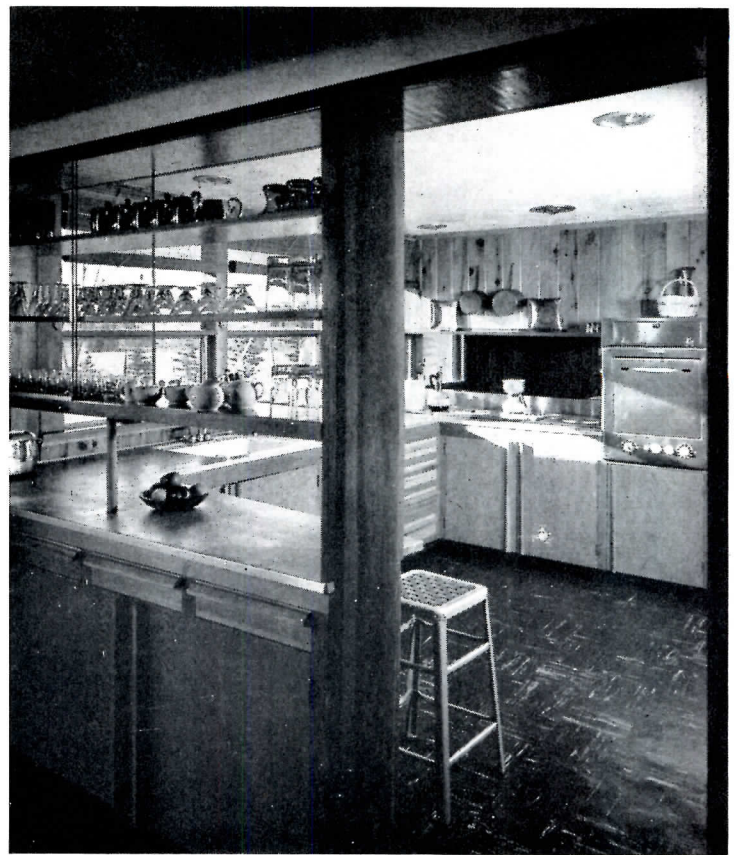

Barbecue fireplace is now within area of screened porch; it is only a few steps from kitchen. All interior walls on first floor are knotty cedar vertical T & G, cabinet work is fir plywood, floors are concrete with asphalt tile finish, ceilings are plaster tinted an off-white to blend with natural finish of wood. On second floor, all finish is mahogany, floors are hardwood (carpeted), and ceilings are painted gypsum board



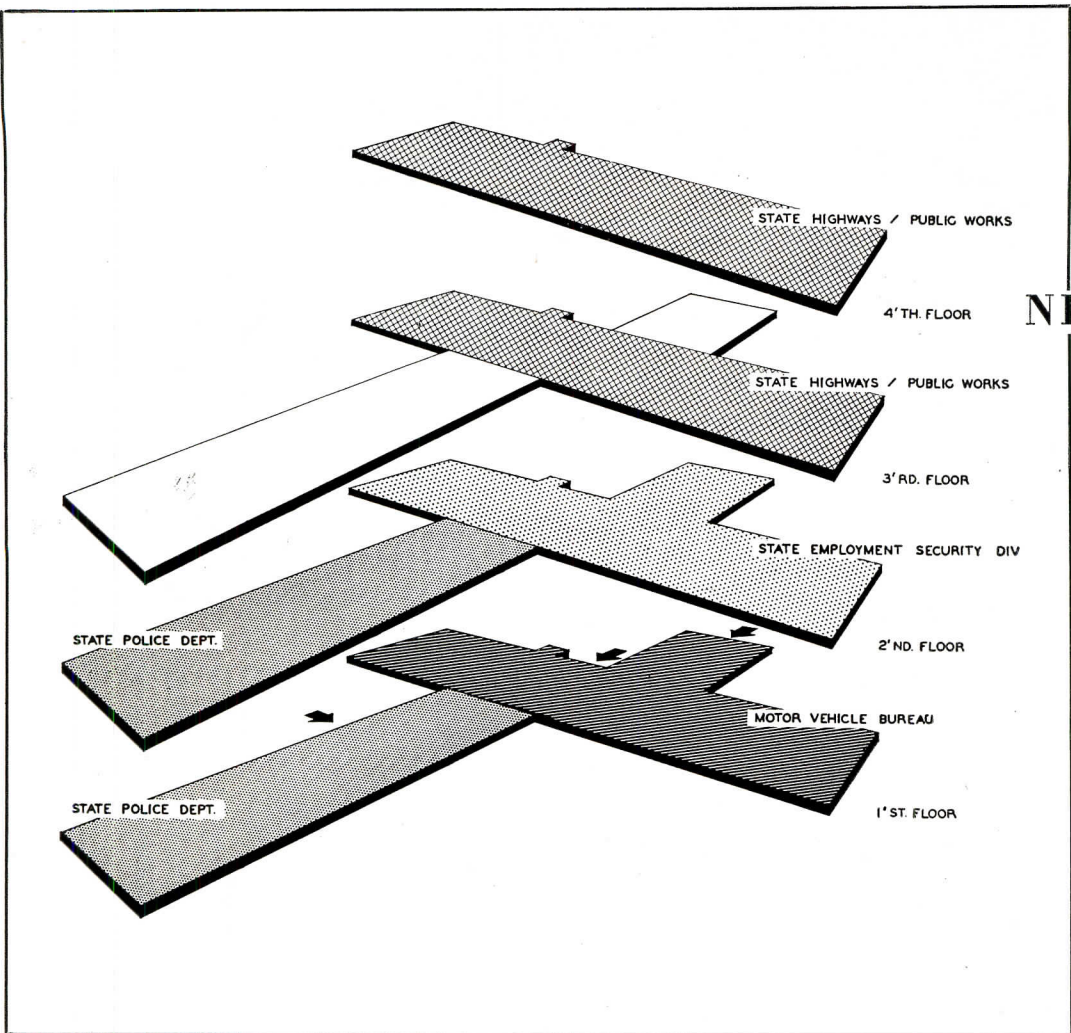

NEW HAMPSHIRE

Mogens Leth

Interrelation of plan elements shown by diagram: Police Department, open all night, is housed in a separate wing

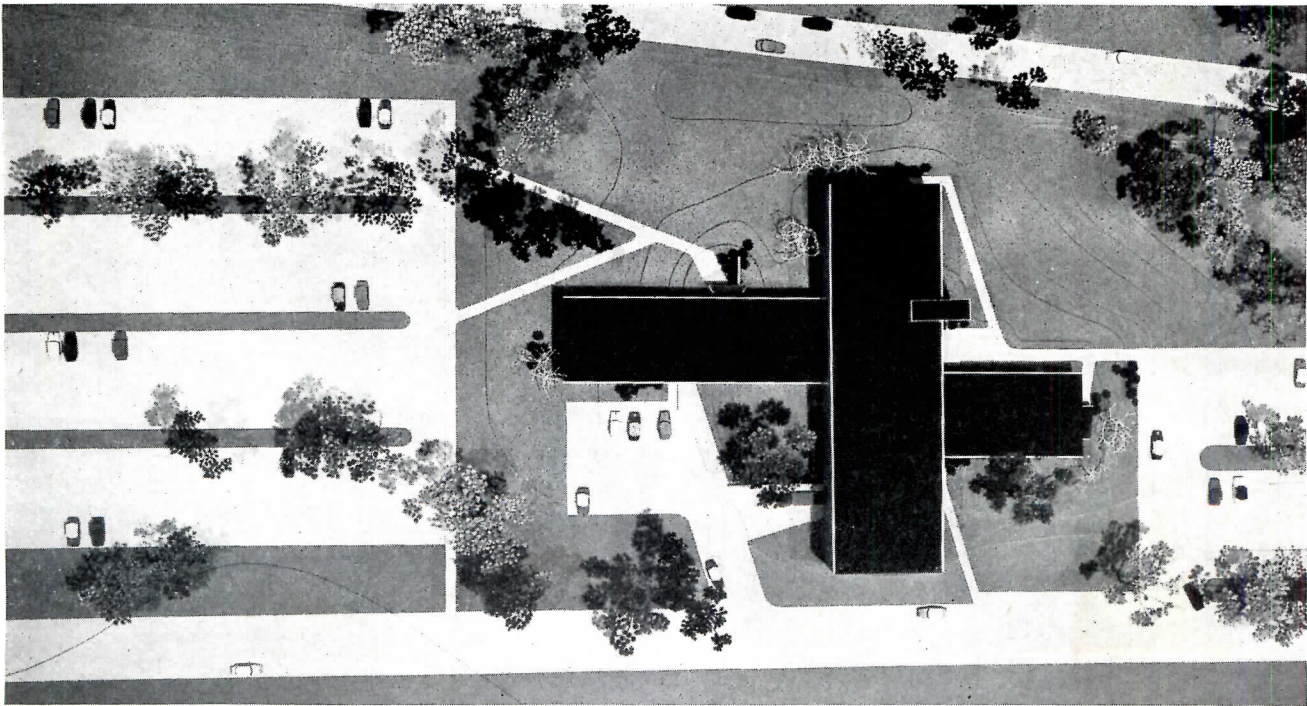

STATE OFFICE BUILDING SOON TO BE CONSTRUCTED

Nichols & Butterfield, Architects

James F. Russell & Bruce Graham, Associates

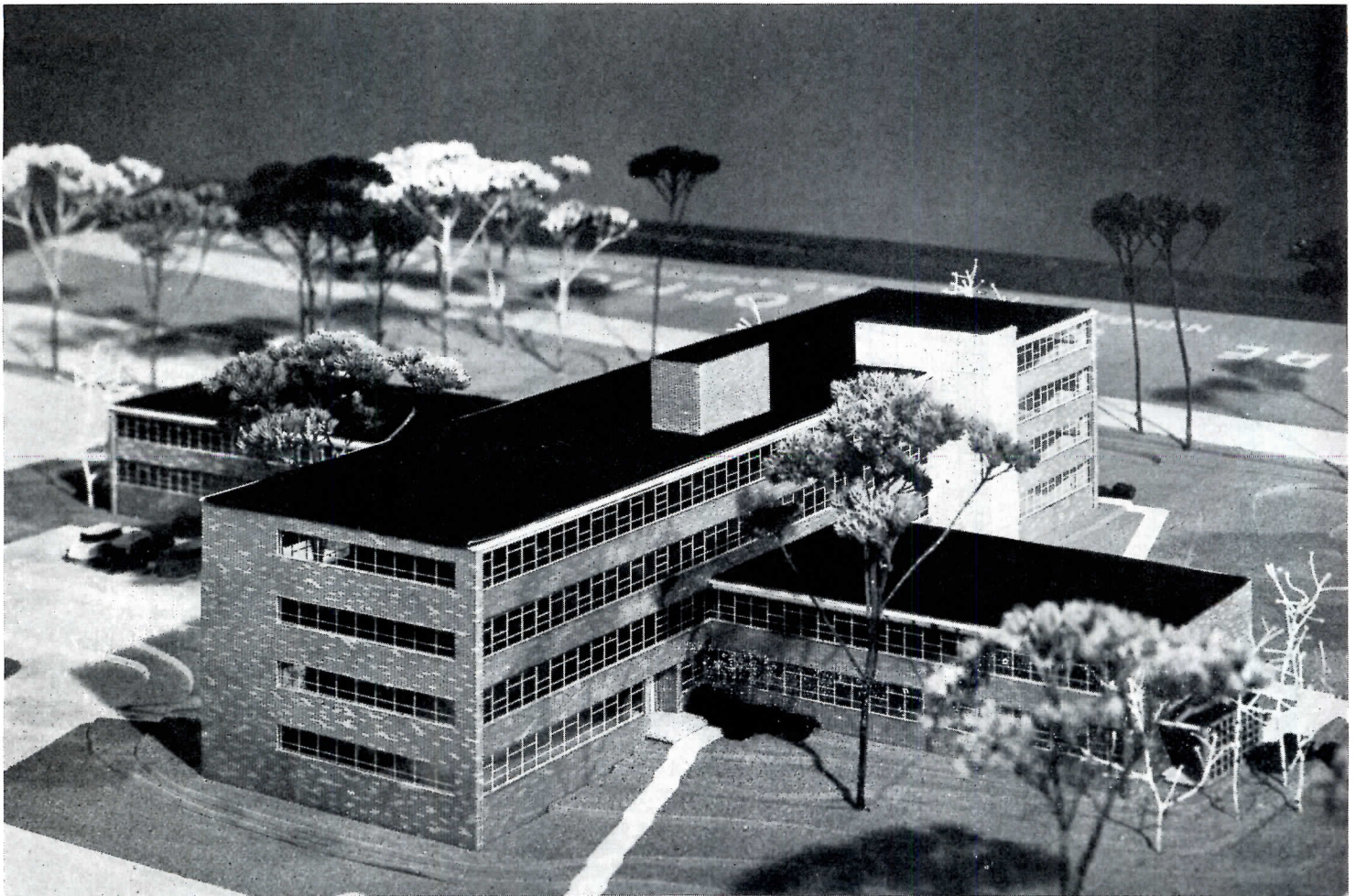

Joseph W. Molitor

NEW HAMPSHIRE'S newest office building will be built on a main highway near Concord and will be visible to motorists traveling north to the White Mountains ski and vacation areas. The building will house the State Police Department, Motor Vehicle Bureau, Employment Security Division, and Public Works and State Highway Departments. The design was placed first in a 1950 competition open to architects registered in New

Hampshire and was chosen from 29 entries. The competition was decided upon in order that as many ideas as possible could be reviewed and also to procure the best possible design skill. The original appropriation, inadequate to carry out the scheme, is expected to be supplemented by the necessary additional funds this fall so construction can proceed at that time. According to estimates, the cost should run close to \$15 per sq ft.

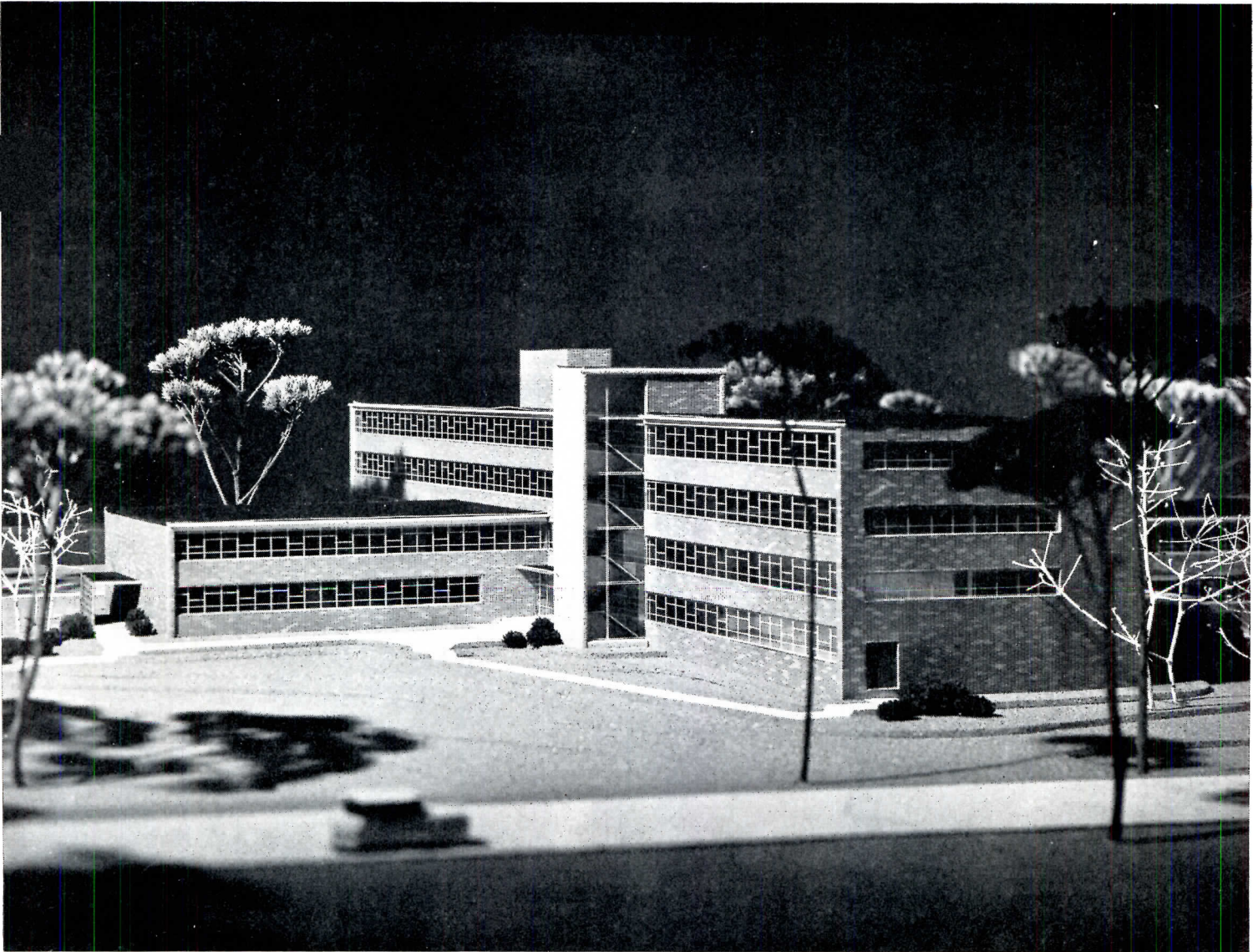
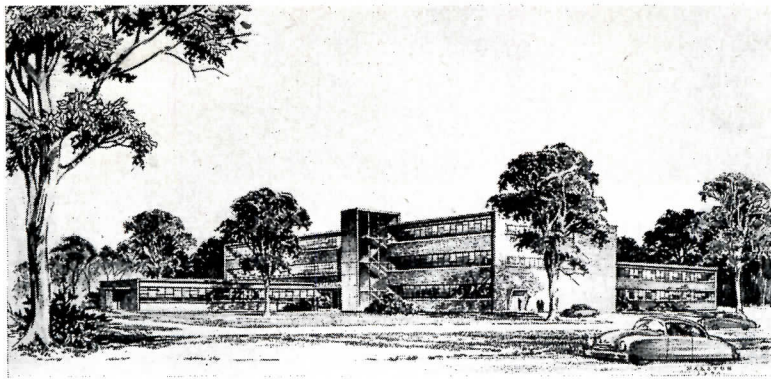

Rendering at top of page shows the design that won the competition in 1950. In later development, the architects were requested to add the Employment Security Division to the scheme, thus boosting the height of the central wing from three to four floors. The glass enclosed stair tower will be faced on one side with native gray granite; will be an exterior feature. The stair itself, of poured concrete, will receive its principal support from a central beam, thus making possible a 3-in. exposed edge next to the glass.

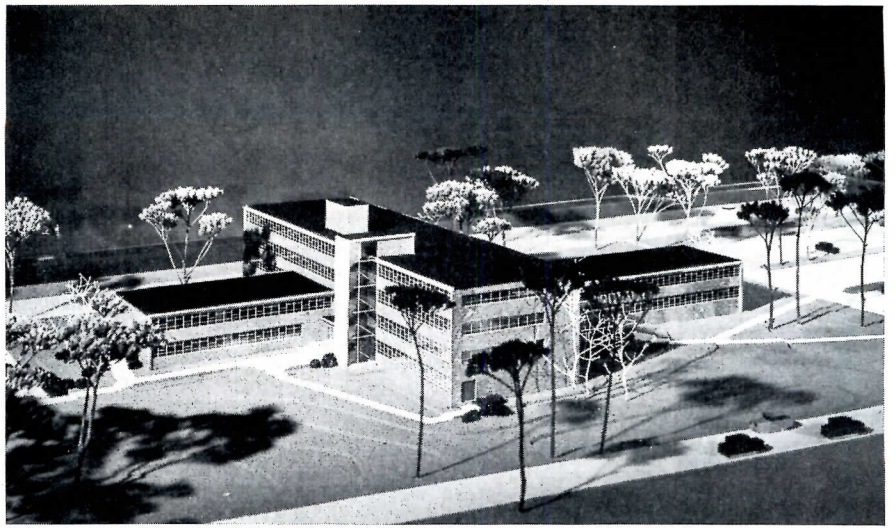

The building's orientation is such that its large central mass will be visible to northbound travelers on the adjacent highway

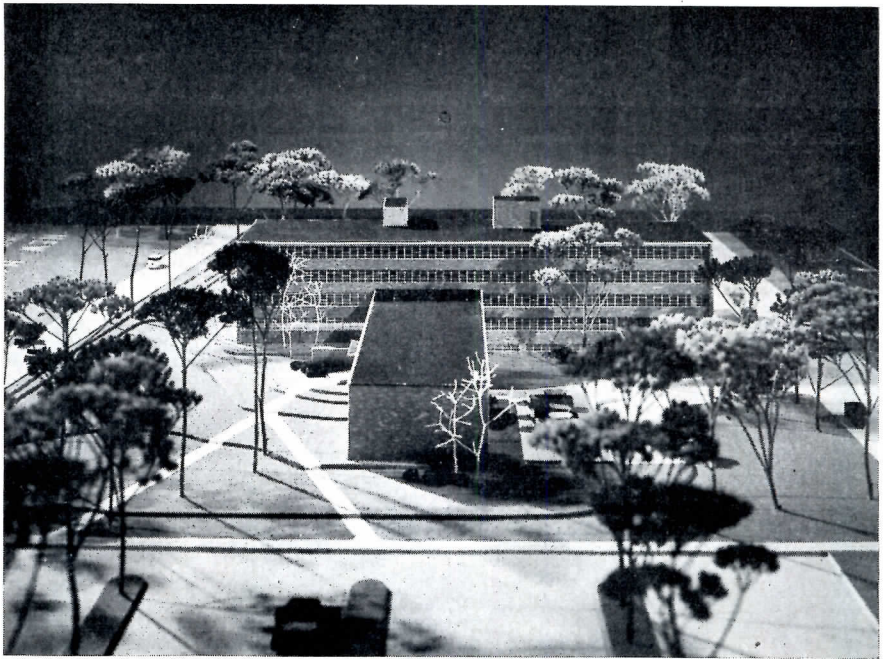

A 3 ft 6 in. window module and 21 ft column spacing combined with a structural flat slab system will yield maximum use flexibility

Joseph W. Molitor

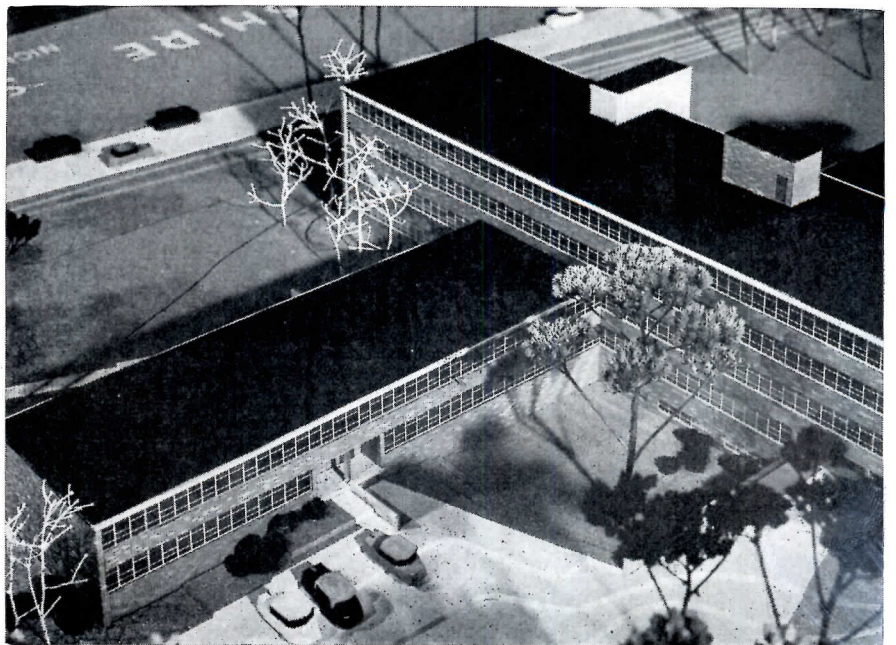
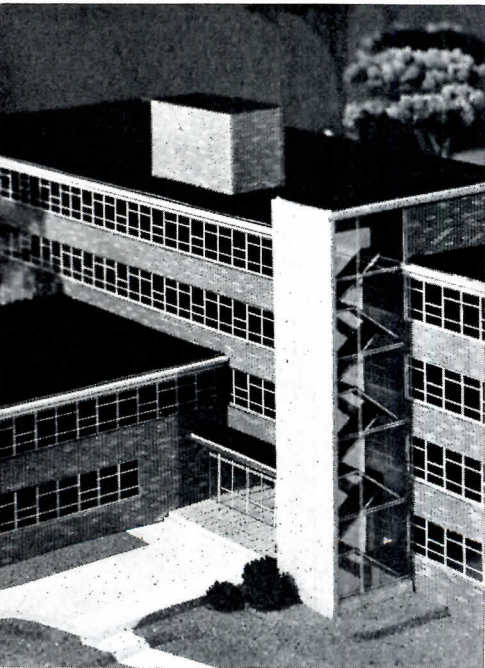

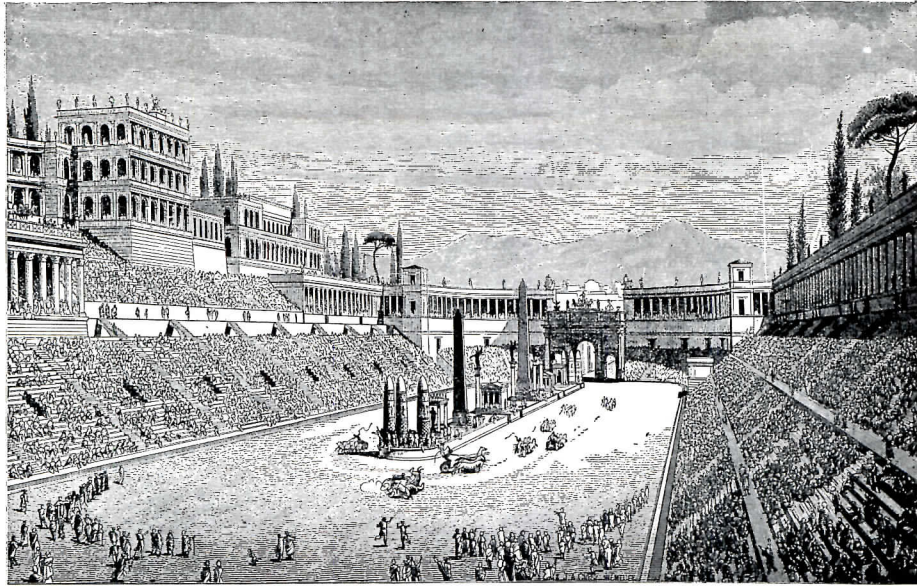

Bettman Archive

SOCIAL AND RECREATIONAL BUILDINGS

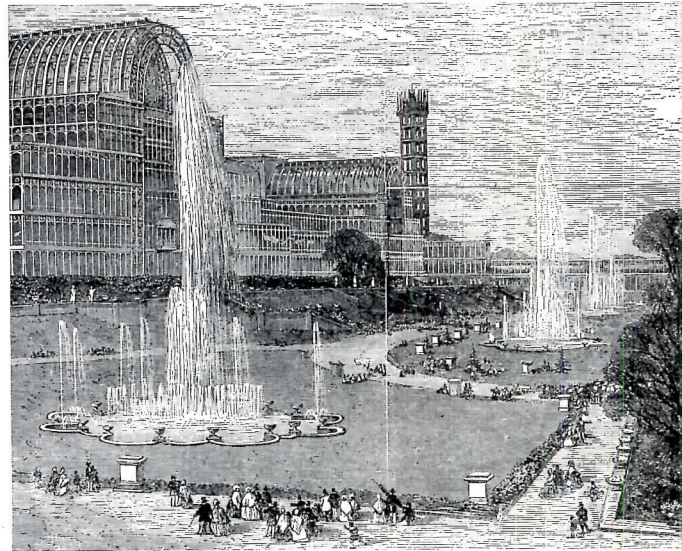

Bettman Archive



Chester—Black Star

Top: Circus Maximus, Rome. Above: The Fountains at the Crystal Palace, London. Left: N. Y. World's Fair — fireworks over fountains in Lagoon of Nations. French Pavilion in background. Top right: Saint Louis Browns at bat. Right: Play Sculpture by Egon Moller — Nielsen of Sweden

Illustrations on these pages remind us that from the earliest times man has always made much of festive and recreational gatherings, has in fact built some of his greatest buildings for such purposes. The difference today is that he builds many more of them, and of seemingly infinite variety. Last year, with materials restrictions removed, he built a great many such buildings; this year, F. W. Dodge Corporation estimates, he will build 12 per cent more than last year. Significantly he builds now for participation, not merely for "spectator sports" — and for participation by all people, young or old, rich or poor, in cities, suburbs, everywhere. While recreational matters have been highly organized for fifty years, never has there been such a push for more facilities for more people. "Social and recreational buildings" now answer man's knot-tiest problems, from increasing leisure hours, to education, to juvenile delinquency, to old-age loneliness, even to insanity. If there is a fault, according to Burchard (below), it is that we tend to specialize too much, and perhaps that we don't include enough cultural pursuits along with our swimming and our baseball. There is a challenge that should have great appeal for architects — to design a wide variety of buildings, to please all manner of people, to ease the strains and facilitate the adjustments of life, to make the buildings functional and beautiful, and yes, not to forget a little pinch of culture.

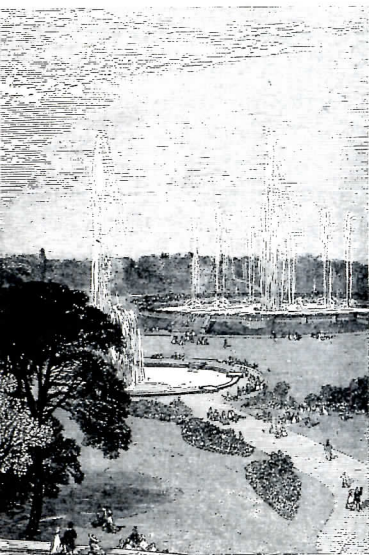

G. E. Kidder Smith



Try Imagination; Don't Forget Diversion

By John E. Burchard *Dean of Humanities and Social Studies, Massachusetts Institute of Technology*

AN AGE of specialization levies its tolls. Not the least of these is the insistence that specialism remain specialized. Thus the word "recreation" has come to have a limited meaning for most of us. Thus "recreational facilities" at once conjures up swimming pools and gymnasia and playgrounds and perhaps stadia and in-

door sports palaces. We will only by some unnatural stretch of our imagination be led to include theaters and opera houses and concert halls and cinema palaces. And museum directors have so operated, on the whole, that we will not think of museums at all.

Yet it is not far-fetched to include all these things

within the comprehensive term. Perhaps we should include more. If the television screen in my home is recreational, what shall we say of the studio whence come the signals that bring the set alive, even the studio where no claque is cheering the players on?

After all, "recreation" does mean "refreshment of the strength and spirits after toil; diversion; play." It is in forgetting the word "diversion" that specialism may lead us astray.

Some of us are unable to be angry at the Dodgers for treating Charlie Dressen so badly. Some of us are completely indifferent to the weekly prize fights or wrestling exhibitions (though fewer of us than many of us are willing to admit). Yet most of us can agree that there is undoubtedly diversion in such spectator sports. We believe it without having to have it proved by the admissions statistics. But this is not the case for the "higher arts." Even the lively arts are always seeking statisticians to tell them they are doing well. Librarians count their circulation figures. Museum directors put meters on their turnstiles. Sellers of pocket books try to point to evidence of a renaissance of culture by virtue of the thousands of copies of Shakespeare they sell, neglecting to remind us of the millions of Spillane. This makes them feel better about themselves.

We all want approval for our actions in support of other people's recreations. Most of us need this approval because our financial support is immediately affected by the slightest suspicion of waning public interest. And all of us in the long run need the same kind of support these days. Even the Metropolitan Museum or Opera have to meet payrolls and find enough ordinary people to support them in place of the few extraordinary ones who once did. The only reservation one can make about this is that the penalty for too small a box office perhaps falls more rapidly on Hollywood than it does on the Metropolitan. Also there may be more different kinds of kibitzers in Hollywood from the popcorn-selling theater owner through the mysterious degrees of magnatery that are reputed to govern the whims of the films. But perhaps really there are just as many kinds of kibitzers at the Metropolitan and they are only more secret and more correct.

In any event there is quite as much competition for a man's leisure time today as there is for his leisure dollar. There are many who want higher degrees of participation and object to spectator sports (I can assure the younger generation that there is a time in life when the more spectatorish, the better the sport). These people are making it easier all the time for us to get out of doors. They are getting highways to take us to the outdoor places and are designing the boardwalks and the dressing rooms at the beaches and the overnight lodgings and bars at the ski-bowls in the most entrancing terms. It is a joy to spend time at these places even as a spectator with never a swimming trunk on your haunches and never a ski-harness on your feet. After hours of things which might have been good for you, you can find it easy and pleasant to eat too many hamburgers and drink too much beer, things which are not good for you.

It is a little less clear that things are made easy at the movies or the theater. It becomes always less clear as the tone of the enterprise ascends. The location of these installations has not changed with the times, they are hard to get to, often hard to get into. When you do get in, you are often still looked upon with suspicion by jaundiced attendants. You cannot smoke or sing or talk very loudly or do any number of things that would contribute to the totality of the recreation. I suppose I need not describe the appearance of the lunchroom in a library or museum or the nature of the lunch itself.

All of our recreational activities, except perhaps one or two of the outdoor ones like skiing, seem to have suffered too much concentration on making the main activity work well. (Maybe after-skiing comfort looks so good because you are too sleepy to care.) The main activity must of course work well. The Dodgers cannot play on a cricket field. But a little more attention could be paid to the side facilities. Even if you like the paintings of Cadmus and Marsh, going to Ebbetts Field would be more pleasurable if it could be done without having some stranger pour beer down your neck. Going to the museum would be more fun if you did not have to look at so many pictures and could find the ones you wanted to see; and much better still if they did not have to be approached with so much awe. Sometimes a drink or two will do no harm to a painting, even one by Giotto. I seem to remember that a little uplift was tried once at Yankee Stadium but do not recall whether it was a howling success. Obviously, it will not be a success unless the Yankees are a pennant contender and perhaps it is not needed if they are. But I suspect it would help.

I am not certain how much help the great light and popular recreations need in the way of diversified surroundings, but I am certain that the great serious and unpopular ones do need this help. And I am not suggesting that we build a football playing annex onto the back of the new Guggenheim Museum.

But life is a rounded thing and is not parceled out quite as our recreational buildings assume it to be. We spend a great deal of time in the educational world talking about integration of disciplines. We talk more than we accomplish, but anyway we talk. It seems to me it might be valuable to do more talking about the same thing in recreation. Great paintings could do no harm at Jones Beach and I mean great painting, not something dreamed up for the assumed taste of a beachcomber. The guy in the swim suit accumulating a burn may be already interested in painting, but if he isn't this is the place to catch him and not in the Metropolitan. By the same token it ought to be possible to have more fun in a museum, even to the extent of having a pleasurable lunch and some sense of intimacy with paintings which were never intended to be laid out in rows competing with each other all over the place.

I do not know what buildings will be shown in this issue, but I am willing to wager that you will find many of them handsome, convenient, admirably calculated to take care of the direct need which brought the public to them; and that by the same token you will find none

of this integration with other recreation for which I seriously plead. We have to believe, most of us, that there are things which are first class and things which are not, and we worry that so many people never seem to care for the first-class things we care about. But our efforts to give them a chance to care are puerile. And there is no other opportunity so grand as that of catching them off guard and in a festive mood.

I remember once hearing Alvar Aalto criticize a set of student designs for a progressive school. These designs were very knowing. All the students had met a progressive school teacher. All knew the heights of the little desks and other little things that little ones need in a progressive school. Each had incorporated radiant heating and north light and color and whatever else you have to incorporate. But all of them looked alike. Aalto had a simple but devastating question. "Tell me," he said, "where does the bear come in the window?"

We need more bears coming in the windows of recreational buildings. All it takes is a little more gumption, a little more imagination, a little courage to do something crazy. Very few important works have been accomplished by the thoroughly sane or are the product solely of inexorable logic. Orderly recreation, concentrated recreation, specialized recreation are almost a contradiction in terms. Let us have more bears and fewer directional signs.

I know that many museum directors and perhaps some baseball front offices are worrying about these things, but the fruits of their worries are very slow in coming ripe. On the whole only marginal successes can be expected in these directions. The great new opportunity probably rests in the community center which does have recreational purposes and does have to cater to a variety of recreational interests. This is a very real opportunity. If each specialized activity is made very good but is not thought of in connection with others, even the apparently extraneous, each citizen can go his hermetic way to his single hermetic amusement. He can bang ping-pong balls all night and never know that he might have enjoyed painting or square dancing. The utmost imagination may indeed result in buildings in which it is not too all-fired easy to reach the place where you can do the thing you want to do but have to encounter something else on the way. This will not be accomplished by making the whole business so infernally flexible that you can do anything everywhere even if you can do nothing very well anywhere. Rather, the recreational complex will consist of very specially functioned spaces put together like a great encyclopedia which educates us not by what it tells us about the subject we were looking up but by the other unexpected things we find on the way to the truth we were seeking. This is what I think Aalto meant by his bear.

Right: *The Wedding Dance* by Peter Bruegel.
Below: *Ball of the Nobility in residence of German petty state, ca. 1750*. Below right: *Dancing the "Jarake Mixteca," Mexico*



Detroit Institute of Arts



Bettman Archive



Waller Reuter from Black Star

Park-School Cooperation Adds to Funds

Relatively new in planning for recreation is the collaboration of the city park system and the schools. Planning and spending together they both achieve much more. And the activities of different age groups fortunately divide the hours of the day to permit multiple use of the facilities without too much overlapping or confusion. Legal regulations have frequently been restrictive, but these are being surmounted in increasing numbers of cities, including some of the largest. Seattle is a notable example, as witness the large field house shown below, but there are many others. Such collaboration involves, of course, especial cooperation in site selection, but once this is accomplished combined budgets come into play, and more facilities can be built and more intensively used. The idea seems to work best when the school is a high school, since here the facilities tend to get the most expensive, and, of course, prove most useful to larger groups of citizens. And the high school then can become the true community school, offering its shops and meeting rooms, even its cafeteria, for adult use.

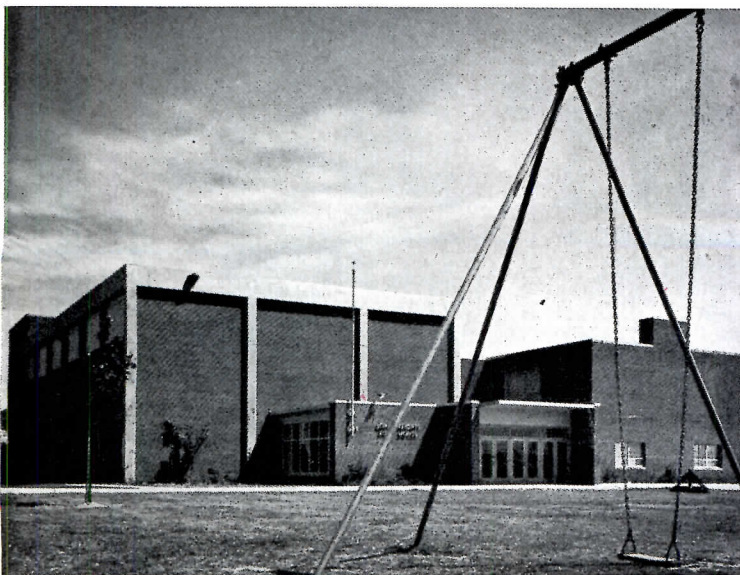
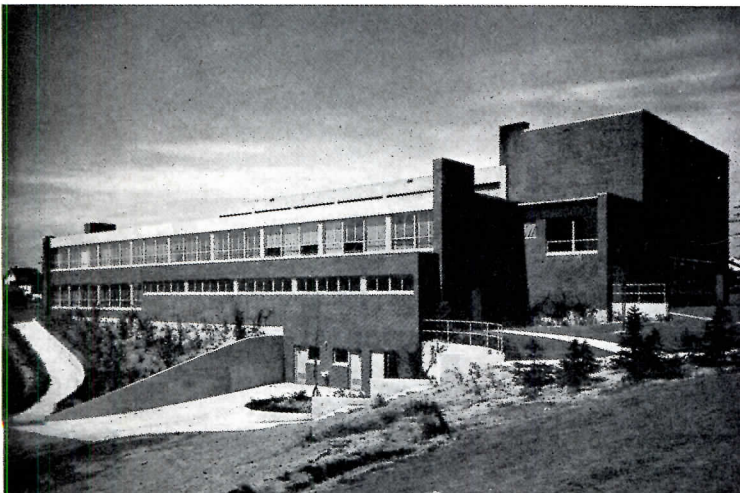

LOYAL HEIGHTS FIELDHOUSE SEATTLE, WASH.

*Naramore, Bain, Brady & Johanson,
Architects*

*Lincoln Bouillon & Associates,
Mechanical-Electrical Engineers*

*W. H. Witt Company,
Structural Engineers*

1 Since the war Seattle has been rapidly expanding its park recreational program, frequently joining with the School Board. This field house provides indoor facilities to go with an athletic field comprising four city blocks. It has a combination gymnasium-auditorium (650 seats) with full stage and dressing rooms, social and lounge rooms with kitchen for catering service, game rooms, and, of course, the toilet and locker facilities for outdoor sports. Note especially ceiling in gymnasium; inverted Pratt trusses added seven feet of available wall height for a band of directional glass block, throwing daylight against down-sloping ceiling. Furred ceiling contains air diffusers and guarded light fixtures, accessible for servicing through catwalks above the ceiling. The building contains 26,000 sq ft gross floor area, and was designed for a construction budget of \$325,000.

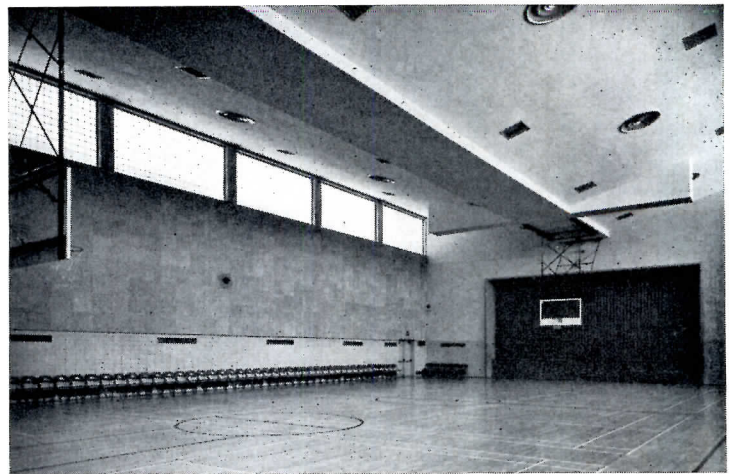
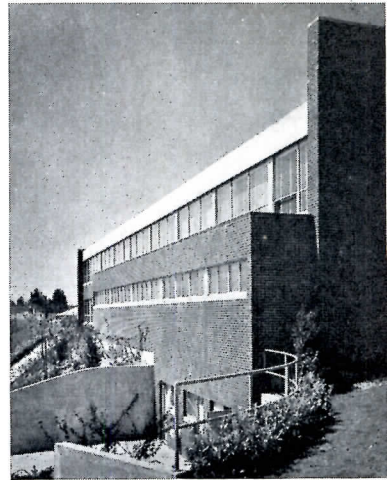
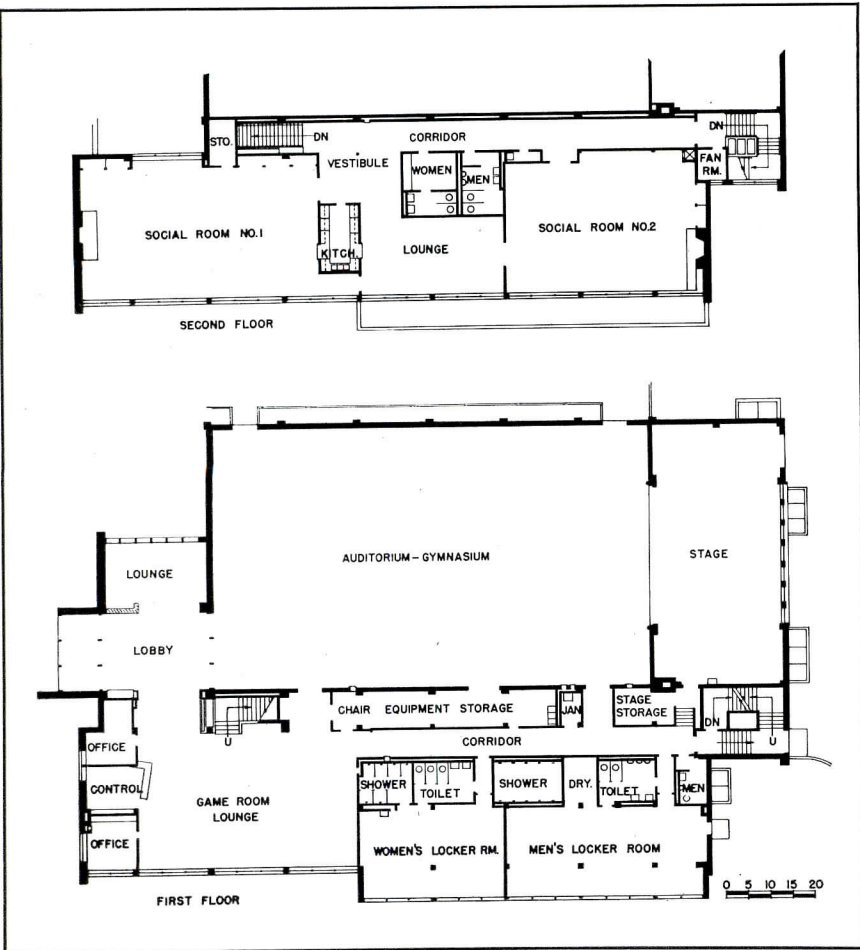

In addition to the facilities in the first floor (plan above) the building has, in basement, field toilet and locker rooms, storage and equipment rooms and, in second floor, two social rooms and lounge with kitchen facilities for serving buffet-type meals

Recreation Centers Keep the Kids Occupied

Recreation centers, or youth centers, are a very active type. More sharply defined, the youth center addresses itself to the needs and problems of young people, and may, especially in the large city, focus its design quite sharply to youth even though it offers variety of entertainment. For example, a youth center must be designed for close supervision of all areas. Buildings of either designation, however, offer similar activities — arts and crafts, dancing, music, some indoor sports, social facilities generally. Many are built by cities, many by other groups, frequently as war memorials. There have been some for handicapped people, with facilities for the blind. Such buildings are springing up in small towns as well as in large cities.

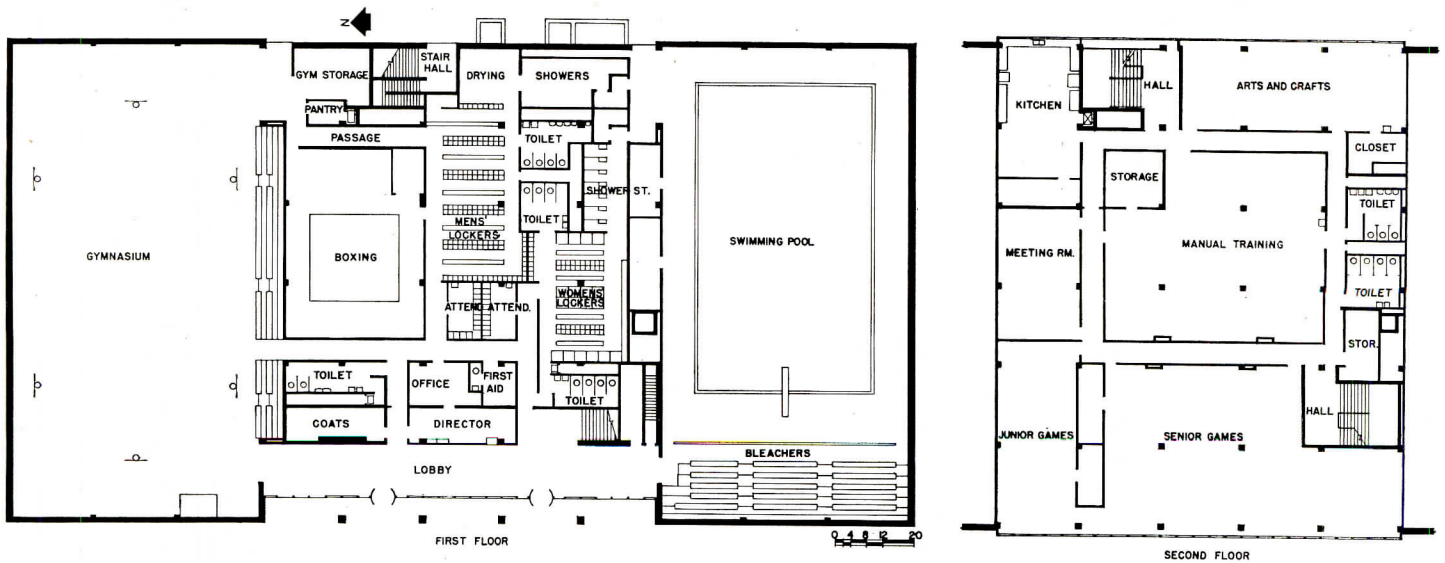

2

**THOMAS JEFFERSON
RECREATION CENTER,
NEW YORK CITY**

Edward D. Stone, Architect

A representative recreation center for a large city, this is one of several in New York City's program. Note especially the facilities shown on the second floor plan for manual training and arts and crafts, also rooms for varied games. These are additions to earlier ideas of recreational centers, and broaden the usefulness of the building. Notice also, first floor, that locker and shower rooms are kept in the center of the building, and are designed for very close control. Youngsters in the tough neighborhoods profit immensely from these facilities, but are inclined to play rough if not controlled.

Pat Responte

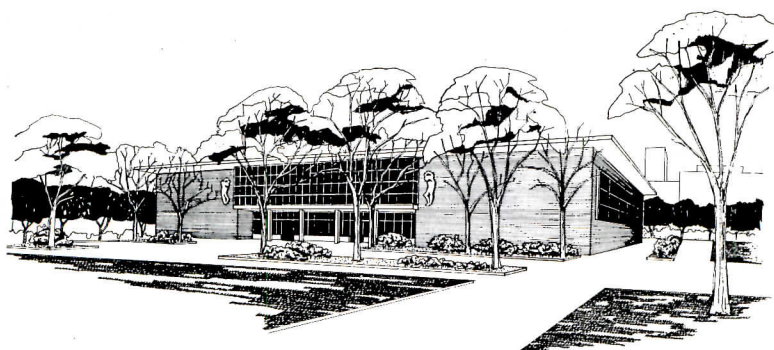

**RECREATION CENTER,
HIGHLAND PARK, ILL.**

Bertram A. Weber, Architect

Though small compared with the large city centers, this one is for the community activities of adults as well as the sports of the youngsters, for a town of 18,000 population. The energies of the young are normally confined to the lower floor and the gymnasium, though the gym has balcony seats at the upper level. The community hall, with small kitchen attached, is designed to serve the varied purposes of adults, though the crafts room and the darkroom might also appeal to the grownups.

The site is wooded park property on the slope of a hill, adjoining open field and play areas. These are on a lower level at the rear, so there is a natural separation of activities. Play areas are paved with blacktop to be useful in any but the worst weather. The building is of red brick with limestone trim. Interior walls are exposed masonry for durability and economy, as the building was limited by the bond issue to \$200,000.

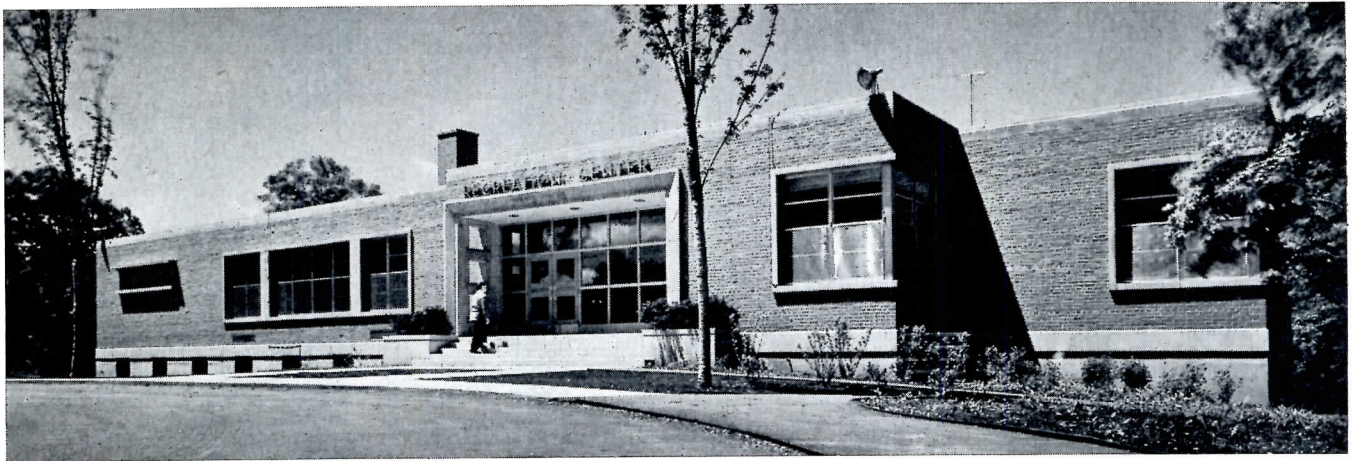
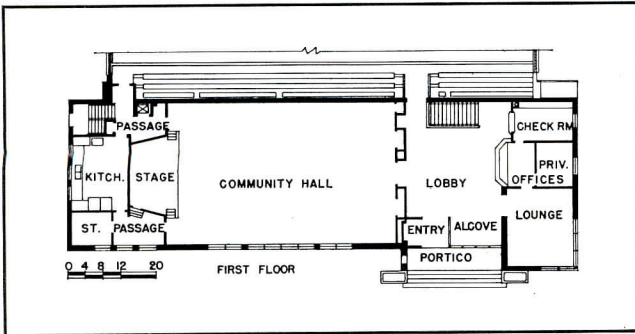

Hedrich-Blessing

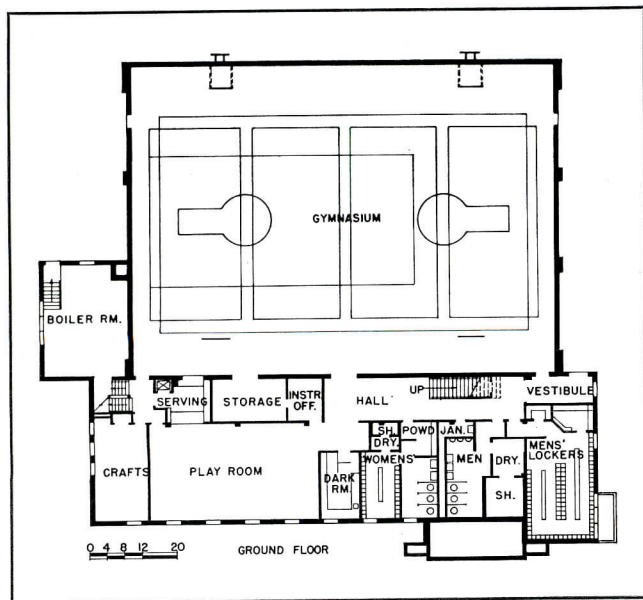

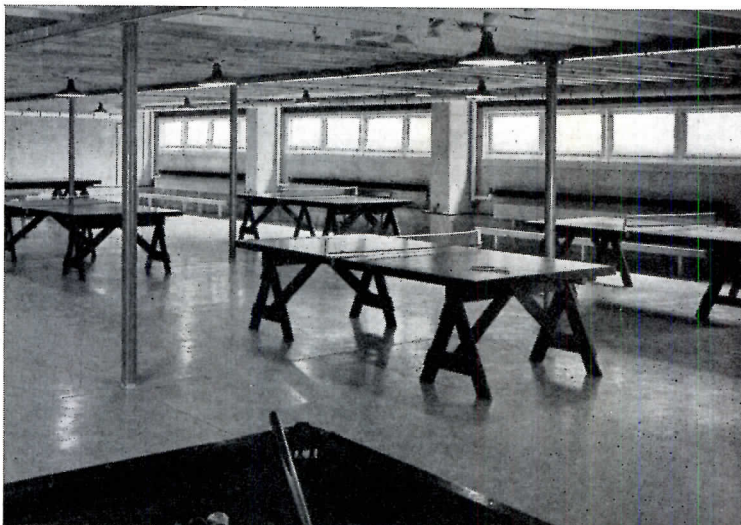
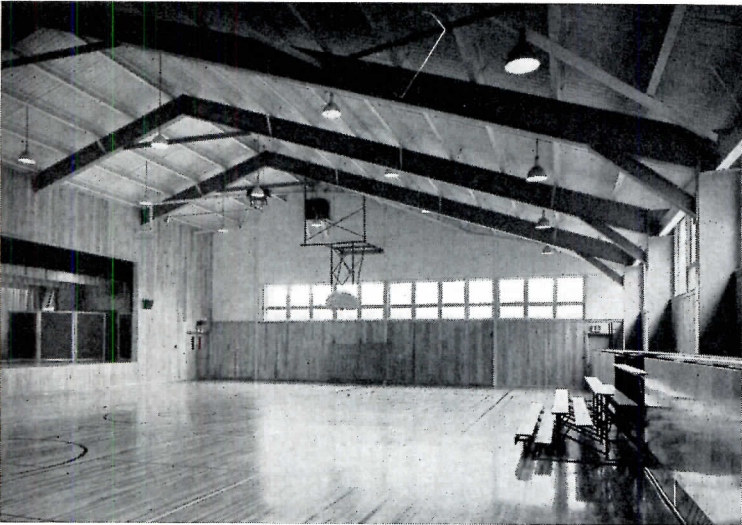
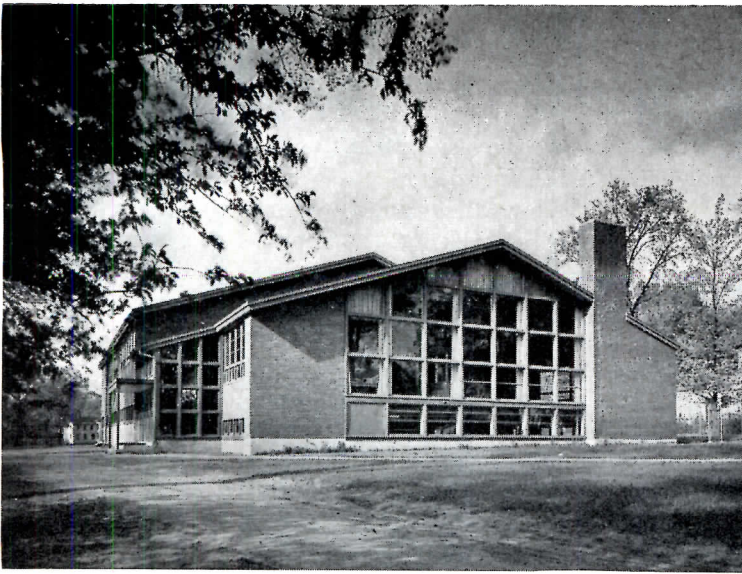

Joseph W. Molitor

4

**GENTLE COMMUNITY BUILDING,
HOULTON, MAINE**

*Alonzo J. Harriman, Inc.,
Architects and Engineers*

This community building was designed to house facilities for all types of community and group activities, such as basketball games, concerts or lectures, club meetings, scout gatherings, dances, and so on. The gymnasium has a 70-ft stage at one side for use as auditorium or theater. The two main rooms on the lower level are for varied use. The building was done very economically, its cost being \$123,750 for an area of 10,000 sq ft, giving a unit cost of \$7.75.

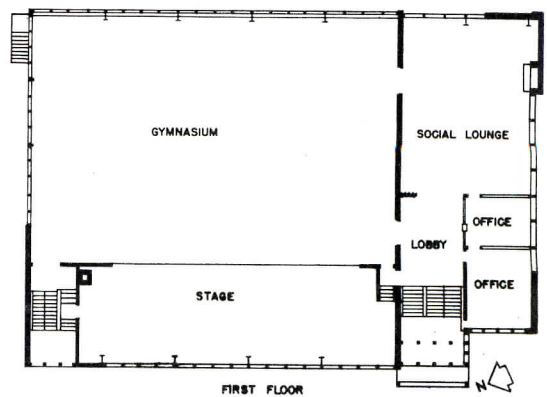
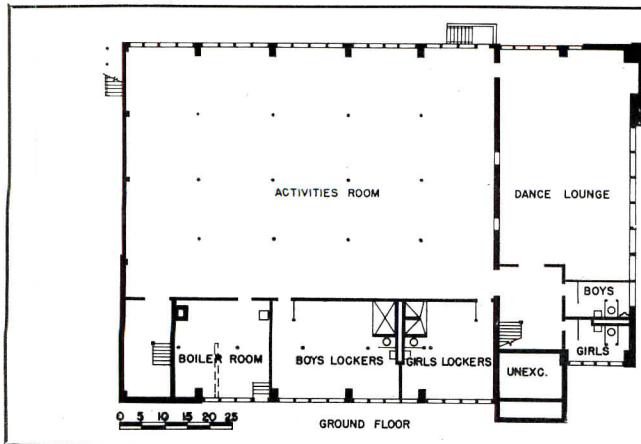

Playgrounds Have Discovered Design

Playgrounds, one of the earliest-seen recreational needs of the city, are still very active. Trends: generally less formality, more imagination (play sculptures), more real fun, more variety. Originally for the tots, they are now for everybody, including the old folks, so they have grown larger, always with good separation of active and passive sports. Note: a good place for a bit of art and culture.

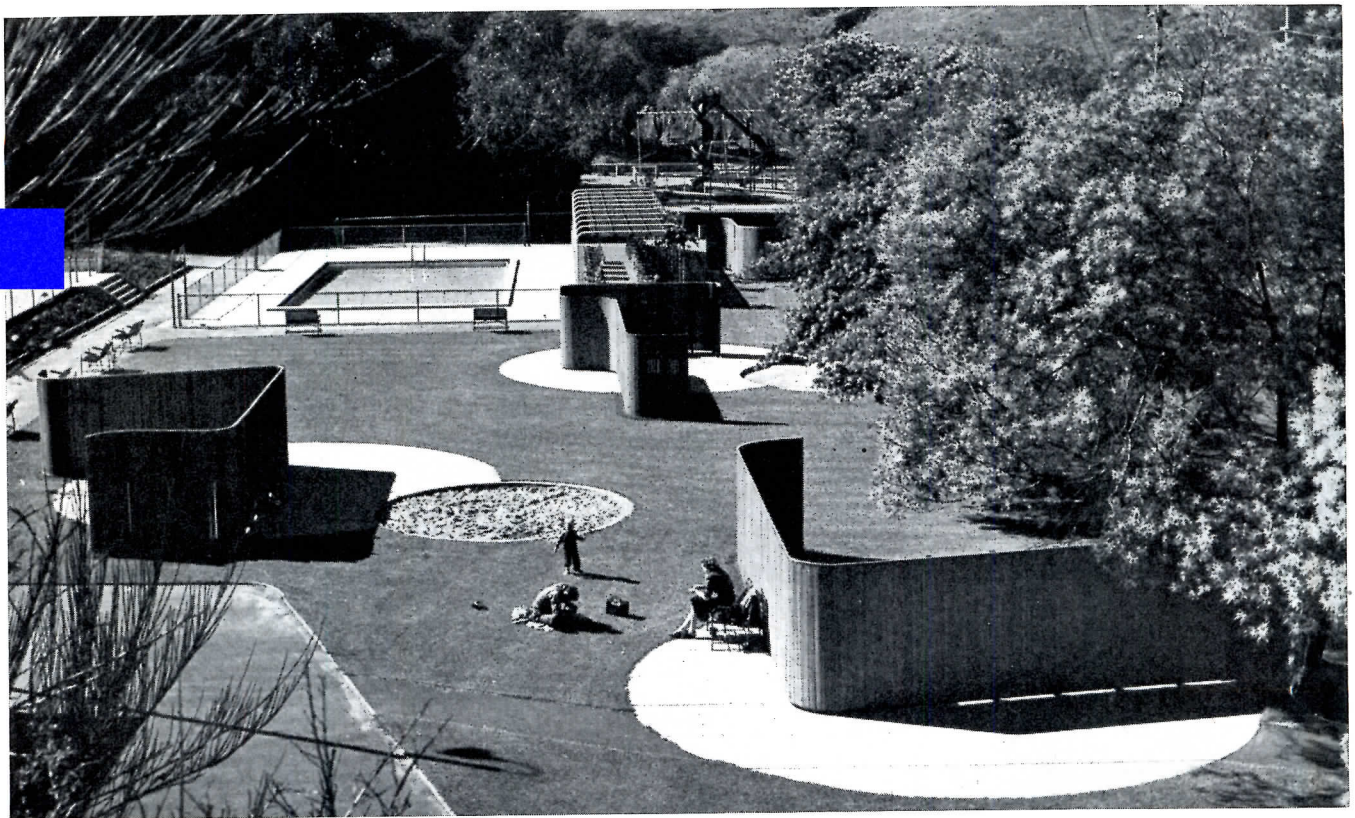

Ernest Braun

5

**STANDARD OIL CO. OF CALIF.
ROD AND GUN CLUB,
RICHMOND, CALIF.**

*Eckbo, Royston and Williams,
Landscape Architects*

A good dash of imagination has converted this recreation area for Standard Oil employes from just another playground into the handsome center shown on these pages. The various techniques of landscape planning, contrasting textures, colors, light and shade, forms and plants, have been put to the practical uses of organizing and segregating facilities for different activities. Redwood screens serve as windbreaks and sunshades, and give privacy for sunning, sitting and talking. They are placed on a variety of play surfaces: concrete, grass, sand and tanbark. All construction was done from the landscaping plans by the employes themselves with materials furnished by the company management.

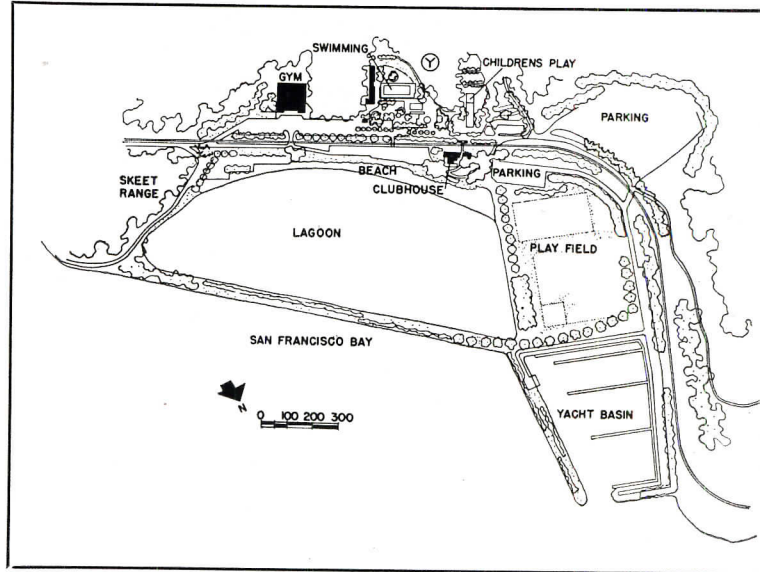

The Rod and Gun Club playground, illustrated here (top plan far right), is a part of the large recreation project shown in the plan above. Play equipment is brightly colored, segregated for age groups. Three pools are provided; the bathhouse and snack bar were designed by Ray Elmer and E. S. Meddaugh

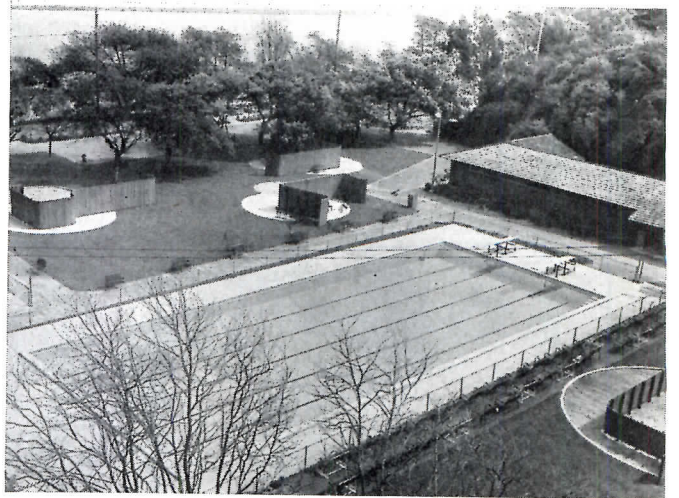
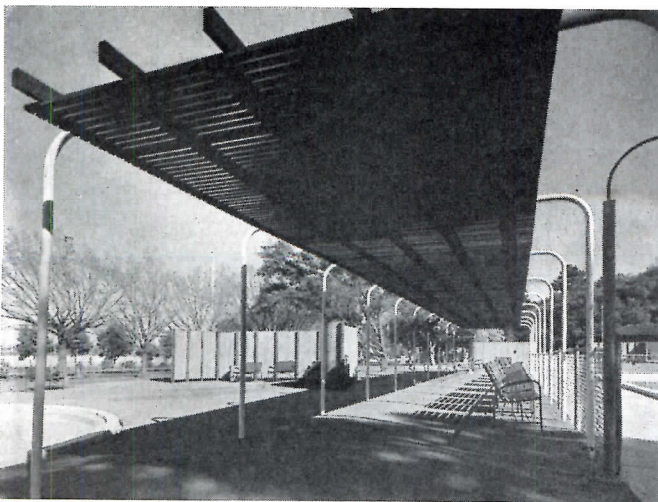
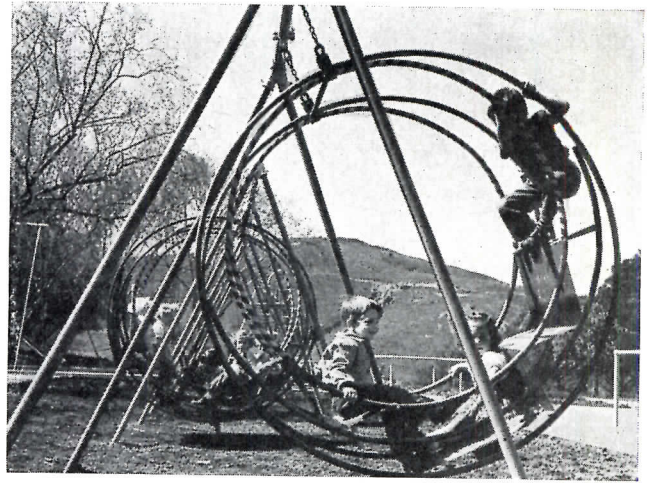

Ernest Braun

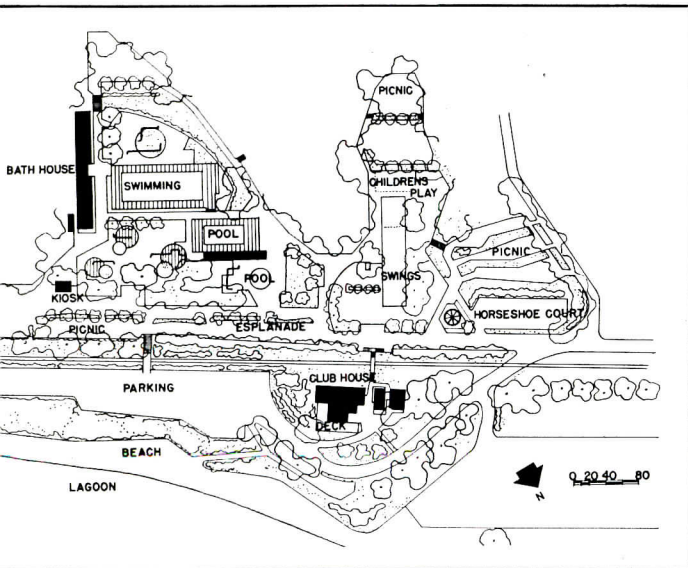

SOCIAL AND RECREATIONAL BUILDINGS

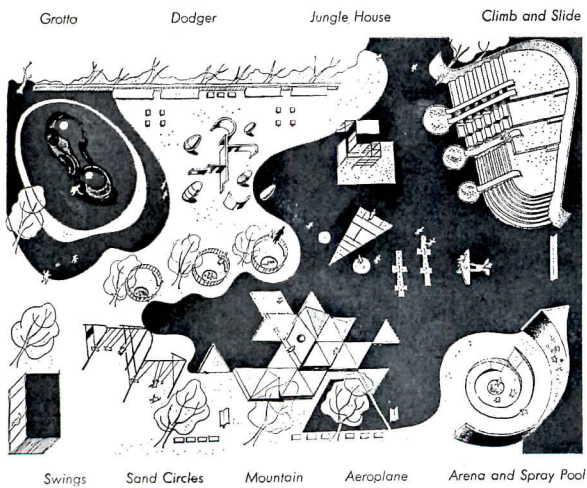
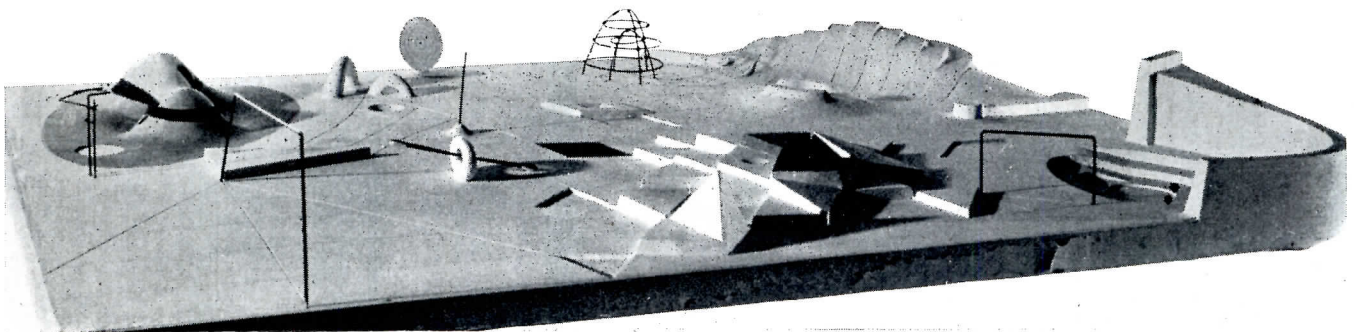

MODEL FOR A CHILDREN'S PLAYGROUND

6

*Isamu Noguchi and
Julian Whittlesey, Designers*

Sculptural play forms are among the newest trends in playground equipment, with some now commercially on the market. They include redesigns of traditional equipment, as well as some original items, and are intended to stimulate a child's sense of color, space and form. This project groups a number of such play forms into a landscaped playground for younger children.

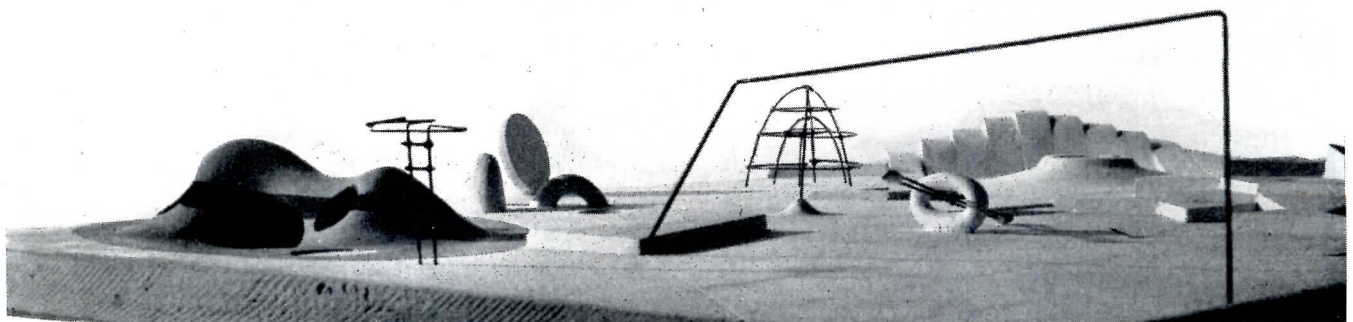

Libraries Develop Their Social Sense

Libraries are not a stranger in this Building Types Study, especially since "the library is no longer a mere symbol of culture or a civic monument . . . it is becoming a friendly place which reveals the resources within and invites one to share its hospitality" (page 149, Dec. '52 AR). And especially since libraries are adding new activities: music, films, recordings, art and art exhibitions, story hours and other special appeals to different age groups or classified interests or hobbies. Frequently the library becomes the community center. Some even have smoking rooms and lounges to put reading into the class of "social" or "recreational."

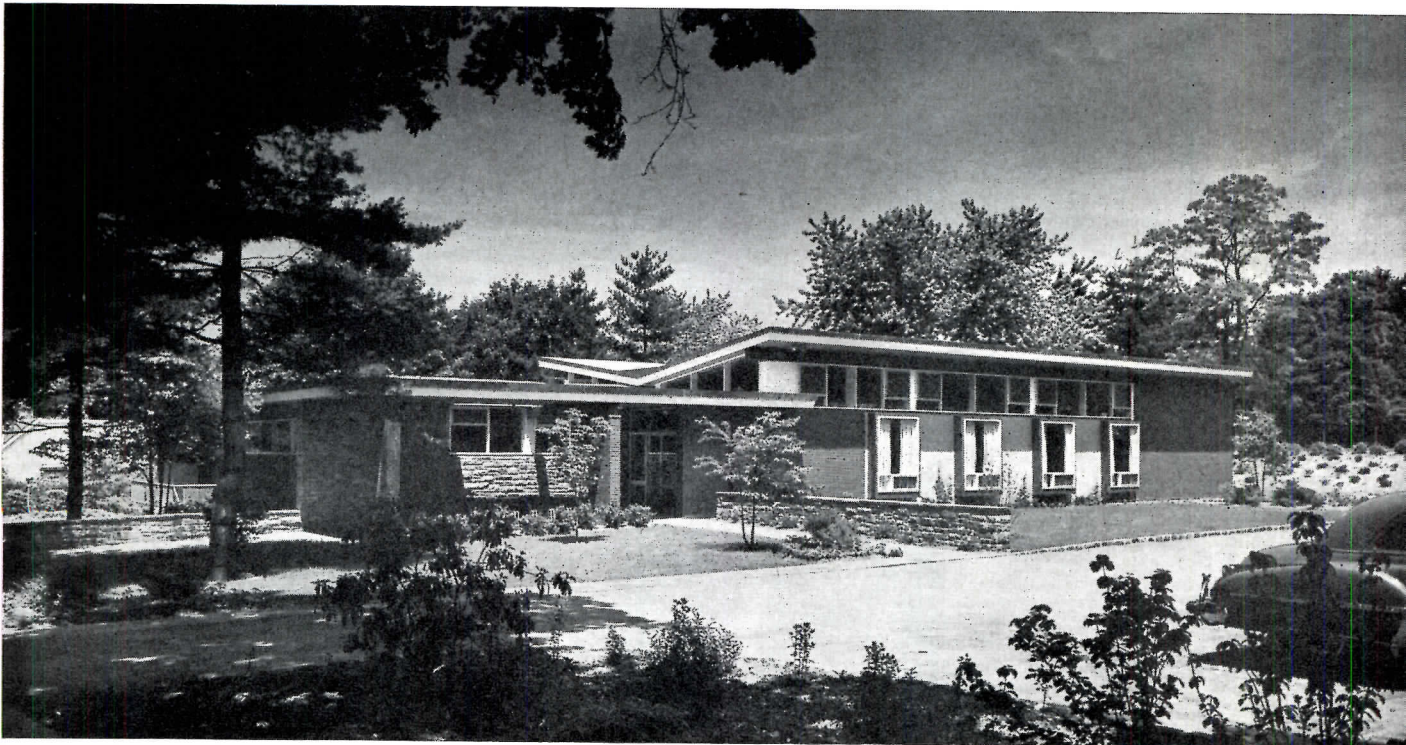

Ben Schnall

7

MANHASSET PUBLIC LIBRARY MANHASSET, NEW YORK

Gibbons & Heidtmann, Architects

A crisp, bright and friendly air sets this new library apart from many of its antecedents, and makes it a pleasant place to go for browsing, reading or study. The exterior has a strong domestic character, with red brick, white trim and landscaped grounds. Inside, the plan has been kept as open as possible, with low book-cases serving to divide most areas. Because of the noise problem, however, the children's section is closed off by a plate glass wall. Placement of the charging counter near the single entrance gives good but unobtrusive control of the entire area in the library.



Use of a butterfly roof permits high windows on all four sides of the building, yet avoids excess ceiling height in the room. The ceiling is surfaced with asbestos-cement acoustic tile. The two sections of the charging counter are divided by a sliding glass panel to give flexibility

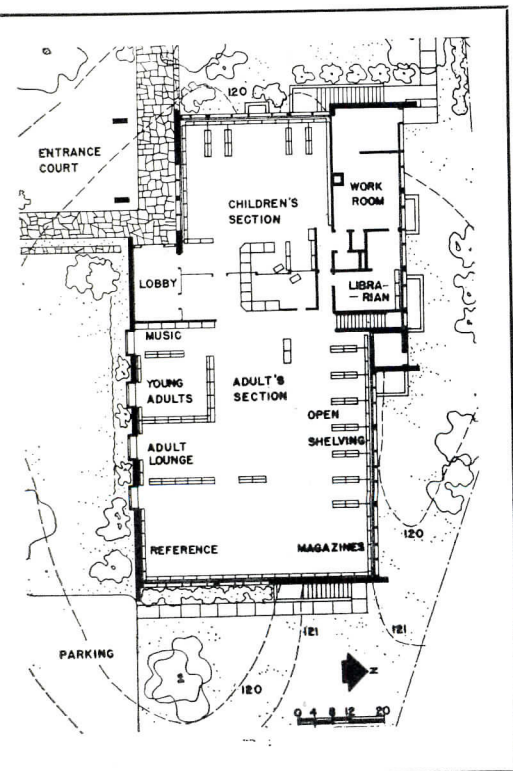



8

PARKSIDE BRANCH LIBRARY SAN FRANCISCO, CALIFORNIA

Appleton & Wolfard, Architects

"Library with a clubhouse look" is the label the local newspaper gives this new building. The title is perhaps an apt one for the current concept that a library should be planned for use, enjoyment and relaxation. Large areas are set aside in this example for a lounge-like browsing room and a reading terrace. Both can be shut off for use as meeting, display and social areas without disturbing patrons in the reading room.

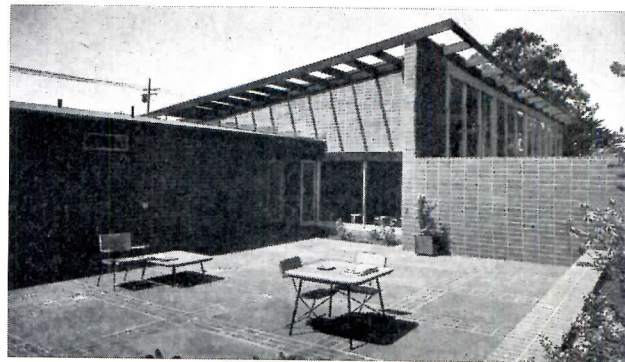
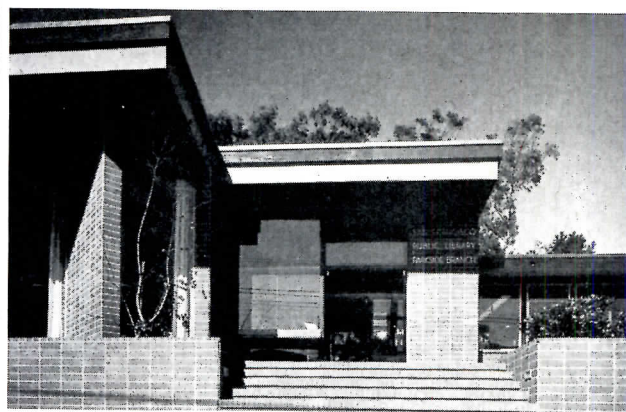
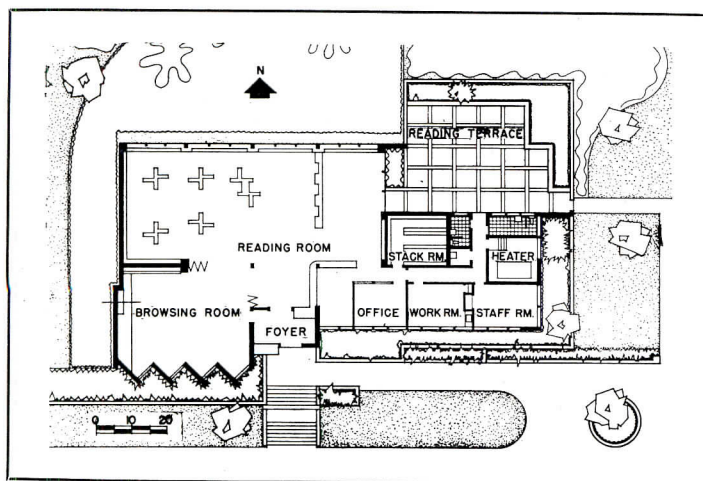

Music Develops New Building Types

Music, most universal of all arts, has always had its special buildings; now is developing new types, as witness this special building (below) for a school band. Participation is the new factor, and organized educational activities. Music is insinuating itself also into recreational buildings and parks, and is always asking for facilities, from the practice room in the school to the band shell in the park.

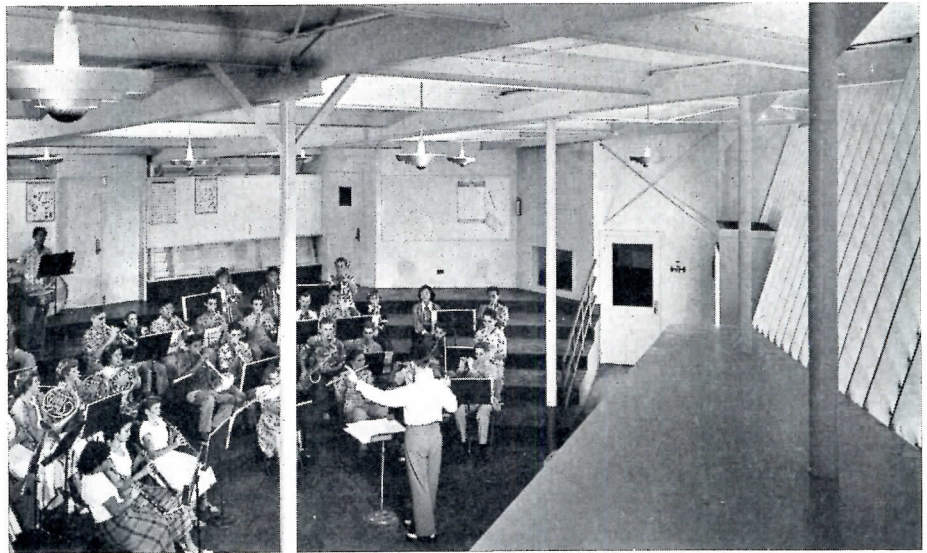
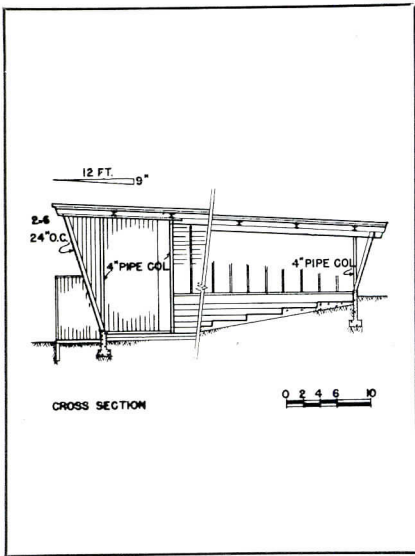

R. Wenkham

9 | **TRIANGLE BUILDING
BANDROOM, PUNAHOU SCHOOL
HONOLULU, T.H.**
Yoshio Kunimoto, Structural Engineer

Basic requirements for a school music department are compactly fitted into this uniquely shaped building. The triangular plan, set by the shape of the land available, was used to advantage to help the acoustic properties of the rooms. The contrasting slopes of walls, ceiling and floor — none being parallel, and only one wall perpendicular — helps kill excess reverberation, while the use of redwood is said to increase resonance for overtones. Upper walls and ceiling have acoustical tile.

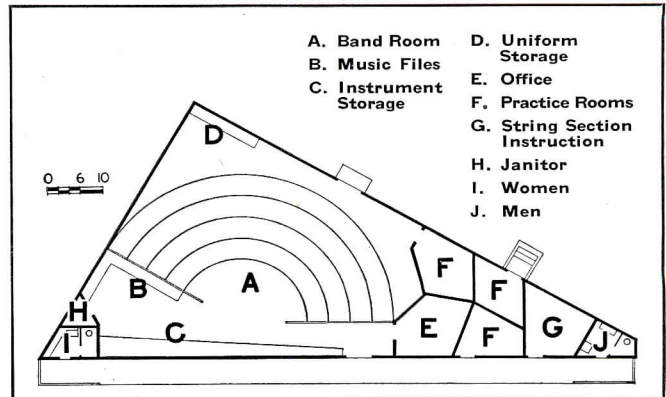
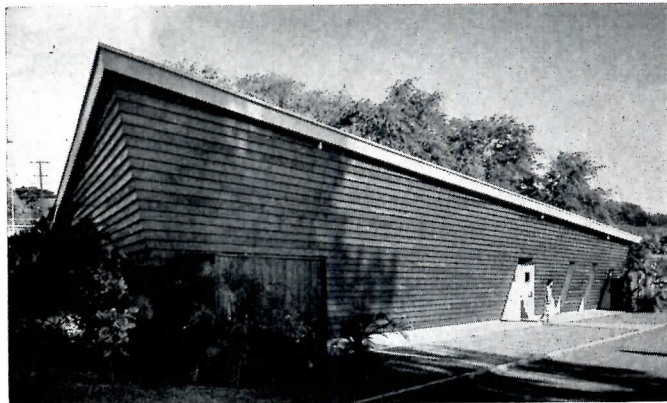

New Town Plans Integrate Recreation

10

CITY PLAN PROJECTS FOR LATIN AMERICA

Town Planning Associates:

Paul Lester Wiener and José Luis Sert

In the series of new and redeveloped city plans for Latin America by Town Planning Associates (see *Architectural Record*, August 1953, pp. 121-136), all recreational areas are treated as an integral part of the whole city by establishing a penetrating network of parks and parkways. The plan for Medellin, Colombia is a typical example; a diagram of its center portion is shown near right, with parks indicated by diagonal hatching. Whenever possible, the parkways ("D" on diagram) act as spinal columns for the different city sectors and are utilized, in part, for schools, sport fields, kindergartens and play fields. All parkways are for pedestrians only. Vehicular traffic ("F") branches into cul-de-sacs and, in most cases does not cross parkways; when unavoidable it crosses by overpasses. In new cities, there is little difficulty in establishing an integrated network; in established cities, existing streets are partially converted into parkways and correlated with new areas of the master plan.

In the case of Medellin, rivulets from the mountains surrounding the town are channelled and landscaped. This integrated park network provides a balanced distribution of open areas for all sectors of the city, and permits one to walk to nearby recreational facilities (or to most any part of the city), without leaving the parkways.

Each city has a main civic center to provide cultural facilities for the whole population ("A" on diagram and plan top right). In addition, there is a city-wide athletic center containing stadium and various facilities for major sports competitions ("B" on diagram), and several large parks ("C").

Cities are divided into sectors, each with its own civic nucleus of a church, movie, shopping center, library, etc. Sectors are divided in turn into neighborhood units for about 10,000 people ("E"). These units, too, have their own civic nuclei on a smaller scale. Groupings of dwellings or housing within these areas again provide play lots, kindergartens and some sport fields for the neighborhood populations. A typical example of such neighborhood units centered on a parkway is shown bottom right in a plan developed for Cuba.

Though there is no absolute standard, and each city has its unique problems, the firm tries to set aside from 5 to 10 acres per 1000 population for recreation.

A typical city-wide civic center set in a park area is shown right ("A" in diagram below)

LEGEND

1. Shops, Offices
2. Office Buildings
3. State Building
4. Library, Meeting Hall
5. Museum
6. Movie
7. Theater
8. Open Air Theater
9. Hotel
10. Bus Terminal
11. Cafe, Restaurant, Exposition Hall



A typical neighborhood unit right ("E" in diagram) has its own play areas, centers on parkway

LEGEND

1. School
2. Multi-Use Covered Area
3. Nursery
4. Administration
5. Experimental Gardens
6. Play Field
7. Children's Playgrounds
8. Shops
9. Cafe
10. Restaurant
11. Church
12. Covered Market
13. Open Air Market
14. Garages
15. Highway
16. Service Roads
17. Avenue
18. Parking

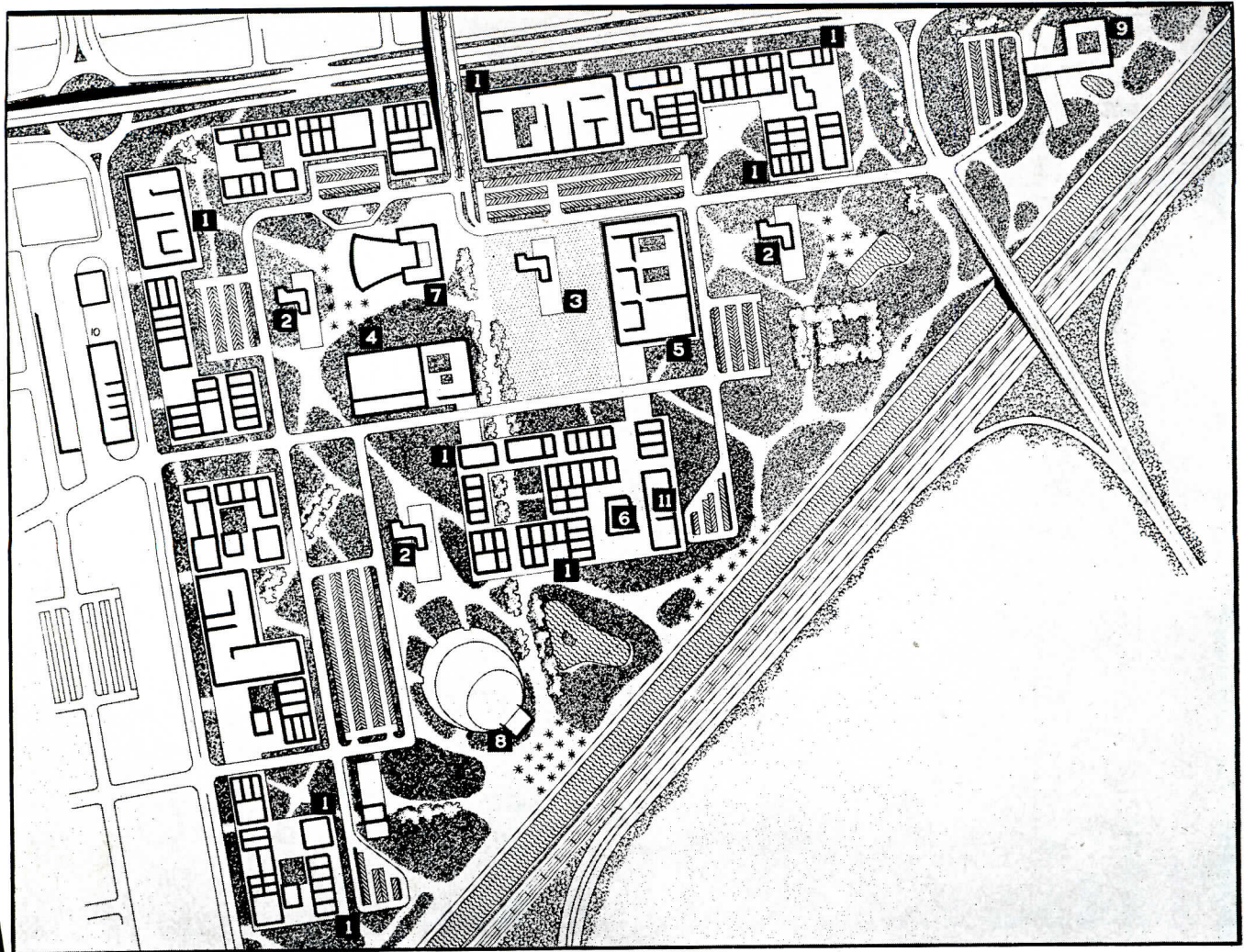

A

E

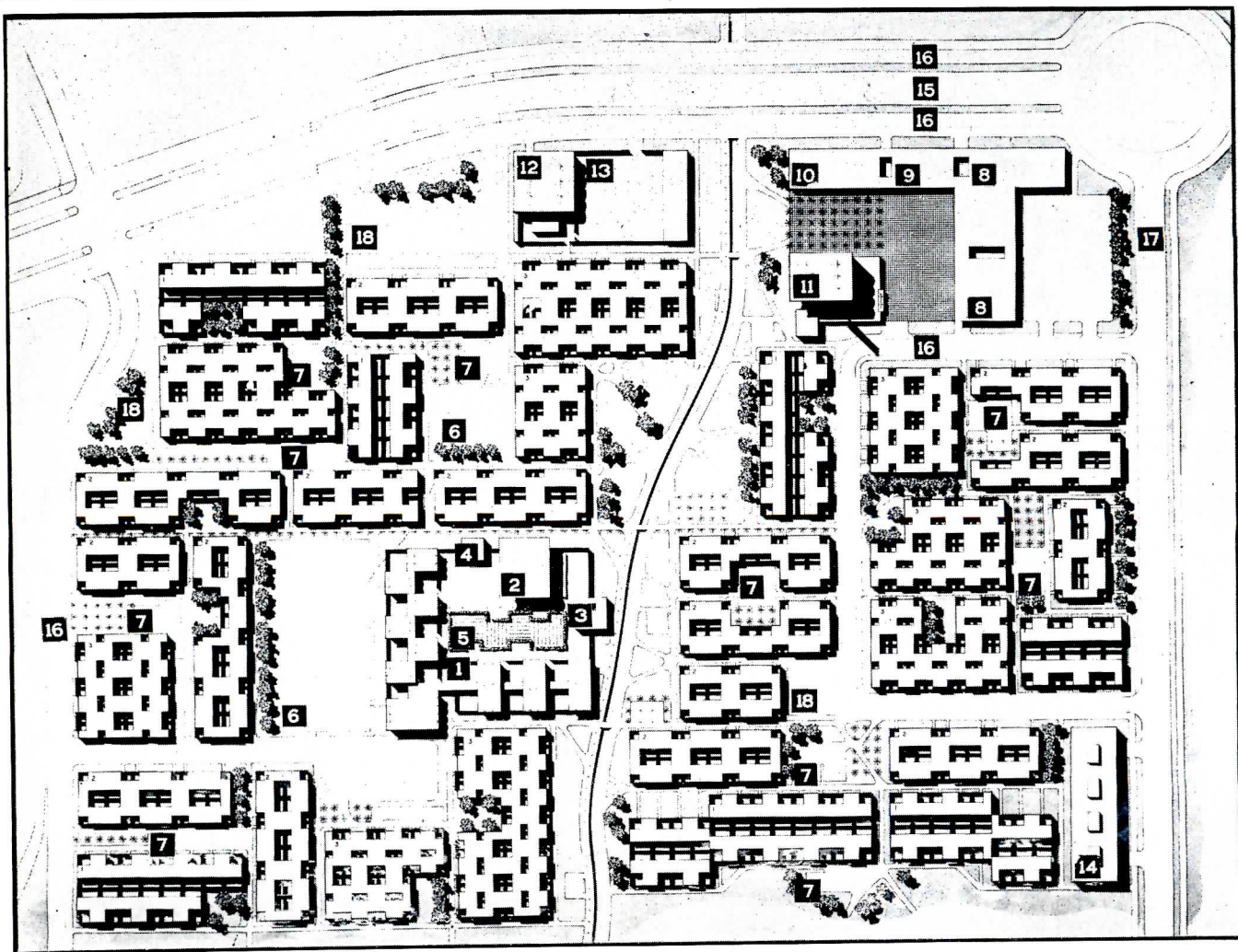

Water Sports Are Most Popular of All

Water sports are said to be *THE* most popular of all recreational activities. They beget buildings of many types — in resorts, yacht harbors, fishing camps, beaches, even city parks. Water sports seem to involve social activity as do few other types of recreation; maybe that explains their popularity. Swimming, for example, attracts lots of people who do very little swimming; indeed this has now been recognized in design of pool developments, with lawns and playgrounds and other things for those who just like to cavort in the sun in bathing suits.

Richard Shirk

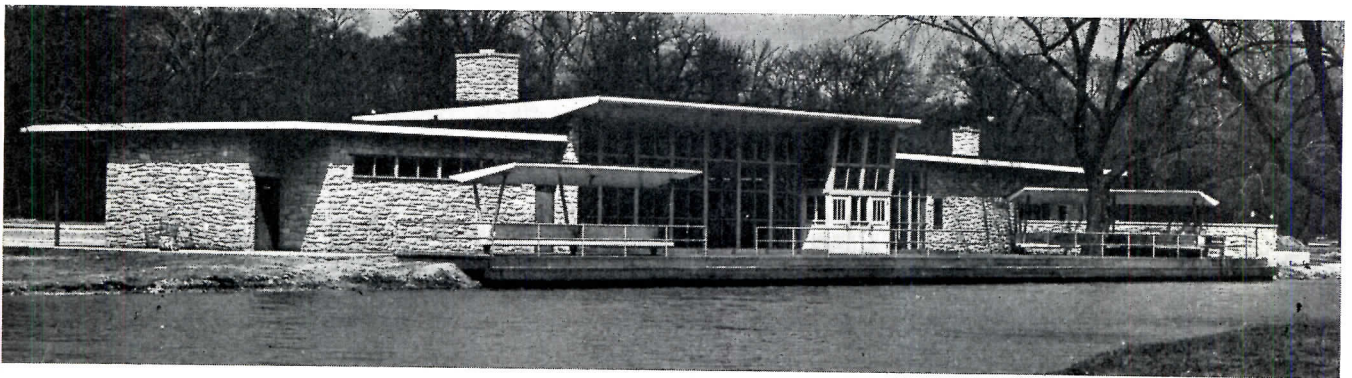

11

FLYNN MEMORIAL RECREATION PAVILION DETROIT, MICHIGAN

Swanson Associates, Architects

A lakeside site in a northern state gives a dual purpose to this pavilion — canoeing in summer, skating in winter. A large central lounge is flanked on the left by toilets, on the right by a lunch room, kitchen, office, skate checking facilities and a first aid station.

Richard Garrison

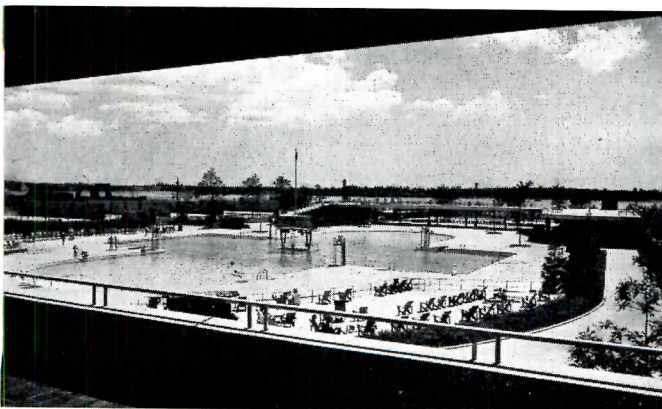

12

SHOREHAVEN BEACH CLUB BRONX, NEW YORK

O'Hara, Hedlander and Edson, Architects

The increase in the allotment of space for sun bathers can be noted around the main pool of this large beach club (above). A wading pool is provided for children. The building shown at right houses offices, lockers. The project also includes game courts and a band shell.

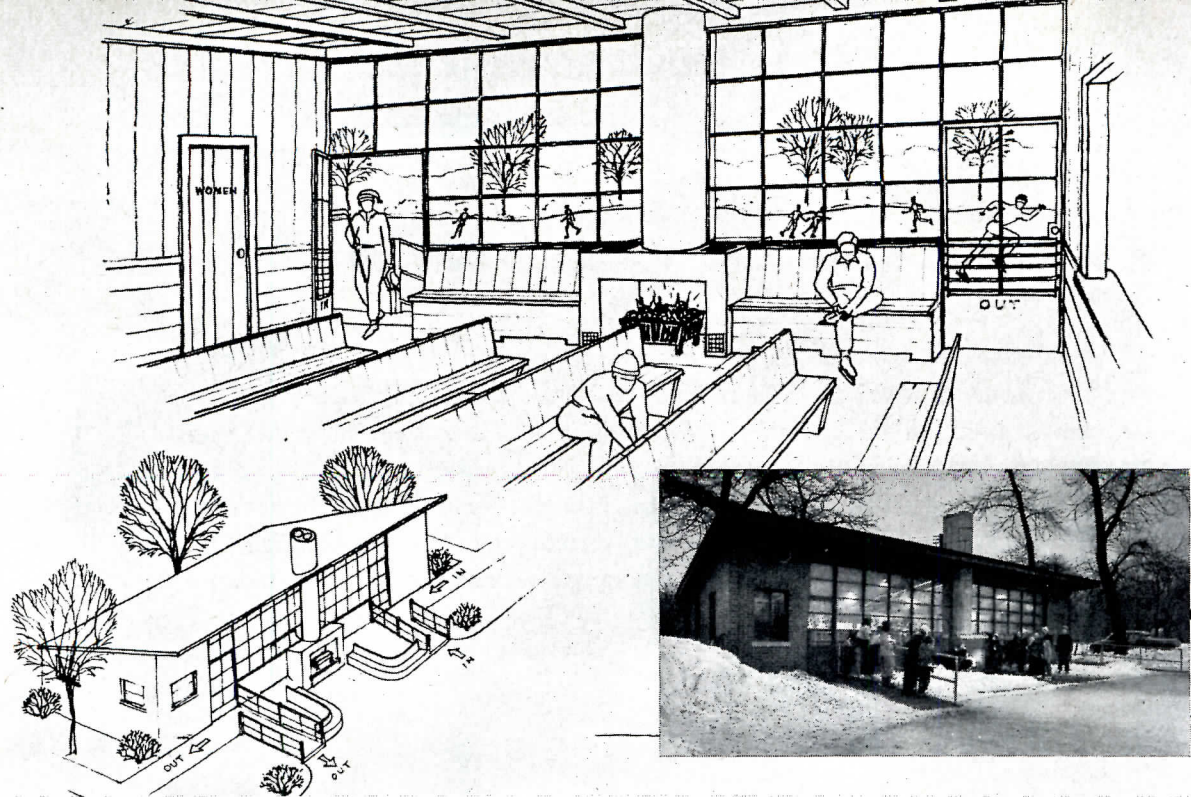

Hedrich-Blessing Photo

13

**SHELTER IN HUBBARD
WOODS STATION PARK
WINNETKA, ILLINOIS**

*Howard T. Fisher &
Associates, Inc., Architects*

A removable glass front gives a dual use to this park shelter. It serves as a convenient open pavilion in summer, a snug shelter for skaters in winter. Portable freezing units have been used in similar set-ups, because of warmer winters; they are sometimes used over tennis courts. Other places use permanent installations.

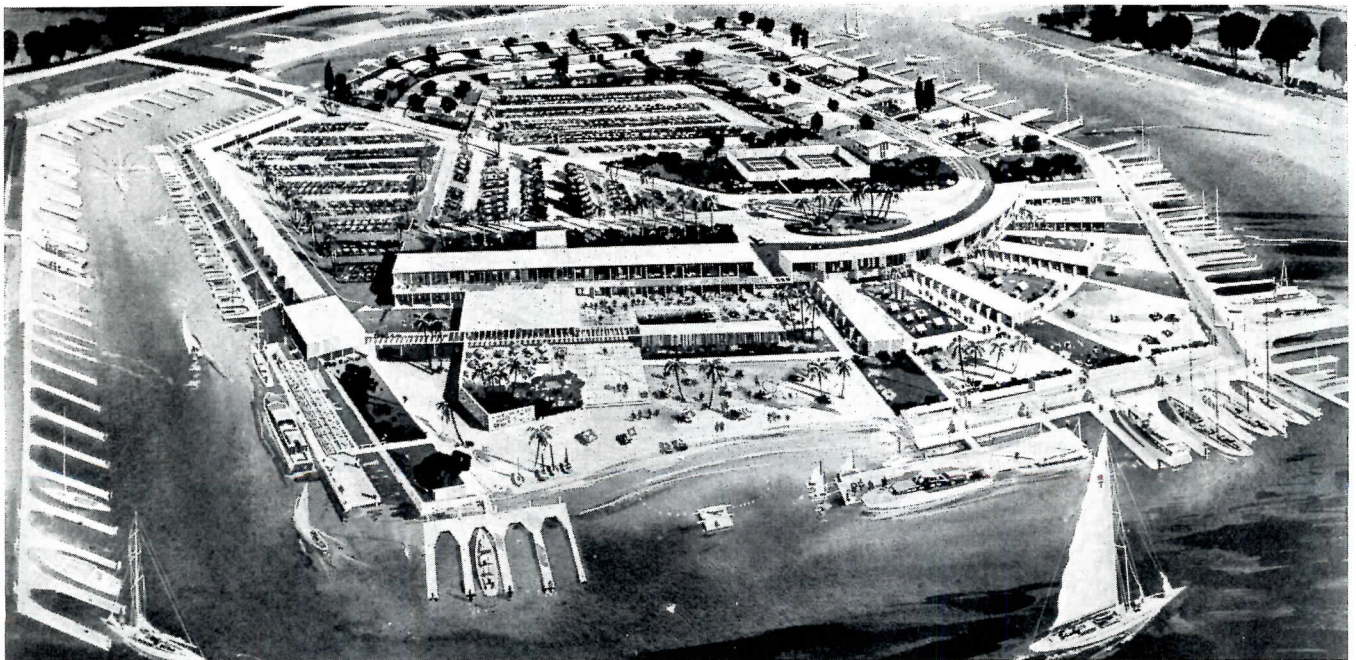

14

**PUBLIC BEACH RESORT
LINDA ISLE, NEWPORT
HARBOR, CALIFORNIA**

Welton Becket & Associates, Architects

Water-sport, yachting and seaside enthusiasts will find a bonanza of facilities in this island project: beaches, a pool, boat slips, and living, dining and amusement establishments. The rear portion of the 27-acre island will be divided into 61 lots for private homes.

Museums, Too, Try the New Trends

Museums and art galleries were once altogether too stuffy to qualify in the category of "social and recreational." But they are catching on. The new idea is to popularize them, in a nice way, of course. A junior department is one stunt, along with special showings or topical exhibits. Smoking rooms are appreciated here too, and cheerful restaurants, and better lighting and more intimate displays. A few museums are even breaking out with picture windows, to reduce that feeling of being merely storehouses of ancient paintings. The participation idea is working here too.

15

**METROPOLITAN
MUSEUM OF ART
NEW YORK, N. Y.**

A large portion of the Metropolitan Museum will be reopened in the near future, and will reveal a brighter, lighter series of galleries to its patrons. The general lighting level has been raised by various combinations of indirect, spot and down lights. Large windows have been placed to capture vistas through surrounding Central Park. New smoking lounges have been spotted through the galleries. Visitors' enjoyment should also be increased by the relocated restaurant: an existing colonaded gallery is being fitted with fountains by Carl Milles and decor by Dorothy Draper. An auditorium addition, designed by Voorhees Walker Foley & Smith will be flanked (below) by galleries of related exhibits.

THE NEW RESTAURANT

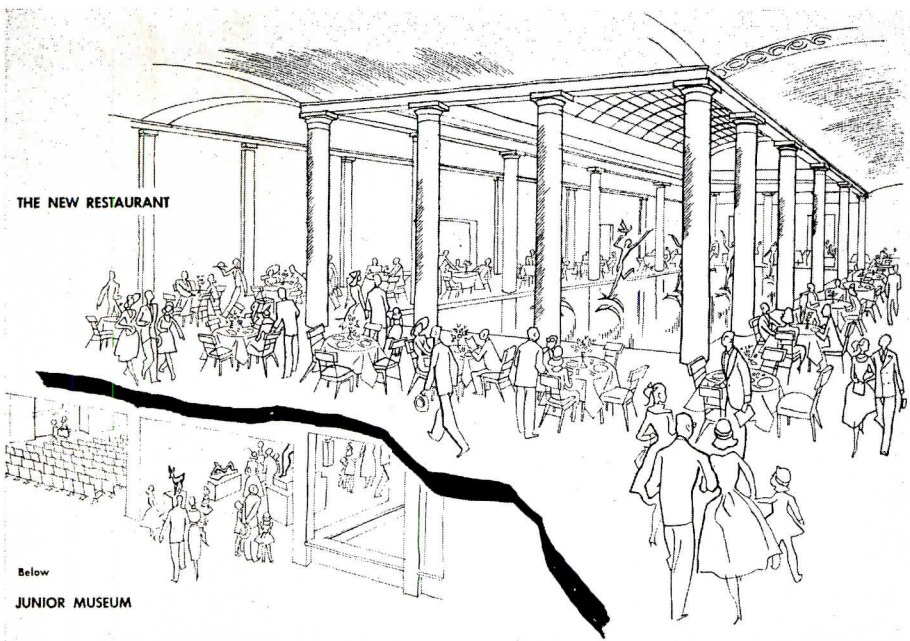

Below

JUNIOR MUSEUM

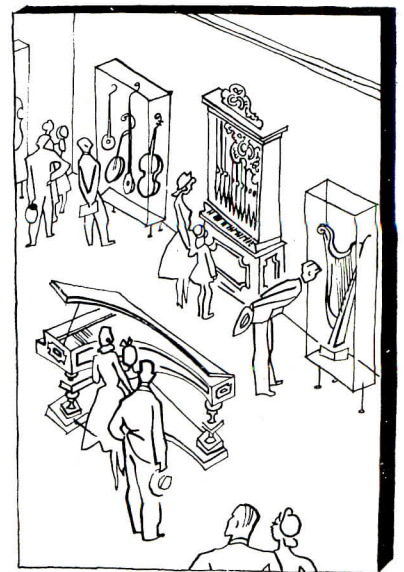
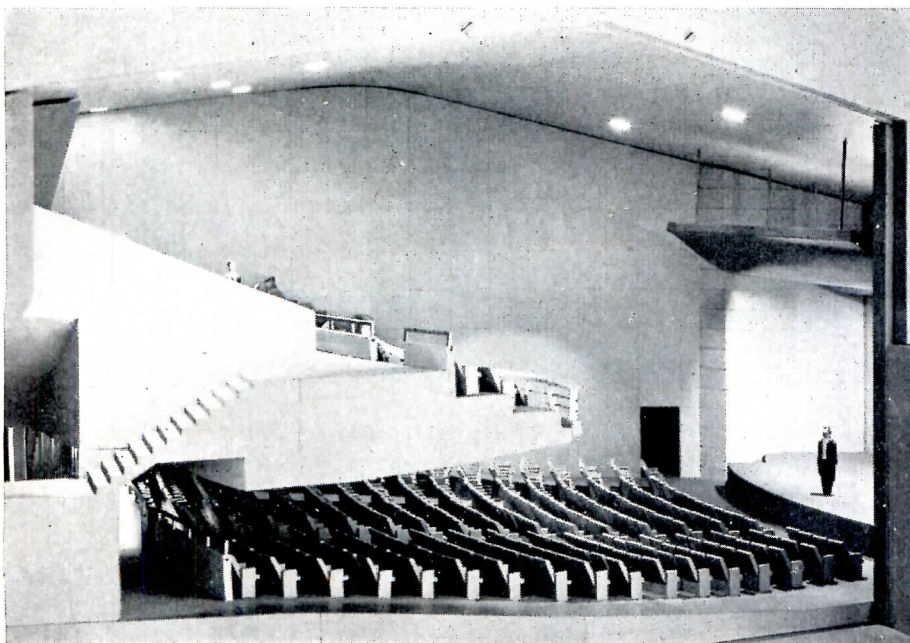

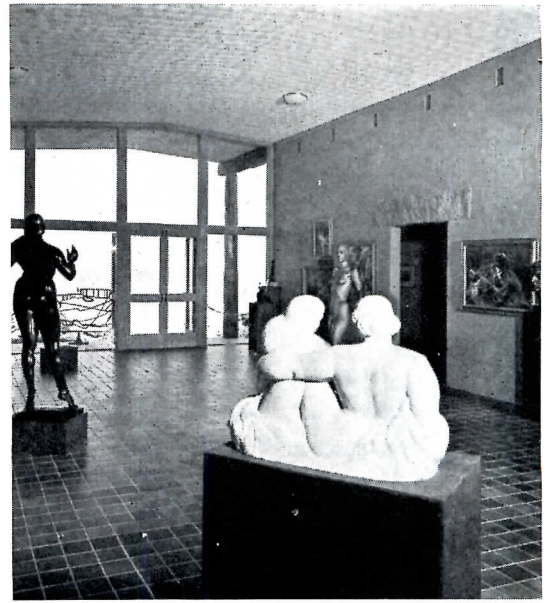
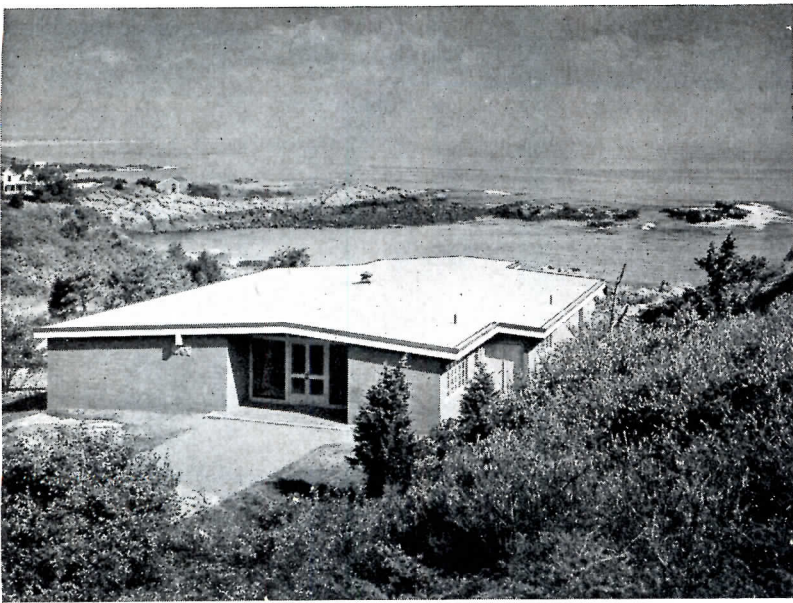

Joseph W. Mollitor

16

**MUSEUM OF ART
OF OGUNQUIT
OGUNQUIT, MAINE**

*Charles Worley, Jr.,
Architect*

The trend to get away from the "bank-vault" atmosphere often associated even with small museums, is clearly reflected in the design of this little building (above) for Ogunquit. The large central foyer, which serves as a sculpture court, has glass walls at each end to permit a view of the precipitous sea-cove below as one enters the building. The building contains three other galleries, and was planned as a cultural center for the community.

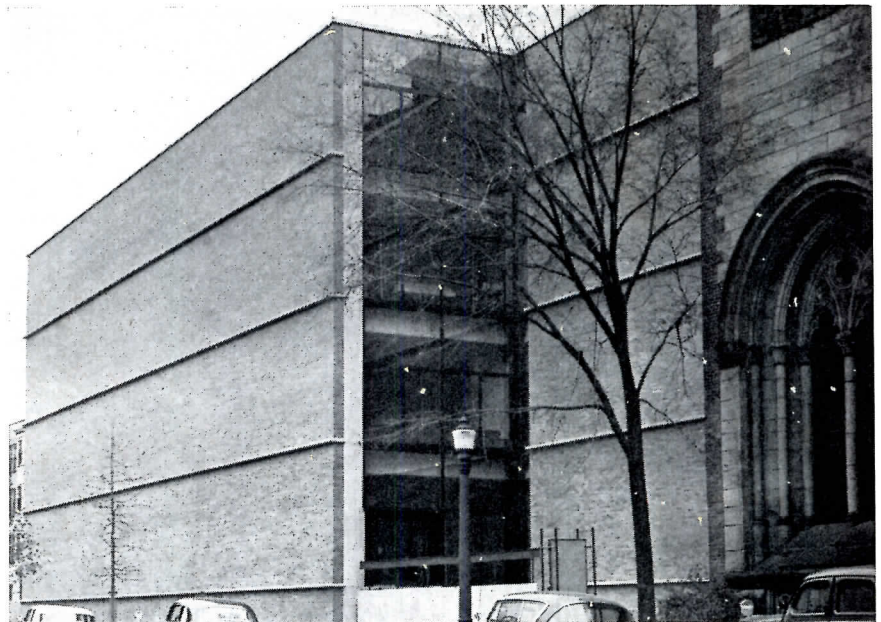

17

**ART GALLERY,
DESIGN CENTER
YALE UNIVERSITY,
NEW HAVEN, CONN.**

Louis I. Kahn, Architect

Yale's recently dedicated art center (right) could perhaps be best described as a working museum. The structure will be used both for gallery purposes and for art, architectural, city planning, graphic arts and other classes. Construction elements and materials frankly dominate the design — all but the floors are left unfinished and exposed. Ceilings are formed by a unique system of cellular reinforced concrete slabs forming tetrahedrons, contain utilities.

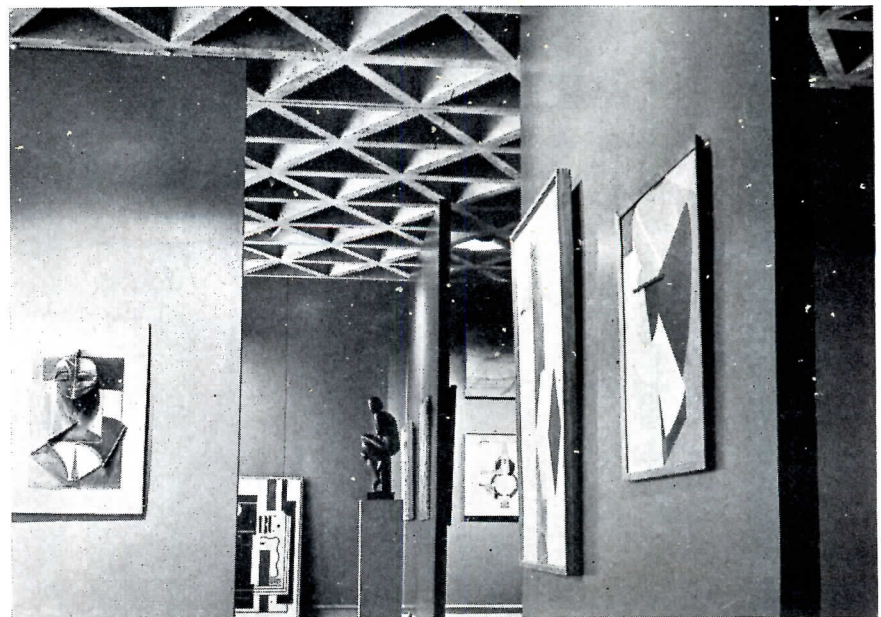

Alburtus Yale News Bureau

Theaters Fight TV With New Appeals

Theaters are not now as active as other types, but they are not dead yet. Newer ones are more social, more recreational, more comfortable. They are adding many new attractions besides popcorn and 3D, all with the idea, as Burchard says, of less specialization and more enjoyment. One suspects that the social aspects of the theater, perhaps heightened somewhat, are the best weapon against TV.

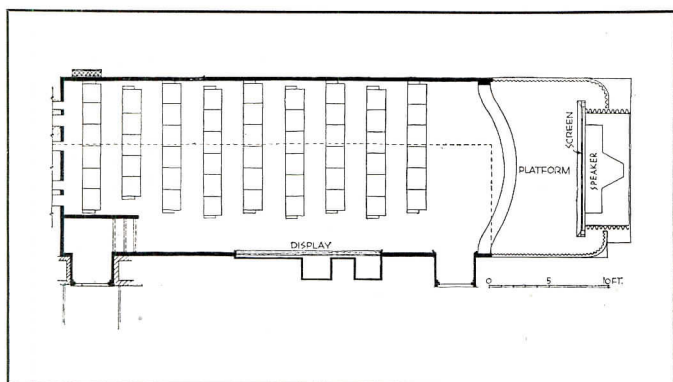

18

**PARAMOUNT
PREVIEW THEATER
NEW YORK, N. Y.**

Reisner & Urban, Architects

This screening room in New York's Paramount building holds much in common with many of the little "art theaters" which are gaining popularity across the country. A faintly elegant simplicity is combined with maximum comfort to provide a background for the patrons to see the movies, themselves and exhibits of paintings.

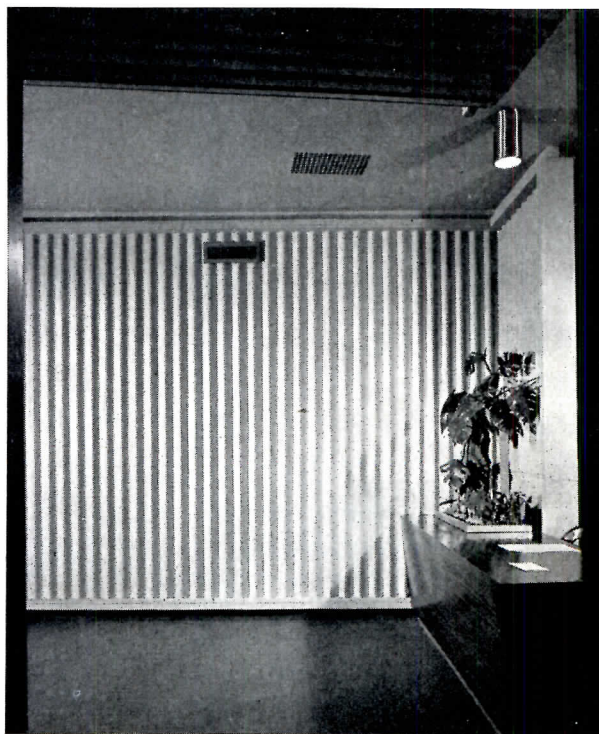
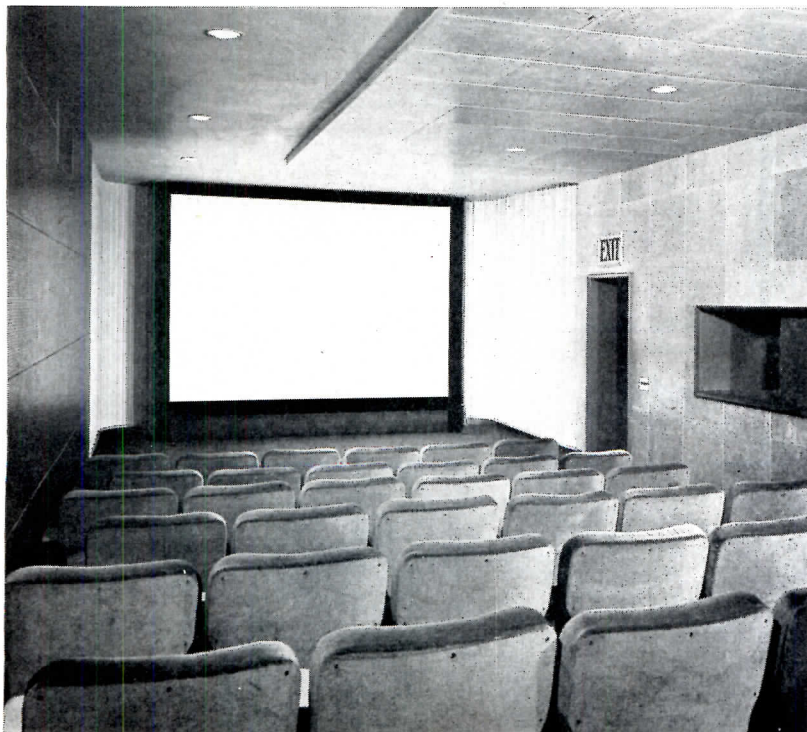

THE STRUCTURES THAT HOUSE US

By Fred N. Severud
Severud-Elstad-Krueger, Consulting Engineers

Familiar to most of the readers of the Record is the author's use of analogies taken from nature to make structural principles clearer and more vivid. Much of Mr. Severud's engineering philosophy is manifested in these examples. With articles such as this he hopes to stimulate more imaginative expression of structures.

IF I WERE TO SPEND a number of days in the library, poring over books written about the human body, I probably would find much information on the points I would like to bring out. Nothing would please me more. However, time is a hard taskmaster, so I have decided to do the best I can on the basis of my own observations of some of the marvels of the human body as a structural system.

I realize full well that my own appreciation of its harmonious integration is thoroughly inadequate, and also that describing this in technical terms instead of expressing it in exultant poetry may be questionable. I believe, though, that even a crude and very limited presentation may provide incentive to dip into this seemingly inexhaustible reservoir of demonstrations of structural problems masterfully and brilliantly solved. In our awkward and clumsy fencing with gravity, we might well acquire a deep sense of humility, if no more, by attempting to get insight into how the Master does it.

Drawings were prepared by Raniero Corbellelli
and Joseph G. Merz who worked
in close collaboration with Mr. Severud on this study

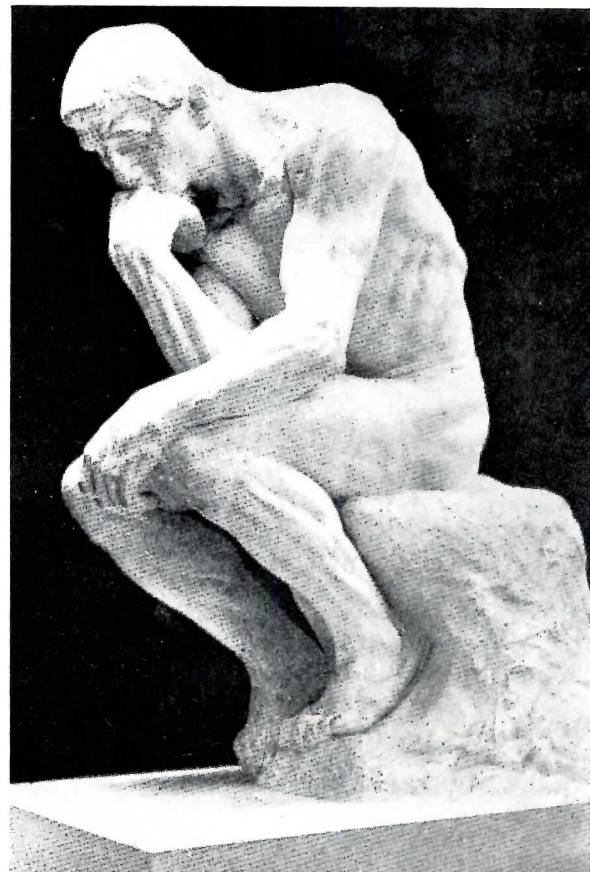

"The Thinker"
by Rodin

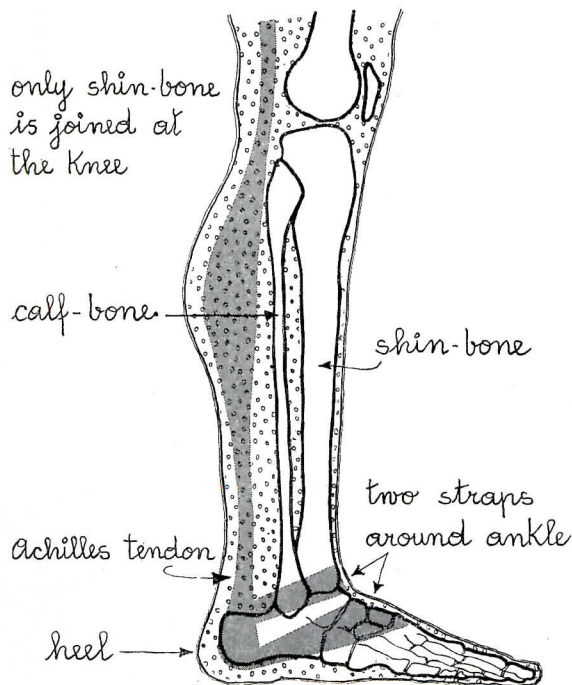
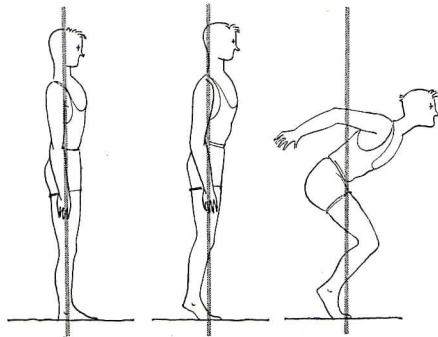
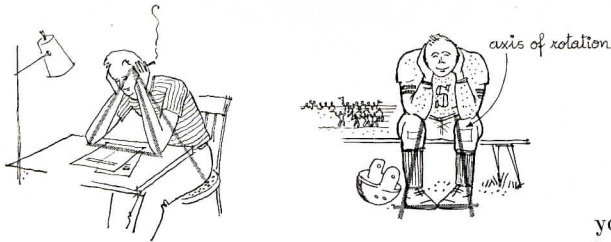

If you read this article with concentration you may lean your elbows on the desk with your head propped on your hands, as in the small sketch. Did you ever think about what a nice space frame you have instinctively provided, which allows the head to be perfectly still and relaxed for concentrated thinking?

Friction between the elbows and the desk will prevent the arms from slipping, and thereby ties them together. Now, if a desk is not available and you still want to concentrate, you might take the posture immortalized by Rodin in his statue of "The Thinker." However, if you desire a greater sense of security you would need some lateral stability in order to not be dependent upon the perfect line-up that this posture requires. So the posture shown in the sketch with both elbows resting on the knees, is more stable, though admittedly less graceful.

Since there is no tie to prevent the elbows from spreading, something must be done to keep the knees in place. This can be done by a muscular arrangement, but this muscular exertion can be greatly minimized by turning the feet with the toes inward, in a pigeon-toed manner. This puts torque on the calf and shin-bone arrangement which we will hear more about later, and this torque will oppose a certain amount of outward movement of the knees. The axis of rotation is a line drawn from the heel to the hip.

Let us ramble along a little further and examine some other aspects of our own fantastic domicile. What is wrong about being flat-footed? Why the expression: "Get on your toes?" To "Get on your toes" might well be changed to: "Float your heels." The body weight is carried from the knee into the shin bone which delivers it to the ankle. The ankle acts as a fulcrum, and the position of the foot about this fulcrum is governed by the calf muscles which are connected to the Achilles tendon from which the heel is hung. This tendon is anchored by being strapped around the ankle. If we move the body weight forward so that the center of gravity falls above the toes, stability is attained even when the contraction of the calf muscles makes the heels airborne.

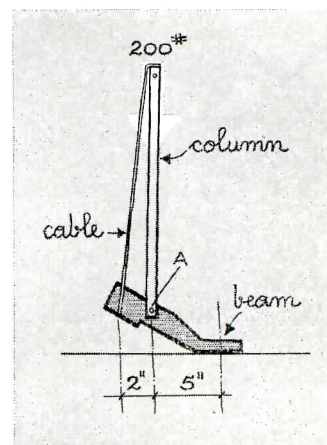



To better formulate a mental picture of the magnitude of the forces at play, a few calculations may be helpful. The analysis is simple, but simple analyses give good training in fundamentals.

What is the approximate force in the shin bone of a 200 lb man standing heel-hung on one foot? If we simplify the structural system and assume weightless members, this is about the problem, pictured in the simplified sketch of the leg and foot:

Cantilever moment around "A" is $200 \text{ lb} \times 5 \text{ in.}$, or 1000 in.-lb. The same moment must exist on the other side of "A" so the pull is about $1000 \text{ in.-lb} \div 2 \text{ in.}$ or 500 lb, ignoring slight slopes. This force of 500 lb tends to shorten the shin bone. The weight at the knee has the same tendency, so the combined force on the bone is 700 lb in compression. Does it surprise you that you carry 350 per cent more load on your

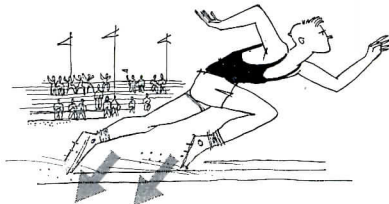
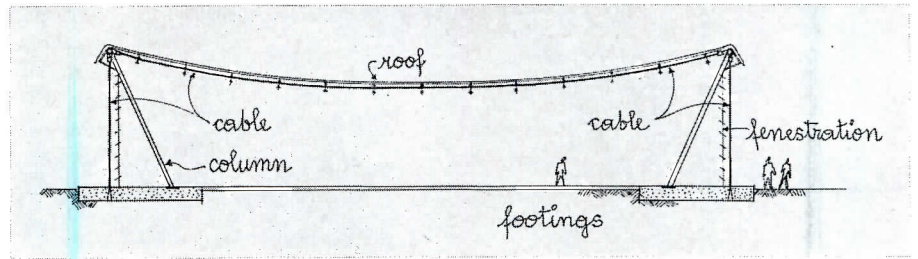
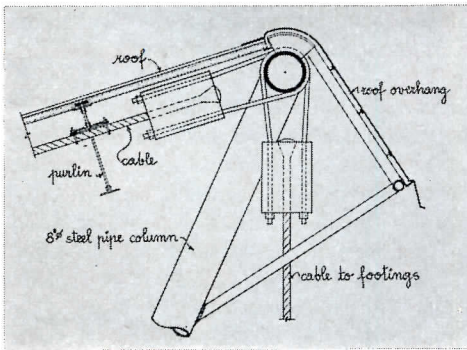

shin bone when your heels are hung? You don't believe it? Try it on one foot with a girl in your arms!

An application of the general leg-foot principle is used in the sketch for a projected factory roof. Here the pull from the catenaries is resisted by the concrete floor, acting in compression. The force is brought into the floor by a slanting "shin bone." The anchor cables act as Achilles tendons and the footing is, of course, the foot.

Mathematics aside, what do we gain by airborne heels? We have "prestressed" the shin bone and are ready to snap into action. We can admire the sprinter who, by increasing the pull in the calf muscles many-fold, whips his toes against the ground and covers a hundred yards in close to 9 seconds. In the excitement, even we might have floating heels.

Sprinting is quite a punishment for the shin bone. If, even standing still, the force is 350 per cent greater than the body weight, isn't running disastrous? Fortunately, the shin bone has a "side-kick," the calf bone. But it cannot have been designed to carry much load because it is indeed a "side-kick." It is very casually, or so it seems, connected to the shin bone at the knee and at the ankle.

In plan, the assembly is something like this: The rectangular shape of the shin bone makes it very efficient against buckling in the front-back direction. Sideways it is quite flexible, but it is held in place by being connected to the calf bone. This is also flexible, but the interosseous membrane ties them together to give the proper buckling resistance in this direction also. The membrane is somewhat elastic so the shin-calf-bone-membrane team provides a strong, yet elastic column with spring action. For heavy shocks both bones bend ever so slightly, putting a stretch in the membrane until the main impact subsides. So between being heel-hung and spring-column-mounted, our underpinning is ready for a jump from the apple tree.

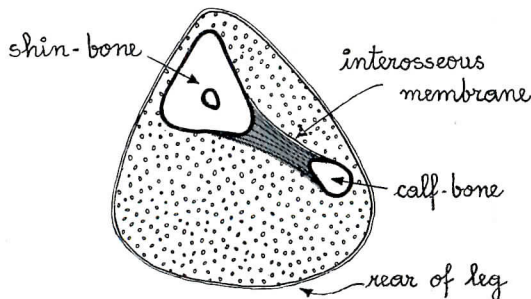



means $490 \text{ in.-lb} \div 1 \text{ in.}$, or about 490 lb in the tendons and the muscles pulling them. We find about the same pull in the under-arm muscles as in the calf muscle. But try to get on your fingers on one hand. If you can do it, you are pretty good, but this stretch is about all the muscle can take, whereas getting on the toes is done without conscious effort.

We see then that the two systems: (1) the foot, a double cantilever with a projecting heel for greater leverage, and (2) the hand, a single cantilever with a relatively small effective depth, have been carefully proportioned for the job each has to do.

Let us move on from a study of single members to an assembly, the torso-arm structure, which we will find of especial interest. What happens at the top of a push-up? For freedom and flexibility the arm is practically loose, being connected by a hinge at the top of the shoulder blade. This shoulder blade is in turn "floating," guided only by muscles and the collar bone, which is double hinged. What would life be like without the shrug of a shoulder? But this whole seemingly loose affair creates a stable support when the muscles are brought into play.

The main supports for the rib cage are the breast muscles. These are attached to the arms at the shoulders and act as catenaries, or cables. The structural system takes either of two forms: (1) the muscles between shoulder blades and rib

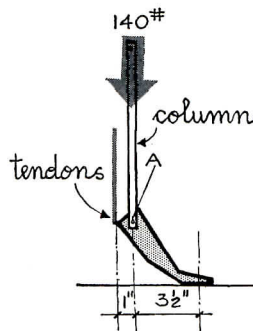
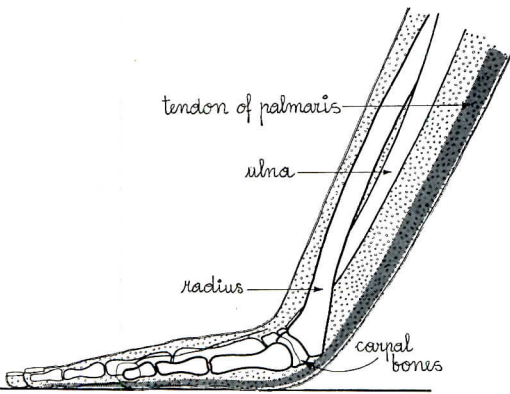

But now back to the toes. It is interesting to make a comparison between getting up on the toes and getting up on the fingers. The feet and the hands have many similarities. Obviously, the foot gets more punishment. Let us see how this is reflected in structural characteristics.

In the hand, the heel is conspicuously missing. Instead of the double cantilever system of the foot, the hand is a single cantilever from the wrist.

Let us make some calculations again, just to get the scale of forces in mind. If we assume 70 per cent of the weight on the arms, our same 200 lb friend carries 140 lb on the hands in the position of a push-up.

Now let him move over to carry all this weight on one hand, and then "get on his fingers." Here is the problem: the moment about "A" is $140 \text{ lb} \times 3.5 \text{ in.}$, or 490 in.-lb. The tendons in the wrist are about an inch away from the top of the bone. This



cage are slack; or (2) the muscles are taut (see sketches).

A mathematical analysis gives the interesting result that the pull in the breast muscles is the same as the total load carried by the arms. For a 200 lb man this is about 140 lb. Comparing this pull to the 700 lb taken with the greatest of ease by the calf muscles, we can appreciate the beautiful balance in the body between use and strength.

The rib cage idea applied to a structure is shown in sketch form and could very well be used — perhaps it has — where large, unobstructed spans are required.

Now I should like to outline a few simple exercises with the body as a whole, which will enable one to get a "feel" of the flow of stresses in various structural forms created for our battle against gravity. Most of our problems require not

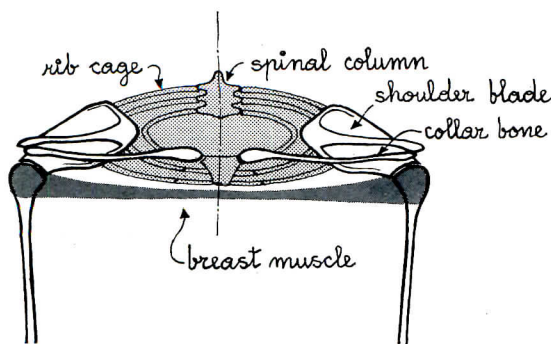

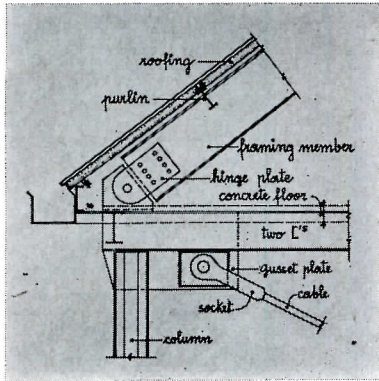
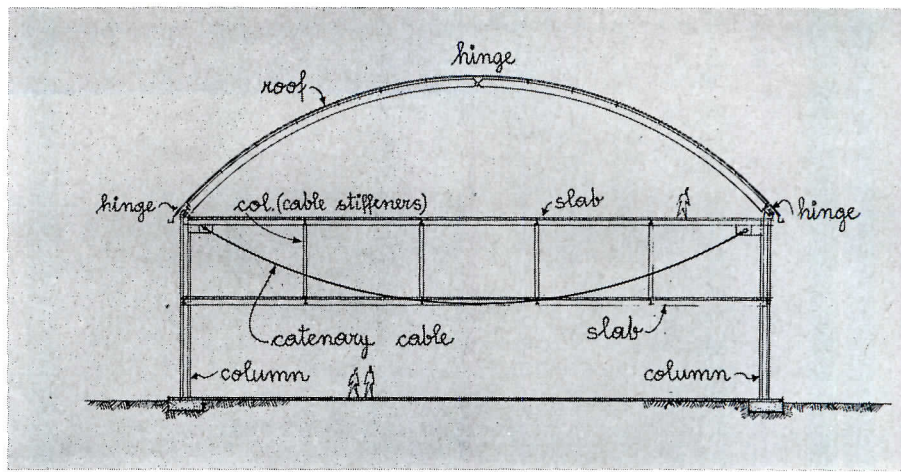
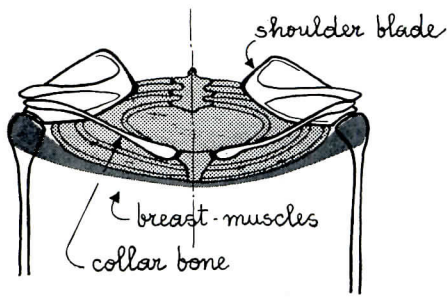

only the interruption of gravity pull at a certain level, but also the enclosure of space and the carrying of loads at the same time.

Let us try some simple gymnastics with the body weight alone. First, lie face down and relax all muscles. This is the most efficient way to satisfy the gravity pull.

Now take the head, for instance, when one goes to bed. Instead of loading spine, pelvis, and legs, it surrenders itself without stalling to the pillow. Without struggle there is peace, so this is the condition of truce, with a blissful sense of surrender, until the alarm clock breaks the spell.

To create enclosure there are various ways the body can perform with hands, knees and toes on the floor. For simplicity let us consider the knees and toes as one column each. If the toes are lifted from the floor, a balanced cantilever condition is created. It is not uncomfortable. Of course, the pressure under the knees increases, since more load is carried here than before. But let the toes down again and lift the knees — a radically different set of stresses is induced. Carrying the body weight over the greatly increased span, with the head and neck as a cantilever, begins to be a real chore, and one can't endure this position too long.

To get a further insight, place any kind of a load on your back. The greater load intensity now emphasizes the nature of the stress. First try the hard way, with the body in beam section. Here the pull in the "front" muscles, resisted by compression in the spine creates a system of balanced tension and compression.

By "falling through" a catenary system is created and the stresses are greatly relieved because the construction depth is increased. The "front" muscles act as a catenary. Here is the well-known arch principle. But it becomes better understood if you try it yourself and realize the great relief it affords.

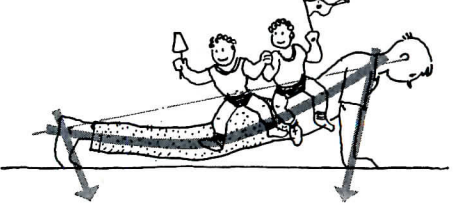
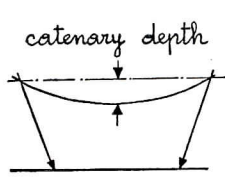
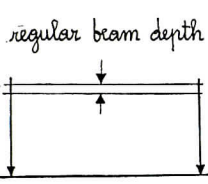
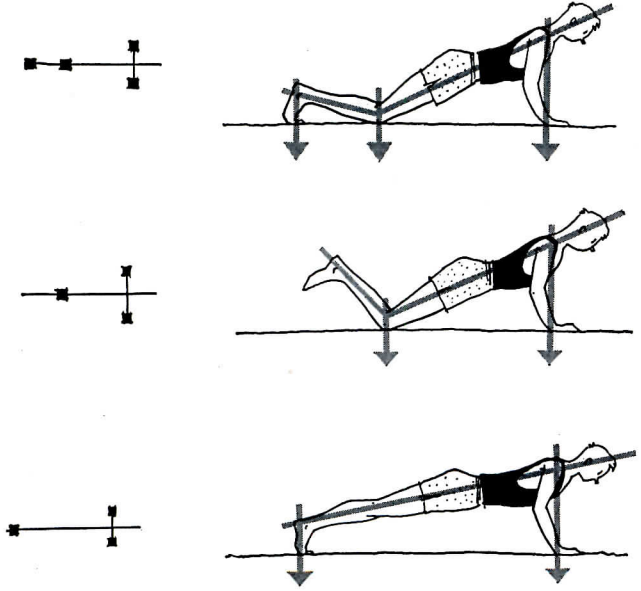

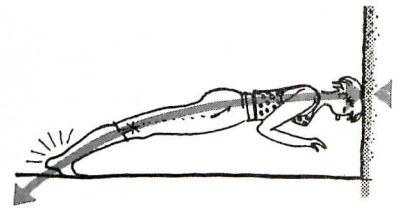

This gives the maximum construction depth of which one's body is capable, except if you become half an arch by standing up against a wall. Here the shifting back and forth of the feet gives an accurate feel of the relation between a flat and a steep arch. At the lower levels pressure on the head is terrific; or the feet may slide.

A more dramatic experiment with the catenary principle is a tug of war. It speaks for itself. The tension in the arm is resisted by the body as an inclined column, leaning way back to eliminate bending as much as possible. A good example is the North Carolina State Fair Pavilion.

A more complex experiment was very useful in settling an argument about whether or not a stair like in the sketch below is stable. You will soon find out in the human analogy that the axis of rotation goes from the right heel to the door knob. This makes it inclined and the body rotates to the left. Now put a stick from your left hip horizontally, and parallel to the door, to a nearby partition, and it becomes obvious at once how stability can be attained in a direct manner. The stair could be built without lateral support but would require sufficient reinforcing steel to take the twisting action.

Now let me ask you a simple question. Where is the most efficient place to carry change (structurally speaking, that is)? In your jacket or pants pocket (say you wear a belt). In the jacket, the load is carried to the shoulders and travels through

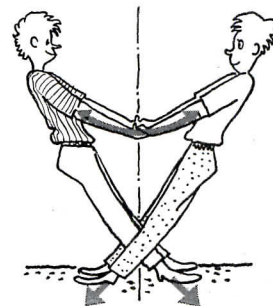
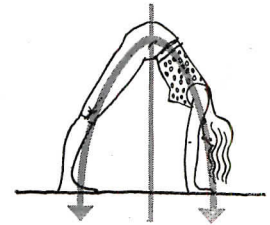
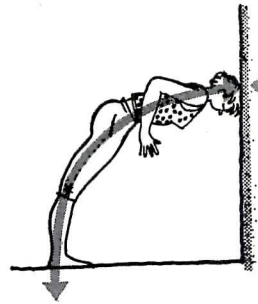

Jefferson Memorial Arch
Architects: Eero Saarinen and Associates
Structural Engineers: Severud-Elstad-Krueger

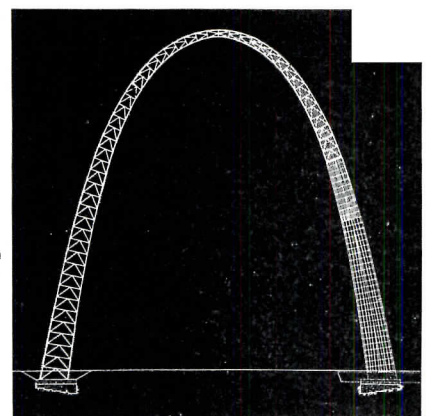
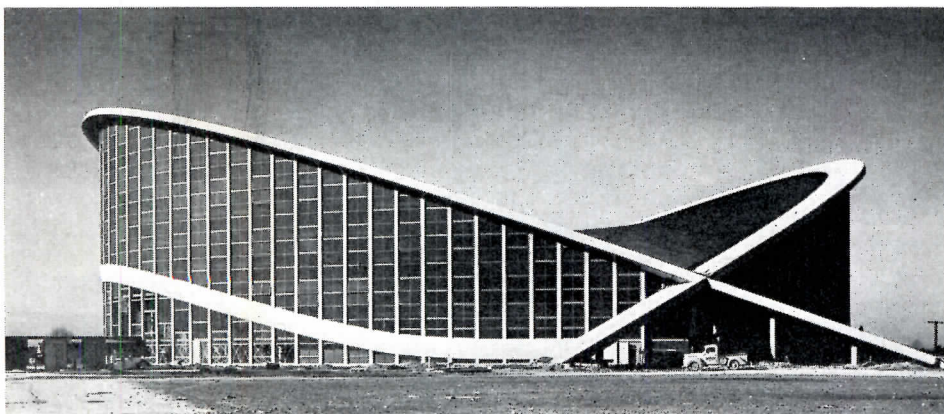

North Carolina State Fair Pavilion
Architects: Matthew Nowicki and William Dietrich
Structural Engineers: Severud-Elstad-Krueger

the full length of the spine. From the pants pocket it goes up to the belt and the hips. A whole spine has been saved and short-circuited.

Of course, the most efficient (although surely not very practical) way to carry it is in your shoes, so that when you are standing still, both spine, legs and feet are saved and when you walk only the legs carry the load.

Facetiousness aside, I urge that the crowning work of earth's creation be subjected to a comprehensive "structural" and "architectural" analysis.

In the meantime, it is hoped that this hastily composed scherzo may be a reminder that we are living within a frame that is "fearfully and wonderfully made."

Why not be your own testing laboratory? It asks so little and yields so much.

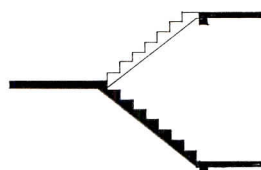
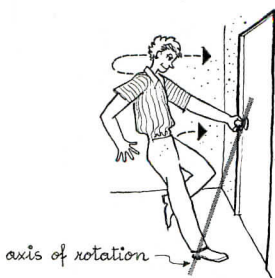

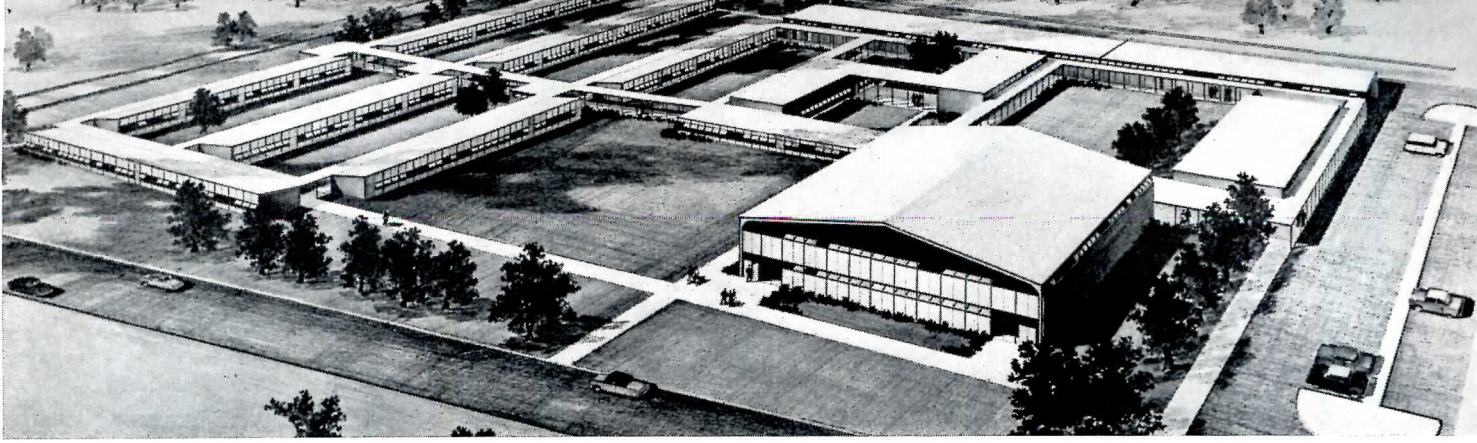

TIP-UP STEEL FRAMES FORM CLASSROOM WALLS

Moultrie Senior High School
Moultrie, Georgia
Associated School Architects

STEEL FRAME WALLS, tipped up into place, and exposed steel columns and beams account for most of the cost savings in this school. Since exterior walls are only 2-in. thick, extra classroom space has been gained. The Moultrie school has a total area of 62,500 sq ft, with costs running about \$8.50 per sq ft.

The side walls are frames fabricated from split Junior Beams, and are made

up entirely in the shop. A cement-asbestos sandwich panel forms the spandrel, an architectural projected window is set in the middle for ventilation, and opaque glass is placed in the upper section.

The frame is brought to the job completely fabricated, with panels and sash already in place. Then the entire frame is tipped up, tack welded to columns and top angle, and caulked. Glazing com-

pletes the work on the wall section.

Since the architects were concerned as much with hot as with cold weather, the school was designed with open corridors. Most classrooms have their largest glass exposure facing north, and small, high windows on the south, protected by the covered corridor.

Classrooms are heated by the warm air perimeter method, air entering the rooms through baseboard units.

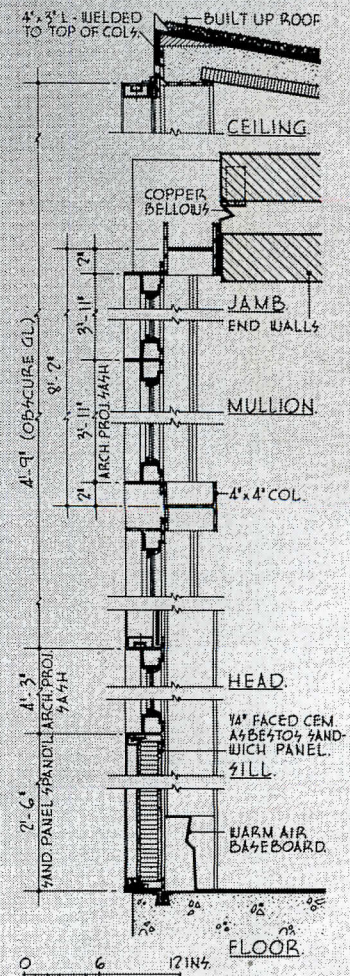
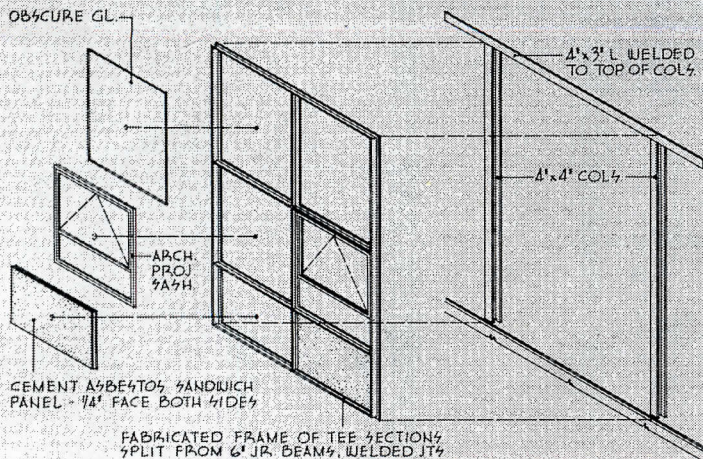
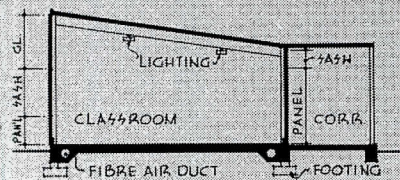

PRODUCT REPORTS

Materials / Equipment / Furnishings / Services

SOME RECENT

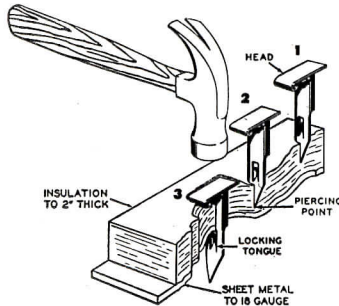

Left: fire-retardant roof uses special clips (above) to apply insulation without mopping to steel deck

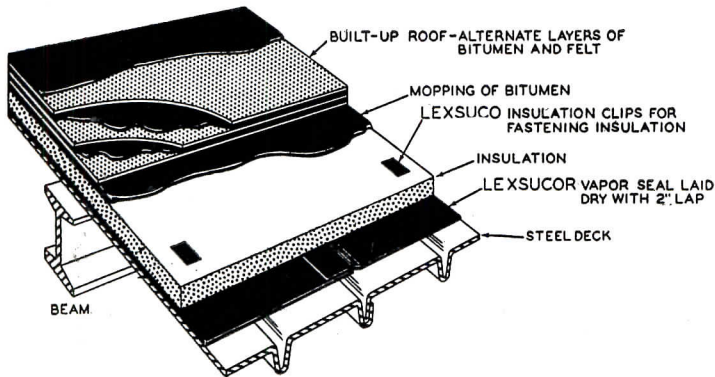

• A new type of fire-retardent roof construction has been developed to improve the fire resistant qualities of industrial roofs. *Lexsuco* roof is designed to (1) prevent dripping of inflammable asphalt or tar, (2) eliminate all combustible materials between roof deck and insulation and (3) improve roof rigidity, thus minimizing buckling of the steel roof deck during a fire.

The new features of this roof are (1) special insulation clips for fastening rigid or semi-rigid insulation mechanically to steel roof decks and (2) the *Lexsucor* vapor seal. The clip is designed to pierce metal decking up to 18 gauge with the use of an ordinary hammer.

With the special clips, insulation is applied to the steel roof deck dry. Mopping is eliminated, preventing the possibility of tar dripping through the deck to add fuel to the flames. The *Lexsucor* vapor seal is of fire-retardent Koroseal designed to deteriorate if a fire is present but not to support combustion. *Lexsuco, Inc.*, 4815 Lexington Ave., Cleveland 3, Ohio.

• *Tectum* is a new roofing material made of wood fibers, chemically treated, and bonded together with an inorganic cement. It is currently used for commercial, industrial and school roofs, but other applications are being studied.

Claimed to be structurally stronger, in many ways, than plain concrete, it has a high insulating value, good acoustical properties and has passed Underwriters' Laboratories tests for incombustibility. The material is also claimed not to rot, weaken with age, or appeal to a termite. It can be sawed, chopped or drilled. The panels also feature light weight, low cost and good light reflection.

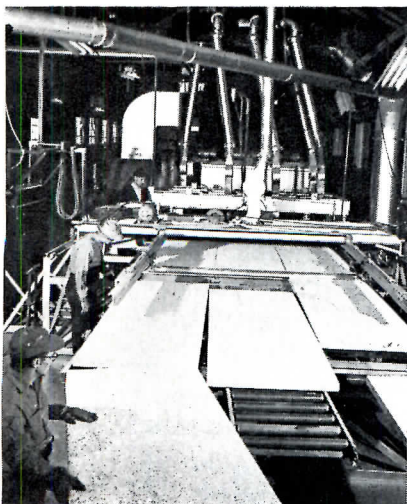

Left: a continuous fabricating process used for *Tectum* panels. Below: typical roof installation



DEVELOPMENTS IN ROOFING MATERIALS

tivity, and may be used with its natural finish or painted. *The Tectum Corporation, Newark, Ohio.*

• The Celotex Corporation announces the addition of *Celotex Channel-Seal Roof Insulation* to its line of rigid insulation board products. Channel-Seal is made from cane fibreboard core stock and coated on all sides and edges with a special asphalt. A bevel on all four bottom edges provides an interlocking series of channels when the roof insulation boards are applied. The channels permit equalizing of air pressure between roof deck and built-up roof to reduce the incidence of blisters caused by local pressure build-up during hot weather. It is said the products have unusually high structural strength and resistance to compression; the fibreboard compresses 1 per cent of its thickness under a load of 700 lbs per sq ft. *The Celotex Corp., 101 Park Avenue, New York 17, N. Y.*

• Follansbee Steel Corporation has developed a technique to install continuous flashing of terne metal on chimneys, avoiding stepdowns and eliminating most of the seams. After the roofing pans have been turned up to form base flashing around the chimney, and corners closed off with corner patches, the roofer uses a 1/4-in. grinding wheel in an electric drill to cut a 1/2-in. groove 4 1/4 in. above the roof line (Fig. 1). Cap flashing is fashioned to go around the chimney and cut and bent to go into the groove (Fig. 2). It is then wedged into place by masonry nails driven into the groove (Fig. 3). Finished flashing is caulked with a suitable compound (Fig. 4). This procedure is claimed to provide a secure and weatherproof flashing. *Follansbee Steel Corp., Gateway Center, Pittsburgh 30, Pa.*

(Continued on page 186)

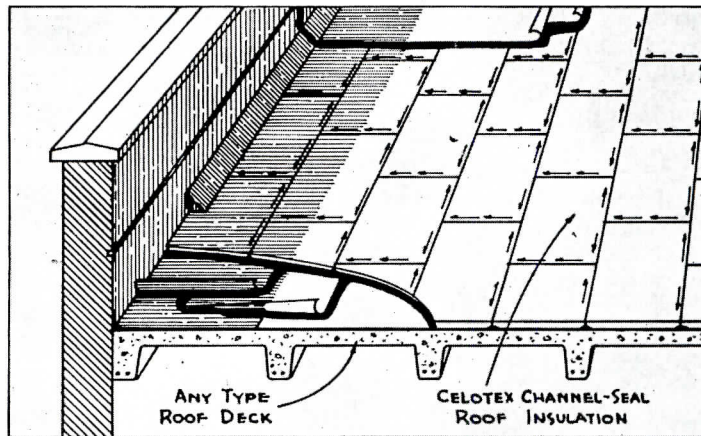

Above: new roof insulation board features beveled edges (detail right) to equalize air pressure, reduce chance of roofing blisters

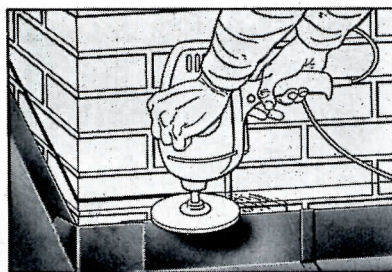
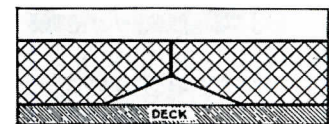

1

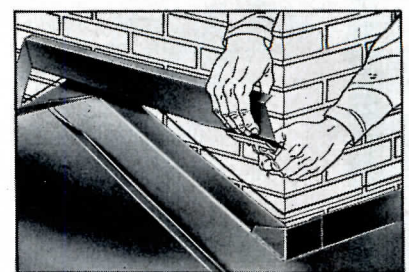

2

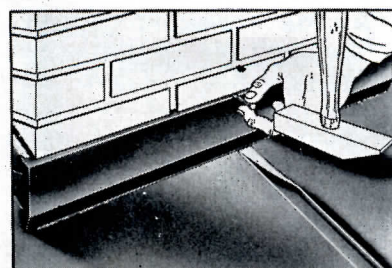

3

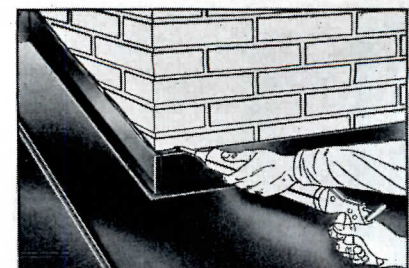

4

Above: recent chimney flashing technique uses a groove in chimney (Fig. 1) to hold bent flashing edges (Fig. 2) wedged in by nails (Fig. 3). Caulking is used to finish (Fig. 4)

**TENNIS COURT
CONSTRUCTION GUIDE**

Pages from booklet on Laykold and Grasstex tennis courts

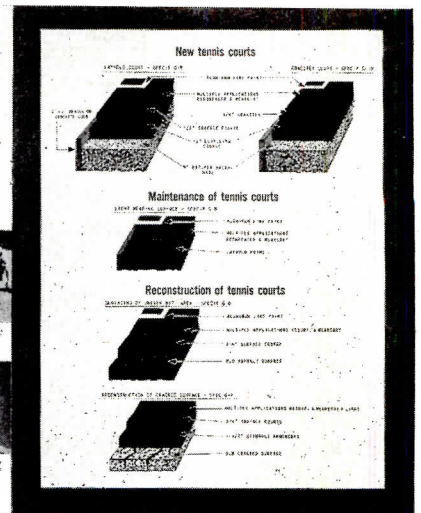
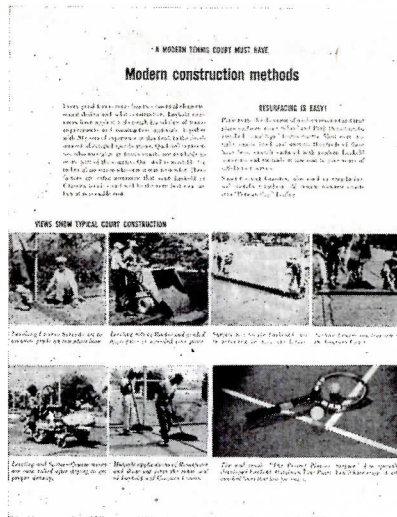

Laykold Tennis Courts, a 12-page, four-color booklet prepared for use by engineers and architects, contains detailed specifications, color photographs of typical installations and information concerning basic types and styles of Laykold and Grasstex courts. The new booklet includes sections on cost, maintenance, resurfacing and player acceptance. Booklet is available from *American Bitumuls & Asphalt Co., 200 Bush St., San Francisco, Calif.*

TELEVISION ANTENNA SYSTEM

Jerrold Catalog No. 601. Booklet describes the manufacturer's "Constant Level" master antenna system. Detailed data, including two charts, points out how this system can be utilized for low cost television reception in hotels, motels, institutions, apartment buildings and department stores. Pictures and text illustrate additional equipment. 4 pp., illus. *Jerrold Electronic Corp., 26th & Dickinson Sts., Philadelphia 46, Pa.*

*** OIL AND GAS BURNERS**

Petro Burners, Form 3048. New catalog of commercial-industrial automatic heating and power equipment includes schematic drawings, layouts of typical installations, and photographs of burners and installations. Specifications and detailed data on exclusive features of oil, gas, and combination oil-gasburners are given. 20 pp., illus. *Petro, 3170 W. 106 St., Cleveland 11, Ohio.*

** Other product information in Sweet's Architectural file, 1953*

NEW FURNITURE

The Dunbar Book of Modern Furniture. This booklet, bound in hard cover, contains 56 pages of text and illustrations, many in color. It consists of a commentary by the Dunbar furniture designer, Edward Wormley, on modern design, including examples by Bruer, Alto, and Eames, and a collection of Dunbar furniture ranging from occasional tables and chairs to complete bedroom sets, all from the Dunbar Centennial series. The booklet also illustrates the steps in furniture construction. Price, \$1.00. 56 pp., illus. *Dunbar Furniture Corporation of Indiana, Berne, Indiana.*

*** STEEL ROLLING DOORS**

Cookson Rolling Doors, Bulletin No. 301. Illustrating the manufacturer's complete 1954 line of steel rolling service doors, "Servire" fire doors, grilles, aluminum rolling counter doors, and specialty doors, catalog features a series of charts designed to simplify selection of proper gauge and type of slats, guide type, power units and other components. Blueprints of 12 basic door types show all necessary architectural dimensions. Underwriters' Laboratory Label requirements are fully outlined. Complete architectural specifications are included. Numerous photographic illustrations show typical standard installations, as well as specially engineered doors with special sliding or hinged mullions, and doors constructed to conform to unusual floor angles. 12 pp. illus. *Cookson Co., 1525 Cortland Ave., San Francisco 10, Calif.*

WALLPAPER MURALS

How to Beautify Your Home With a Wallpaper Mural. Booklet gives suggestions for use of scenic wallpaper murals, pointing out their application in rooms furnished in various period styles. Contains 11 room settings and a complete selection of 16 scenics in full color, 22 room settings in black and white and a section on how to hang a wallpaper mural. Before-and-after illustrations show how murals can help disguise wall protrusions, broken wall spaces, narrow hallways and ceilings that are too low. Specifications are also included in the book. \$1.00 per copy. 35 pp., illus. *James Seeman Studio, 134-12 Atlantic Ave., Richmond Hill 19, N. Y.*

*** KITCHEN PLANNING**

Kitchens That Sing. Booklet contains new ideas and arrangements for kitchens, including plans to combine kitchens and laundries efficiently, employing the Manufacturer's basic "Kitchen Maid" units. Two pages of suggested color combinations are included. 16 pp., illus., *Kitchen Maid Corporation, Andrews, Indiana.*

WATER HEATER

The Bryan Copper Tube Indirect Water Heater. Brochure has notes on basic applications, table of specifications and dimensions, drawings and a cutaway section. 5 pp., illus. *Bryan Steam Corp., Peru, Ind.*

(Continued on page 218)

Another
Adlake
 Aluminum
 Window
 Installation

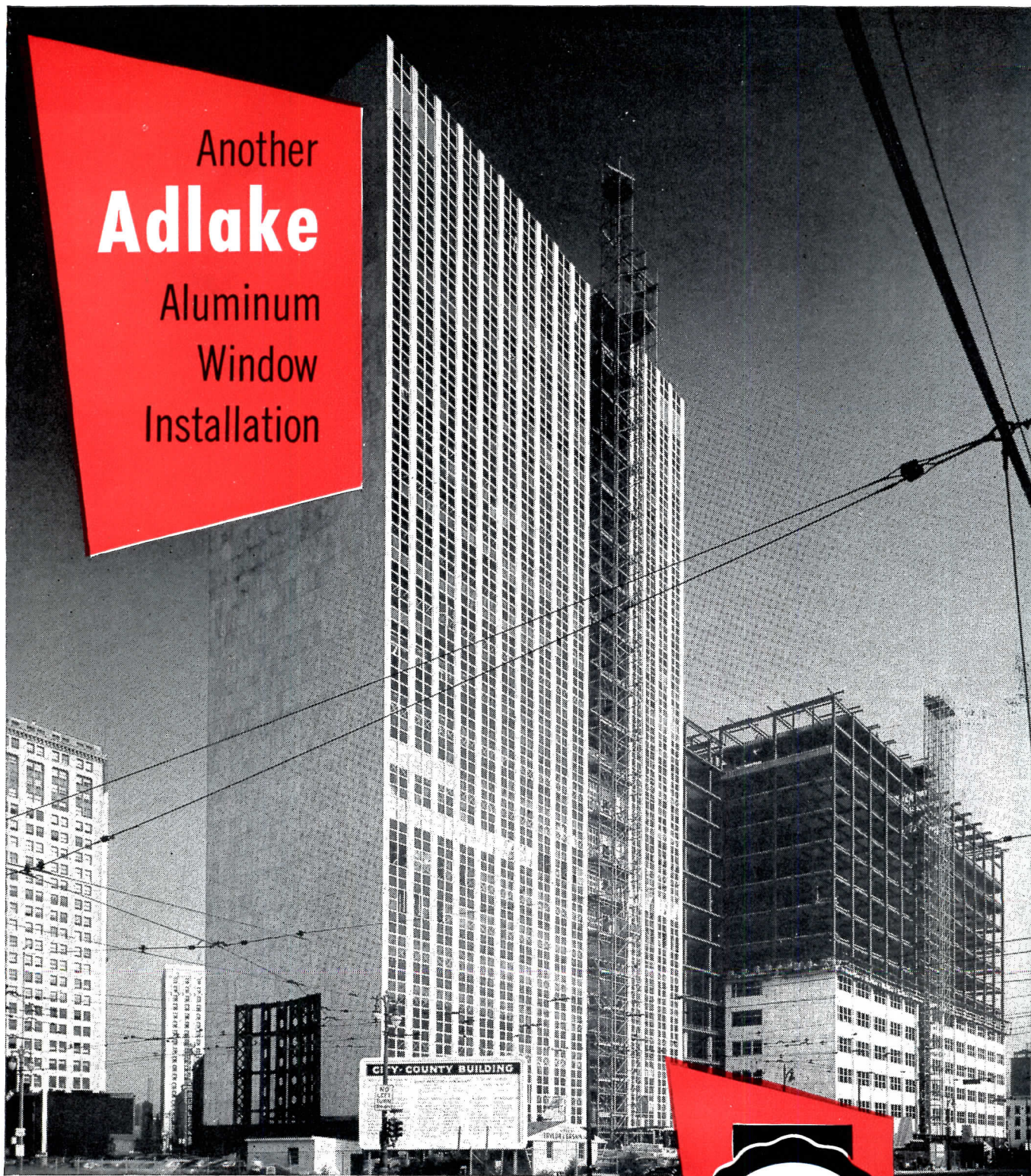

City County Building, Detroit, Michigan—Courts Unit (left) complete and Office Unit (right) under construction. Harley, Ellington & Day, Architects—Bryant & Detwiler, General Contractors.

- Minimum air infiltration
- Finger-tip control
- No painting or maintenance
- No warp, rot, rattle, stick or swell
- Wool woven-pile weather stripping and exclusive patented serrated guides

The Adams & Westlake Company

Established 1857 • ELKHART, INDIANA • Chicago • New York

Also Manufacturers of ADLAKE Mercury Relays and ADLAKE Equipment for the Transportation Industry

Adlake
 PROVEN
 QUALITY
 WINDOW

This window meets or exceeds all quality industry specifications for aluminum windows.

THE
 Adams & Westlake
 COMPANY
 Elkhart, Indiana

97th
 year

of serving the transportation
 and building industries

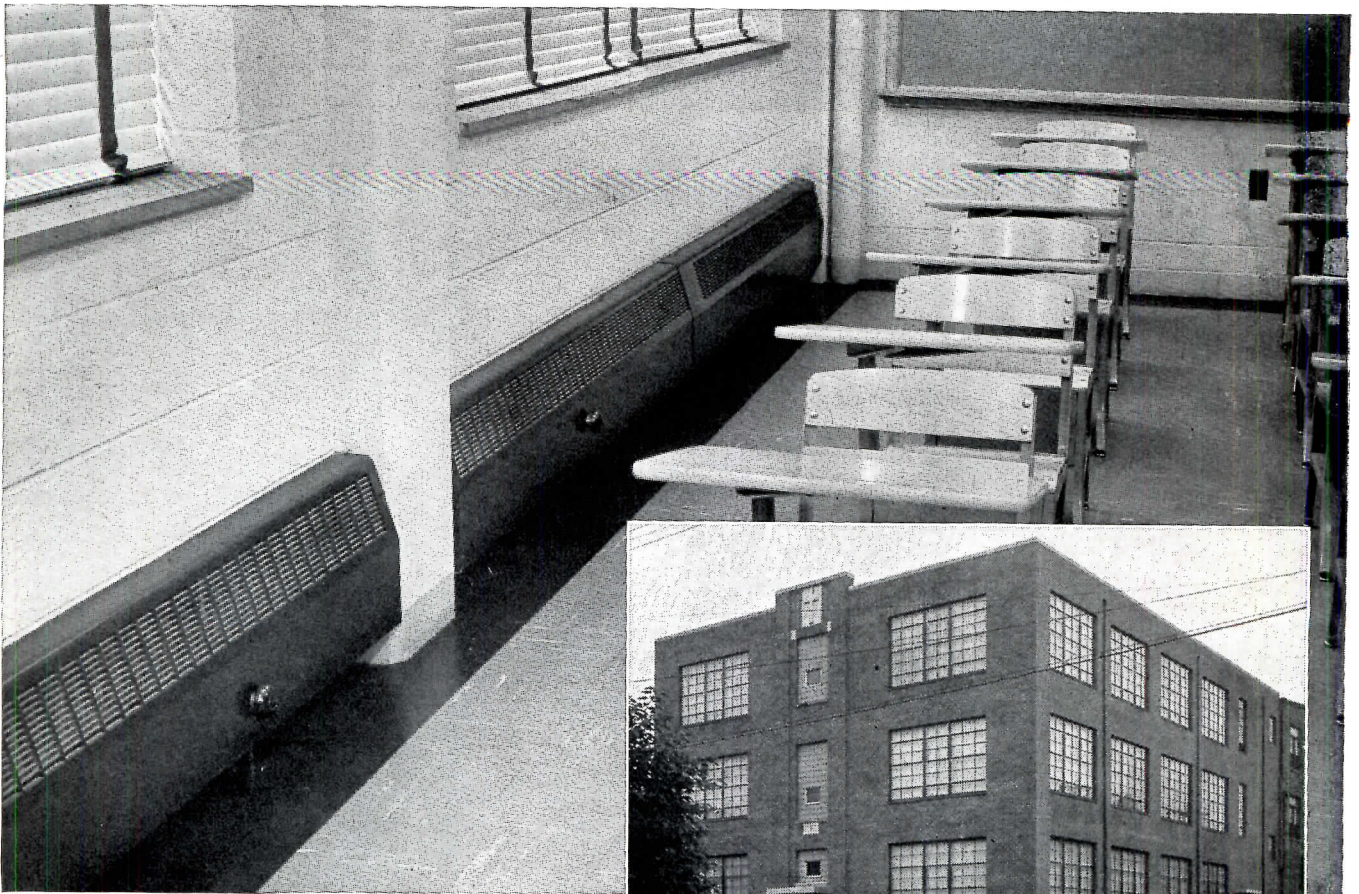

Classroom view, Our Lady of Mt. Carmel School. Tru-Perimeter Heating with Webster Walvector. Sleeves in columns between windows simplify piping without loss of structural strength.

(At right) Our Lady of Mt. Carmel School, Camden, N. J. Floor space, 15,311 sq. ft. Construction cost (not including land, financial and legal expenses) \$200,000. Heating cost, \$14,580. Architects: Gleeson & Mulrooney, Philadelphia. Consulting Engineer: William G. Flurer, Upper Darby, Pa. Heating Contractor: Fred W. Schorpp, Inc., Camden.



11-Room School — \$200,000

Gleeson & Mulrooney, Philadelphia school architects, designed this three-story school building, completed in 1953 at a cost of \$13.10 per square foot. The bright, appealing classrooms accommodate 650 pupils. High windows assure ample light and air.

Economy in first cost was aided by the simplified exterior and absence of unnecessary frills. Nevertheless, the building has such features as slate sills, vermin-proof walls, ventilated clothes closets and well lighted corridors. And the complete Webster Tru-Perimeter Heating System with Webster Moderator Control required less than 7½ per cent of the construction cost.

Webster Walvector spreads the heat evenly along the perimeter of the building, blankets the large window areas, takes no usable floor space. Low pressure steam is under Webster EH-10 Moderator Control, which varies heating automatically with changes in outdoor temperature . . . provides manually for quick heating of rooms when classes arrive,

reduction of heat when they leave. Steam circulation is facilitated with Webster Traps, Valves and Webster Double Service Valves. The rugged, single-unit Webster Moderator Control involves minimum maintenance cost — no blowers or fans, no buried or inaccessible piping.

For money saving on school heating, look into Tru-Perimeter Heating with Webster Walvector and Webster Moderator Control. Call the Webster Representative, or write us.

Address Dept. AR-1

WARREN WEBSTER & COMPANY
Camden 5, N. J., Representatives in Principal U. S. Cities
In Canada, Darling Brothers, Limited, Montreal

Webster
WALVECTOR
REG. U. S. PAT. OFF.
For Steam or Hot Water Heating

SIMPLIFIED WALL FRAMING METHODS—3

Presented through the cooperation of the N.A.H.B. Research Institute

A Planned Order of Assembly Reduces Construction Time

(Continued)

The following Time-Saver Standards pages continue the extracts, begun in the December issue, from "Trade Secrets Report No. 1" prepared for the National Association of Home Builders Research Institute under the direction of Leonard G. Haeger, with Lee Frankl, Consultant. The methods seek to reduce wall framing costs by the use of standard material sizes, pre-cutting, pre-assembly and production line erection techniques.

Planning

Production line methods require complete and careful planning. Management's decisions, as given to the building trades, should be fully detailed drawings and instructions to eliminate variations in procedure and/or construction by labor, as well as the many changes often made in pilot house design and construction.

An hour of detail drafting may save days of on the site labor. Completely detailed plans are necessary if management is to plan the purchase and scheduling of materials, and schedule labor so as to minimize interference of trades on the job. An obvious but often overlooked tool in planning is the grid sheet. The grid enables the draftsman to study and check dimensions easily so that standard sized materials may be specified, eliminating much unnecessary cutting and fitting. Details should be drawn in large scale. Isometrics are good, they are easy to read. Cutaways often are best to show details.

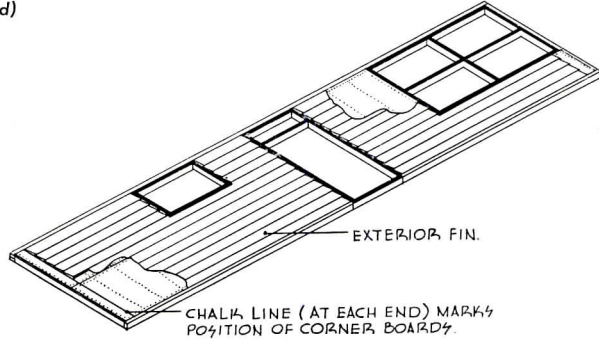

Place exterior finish (sheet material, siding, shakes, etc.). Where corners are used, mark their widths on sheathing, and nail finish material to this line. Apply corners after walls are tipped up and nailed in place.

Where shingles are used it may be easier to leave end shingles off on each course. The end shingles are placed after tip-up is complete and all walls are nailed in place

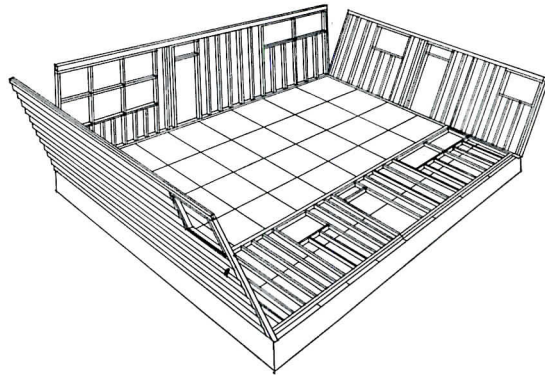

Short end walls are placed first and tipped. They are supported by 2 by 4s (not shown). Rear wall is tipped into place, leveled, nailed to floor and braced. Front wall is likewise tipped up, plumbed, nailed and braced. Short walls are then plumbed, spiked to connecting walls and floor. Four men can handle walls up to 32 ft; six men are needed for walls up to 50 ft. A post and pulley rig makes it possible for two men to handle any size wall

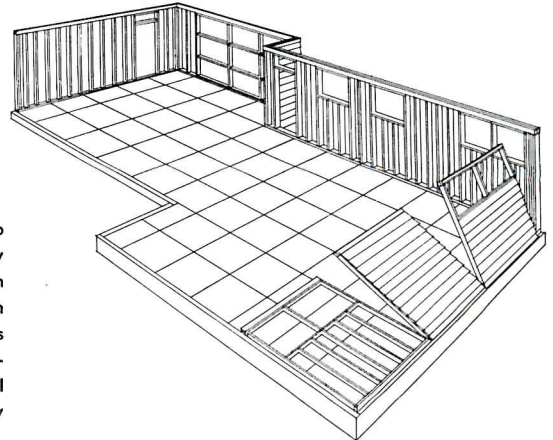

Tip-up starts at any corner for panel section house. Two panels form a corner. One temporary brace for every second panel is ample. Two-man teams can work from each side of starting corner setting small panels. Spikes through floor plates should not be driven home until all panels are placed, then driven all the way. Use 1 by 6 in. diagonally to hold walls in square. Then plumb and brace all walls to inside floor and/or outside walls, whichever may be more convenient

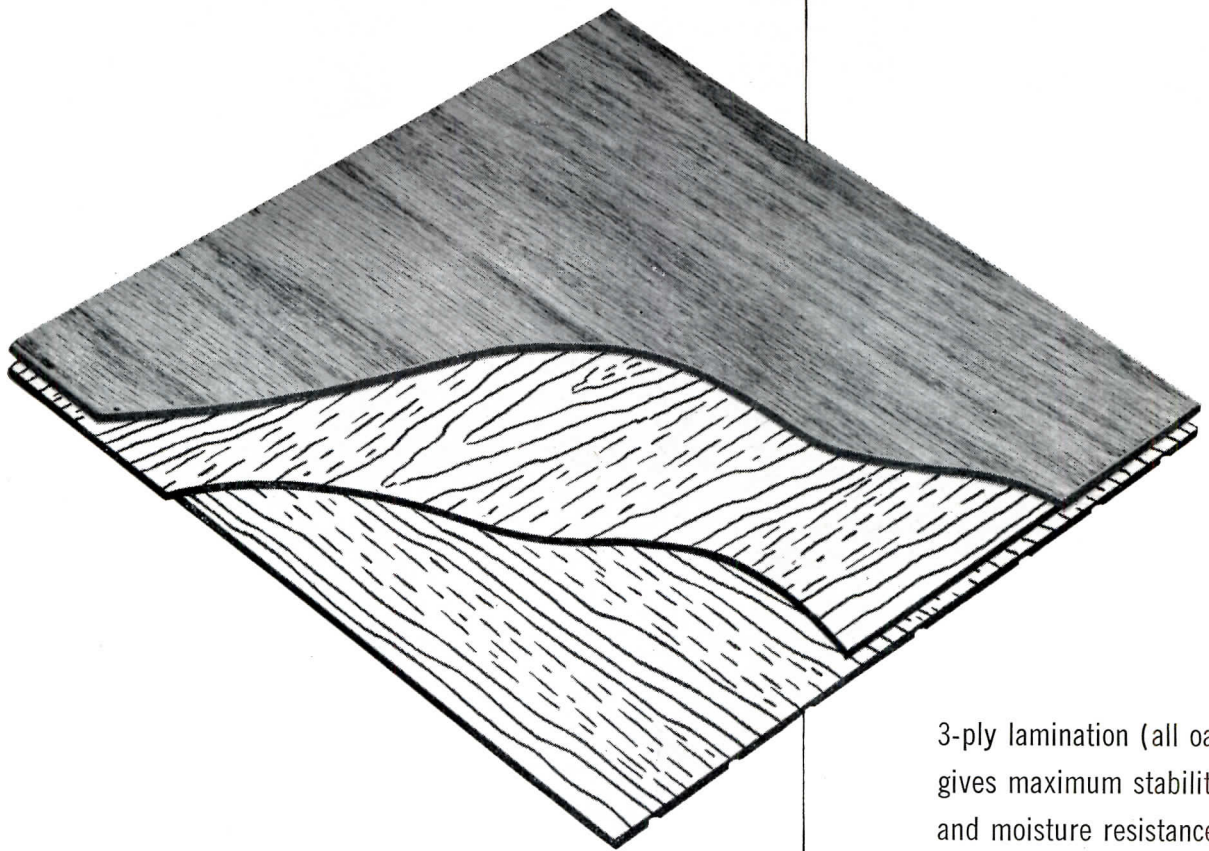

3-ply lamination (all oak)
gives maximum stability
and moisture resistance

NEW OAK FLOORING FOR USE OVER CONCRETE

Bruce Laminated Oak Block

Designed for modern construction

- Lay in mastic directly over concrete
- No expansion joints or spaces needed
- Selected oak for beauty and durability
- Laminated under heat and pressure
- Toxik-treated to resist termite and beetle attack
- No membrane waterproofing required except where dampness is suspected
- Factory-finished for long wear, easy care
- Parquet pattern for contemporary style
- 9x9 in. blocks—½-in. thick
- One grade only—all faces practically clear

LOOK IN SWEET'S—WRITE FOR LITERATURE

E. L. BRUCE CO., MEMPHIS 1, TENN.

World's largest maker of hardwood floors

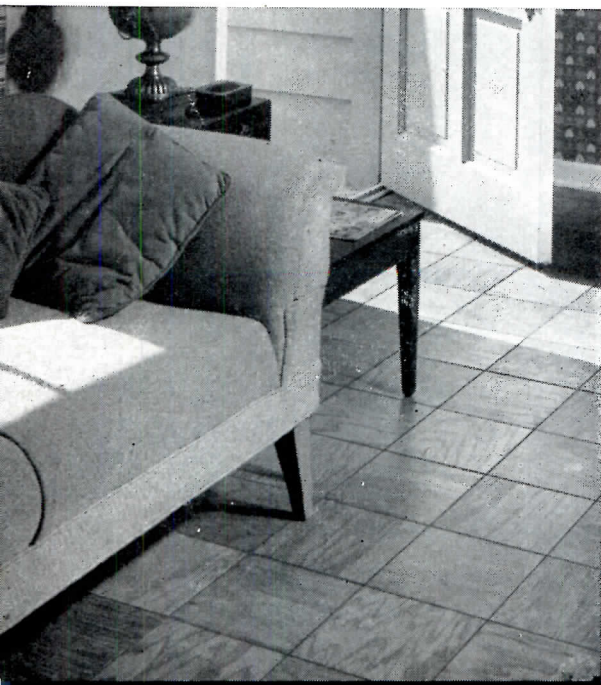

SIMPLIFIED WALL FRAMING METHODS—4

Presented through the cooperation of the N.A.H.B. Research Institute

Fastening Methods

The illustrations of common nailing practices shown below have been taken from "Techniques of House Nailing," a publication of the Housing and Home Finance Agency (HHFA)

Door Openings

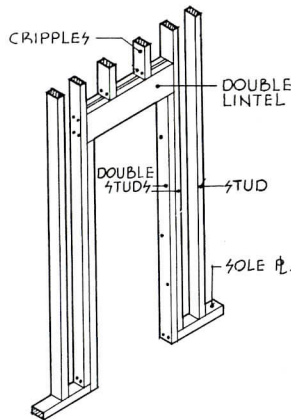

Cripples toenailed to each part of lintel with one 10d nail. Studs nailed to ends of each part of lintel with two 10d nails; double studs nailed together with 10d nails spaced 16 in. apart and staggered as shown. Studs alongside opening nailed into end of sole plate with two 10d nails

Window Openings

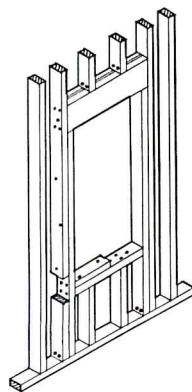

Cripples toenailed to each part of lintel with one 10d nail. Studs nailed to ends of each part of lintel with two 10d nails; double studs nailed together with 10d nails, spaced 16 in. apart, staggered as shown, and toenailed to sole plate with four 10d nails, two from each side. Lower part of sill member nailed to end of each stud below it with two 10d nails. Upper part of sill member nailed to lower with 10d nails, spaced 8 in., and staggered as shown. Studs alongside opening nailed to ends of each part of sill member with two 10d nails

Nailing Symbols

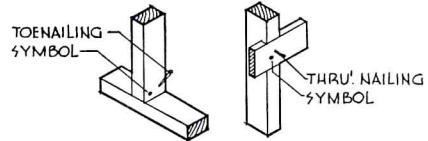

Open circles can represent toenailing in drawings, for extra clarity; closed circles, direct or through nailing

Top Plate

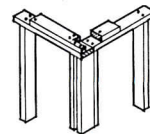

Lower part of plate nailed to each stud and corner post with two 16d nails, two near the ends of each piece; others staggered 16 in. apart

Corner Post

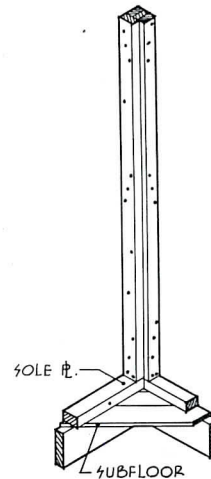

Studs nailed together with 10d nails staggered 12 in., and to filler block with one nail in each block. Studs are nailed to each filler block with three 10d nails. Corner post toenailed to sole plate with two 8d nails on each face

Diagonal Wall Sheathing

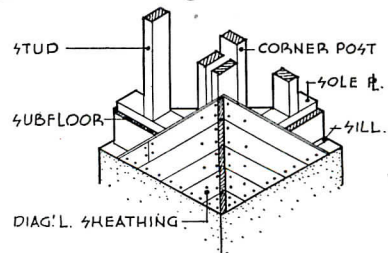

Use 8d nails for boards 8 in. and less in width. Use two nails at each end of board; two nails through each board into studs and three nails through each board into corner post assembly. For wider boards, an additional nail is used at each of these points.

Joints in adjacent lengths of sheathing boards should be separated by at least two stud spaces. If boards are tongued and grooved, end joints need not be made over studs



91% are **p-k** equipped*

* **EAST SIDE, WEST SIDE, all around the town . . .** 91% of the buildings that make up the fabulous New York skyline are **p-k** equipped. This preference for **p-k** heat exchange equipment — including instantaneous hot water heaters, storage water heaters, pre-heaters, condensate coolers, converters, freon coolers — is understandable because **p-k** fully guarantees its equipment, backs it with 73 years of heat exchange experience.

Contact **p-k** when your plans get under way.



the **Patterson-Kelley Co., inc.**

1910 Burson Street, East Stroudsburg, Penn.

Ⓟ 1907

101 Park Avenue, New York 17 • Railway Exchange Building, Chicago 4 • 1700 Walnut Street, Philadelphia 3 • 96-A Huntington Avenue, Boston 16 • and other principal cities.

SIMPLIFIED WALL FRAMING METHODS—5

Presented through the cooperation of the N.A.H.B. Research Institute

Plywood Sheathing

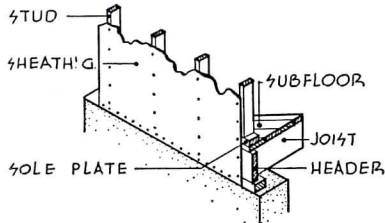

Sheathing less than 1/2 in. thick is nailed with 6d nails spaced 5 in. apart along edges; 10 in. apart on intermediate framing members. Plywood 1/2 in., or more, thick and fiberboard wall sheathings are nailed with 8d nails and require the same spacing. Nails for fiberboards should be rust resistant. Panels are placed lengthwise across

Bevel Siding and Drop Siding

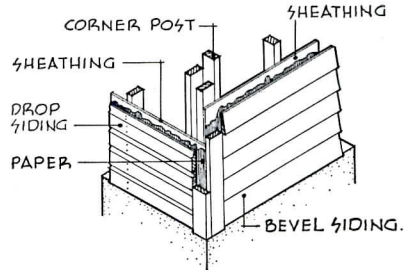

Are face-nailed to each stud; bevel siding with two 8d rust resistant casing nails driven through overlap of siding, then sheathing into each stud; drop siding with two 9d casing nails, one near top of flat surface and the other at bottom. When siding is applied in jig, corner boards are placed and nailed after tip-up. A poor practice is to allow siding to start and end at corners, then covered with corner boards. The spaces between corner boards and siding are likely to rot when water settles in these spaces

Special Fastening Device Applications Are Shown Below

Metal Grip Applications

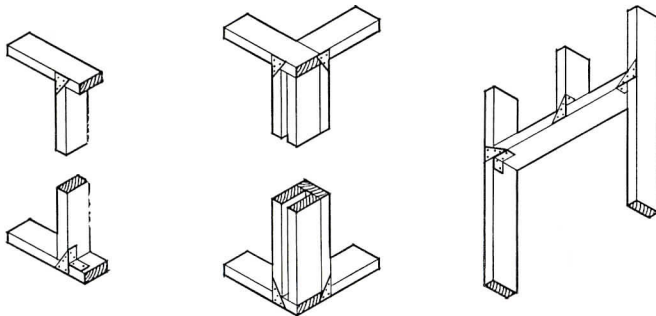

Screw type nails may obviously replace common and casing nails in all applications shown in this report. Although more costly, the smaller screw type nail and probably fewer nails and less labor will reduce the difference substantially

Hurricane Brace Applications

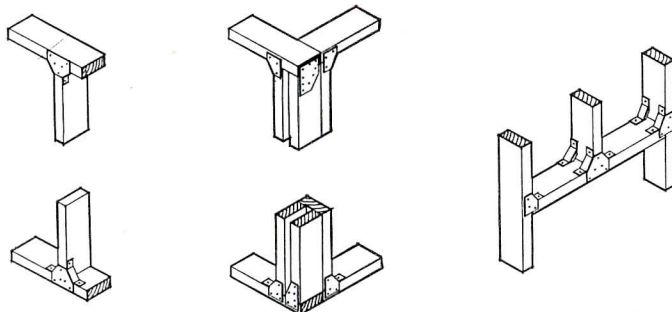

Screw Type Nail		Common Nail	
	Suggested Length	Penny Size	Length
	1 1/2"	6d	2"
	2" or 2 1/2"	8d	2 1/2"
	2 1/2"	10d	3"
	3"	16d	3 1/2"
	3" or 3 1/2"	20d	4"

26,880

Square Feet

of Door Opening in 12 Leaves

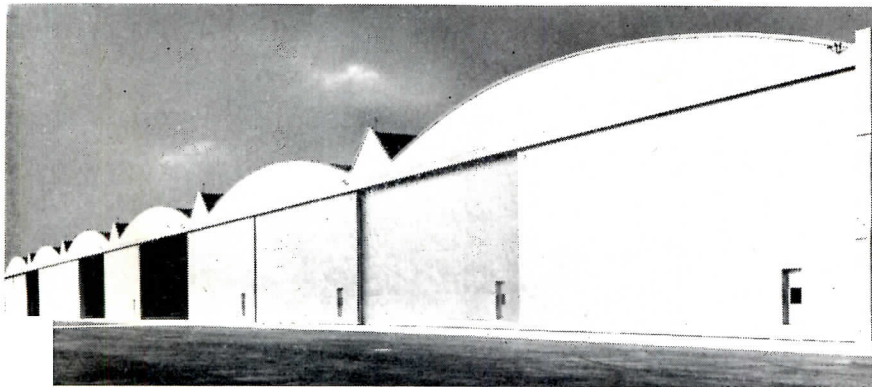

... Another Byrne "First" in Hangar Door Construction

Over $\frac{2}{3}$ of an acre in hangar door opening. That's what the Port of New York Authority ordered for a recently completed aircraft hangar space at New York International Airport. Here was a new problem—to build extremely wide, sliding and individually motorized hangar doors!

The solution can be noted in the picture above. Twelve steel leaves 70 feet wide and 32 feet high. Each leaf individually motorized and providing each hangar with a 140 foot opening. Finished leaves weigh over 20 tons, yet each opens at a rate of 60 feet per minute.

All hangar door openings present problems involving specialized technical skill. To assure a door that is structurally sound . . . easy and economical in operation . . . fast acting . . . dependable and weather tight . . . a competent and experienced manufacturer is the first requisite. Byrne engineers are qualified by 25 years of progressive development with doors of all kinds.

For your unusual closure problems in industrial and hangar doors of all types—turnover doors, vertical lift doors, crane entrance doors, canopy doors, sliding doors—Byrne offers unequalled solutions.

FOR INFORMATION regarding Byrne doors and facilities consult Sweet's Catalog or write direct for our brochure.



BYRNE doors, inc.

Dept. r-2

1421 East 8 Mile Road, Ferndale, Detroit 20, Mich.

101 Park Ave., New York 17, N.Y.

Cafritz Bldg., Washington 6, D.C.

AH PRODUCTS

(Continued from page 177)

NEW PORTABLE WIDE SCREEN

For use with wide screen motion picture projection in the 16mm field, a portable Radiant *Curvex* Screen will be available in sizes from five ft to 20 ft wide. The screen is made with a highly reflective silver fabric, two and one half times as wide as it is high. The tightly woven, special treated fabric is on an aluminum framework which curves the screen to help increase the illusion of depth and to give better reflected light distribution throughout the area of observation. When the screen is not in use, the fabric may be rolled and the light weight frame folded for quick storage into a portable metal case. Radiant Mfg. Corp., 2627 W. Roosevelt, Chicago, Ill.

PLASTIC WINDOWS

The new Inglewood Y.M.C.A. Building, which was dedicated November 15th, has *Plexolite* glass fiber reinforced plastic panels for the gymnasium windows. These shatterproof translucent panels can be used in many of same places as wire guards and wired-glass glazing, and provide a source of diffused light that does away completely with blinding sun-glare. One entire wall of the gymnasium room has been glazed



Shatterproof windows used in gym

with these panels. Basketball backstops and volleyball courts are within a few feet of this wall, and the ball frequently strikes the windows while in play, only to rebound harmlessly. The windows are also found in the locker-rooms where they have been fitted into the basic construction of the building in such a way as to eliminate framing entirely. *Plexolite Sales Company, 4223 W. Jefferson Blvd., Los Angeles, Calif.*

(Continued on page 190)

Pittsburgh Doorways come in a "package"— for quick, easy, cost-cutting installation



Architects: Corning and Moore, Washington, D.C.

• When a Pittsburgh Doorway reaches the job, all that's necessary is to unpack the frame, bolt it into the building opening and hang the Herculite Doors. Factory-assembled to precision standards, there is no laborious and expensive fitting or fabricating required at the site. Moreover, the frame's handsome appearance and rugged construction assure doorways that are both trouble-free and distinctive. For the frames are fabricated of heavy extruded aluminum, reinforced with steel channels and tie rods.

In choosing a doorway, it's well to remember that the *total-installed* cost—not the list price—is the real consideration. Pittsburgh Doorways save on installation time and labor; their quality is unsurpassed. So they offer more . . . actually cost less!

Why not let us send you complete information? Or, if you are now faced with a doorway problem, let our specialists give you their recommendations. There is no obligation on your part. Write to Pittsburgh Plate Glass Company, Room 4119, 632 Fort Duquesne Blvd., Pittsburgh 22, Pa.

THIS DIAGRAM explains the operation of the Pittcomatic Hinge. The power unit supplies hydraulic power to the hinge under the door through $\frac{3}{8}$ " copper lines. A 10-volt circuit in the handle passes through the control box and activates the power unit. Oil lines are 3000-lb. test. The action of the door is regulated in all respects by the adjustments provided in the control box and the hinge. No power can build up, so it's a safe door.

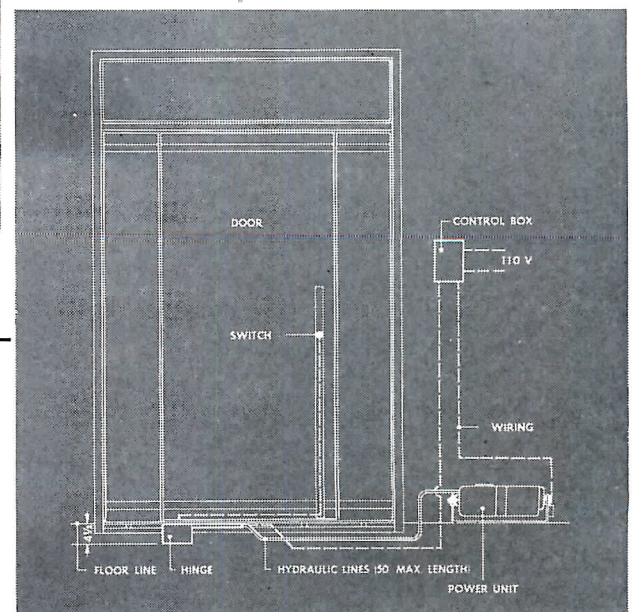

Pittsburgh DOORWAYS

PAINTS • GLASS • CHEMICALS • BRUSHES • PLASTICS • FIBER GLASS



PITTSBURGH PLATE GLASS COMPANY

IN CANADA: CANADIAN PITTSBURGH INDUSTRIES LIMITED

WASHINGTON

(Continued from page 38)

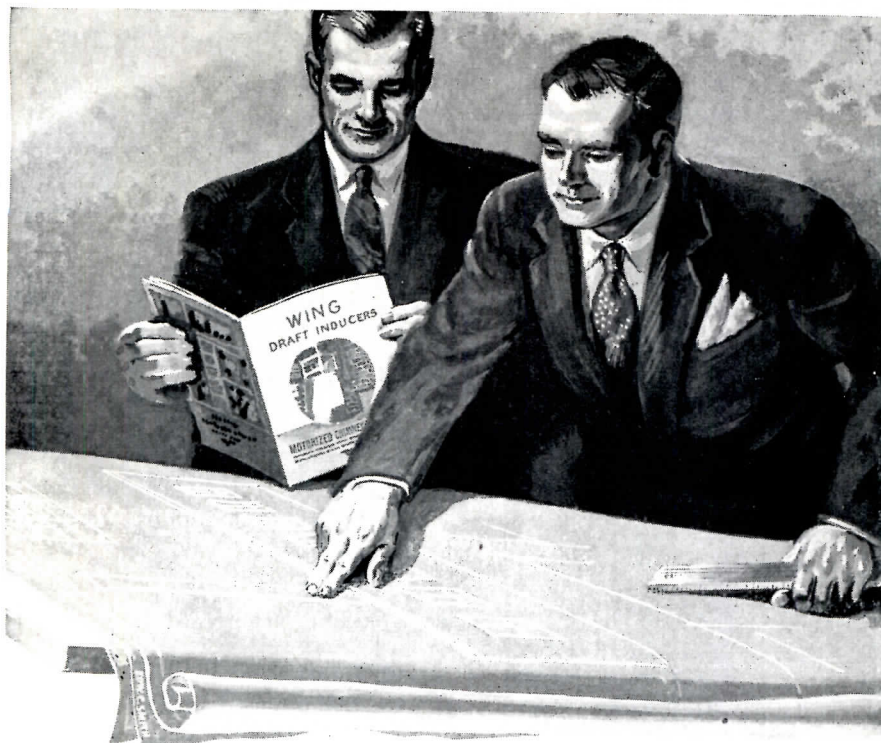

"...Let's cut this stack off here and put a Wing Draft Inducer on the boiler... We'll save the cost of the chimney, have better draft and a better looking building."

If you are building or rebuilding or increasing the size of your boiler plant, a costly, tall chimney can add considerably to the expense. And a well planned architectural design can be ruined with an unsightly, towering stack.

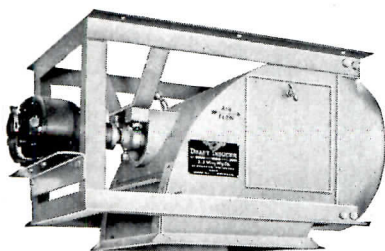

WING DRAFT INDUCERS

eliminate this problem, providing positive, adequate, uniform draft regardless of surrounding conditions, or variable weather. They cut operating costs too, by giving higher CO₂'s. Smoking is reduced or eliminated. Higher boiler capacity is possible.

Write for Bulletin I-52



L. J. Wing Mfg. Co.

151 Vreeland Mills Road
Linden, New Jersey

Factories: Linden, N. J. and Montreal, Can.



Undersecretary Walter Williams told the National Association of Real Estate Boards convention in Los Angeles that there is no "mature economy" in construction or real estate.

Mr. Williams said the recent rates of construction in relation to the entire economy have not exceeded the relative proportion of earlier years.

It appears, in fact, that the 1953 record in construction will be attained with the amount of construction relative to the total economic activity being slightly less than in other years. In 1939 it was 13.1 percent of gross national product; in 1953 it probably will be approximately 12.7 percent.

The more usual types of public construction have lagged seriously behind conservatively estimated needs, Mr. Williams added.

AIRPORT FUNDS FROZEN — NO NEW COMMITMENTS

Civil Aeronautics Administration ended fiscal 1953 (last July 1) with \$2.5 million unobligated for Federal aid airport construction. About \$1.5 million will be consumed by administration, leaving \$1 million for airport building—funds now "frozen" by the agency.

Officials say if and when this \$1 million is divided among states under the CAA formula, it will mean but a small drop in any one state bucket: "very little or nothing to local sponsors," is the way they put it.

CAA is working on what it calls "the expeditious completion" of projects now underway, but is making no new commitments.

NEW DMS SETUP PLANNED TO CUT DOWN PAPERWORK

The Defense Materials System is being overhauled.

Sometime this month, officials expected to have new procedures in effect which would remove up to 85 per cent of the paperwork formerly burdening suppliers to defense and Atomic Energy Commission contractors.

The new DMS plan scrapped quar-
(Continued on page 226)

THE ARCHITECT...

... AND THE PROBLEM OF FINANCING NEW BUILDINGS FOR NON-PROFIT INSTITUTIONS

NON-PROFIT INSTITUTIONS all over America face the difficult problem of mobilizing private funds to finance the construction of urgently needed schools, hospitals and religious buildings.

Right now this is a multi-billion-dollar problem. The backlog of private institutional building needs bequeathed to us by the depression of the Thirties, by World War II and by postwar materials restrictions is still enormous. On top of that our population is growing at the unprecedented rate of 2,000,000 persons annually.

The architect can help non-profit institutions* solve this problem of raising funds on a sound and appropriate basis.

We know of many instances in which architectural plans were actually completed for an institutional building but, unfortunately, work could not progress because funds were not available.

In some such instances the institution would have benefited greatly had the architect been familiar with the services of a non-profit institutional financing counsellor, and had the architect been able to explain the operations of such an organization to his client.

You can obtain full information on how such a firm has helped to mobilize private funds for many non-profit institutions by writing on the letterhead of your firm to *Mr. James H. Fraser, Lawson Associates, Inc., Rockville Centre, N. Y.*

** These are principally non-profit general hospitals, private and parochial elementary and secondary schools, colleges and religious institutions.*

Lawson  *Associates*
INCORPORATED
ROCKVILLE CENTRE, NEW YORK

Kinnear Steel RōL-TOP Doors



Extra "Doorability" of Heavily Galvanized Sections*

Will not sag, warp, rot or split
Built to fit openings of various sizes
Easy space-saving upward action
Opens completely out of the way

Lasting resistance to fire, wind, weather
Heavy-duty torsion spring counterbalance
Provision for any number of glass panels
Easily installed in old or new buildings

WRITE FOR THIS
FREE
RōL-TOP BULLETIN
TODAY!

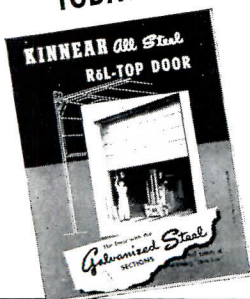

KINNEAR
ROLLING DOORS
Saving Ways in Doorways

In Kinnear Steel RōL-TOP Doors, you get the efficiency of smooth ball-bearing upward action . . . *plus* all-steel strength and durability . . . *plus* provision for glass panels in one or more door sections, as desired.

*To assure extra service life with minimum maintenance, the rugged steel sections are given a heavy coating of pure zinc (1.75 oz. per square foot of flat metal per ASTM standard) by the hot process. Then Kinnear's Paint Bond (a special phosphate immersion process) is added, to make sure paint will adhere *immediately and thoroughly* to the protective zinc coating.

In every detail, Kinnear Steel RōL-TOP Doors feature extra strength and ruggedness, for long, heavy-duty, low-cost performance. Sizes to fit any opening. Manual, chain, or motor operation. WRITE FOR FULL DETAILS.

Kinnear Steel RōL-TOP Doors are designed and built by the same door specialists who *originated* the door with the interlocking steel-slat curtain—famous for more than half a century as the Kinnear Steel Rolling Door.

The KINNEAR Manufacturing Co. Offices and Agents in
All Principal Cities
FACTORIES: 1860-80 Fields Ave., Columbus 16, O.—1742 Yosemite Ave., San Francisco 24, Calif.

THE RECORD REPORTS

WASHINGTON
(Continued from page 224)

terly allotments of steel, copper and aluminum for subcontractors, substituting a simple priority rating. This means much less bookkeeping and less expense; in many instances extra help had to be hired for bookkeeping alone.

Prime contractors benefit too. They continue to receive quarterly allotments for themselves but no longer have to receive subcontractors' allotments as well and pass them on down the line.

Metal producers continue to get quarterly directives on the defense and AEC work. These directives henceforth will include direct allotments to prime contractors and estimates of metals required by the new priority ratings.

ODM SETS UP COMMITTEE TO ADVISE ON MATERIALS

The Office of Defense Mobilization has established an interdepartmental Materials Advisory Committee to advise ODM on policies relating to defense materials, including stockpiling.

The committee will consist of an assistant director for materials (ODM) and one representative from each of these agencies: Interior, Commerce, Defense, General Services Administration, State, Foreign Operations Administration, and Agriculture.

The new group will supervise content, status, rate of progress and completion dates of defense materials programs, changes in emphasis and new programs required to improve supplies.

NECA PREPARES TO RENEW FIGHT ON BID PROCEDURE

Both sides — electrical contractors and general contractors — were prepared to renew their struggle over the question of Federal legislation setting out a new bid procedure standard for certain types of government construction.

The National Electrical Contractors Association has called on 80,000 members of the specialty mechanical contracting industries to renew efforts in support of the proposed Federal construction contract act.

(Continued on page 230)

INVISIBLE RADIANT HEATING

fills every room with sun-like warmth



There's more livable space and your clients are happier with modern heating units which are out of the way and invisible.



plan homes for more *Comfort*
with **THRUSH RADIANT HOT WATER HEAT**

HEAT HOMES BETTER AT LOWER COST

NOW YOU can provide the finest automatic heating comfort in the homes you plan or build, for Thrush Radiant Hot Water Heat is well within the budget of the smallest home. It is one of the most efficient, economical and completely automatic controls for radiant hot water heat offered today.

Fuel is saved because there is never any overheating. There is no chilling or discomfort, because radiant heat is present. Room temperature varies less than one-fifth of one degree. Installation costs are reduced. Also, a plentiful supply of hot water for kitchen, laundry and bath is available the year 'round from the regular heating boiler. Get the facts now!



write for new booklet

Send coupon below for our new, illustrated booklet which tells all about Thrush System. Also see our catalog in Sweet's.

The Thrush equipment shown at right maintains room temperature without noticeable variation throughout the heating season.

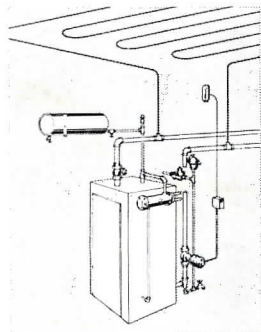

mail today

H. A. THRUSH & COMPANY
Department J-1, Peru, Indiana

Please send, without obligation, a copy of your new, illustrated booklet describing Thrush Radiant Hot Water Heat.

NAME _____

ADDRESS _____

CITY _____

STATE _____



**ONLY AMPLEX
SWIVELITES
GIVE YOU
EVERYTHING**

Compare accent lighting lines and you'll find that Amplex Swivelites have *everything* that assures maximum efficiency and service economy. Just check these features: adapt-a-unit principle that gives you an entirely different fixture in minutes . . . superior swivel with positive, finger-touch positioning . . . airflow ventilation that definitely prolongs lamp life . . . unsurpassed styling . . . permanent, lustrous finish. Write for the full Swivelite story.

AMPLEX

AMPLEX CORPORATION, DEPT. D-1, 111 WATER ST., BROOKLYN 1, N. Y.

THE RECORD REPORTS

WASHINGTON

(Continued from page 226)

The Associated General Contractors of America, Inc. can be expected to oppose the legislation vigorously as it did last year. Bills moved through committees in both houses but did not reach a vote in either body.

N.E.C.A. is confident that it is nearer success now than at any time in its long battle to secure a new law on the subject of bidding procedure.

CHURCH GROUP SUPPORTS PUBLIC AID TO HOUSING

The National Council of Churches, with some 35 million members among its 30 denominations, is on record supporting the general principle of assistance by Federal, state and local governments in the solution of the national housing problem. N.C.C. also would resume the Federally-supported housing research program that was denied any funds by the first session of the 83rd Congress.

The position was made known in a report by the executive board of the Division of Christian Life and Work, approved by the Council's General Board at a recent bi-monthly meeting in Washington. (The action came just in time to be given consideration by the President's Advisory Committee on Housing before that body made its final report.)

On the premise that millions of Americans still dwell in indecent and overcrowded housing and in congested slum areas, the Council statement takes the view that the high rate of housing construction must be continued. At the same time, it urges that uninhabitable dwellings which are structurally unsound should be torn down at the earliest practicable moment.

Conservation Given Role

The matter of conservation also entered the Council's arguments when it asserted the objective of more and better housing also requires "the protection or rehabilitation of older housing that is basically sound, both under pressure of enforcement of local, county and state housing and zoning codes, and by the stimulation of voluntary neighborhood cooperation and planning."

(Continued on page 234)



BEFORE

Ugly, old-fashioned, this MIRON Building was an eye-sore!

AFTER

Modern, attractive, MIRON presents an appealing face to the public...transformed by SEAPORCEL background panels and striping in light blue and white stippled matte finish, with border panels and returns slighter darker.



MIRON FURNITURE STORE, Plainfield, N. J.-Architect: Harry Alper, N. Y.

What a difference SEAPORCEL makes!

You can see for yourself that **SEAPORCEL ARCHITECTURAL PORCELAIN** actually performs miracles of transformation! For who would believe that so much could be done for the ugly, old-fashioned **MIRON** building you see above. *AND REMEMBER:* Seaporcel's numerous dies make available an economical selection of "shaped" parts, extruded or reverse, for maximum effectiveness as spandrels, mullions, awning hoods, bulkheads, piers, sign facias, soffits and entire facades.

Obtainable in a variety of complementary colors, these Seaporcel UNLAMINATED parts combine perfectly with SEAPORCLAD* laminated building panels.*

For Some Job...Somewhere...You Can Use SEAPORCEL*

Let Seaporcel's successful applications be your guide to future planning... write for brochure #12

There are a few areas in which Seaporcel Metals, Inc., is not represented. Inquiries from interested agents are invited.

SEE OUR CATALOG IN SWEET'S

Seaporcel

SEAPORCEL METALS, INC.
2800 Borden Avenue
Long Island City 1, New York

SEAPORCEL PACIFIC, INC.
1461 Canal Avenue
Long Beach 13, California

ARCHITECTURAL PORCELAIN

Member: Porcelain Enamel Institute A. F. OF L. METAL FABRICATING & ENAMELING PLANTS

COMPLETE ENGINEERING & ERECTION DEPARTMENTS

*Reg. U.S. Pat. Off.

THE RECORD REPORTS

WASHINGTON (Cont. from p. 230)

While home ownership is highly desirable, it added, private enterprise must endeavor to meet the continuing need for more rental housing within middle-income capacity to pay.

One addition to the report as it was brought from the executive board of the division called upon church leaders to look to their own substandard housing properties with a view to putting the

advice on "conservation" into practice.

Charles Taft of Cincinnati, chairman of the Council's department of church and economic life, presented the report for Board action. In so doing, he remarked that some validity in the "hand-me-down" theory in housing must be recognized, but he complained that the principle of trickle-through doesn't work fast enough.

Research Funds Asked

As for research, the council asks resumption of Federal aid for housing research and experiment aimed at improving technological operations of the building industry and at finding new ways to reduce building costs. This aid, it commented, can contribute substantially to the long-range goal of providing good housing for every American.

Total non-segregation was urged.

AIR BASE ISSUE REVIVED AS SPANISH JOB BEGINS

The issue of construction waste at foreign bases apparently is not dead. Rep. Robert L. F. Sikes (Fla.), returning from a visit to African and European bases, charged the armed services have failed so far to punish officers and civilians responsible for malpractices at the African locations.

Congressional Committees last year issued reports on poor practices uncovered; the military explained the most efficient planning had been impossible in view of speed required for construction.

Defense Department says it will move rather slowly with air base construction in Spain to assist the local economy in adjusting to the huge program. Study of sites, topography, position in relation to existing cities and communications may occupy engineers until sometime next summer. Actual work will be done by Spaniards under American supervision. It may be 1956 or 1957 before the fields are completed, if there is no deterioration in the international situation.

Meanwhile, all questions on submission of contractors' brochures were referred to Capt. D. B. Ventres, Bureau of Yards and Docks. Estimated cost of the projects runs well over \$100 million. Prime contract will be awarded by Navy shortly after first of the year.

ADDENDA

- The total estimated cost of more than 2000 projects now approved in the Hill-Burton Hospital Act program administered by the Public Health Service continued to push on toward the \$2 billion mark; Federal share had passed the half-billion point. As of most recent summary (November): total projects in all phases, 2144; total cost, \$1,721,032,913;

(Continued on page 238)



You're Sure...
when you specify
QUALITY PRODUCTS
by **NATIONAL LOCK**

Series "410" and Series "440"

NATIONAL LOCK set

Two complete lines of smartly-styled locksets, offering a wide choice of finishes... including anodized satin aluminum. Durable construction, easy to install, for every door in the home.

Butts, Hinges, All Kinds of BUILDERS HARDWARE

Builders butts... square and round corners... regular and half surface types. Strap hinges, "T" hinges, hinge hasps, butt hinges. All popular sizes and finishes. Items conveniently packaged.

An Extensive Line of Chrome CABINET HARDWARE

Hinges, catches, pulls, concave knobs in Brass, Steel and Die Cast material. Beautiful dull or bright Brass, Bronze and Chrome finishes. Quiet-operating rubber roller catch. Smartly packaged.

Dead Black, Old Copper, Old Brass FORGED IRON HARDWARE

Reflecting the traditional charm of Early American living. Handles, hinges and knobs for kitchen, den, game room, living room. Ideal for use on both natural and painted surfaces. Order now.

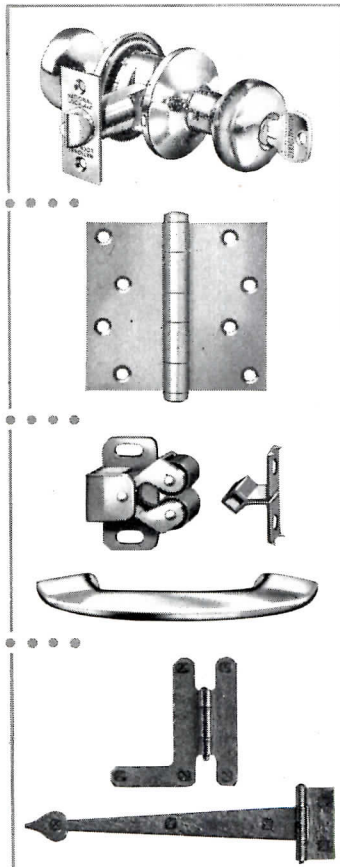

Write us for Descriptive Literature...



Distinctive Hardware — All from] Source
NATIONAL LOCK COMPANY
Rockford, Illinois • Merchant Sales Division

Find your nearest "VIKING" representative here . . . He's ready to help you design a "VIKING" system into your next building.

CRAWFORD and SLATEN CO.

Mr. J. Cousart, Atlanta, Ga.

VIKING AUTOMATIC SPRINKLER CO.

Mr. J. M. Cashman, Boston, Mass.

VIKING AUTOMATIC SPRINKLERS, INC.

Mr. H. B. Kirkman, Buffalo, N. Y.

VIKING AUTOMATIC SPRINKLER CO.

Mr. H. F. Grenning, Mr. C. W. Hauth, Mr. H. Hartel, Chicago, Ill.

VIKING SPRINKLER CO.

Mr. W. H. Bihlman, Cincinnati, Ohio

VIKING SPRINKLER CO.

Mr. O. H. Gellhaus, Cleveland, Ohio

VIKING SPRINKLER CO.

Mr. O. H. Fateley, Indianapolis, Ind.

VIKING SPRINKLER CO.

Mr. P. A. Stevens, Louisville, Ky.

TEXAS AUTOMATIC SPRINKLER CO.

Mr. J. E. Bush, Mr. Rainey Westberry, Dallas, Texas

TEXAS AUTOMATIC SPRINKLER CO.

Mr. J. B. Manning, Houston, Texas

TEXAS AUTOMATIC SPRINKLER CO.

Mr. J. H. Westberry, San Antonio, Texas

TEXAS AUTOMATIC SPRINKLER CO.

Mr. F. E. Westberry, Memphis, Tennessee

TEXAS AUTOMATIC SPRINKLER CO.

Mr. T. J. Kainz, Jackson, Mississippi

TEXAS AUTOMATIC SPRINKLER CO.

Mr. L. E. Edwards, New Orleans, La.

TEXAS AUTOMATIC SPRINKLER CO.

Mr. L. D. McCraw, N. Little Rock, Arkansas

TEXAS AUTOMATIC SPRINKLER CO.

Mr. J. C. Watkins, Oklahoma City, Oklahoma

TEXAS AUTOMATIC SPRINKLER CO.

Mr. D. W. Smith, Tulsa, Oklahoma

VIKING SPRINKLER CO.

Mr. W. I. MacGinnis, Detroit, Mich.

VIKING SPRINKLER CO. OF WESTERN MICH.

Mr. G. C. Hansen, Grand Rapids, Michigan

VIKING SPRINKLER CO.

Mr. G. T. Gregory, High Point, N. C.

VIKING SPRINKLER CO.

Mr. T. D. Comery, Richmond, Va.

C. W. HUTCHINSON, INC.

Mr. C. W. Hutchinson, Huntington, W. Va.

WALTON VIKING CO.

Mr. J. E. Johnson, Kansas City, Kansas

WALTON VIKING CO.

Mr. C. E. Turner, St. Louis, Mo.

WALTON VIKING CO.

Mr. John Carroll, Omaha, Neb.

WALTON VIKING CO.

Mr. B. W. Young, Denver 20, Colorado

CALIFORNIA VIKING SPRINKLER CO.

Mr. R. L. Thorsdale, Jr., Los Angeles, Calif.

CALIFORNIA VIKING SPRINKLER CO.

Mr. R. H. Crawhall, San Francisco, Calif.

VIKING SPRINKLER CO.

Mr. G. B. Higgins, New York, N. Y.

VIKING SPRINKLER CO.

Mr. A. C. Rudin, Hillside, N.J.

VIKING SPRINKLER CO.

Mr. J. H. Keelan, Jr., Philadelphia, Pennsylvania

VIKING SPRINKLER CO.

Mr. T. F. Smith, Washington, D. C.

VIKING AUTOMATIC SPRINKLER CO.

Mr. R. L. Thorsdale, Mr. L. R. Carlson, Seattle, Washington

VIKING AUTOMATIC SPRINKLER CO.

Mr. J. W. Larson, Portland, Oregon

VIKING AUTOMATIC SPRINKLER CO.

Mr. H. McDonald, Vancouver, B. C.

HUDSON VIKING SPRINKLER CO.

Mr. H. A. Westenburg, St. Paul, Minn.

VIKING AUTOMATIC SPRINKLERS (CANADA) LTD.

Mr. R. G. Wallace, Toronto, Ontario

THE VIKING CORPORATION

Mr. J. W. Radford, Mr. Frank A. Rider, Hastings, Michigan

There is now a Schieber unit to suit *Every* budget

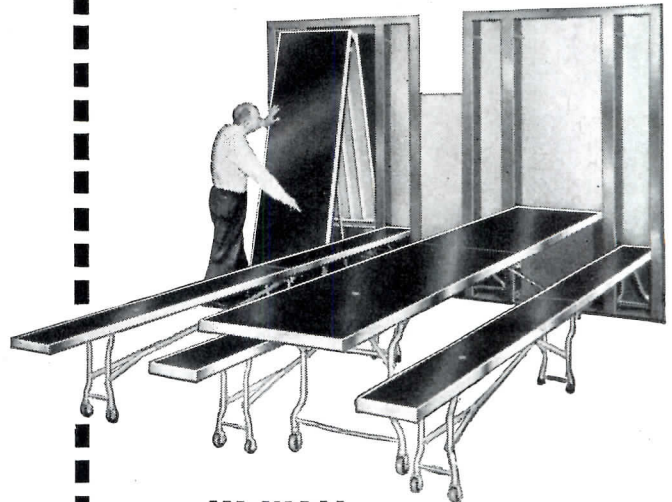

IN-WALL All-steel. Tops the line. Proven by 16 years service. Units remain rigidly attached to pockets at all times.

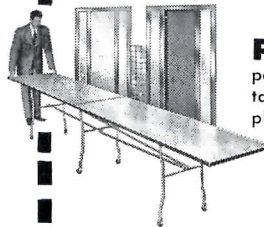
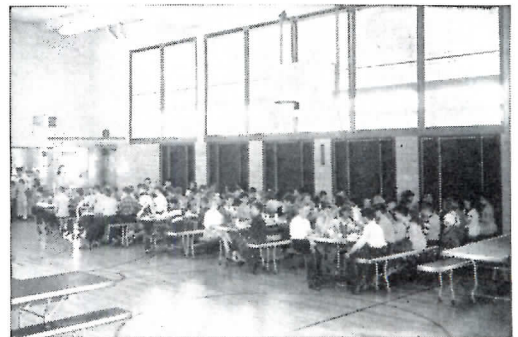

PORT-A-FOLD Wall pocket type. Units detach. Tops of tables and benches $\frac{3}{4}$ " reinforced plywood, heat-resistant plastic.

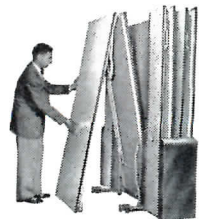

MOBIL-FOLD Tables and benches (Port-A-Fold type) fold into caster-equipped carrier that rolls to storage area.

Let us supply complete information

In-wall Port-a-Fold Mobil-Fold

Schieber Sales Company

BRIGHT MOOR STATION, DETROIT 23, MICHIGAN

THE RECORD REPORTS

WASHINGTON (Cont. from p. 234)

Federal share, \$591,502,161; projects in operation, 1338; their total cost, \$808,333,352; projects initially approved, 114; their total cost, \$100,647,845. All the jobs in the program will add 103,628 to the nation's supply. There are 358 health centers plus 71 combined with general hospitals.

- The Army has scheduled construction of approximately 30 armories with

money already appropriated — some 14 are ready to go ahead when final site selection is made, the others are in preliminary stages of development. The first armory construction appropriation was \$13 million in 1950. A total of 39 buildings was erected with that money, and six existing buildings purchased. The 1951 appropriation has been partially spent on 17 new buildings, and \$5 million of the unspent money will go

toward 14 of the proposed 30 new buildings. Design of the new structures is standardized along contemporary lines. Basic plans (ARCHITECTURAL RECORD, June, 1952, page 14) call for 200-, 400- and 600-man capacities, with each expandable in increments of 200 to a maximum 1000-man capacity. Since this type of building can be classified in the school building category for zoning purposes, there is considerable flexibility in choice of sites.

- The Housing and Home Finance Agency announced approval of temporary loan and capital grant allocations to Birmingham, Ala.; but there was a catch. Director James W. Follin of HHFA's Slum Clearance and Urban Redevelopment Division said final contracts would not be tendered until a "satisfactory" development plan was shown to HHFA — and this spelled non-discrimination, a delicate problem, naturally, in Birmingham. Amount of the temporary loan allocation was \$4,058,000; the capital grant fund, \$858,780. The local housing authority is reported to be well along with its plans; but a rumor had grown that the Federal agency would extend the money without assurance of non-discrimination in the units to be built. Putting this report at rest, Mr. Follin wrote the local authority that there could be no barring of Negroes, or any other occupants, on race, creed or color grounds if Federal contracts were to be valid.

- Federal Housing Administration modified one of its Mortgage Property Requirements to permit homes with more than two bedrooms each to qualify for mortgage insurance even though those bedrooms in excess of two do not have direct access to a bathroom or powder room. The move was made to qualify one and one-half story houses where bedrooms in finished attics might not have access to bath facilities on the same floor. Such design will now qualify for mortgage insurance if the specific plan under consideration has "a high degree of continuing marketability."

- Slum clearance recap: more than 200 capital grant reservations are now outstanding. Local programs have been initiated in 161 localities, and development of 50 projects is authorized in 23 places. These carry promised Federal funds of just over \$100 million. All projects involve about 5000 acres or nearly eight square miles.

(More news on page 240)

quiet, please:

library.

specifications:

number 1 sliding door hardware by

Grant

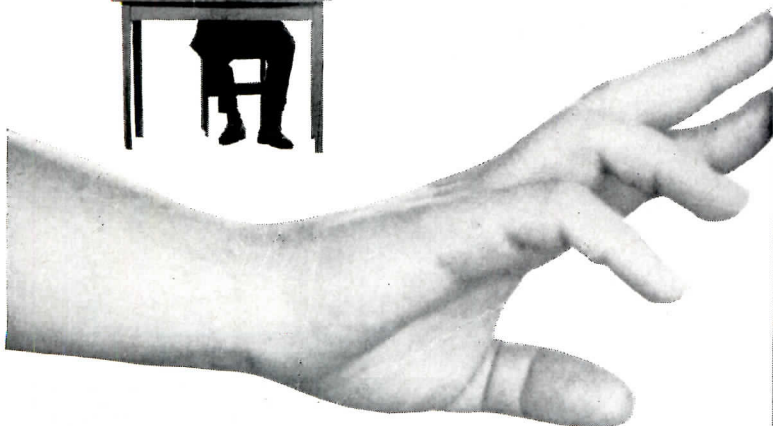

*for complete catalog write to
Grant Pulley & Hardware Company
31-71 Whitestone Parkway, Flushing, N. Y.*

Hardware: Grant no.1 sliding door hangers

Location: Firestone Library, Princeton University

Application: sliding doors for individual reading rooms

Architects: O'Connor & Kilham



Richard Garrison

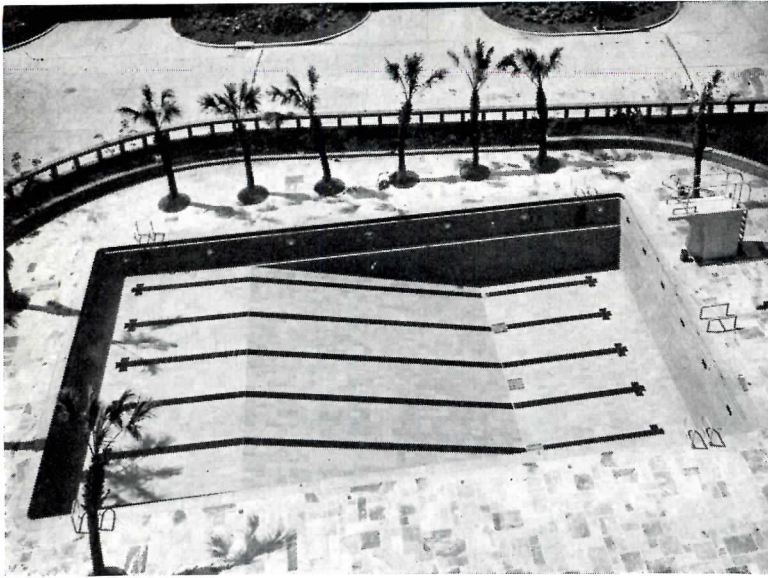

SWIMMING POOL

The Prudential Insurance Co. of America
Southwest Home Office, Houston, Texas

Kenneth Franzheim, *Architect*
W. S. Bellows Construction Corp., *Builders*

The overflow rim, floor and side walls of the pool are a cool green. Tread surface around edge of pool is sanded for maximum slip resistance; color is tan. Lane markers, ladders and numerals that mark water depth, are of contrasting black for easy visibility. Architectural Terra Cotta was specified throughout.

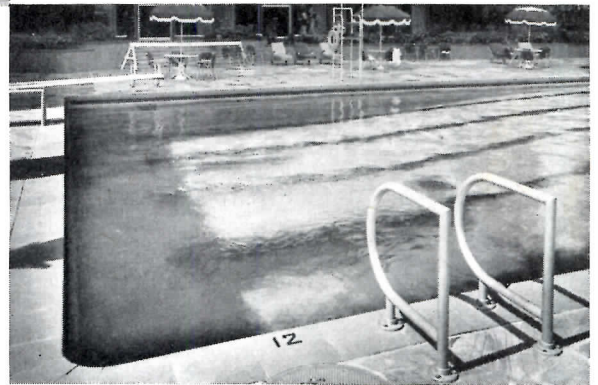

Modern pools
are sleek, colorful
...they're made of
Architectural Terra Cotta

Indoors or out, up North at Princeton University or deep in the heart of Texas, you'll see Architectural Terra Cotta's beauty reflected in the smartest pools. This time-proved material is custom-made, in an unlimited range of brilliant colors or delicate tints, in individual units large or small, plain surfaces or decorative sculpture. Because of its unrivaled versatility, Architectural Terra Cotta is now specified more than ever before...not only for pools but for mercantile, industrial, and monumental construction, and for modernization. If you haven't investigated the many advantages of modern Terra Cotta for interiors or exteriors, write for up-to-date data.

Construction detail, data, color samples, estimates, advice on preliminary sketches, will be furnished promptly without charge on Architectural Terra Cotta and Ceramic Veneer.

**FEDERAL
SEABOARD
TERRA COTTA
CORPORATION**



10 East 40th Street, New York 16, N. Y.
Plants at Perth Amboy and South Amboy, N. J.

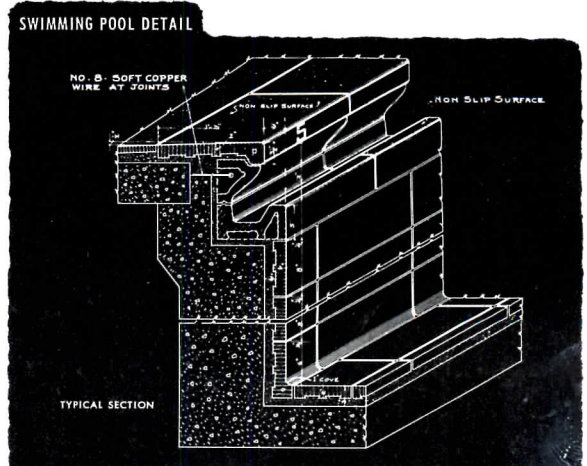

(Continued from page 238)

ON THE CALENDAR

Current through Jan. 17: Houses of Architects; houses built by architects for themselves — Philadelphia Art Alliance, 251 S. 18th St., Philadelphia.

Jan. 5-7: 1954 Annual National Joint Conference on Church Architecture, sponsored by Church Architectural

Guild of America and the Bureau of Church Building and Architecture of National Council of the Churches of Christ in the U. S. — Hotel Andrew Jackson, Knoxville, Tenn.

Jan. 6-24: Sculpture for Churches — Philadelphia Art Alliance, 251 S. 18th St., Philadelphia.

Jan. 7-9: The Metropolis in Modern Life: a Bicentennial Conference — Columbia University, New York City.

Jan. 12-14: Annual meeting, National Constructors Association — Hotel Commodore, New York City.

Jan. 14: Technical Development and Its Impact on Architectural Esthetics, fourth in a series of forums on "The Impact of Science and Materialism on the Arts Today" — Architectural League of New York, 115 E. 40th St., New York City.

Jan. 17-21: 10th Annual Convention, National Association of Home Builders — Conrad Hilton and Sherman Hotels, Chicago.

Jan. 18-22: Winter general meeting, American Institute of Electrical Engineers — Hotels Statler and McAlpin, New York City.

Jan. 20-Mar. 5: International Exhibition on Low-Cost Housing, organized by the Ministry of Works, Housing and Supply — New Delhi, India.

Jan. 24-27: Annual convention and show, Mason Contractors Association of America — Sherman Hotel, Chicago.

Jan. 24-27: Annual meeting, American Society of Heating and Ventilating Engineers — Rice Hotel, Houston, Tex.

Jan. 25-28: Plant Maintenance and Engineering Show and Conference, produced by Clapp & Poliak Inc. — International Amphitheatre and Hotel Conrad Hilton, Chicago.

Jan. 27-29: Tenth Annual Technical Conference, Society of Plastics Engineers — Royal York Hotel, Toronto, Ont.

Jan. 28-29: Canadian Conference on Prestressed Concrete — Hart House Theatre, Toronto, Ont.

Jan. 28-31: Annual meeting, Society of Architectural Historians — Bellevue-Stratford Hotel, Philadelphia.

Feb. 3-5: Ninth Annual Conference of the Reinforced Plastics Division, Society of the Plastics Industry — Edgewater Beach Hotel, Chicago.

Feb. 11: Technical Development and Its Impact on Painting: fifth in a series of forums on "The Impact of Science and Materialism on the Arts Today" — Architectural League of New York, 115 E. 40th St., New York City.

Feb. 11-13: 1954 Convention, National School Boards Association — Chalfonte-Haddon Hall, Atlantic City, N. J.

Feb. 13-18: American Association of School Administrators, National Education Association — Atlantic City, N. J.

Feb. 21-27: National Engineers Week, sponsored by the National Society of Professional Engineers: theme, "Engi-

**YOU TAKE THE *First* STEP
WE'LL TAKE THE *Second***

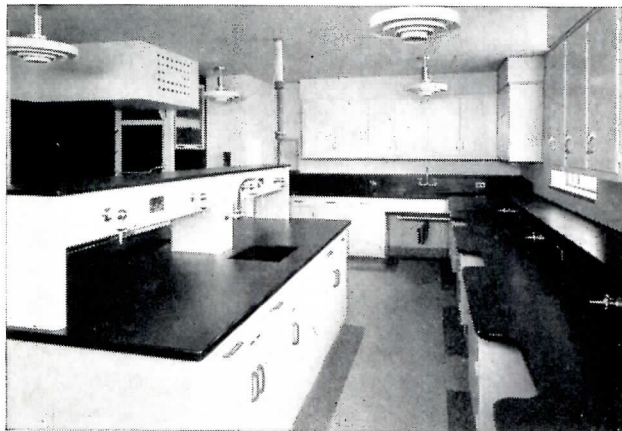

WITHOUT COST TO YOU

More and more architects are taking advantage of this helpful service rendered without cost by Kewaunee's staff of Laboratory Engineers. You, too, will want to profit by Kewaunee's 50 years of experience in equipping America's finest Hospitals and Laboratories.

It's a good plan to rush floor plans to Kewaunee—early.

- You'll save time and money in handling the job
- You'll insure most efficient use of floor space
- You'll be sure of providing utmost working convenience for your client
- You'll provide economically for any future laboratory expansion

If they're ready—send your floor plans Today. But if your Hospital or Laboratory program is not that far advanced, and you simply want to see what Kewaunee has to offer in modern cabinets, storage cases, nurses' stations, laboratory desks, instructors' desks, sinks and latest design fume hoods for handling radioactive and toxic materials, etc., ask for Catalog and helpful literature of Kewaunee Laboratory and Hospital Equipment. Specify whether job calls for wood or metal equipment and is for Hospital or Laboratories for Educational or Industrial Institutions.

ADDRESS:



J. A. Campbell, President

5046 S. Center Street • Adrian, Mich.

Sales Representatives in Principal Cities

1ST

You send us your Hospital or Laboratory Floor Plans.

2ND

We'll send you carefully engineered layout.



Wall Sink No. 210

(Continued on page 242)

Alabama Beautifies its State Capital with Architectural Concrete



In 1937 the State of Alabama built its Highway Department Building (above) with architectural concrete. It was so pleasing the Archives and History Building (upper right) followed in 1940.

When it was decided, a decade later, to build additional structures, the beauty and outstanding performance of the Highway and Archives Buildings led to the choice of architectural concrete again. The State Office Building (middle right) now is being built. Construction of the Public Health Building (lower right) starts this year.

These structures in Alabama's capital illustrate the beauty and adaptability of architectural concrete for public buildings. It is equally adaptable to schools, hospitals, apartments, churches and industrial and commercial buildings.

Architectural concrete fulfills every structural requirement too—durability, strength, firesafety, low maintenance expense and *low annual cost*.

More and more architects are discovering that architectural concrete is the ideal medium for giving form to their finest designs. For more information write for free, illustrated literature, distributed only in the United States and Canada.



Architects: for Health Building, Charles H. McCauley, Birmingham; for others, Warren, Knight & Davis, Birmingham. Structural engineers: for Health Building, Strickland and Associates, Birmingham; for others, Carl Wilmore, Birmingham. Construction: Highway and Archives Buildings, WPA; State Office Building, Ray M. Lee Company, Atlanta, Ga.; Health Building, Batson-Cook Company, West Point, Ga.

PORTLAND CEMENT ASSOCIATION

Dept. 1-8, 33 West Grand Avenue, Chicago 10, Illinois

A national organization to improve and extend the uses of portland cement and concrete . . . through scientific research and engineering field work

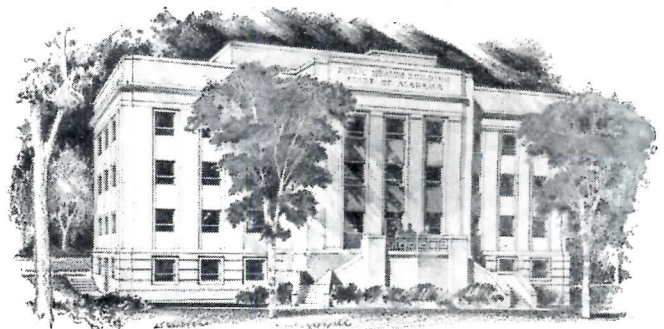

THE RECORD REPORTS

(Continued from page 240)

neering, Builder of a Strong America."

Feb. 23-Mar. 27: 1954 Gold Medal Exhibition of architecture, mural decoration, sculpture, design and craftsmanship in native industrial art, landscape architecture and engineering — Architectural League of New York, 115 E. 40th St., New York City.

Mar. 2-5: Department of Audio-Visual Instruction, National Education Association — Chicago.

Mar. 4-6: National Conference on Higher Education, Association for Higher Education, National Education Association — Chicago.

Mar. 4-Apr. 4: Gio Ponti and Gyorgy Kepes; an architecture and design exhibit — Institute of Contemporary Art, 138 Newbury St., Boston.

Mar. 8-11: National Electrical Manufacturers' Association — Edgewater Beach Hotel, Chicago.

Mar. 10-12: 40th Annual Convention, Michigan Society of Architects — Hotel Statler, Detroit.

Mar. 11: Technical Development and Its Impact on Sculpture, sixth in a series of forums on "The Impact of Science and Materialism on the Arts Today" — Architectural League of New York, 115 E. 40th St., New York City.

Mar. 15-19: Tenth Annual Conference and Exhibition, National Association of Corrosion Engineers — Kansas City.

Mar. 22-26: First annual Southern Homes Show, sponsored by Textile Hall Corporation — Textile Hall, Greenville, S. C.

FIREPLACE

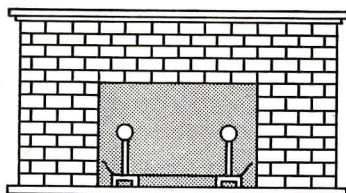

OR GAS APPLIANCE

each requires
the right
vent!

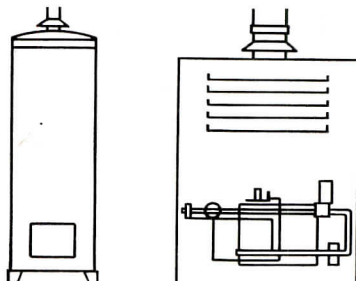

Everyone knows that a correctly designed chimney is essential to remove smoke and insure a properly functioning fireplace. But when it comes to venting gas appliances, some still believe that any kind of pipe, or even an unused chimney, will do the job.

Now the latest and most complete venting research yet undertaken has shown what conditions are necessary for proper gas venting. It proves the importance of a properly designed vent and demonstrates conclusively the superiority of Metalbestos, an insulated double-wall vent pipe, over other commonly used types.

METALBESTOS is designed specifically for venting gas appliances

Here are the reasons why you can be sure of better, safer venting when you specify Metalbestos:

- insulated, double-wall construction
- inner hot stack carries off vent gases without condensation
- cooler outer pipe protects surrounding walls
- made of corrosion-resistant aluminum, won't break or crack, lasts the lifetime of the house
- easy, fast installation with quick couplings and adjustable fittings

For the best venting job, always specify

METALBESTOS—the insulated vent

Write for free
VENT INSTALLATION
HANDBOOK

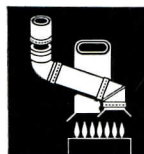

METALBESTOS

DIVISION

WILLIAM WALLACE COMPANY • BELMONT, CALIF.

Contains complete, up-to-date information on gas appliance venting and many helpful installation tips. Based on latest authoritative venting research. For your copy write to Dept. L-1451

OFFICE NOTES

Offices Opened

• Stanley James Goldstein, A.I.A., has announced the opening of his offices at 65 S. Orange Ave., South Orange, N. J.

• G. B. Gusrae, engineering consultant on vertical transportation, announces the opening of an office at 6 E. 39th St., New York 16, N. Y.

• James S. Liberty, A.I.A., has opened an office for the general practice of architecture. His address is Main Building, Medical Arts Square, 801 Encino Place N. E., Albuquerque, N. M.

• Douglas C. Morris has announced the opening of an office for the practice of architecture at 55 Bay Shore Drive, Bay City, Mich.

• Byron E. Porter, A.I.A., announces the opening of his offices at N. 4111 Whitehouse St., Spokane 8, Wash.

New Firms, Firm Changes

• The new firm of Beretta, Greenslade, Clark & Collins, Inc., has succeeded to the engineering business of J. W. Beretta Engineers Inc. Members of the new firm are J. W. Beretta, William F. Greenslade Jr., Odis H. Clark Jr. and Malcolm A. Collins. Offices will remain at the Travis Building, San Antonio 5, Tex.

(Continued on page 244)

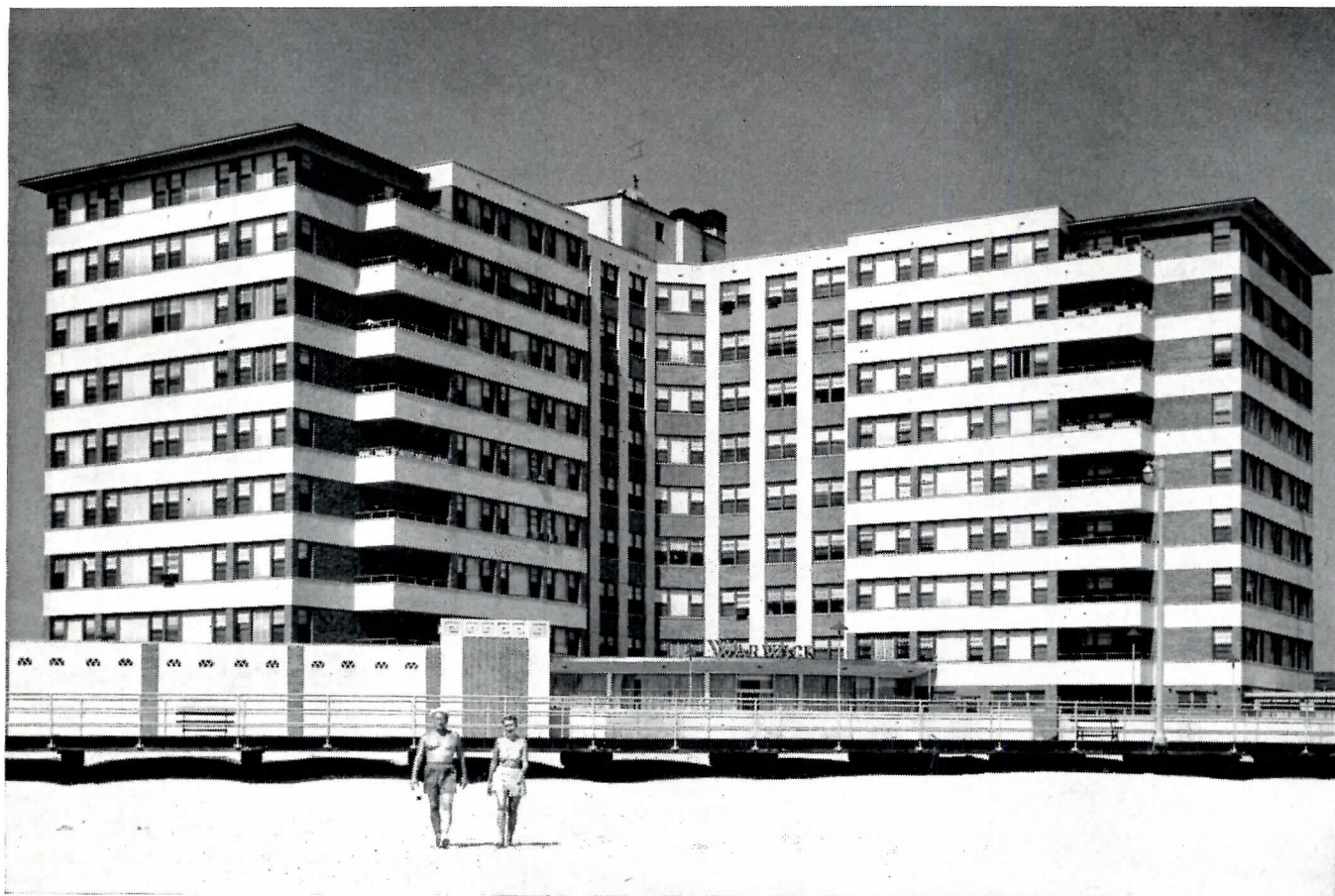

The Warwick, new 280-family apartment building at Atlantic City, N. J., is fire-resistant because it uses Bethlehem Open-Web Joists, combined with concrete floor slab and plaster ceiling.

STEEL JOIST CONSTRUCTION PROVIDES FIRE-SAFETY FOR OCEAN-FRONT APARTMENT BUILDING

This new apartment building, called The Warwick, stands only a stone's throw from the ocean at Atlantic City, N. J. It is nine stories high, and designed so that most of its 280 apartment units have a beach-front exposure.

A feature of the design of The Warwick is the minimum use of solid exterior walls, with maximum use of glass between floors. In fact, glass is utilized to a greater extent than masonry, with solid walls confined to horizontal spandrel bands, each apartment benefiting through increased natural light and air.

The ground floor of the yellow-brick structure is almost wholly dedicated to the community. It has a 200-seat restaurant and terrace, both overlooking an outdoor salt-water pool. There are also cabanas and shops.

One of the construction features of The Warwick is its resistance to the spread of fire. This is made possible through the use of Bethlehem Open-Web Steel Joists, in combination with concrete floor slab and insulating plaster ceiling. This type of construction is easy to install and provides a floor structure with a fire-rating of from one to four hours, depending upon slab thickness and type of plaster used.

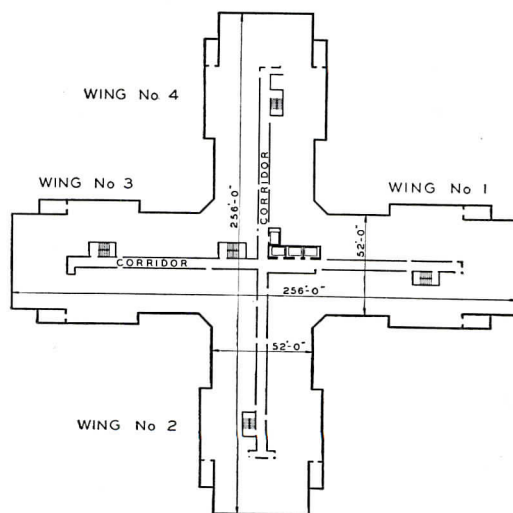

Typical floor plan of the 9-story structure.

Owners and Builders: E. J. Frankel Enterprises, Ephraim J. Frankel and Frank M. Steinberg.

Architects: Knopf and Oshiver.

Structural Engineer: R. E. McLaughlin.

... all of Philadelphia.

BETHLEHEM STEEL COMPANY, BETHLEHEM, PA.

On the Pacific Coast Bethlehem products are sold by Bethlehem Pacific Coast Steel Corporation. Export Distributor: Bethlehem Steel Export Corporation

BETHLEHEM OPEN-WEB STEEL JOISTS



THE RECORD REPORTS

(Continued from page 242)

• Kurt Gross, A.I.A., and Fred Marburg, Architect, have announced the formation of a partnership. The firm's address is 390 Park Avenue, San Jose, Calif.

• Harrison, Ballard & Allen, New York architectural firm, has announced the division of the partnership into two operations. Mr. Allen heads a city planning firm known as Harrison, Ballard &

Allen Inc., with offices at 243 E. 49th St., New York City, while Mr. Ballard is continuing his architectural practice at the firm's old address, 123 E. 77th St., New York City. The partnership will continue its practice, however, until existing obligation has been fulfilled.

• H. H. Waechter, A.I.A., has announced the opening of his practice as architect and city planner. His address is Box 268,

Rt. 2, Creswell, Ore. Mr. Waechter was formerly Associate Professor of Architecture at the University of Oregon.

• Lawrence H. Wilkinson has joined the architectural firm of Flewelling and Moody as Service Representative. The firm's address is 3112 Los Feliz Blvd., Los Angeles 39, Calif.

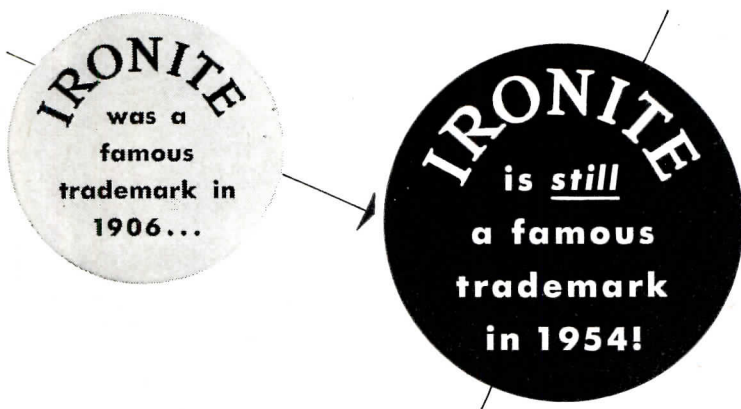

IRONITE[®]
WATERPROOFING
the Preferred Metallic Water Resistant Compound for Almost a Half Century!

FOR almost a half century leading architects and engineers have specified and used IRONITE[®] WATERPROOFING to protect masonry surfaces against water damage. IRONITE[®] has been used on hundreds of famous buildings. If you have a waterproofing problem involving foundations, basements, catch basins, boiler pits, elevator pits, swimming pools, cable vaults, settling basins, tunnels, bank vaults, oil tanks, water tanks, water reservoirs, concrete bridges, concrete fences, sewage disposal plants, molasses tanks, fuel oil tanks, hot water tanks, etc.—it will pay you to investigate IRONITE[®] WATERPROOFING—the guaranteed waterproofing method.

WRITE for your free copy of descriptive Bulletin No. 701 to Ironite Company, Suite 729, 208 S. LaSalle Street Building Chicago 4, Illinois

® T. M., Registered U. S. Pat. Office

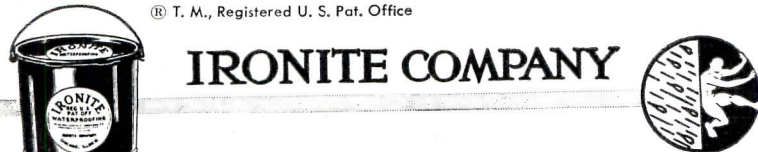

IRONITE COMPANY

New Addresses

Victor Bohm, A.I.A., 505 Fifth Ave., New York 17, N. Y.

Charles W. Cloud, Architect, 931 W. Third Ave., Columbus 8, Ohio.

August Diemeister, Architect, R. No. 1, Vanderbilt Parkway, Huntington, L. I., N. Y.

Eliasoph & Benkowitz, Architects, 6931 Côte des Neiges Road, Montreal, Quebec.

Cletis R. Foley, A.I.A., 317 S. Jefferson St., Peoria 2, Ill.

Mickelson & Fraser, Architects and Engineers, Mills Building, 16th Ave. at Memorial Ave., Intercity, Ont.

William W. Patterson, Architect, P. O. Box 2, Danville, Va.

ELECTIONS

• Brig. Gen. Dwight F. Johns, of Piedmont, Cal., has been elected president of the Society of American Military Engineers. Gen. Johns, who retired from the Army in 1949, has since served as staff engineer to the State of California Office of Civil Defense.

• Dean Cornwell has recently been elected president of the National Society of Mural Painters. His fellow officers include Helen Treadwell, first vice president; Virginia Wood Riggs, second vice president; Charles Baskerville, secretary; and Louis Ross, treasurer.

• American Community Builders, Inc., has announced the election of Philip M. Klutznick to the new post of chairman of the board. Nathan Manilow will succeed Mr. Klutznick as president of the corporation.

(More news on page 248)

Project: Manhattanville College,
Purchase, N. Y.
Architects: Eggers & Higgins,
New York, N. Y.
Fixture Manufacturer: Gruber Bros., Inc.,
Brooklyn, N. Y.
Lightingware: CORNING Alba-Lite and
PYREX brand Lenslites

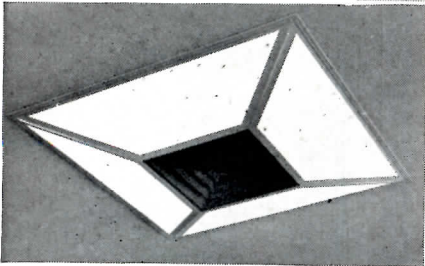
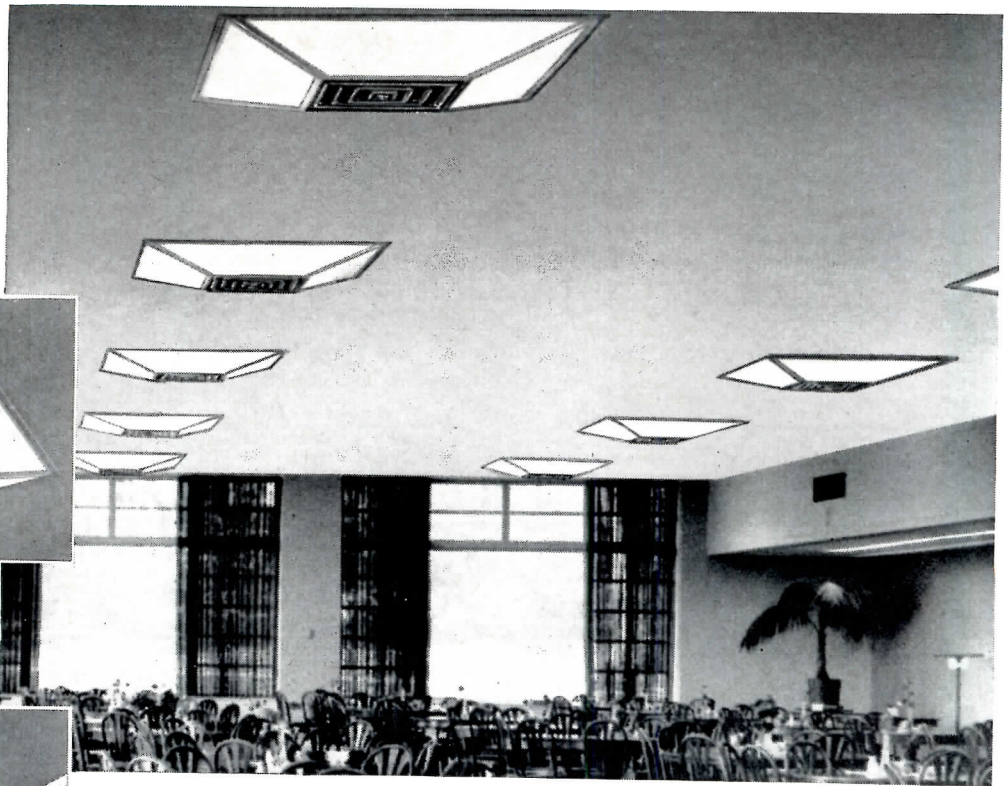

In dining room, air conditioning diffuser is integrated with lighting fixture. Light is pleasantly diffused by Corning Alba-Lite.



Classrooms, assembly hall, and corridors feature recessed fixtures also shielded with Alba-Lite low-brightness lightingware.



Stage of music auditorium is lighted with 32 recessed incandescent units shielded with PYREX brand Lenslites.

New ideas in lighting for girls' college realized with Corning lightingware

The ingenious combination of air conditioning with engineered lighting for five new buildings of Manhattanville College for Girls offers interesting possibilities for almost any type of building.

For example, in the dining room, air conditioning outlets are integrated in large fluorescent fixtures. Each one containing 24 lamps using a total of 600 watts. Sloping shields of Corning Alba-Lite diffusing glass afford low-brightness illumination of the proper intensity for dining.

In the assembly hall, three air conditioning outlets are spaced in each of seven rows of continuous recessed

troffers. Alba-Lite is used here also. It provides diffuse, high-level illumination, free of direct glare and harsh ceiling contrast.

Over the music stage of the auditorium, 32 incandescent units are shielded by PYREX brand Lenslites effecting a wide angle cutoff of the 150-watt lamps. They create a blanket of light of high intensity.

Corning offers a wide range of diffusing lightingware as well as Lens Panels and Lenslites. You will find these products adaptable to any lighting problem. Bulletin LS-35 tells you how to figure requirements. Send for it today.



CORNING GLASS WORKS
CORNING, NEW YORK

Corning means research in Glass

CORNING GLASS WORKS, Dept. AR-1, Corning, N. Y.

Please send literature checked:

- Architects and Engineers Lighting Handbook.
- Corning Lightingware for Fluorescent Lighting.
- Corning Lens Panels and Lenslites.

Name.....Title.....

Firm.....

Address.....

City.....Zone.....State.....

DETROIT'S CIVIC CENTER ADDS CITY-COUNTY BUILDING

The second unit of Detroit's Civic Center got under way recently when construction was begun on the City-County Building, a joint project of the city and Wayne County to house offices and courts for both governments. The courts are located in a 20-story building which is connected by a glass "link" to the 14-story office unit. Despite the

difference in height, the office unit has a greater floor area with its dimensions of 110 ft by 262 ft against the 76 ft by 155 ft area of the court building.

The court building contains 36 court rooms of varying sizes in accordance with the needs of each court. A separate corridor is provided for the judges' chambers and the jury rooms.



The office unit features a 500-seat amphitheater in which public meetings of the city's Common Council and the county's Board of Supervisors will be held. Both this room and the lounge beneath it are lighted from the north by a window (25 ft high and 98 ft long) which also affords a view of downtown Detroit. The first two floors of the office building have been allocated to departments expecting the largest flow of visitors, such as licensing and voter registration agencies. Other spaces, such as the civil service examining room, press facilities and the legal library in the court building, will be shared.

Architects for the building were Harley, Ellington and Day.

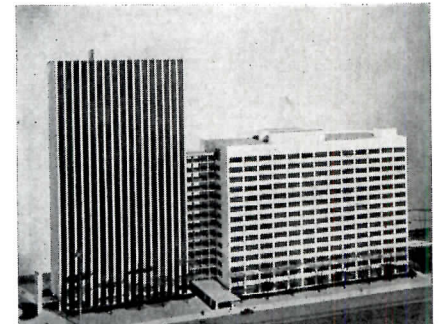

Above: Detroit's City-County Building, comprised of a 20-story court building and a 14-story office unit. Below: the north view of the building

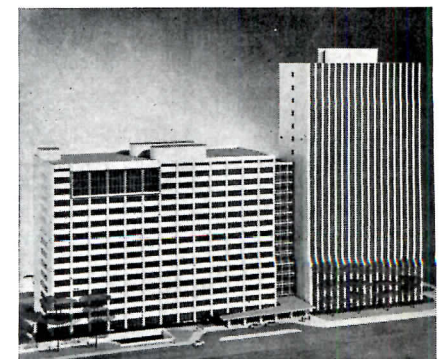

(More news on page 250)

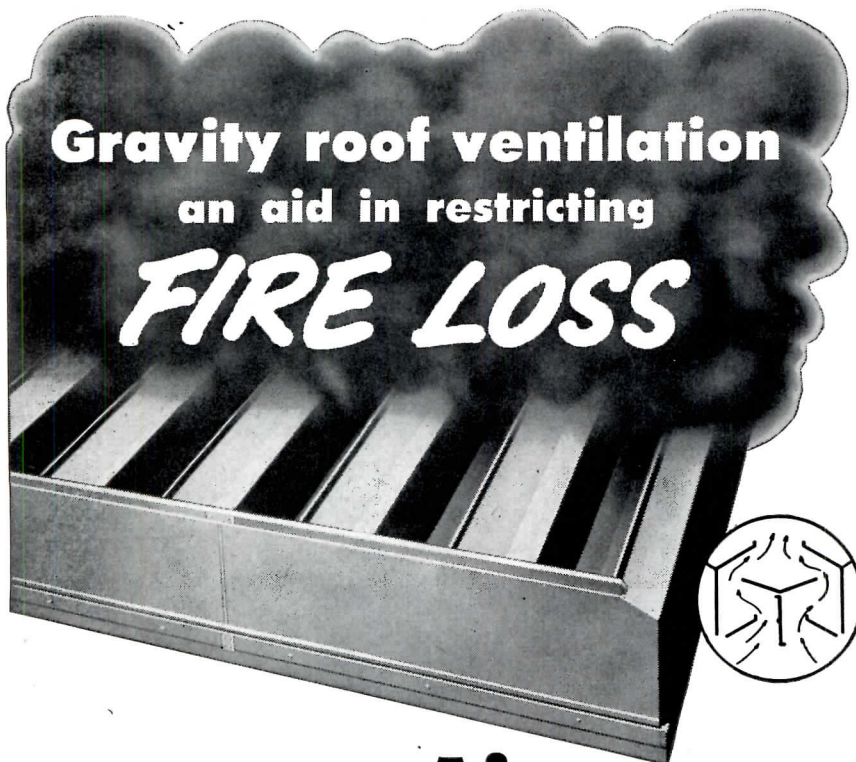

Swartwout Airmover
with fusible link damper release
... a valuable safety factor

The Livonia* fire taught an important lesson. Confined smoke and fumes prevented firemen from locating flame sources — cancelled efforts to keep fire from spreading. Large scale Swartwout Airmover roof ventilation would have released heat and dense oily smoke — fast — allowing more effective fire-fighting.

Airmover provides everyday economical roof ventilation adaptable to any type of building. Only 32 inches high, air travel is short, with practically no air friction. Fully weatherproof, with adjustable dampers. As a fire hazard provision, dampers can be weighted to open fully when an approved type fusible link releases operating bar. Investigate this valuable safety aid. Write for Bulletin AM-G.

* Livonia, Mich. — General Motors Hydramatic plant. See article in November "Fortune".

18511 Euclid Avenue, Cleveland 12, Ohio

The Swartwout Co.

Roof Ventilators and Ventilating Louvers

POWER PLANT EQUIPMENT • PROCESS INDUSTRY CONTROLS



244 of 261 Plumbing Inspectors say their choice of materials is **CAST IRON SOIL PIPE**

On November 4, 1953, the Institute wrote to 688 plumbing inspectors in cities scattered all over the U. S. These officers were asked about their preference in materials for house sewers, running from house to street, or from house to septic tank.

Of the 261 inspectors who replied, 244 said that for mechanical strength, root-proofness and permanence, they prefer **Cast Iron Soil Pipe and Fittings**. That's the opinion of men whose job is to safeguard public health.

**How the sound movie,
"PERMANENT INVESTMENT"
can be of help to
the architect**

Today, more than ever before, architects are being consulted about materials and methods that affect the home as a whole. Many clients seek the architect's advice on the plumbing drainage system, not merely in the house itself, but including the sewer line from house to street, or house to septic tank. The Institute will be glad to arrange for a free showing of "Permanent Investment" to help any architect to demonstrate the importance of quality materials in plumbing drainage.

Every architect knows sound reasons for this overwhelming preference. Not only does cast iron soil pipe resist the damage of settling, moisture and root penetration, but its lead-caulked joints and its fittings take the rigors of rodding without damage. Many architects feel that their responsibility to clients includes the structure and all its connections, straight through to the street. That's why so many of them specify permanent cast iron soil pipe and fittings.

USE PERMANENT CAST IRON SOIL PIPE AND FITTINGS

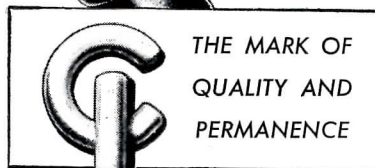

THE MARK OF
QUALITY AND
PERMANENCE

CAST IRON SOIL PIPE INSTITUTE

Dept. AR-1, 1627 K Street, N.W.,
Washington 6, D. C.

- Send educational folder, "Plumbing Drainage."
- Our local Club wants to see your movie, "Permanent Investment." Tell us how to arrange for free showing.

Name _____

Address _____

City _____ Zone _____ State _____

THE RECORD REPORTS

(Continued from page 248)

THREE WINNERS SELECTED IN BRIDGE COMPETITION

The American Institute of Steel Construction, in its 25th annual "Aesthetic Bridge Competition," has chosen three winners among steel bridges opened to traffic during the year 1952. Entries receiving awards were: in Class II, for bridges with spans under 400 ft costing over \$500,000, the Neches River Bridge,

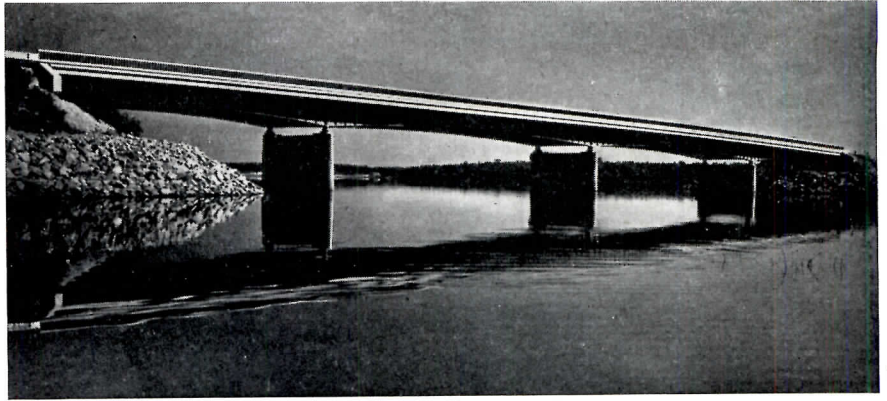

(1) Morris Ferry Bridge: designers, Corps of Engineers, Tullahoma District; fabricator, Nashville Bridge Co. (2) Neches River Bridge: designer, Texas Highway Department; fabricator, Bethlehem Steel Co. (3) S.E. Fourth Avenue Bridge: designer, Rader Knappen Tippetts Engineering Co.; fabricator, Nashville Bridge Co.

GROVE LABORATORIES,
Clayton, Missouri
Contractors & Engineers:
Fruin-Colnon Contracting Co.
Consulting Architects:
Jamieson & Spearl

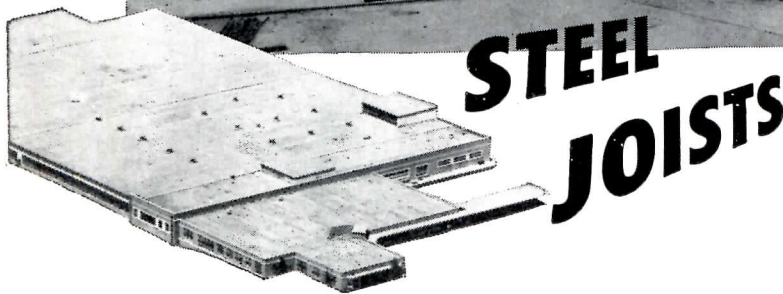
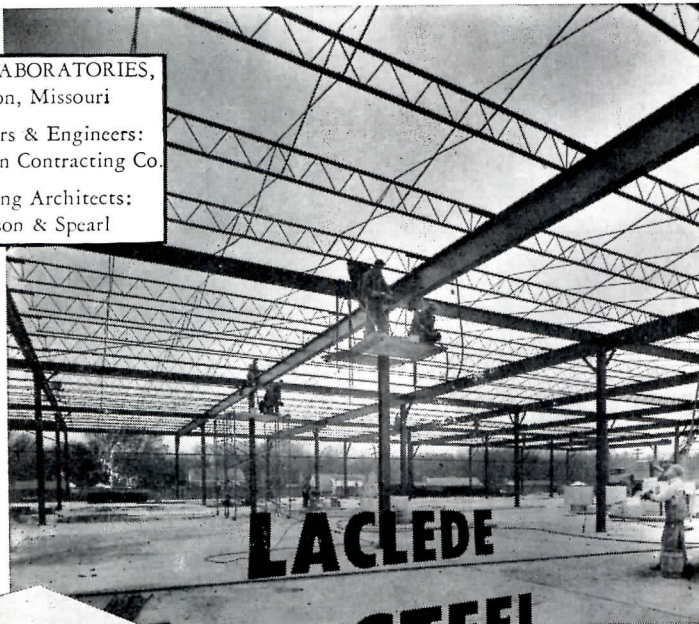

for **FRAMING LARGE AREAS**
ECONOMICALLY... QUICKLY

Specify These Laclede Products: Welded Wire Fabric • Form & Tie Wire • Multi-Rib Reinforcing Bars • Joists • Corrugated Steel Centering • Spirals • Conduit • Steel Pipe • Electrical Weld & Gas Weld Tubing



LACLEDE STEEL COMPANY
St. Louis, Mo.

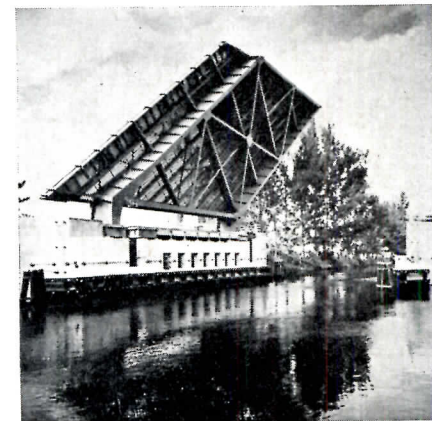

Beaumont, Texas; in Class III, for bridges with spans under 400 ft costing less than \$500,000, the Morris Ferry Bridge, Franklin County, Tenn.; and in Class IV, for movable bridges, the S.E. Fourth Avenue Bridge, over Miami Canal, Miami, Fla. There was no winner chosen in Class I, for bridges with spans of 400 ft or more.

A.I.A. President Clair W. Ditchy and A.S.C.E. President Daniel V. Terrell were on the jury, which also included Harris Armstrong, A.I.A., J. Woolson Brooks, A.I.A., and Gordon Washburn, Fine Arts director at Carnegie Institute of Technology.

(More news on page 252)

GREATER ECONOMY IN ARCHITECTURAL CONCRETE!



Mount Royal Manor Apartments, Duluth, Minn. Contractor-Owner: W. C. Smith, Inc. Architect: A. Reinhold Melander—both of Duluth.

Owner-builder notes "lower costs" with Atlas Duraplastic* Cement

GOOD WORKABILITY is a prime essential in the success of architectural concrete since it serves as both a structural and a finish material. W. C. Smith, whose firm is contractor and owner of the Mount Royal Manor Apartments in Duluth, found "concrete made with Duraplastic has better workability, requiring less effort in placing, and that helps lower costs."

When you design for or build with concrete, it will pay you to consider the special advantages of Atlas Duraplastic, the original air-entraining portland cement.

You'll find it requires less mixing water for a given slump. And its more plastic mix aids proper placement, resulting in *improved surface appearance*. Moreover, since entrained air minimizes bleeding, or water gain, and segregation, concrete made with Duraplastic is also *fortified against the effects of freezing-thawing weather*. Both features add up to better concrete.

YET DURAPLASTIC COSTS NO MORE! It sells at the same price as regular cement and requires no unusual changes in procedure. Complies with ASTM and Federal Specifications. For more information, write Universal Atlas Cement Company (United States Steel Corporation Subsidiary), 100 Park Avenue, New York 17, N. Y.

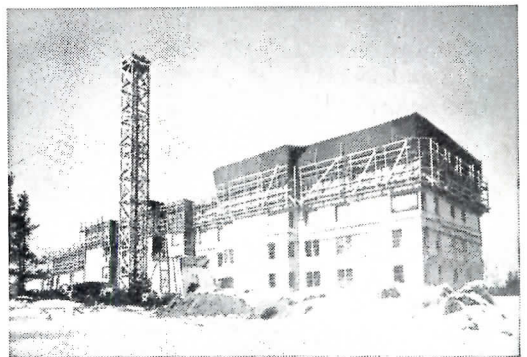

Construction goes ahead satisfactorily even in 20-below Minnesota weather. And since the mix is made with Duraplastic, finished concrete will have extraordinary resistance to freezing-thawing weather ahead!

*"Duraplastic" is the registered trade mark of the air-entraining portland cement manufactured by Universal Atlas Cement Co.

OFFICES: Albany, Birmingham, Boston, Chicago, Dayton, Kansas City, Minneapolis, New York, Philadelphia, Pittsburgh, St. Louis, Waco.

ATLAS®

AR-D-148R

DURAPLASTIC

AIR-ENTRAINING PORTLAND CEMENT

Makes Better Concrete at No Extra Cost



UNITED STATES STEEL HOUR—Televised alternate weeks—See your newspaper for time and station.

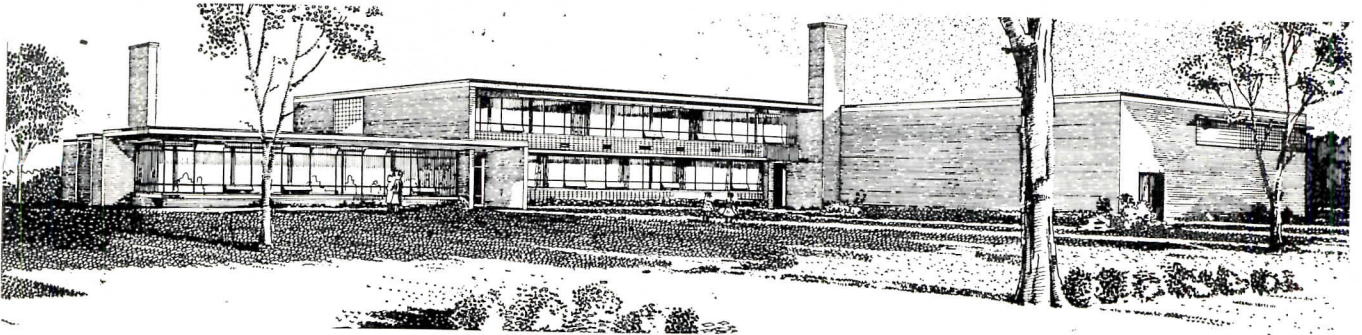

**BUILT FOR EXPANSION:
TWO LOW-COST SCHOOLS**

Elmhurst, Ill., a suburb west of Chicago, is building two new elementary schools to take care of a population increase that has averaged 750 families a year for the last six years and is expected to continue till the population has risen from the present 23,000 to 35,000 in 1960.

The two schools, now under construction, are expected by Architects Cone and Dornbusch to be completed for something less than \$12 per sq ft—a figure they say is especially good in their area for school construction of comparable materials and facilities. Exclusive of landscaping, equipment and architectural fees, costs for the Jefferson School (above) are placed at \$376,783 and for the Emerson School at \$362,937.

The schools will each contain 13 classrooms to accommodate 390 pupils and provide for kindergarten through sixth grade. Each will also have a gymnasium planned for community as well as school use, kitchen, nurse's room, special-purpose room and administrative offices.

Three classrooms in the Jefferson School and five classrooms and a special-purpose room in the Emerson School will be left unfinished pending anticipated future enrollment increases. Additional expansion which might be required later has been made as easy as possible by use of a repetitive structural system with a 10-ft module determining classroom and window dimensions. Construction is reinforced concrete and completely fireproof with brick cavity wall construction. Classrooms are of painted concrete block, with acoustical ceilings and fluorescent lighting. Colors are planned in combination with lighting and fenestration to reduce glare and eye strain and to allow a pleasing variety.

(More news on page 266)



what makes **imported**

CASTELL*

great?

Experience—193 years of it—
makes **CASTELL** Drawing Pencils and Leads great.

As you guide it on your drawing board with swift, bold strokes—the accumulated genius of almost two generations helps you achieve outstanding results.

On every count—smoothness, freedom from hard spots, opacity, strength, economy and “blueprintability”—CASTELL stands out like a giant among pygmies.

Give your creative ability the advantage of the *best* . . . and only a penny or two more brings you the best. Do as the Masters have been doing for generations—use CASTELL Drawing Pencils and Leads.

CASTELL



the drawing pencil
with the Master Degrees

9030 Imported
CASTELL Lead—7B
to 10H—with the
same unique qualities
that made CASTELL
9000 wood-encased
pencil famous.



A.W. FABER-CASTELL
PENCIL COMPANY INC., NEWARK 3, N. J.

*Imported from West Germany



Radiant heat? Now **MATICO** asphalt tile offers research proof of thermal efficiency!

Low loss . . . low cost! These are the two big benefits of using MATICO Asphalt Tile Flooring with radiant-heat, concrete-slab construction. According to an independent report, MATICO Asphalt Tile Flooring permitted 46 BTU per hr. per sq. ft. output compared to 47 for bare concrete — a difference of only 1 BTU per hr. per sq. ft. Moreover, MATICO Asphalt Tile Flooring exceeds Federal Specification requirements for indentation even when water in the heating pipes measures 120°.

That's why architects, engineers and builders specify and recommend MATICO Asphalt Tile Flooring. This colorful, durable flooring material is precision-made, easy to install, quiet and comfortable underfoot . . . provides a high degree of thermal efficiency and indentation resistance and is exceptionally low in cost.

If you'd like a copy of this report, write Department 8-1 today. We'll forward you one immediately.



MASTIC TILE CORPORATION OF AMERICA

Joliet, Ill. • Long Beach, Calif. • Newburgh, N. Y.

Manufacturers of: Aristoflex • Confetti • Parquetry • Asphalt Tile • Cork Tile • Plastic Wall Tile

sult is a public building program, exclusive of schools, showing a grand total for the coming three years of \$2,374,000,000 (not including land costs).

Other than public buildings, the major elements of community services from a capital construction point of view are water works; sewerage projects; streets and urban highways; power, transit, gas, port facilities and airports.

The American City was asked to estimate and forecast activities in the first three categories a number of times last year. A considered estimate was furnished by request and published in the 1954 Market Data Number of *Industrial Marketing* for June 25, 1953 (page 377). We said: "Actual projects in 1952 totaled about \$400,000,000 for water works, \$600,000,000 for sewerage proj-

ects and \$350,000,000 for streets." They are running about 18 per cent heavier on the average in 1953.

Our estimates for these three categories for the next three years are also shown in table 2. Adding the public building estimate we get a grand total municipal construction estimate (exclusive of schools) for the three years 1954-55-56 of \$6,194,000,000.

The figures developed in tables 1 and 2 are obviously rough estimates; but they are not merely wild guesses. They reflect, in part, what we of *The American City* magazine believe to be a well-founded optimism as to the future of the municipal market. This future gives promise of substantial advances, both quantitative and qualitative, in new municipal services and in urban redevelopment.

Reasons for Optimism

Some special reasons for this optimism may be mentioned briefly:

1. The rapidly growing population of the United States and the increasing concentration of that population in cities, towns, and villages make mounting demands on municipal buildings and community facilities.

2. Within metropolitan areas the current and growing trek to the suburbs is developing a keen competition between the central cities and their satellite communities for public improvements and services that will help the suburbs to grow sanely and the metropolitan centers to redevelop soundly.

3. The many libraries, auditoriums, and public recreation facilities proposed for construction during the next three years are indicative of the desire of urban dwellers for communities of which they may be proud and in which they may find life increasingly worth living.*

4. The fact that nearly 13 per cent of the number and 40 per cent of the cost of the buildings reported in *The American City's* questionnaire are water, sewerage, and incineration plants seems to promise a further upsweep in sanitation.

(Continued on page 258)

MICHAELS adjustable ASTRAGALS

KEEP DOORS CLOSED

... help eliminate drafts and air currents ... keep out dirt and dust. Made of extruded bronze, aluminum or nickel, they are simple, practical, rugged, easily installed and adjusted. Michaels Adjustable Astragals are available in several styles, two of which are shown below.

Type A

may be applied to either wood or hollow metal bevel doors, or as a stop bead.

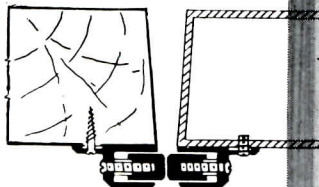

Type E

is for bullnose hollow metal or wood doors (double acting).

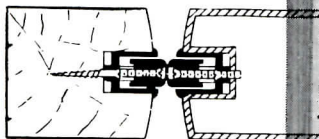

Michaels Adjustable Astragals compensate for the expansion and contraction of doors, and close, as nearly as possible, a door of any type. Write today for complete details and prices.

OTHER MICHAELS PRODUCTS

- Bank Screens and Partitions
- Bronze Doors
- Aluminum Doors
- Elevator Doors
- Store Fronts
- Name Plates
- Grilles and Wickets
- Kick and Push Plates
- Push Bars
- Cast Thresholds
- Lettering
- Check Desks (standing and wall)
- Lamp Standards
- Marquises
- Tablets and Signs
- Extruded Thresholds
- MI-CO Parking Meters
- Museum Trophy Cases
- Inurnment Urns
- Stair Railings

Literature on any or all Michaels products will be sent on request.

THE MICHAELS ART BRONZE CO., INC.

234 Scott Street, Covington, Ky.

Manufacturers since 1870 of many products in Aluminum, Bronze and other metals

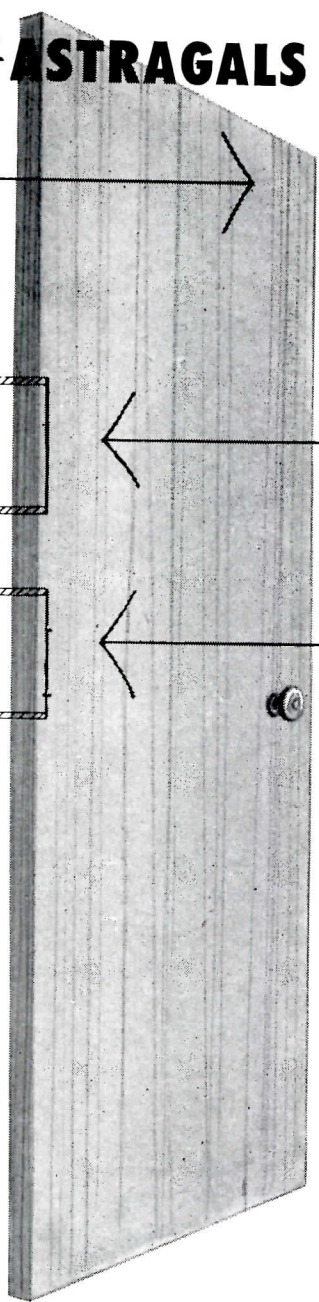

* For ARCHITECTURAL RECORD'S latest Building Types Study on Social and Recreation Buildings, see pages 146-168.

when you're building houses...



**GIVE
THEM
AIR!**

safeguard against paint blister and peeling with
"MIDGET" LOUVERS

Prevent condensation and eliminate destructive sweating and dampness. Ventilate danger spots with inexpensive "MIDGET" LOUVERS — the rust proof, all-aluminum ventilating unit that quickly gives condensation problems the air. Built-in screen keeps out insects, deflectors keep out rain and snow.

QUICK AND EASY TO INSTALL. No nails . . . no screws. Just drill a hole and tap into place. Special tension slots and swedge fasteners assure tight fit and firm, permanent anchorage.
2 types — for indoors or out — 6 different sizes



the "MIDGET" LOUVER co.
8 WALL STREET • NORWALK, CONN.

FROM ORIGINAL DESIGN — TO
FINAL INSTALLATION . . .

Wheeler
**LIGHTING ENGINEERING
FOLLOWS THROUGH!**

Available over the years to Architects, Industrial Engineers, Jobbers and Contractors at every level of field service, WHEELER FIELD SALES ENGINEERING is constantly at your service . . . ready to aid you in planning the best Lighting Layout for any standard Commercial or Industrial installation. And for special lighting problems, too, you can rely on Wheeler's unique technical assistance to provide the one best answer to your specific requirements.

Wheeler REFLECTORS Distributed Exclusively Through Electrical Wholesalers
MADE BY SPECIALISTS IN SKILLED LIGHTING EQUIPMENT SINCE 1881
275 Congress Street Boston 10, Massachusetts

**See how
inconspicuously**
STRAIPLINE
**fits into your
plans!**

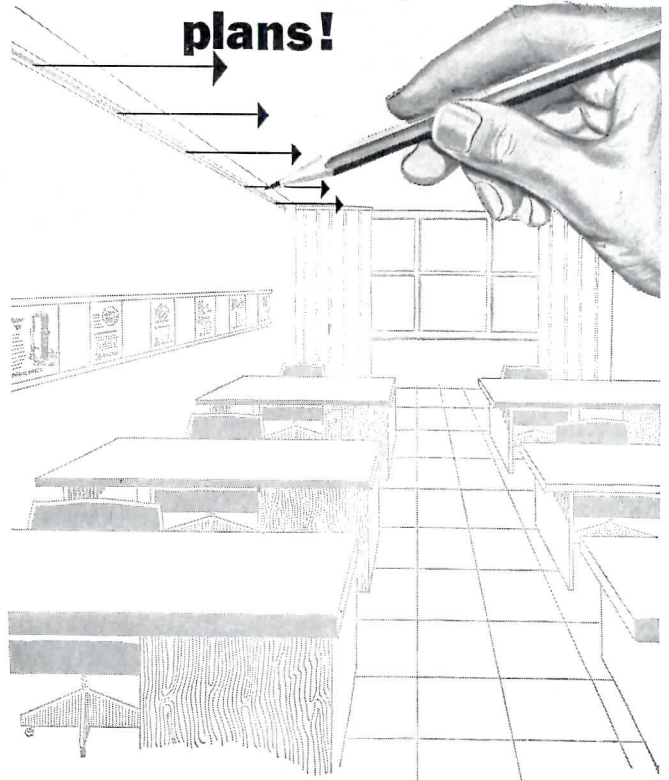

**Unlimited air distribution
provided by slender
continuous diffusers
...another AGITAIR first!**

Stripline diffusers offer complete application versatility. They are ideal for installation in shallow lighting coves...window stools for air curtaining of glass windows or exposed wall areas...side of furred beams... or as a decorative border blanketing the entire area with noiseless, draftless air distribution. Custom built with AGITAIR's patented diffusing vanes, Stripline diffusers create maximum mixing and aspiration... quick temperature equalization and correct air distribution over any desired length.

Write for your free copy of
Catalog S-100 today.

AGITAIR STRIPLINE

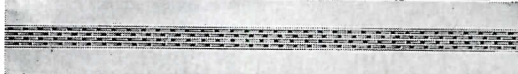

AIR DEVICES INC.
185 Madison Avenue, New York 16, N. Y.
AIR DIFFUSERS • FILTERS • EXHAUSTERS

Only **FAR-AIR***
gives you completely
automatic air filtration
with all these advantages!

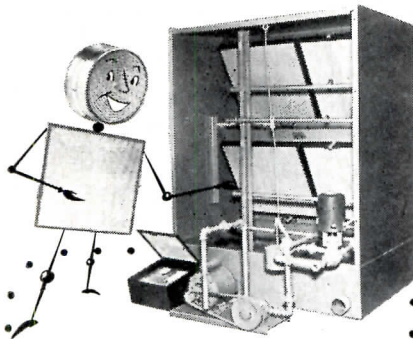

**FAR-AIR Self-Washing
filters clean air better . . .
provide these automatic
features, too!**

Washing, drying and oiling is controlled electrically on a pre-determined time schedule...*automatically!* Air cleaning efficiency remains constant. There is no liquid particle entrainment.

Water and dirt are flushed directly to sewer...*automatically!* There is no messy oil sump to collect sludge and create a fire hazard. Maintenance man-hours are reduced. Built-in controls guard against fire...*automatically!* These are Far-Air features:



- No entrainment
- No sludge—no oil sump
- Automatic fire control
- Minimum maintenance
- Easy installation

FAR-AIR Self-Washing filters give you more efficient, more dependable service. That's because FAR-AIR's exclusive herringbone-crimp media design permits progressive loading and free air flow. Find out today about completely *automatic* air filtration.

MAIL COUPON NOW FOR COMPLETE INFORMATION



*Trade Mark Reg.

FARR COMPANY

Manufacturing Engineers
CHICAGO • LOS ANGELES • NEW YORK
Mfg'd under license by Control Equip. Co., Ltd., Montreal, Canada

Farr Company, P. O. Box 10187 Airport Station
Los Angeles 45, California

Please send me information on FAR-AIR Self-Washing filters. I would would not like a Farr Field Engineer to discuss my air filtration problem with me.

Name _____
Company _____
Address _____

THE RECORD REPORTS

City Building

(Continued from page 254)

5. The fact that almost all large cities, and a substantial percentage of the smaller ones, now have an official city planning commission and a zoning board means that forethought is being increasingly given to community needs, including the planning ahead for future public buildings and public works. This movement has been aided by the fact that since World War II Congress has appropriated \$92 million in loans for use by state and local governments in planning for their future development. It is estimated that when the Eisenhower administration took over there was a backlog of \$6.2 billion worth of Federal, state, and local plans already blueprinted.

6. Still another reason for optimism is the increasing concern of local and national business and civic organizations with the building of better cities. Many of these bodies are serving as a check on foolish expenditures and a spur to worth-while community improvements.

7. I have made no comment on the highly controversial subject of the part that government — national, state, and local — is playing and might play in the improvement of housing conditions for families of low income and in aiding the cities to reclaim and redevelop their slums and blighted areas. But I am hopeful that the Eisenhower administration will develop a sound middle-of-the-road policy that will get the backing of Congress. In this connection, addressing the National Association of Housing Officials in Milwaukee on October 15, Administrator Albert M. Cole, of the Housing and Home Finance Agency, described slums as "economically unbearable and socially intolerable," and declared his conviction that provision of decent housing of low-income slum dwellers is, first of all, a responsibility of the local community and of private industry. But, said the Administrator, "under the present demands placed on local resources, I do not see how in most cities housing for such families can be provided in sufficient quantity without some subsidy aid from the Federal government."

The Employment Aspect

Though not of immediate sales value, there is another aspect of the huge lump

(Continued on page 262)

the Emblem of Quality since 1875



**TIME-SAVING
SIGNAL SYSTEMS**

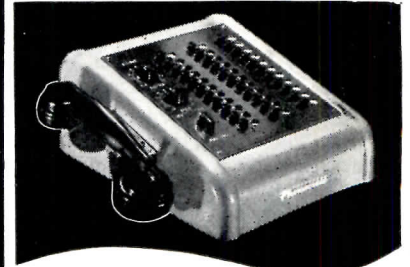

New Phonacall
Station Control Unit



Ward Station

Nurse, doctor and patient are happier, in the thousands of hospitals served with Faraday Signal Systems. Each part of the system is especially designed for hospital use, and is backed by seventy-eight years' experience in tailoring systems to the needs of hospitals, large or small. Whether planning a new system, or redesigning an old one, Faraday engineers can be helpful. Write today. No obligation.

HOLTZER-CABOT FARADAY STANLEY & PATTERSON

CONSOLIDATED BY:

SPERTI FARADAY INC.

ADRIAN, MICH.

BELLS • BUZZERS • HORNS • CHIMES • VISUAL
AND AUDIBLE PAGING DEVICES AND SYSTEMS

Send for your **FREE RLM**
SPECIFICATIONS BOOK...

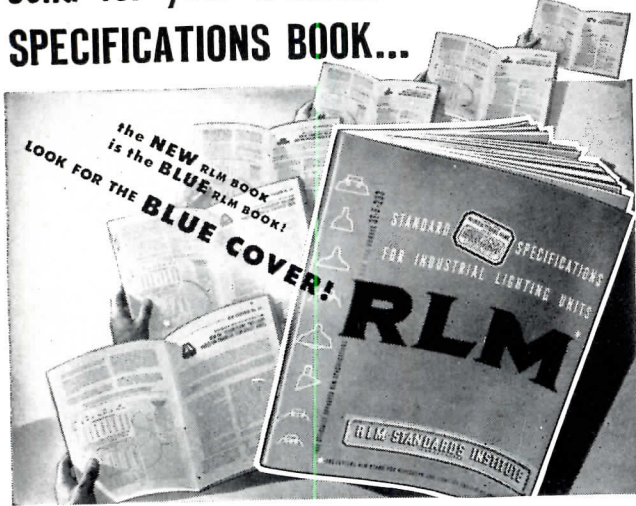

contains RLM quality specifications for 15 new units providing **GREATER UPWARD LIGHT** plus important revisions and additions to the other 68 RLM Industrial Lighting Equipment Specifications.

You are invited to send for your copy of this newly-published reference book on industrial lighting equipment. Now 52 pages, including long-awaited specifications for 48", 72" and 96" Upward Component units, which direct 20% to 30% of light upward. Specifications for all 83 types and sizes of RLM incandescent, fluorescent and mercury units have been brought

up-to-date in accordance with latest illuminating engineering developments. Your copy sent without cost or obligation... address request on your letterhead to:

RLM STANDARDS INSTITUTE, Suite 827,
326 W. Madison St., Chicago 6, Ill.



You'll always **Satisfy**
when you **Specify**
SARGENT Products

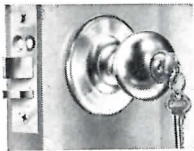

SARGENT INTEGRALLOCKS

give lifetime beauty and lifetime protection. Brass, bronze or aluminum finish. Have the famous **SENTRY BOLT**, plus locking set stops.



SARGENT LIQUID DOOR CLOSERS

are already installed on hundreds of thousands of doors. Many well-proven advantages.

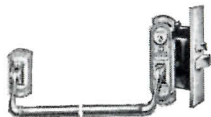

SARGENT EXIT BOLTS

permit emergency exit under all conditions. Collapsible latchbolt prevents jamming.

For complete data, specifications, please write to Dept. 31A.



SARGENT AND COMPANY

New York • NEW HAVEN, CONN. • Chicago
Builders Hardware and Fine Tools since 1864

TEST of TIME



Lawler's longer-lasting Quality
insures **YOUR** reputation!

Finished in polished chrome, the model BE Exposed Thermostatic Shower Mixing Valve has all sliding parts of stainless steel for corrosion-proof operation. Check valves with Lawler's exclusive tapered seats, and neoprene "O" rings, will not leak even at the lowest pressure differentials. Actual tests show that the model BE gives highest degree of control... **BE SURE** type BE

... WITH "BE."

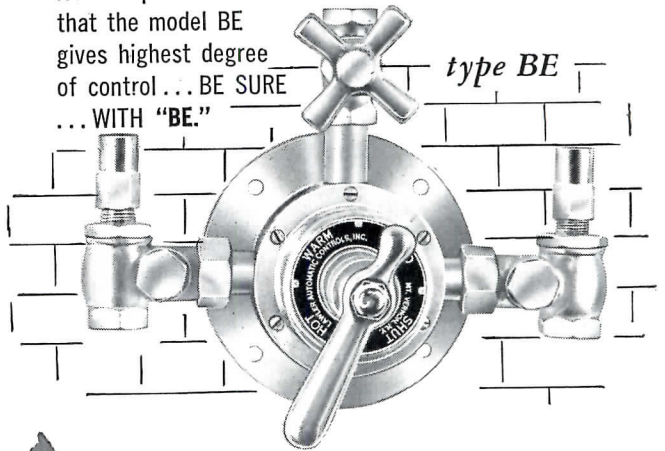

COMPARATIVE CHECK LIST

LAWLER "BE" SHOWER MIXING VALVE	Product "A"	Product "B"
Completely Polished Chrome	✓	
Integral Shut Off	✓	✓
Stainless Steel in All Sliding Parts	✓	
Positive Hot Non-Scald Shut Off	✓	✓
Check Valves with Tapered Seats and Neoprene "O" Rings	✓	

List the facts...
Check them off...
Lawler comes out first every time!
YOUR REPUTATION is protected!



"Performance-Tested" for
Longer Life



LAWLER AUTOMATIC CONTROLS, INC.
453 North MacQuesten Parkway Mount Vernon, New York

Make a note!

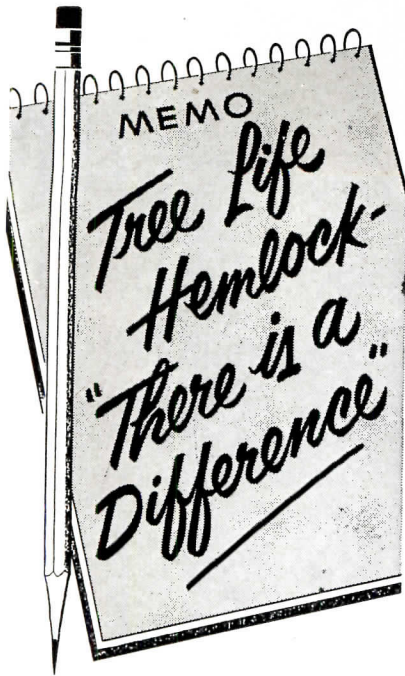

Right! West Coast Hemlock should never, *never* be confused with Eastern Hemlock. West Coast Hemlock (*Tsuga heterophylla*) is an entirely *different* species. TREE LIFE West Coast Upland Hemlock, grown only at high altitudes on western slopes of the Cascade Mountains, is a superior wood for many uses—the finest type of Hemlock grown! Check its features!

- West Coast Hemlock is strong. Has fewer and smaller knots.
- West Coast Hemlock is uniform, relatively hard. Minimum spiral grain. Fine texture.
- West Coast Hemlock is stable, easy to work. Takes paint smoothly. NO pitch pockets.
- West Coast Hemlock is durable. Not brashy.



Write for "TREE LIFE HEMLOCK," a 20-page booklet on properties and uses. St. Paul & Tacoma Lumber Company, Dept. AR, Tacoma 2, Washington.

Specify with Confidence

TREE LIFE
WEST COAST UPLAND®
HEMLOCK

ANOTHER
FAMOUS
MEMBER OF
THE TREE LIFE
FOREST
PRODUCTS
FAMILY



THE RECORD REPORTS

City Building

(Continued from page 258)

of building construction that may be worth pursuing. This is its potentiality for employment and unemployment. For it is to the construction industry that the nation looks for salvation — which is work — when depression comes. In the '30s it was to the public works segment of that industry that all eyes turned.

In the present era, of course, one should never mention "depression" without giving instant verbal assurance that such a disaster is no longer possible or at least is not to be thought of. But perhaps we should occasionally think of it — in order to avoid it.

Avoiding "The Next Time"

Last time public works was expected to prime the pump and carry the load until private construction and industry could get rolling. But what was done was much too little and far too late. Next time — or in order to avoid a next time — *all* construction must be maintained — and increased if possible. It must maintain its present annual volumes in order to maintain its own employment — let alone provide additional employment.

"Policies for the Control of Public Works" is the title of an article in the October 1953 issue of *The American City* by William Stanley Parker, prominent Boston architect and consultant on public works planning. Mr. Parker advocates Federal public expenditures consciously fluctuating counter-cyclically to offset the fluctuation in private enterprise. For local public works he recommends "a policy of stabilization based upon advance programming of needed projects and the building up of long-term reserves in years of activity, available for the financing of projects when conditions begin to slack off, without adding tax rate burdens just when tax collections are likely to slacken also."

The construction industry has, I venture to suggest, a challenging opportunity to advance both its own interests and the public welfare by studying proposals such as this and by helping to make public construction an increasingly effective factor in the building of finer cities, towns and villages and — in combination with private construction — in the maintenance of a high level of employment, prosperity, and general welfare.

THE MILLER COMPANY

FOR TRUE VALUE IN LIGHTING EQUIPMENT LOOK TO THE MANUFACTURER. You can compare design and test data. But for Continuous Dependability you must rely on the maker. Behind Miller are 110 years' experience — million-dollar production facilities — 1000 combined man years of field lighting engineering. Fluorescent, Incandescent, Mercury fixtures for industry, commerce, schools.

Meriden, Conn. Leaders in lighting since 1844

• CLIP THIS AD TO YOUR LETTERHEAD AND MAIL FOR FULL INFORMATION •

AD TO YOUR LETTERHEAD AND MAIL FOR FULL INFORMATION •

FOR FULL INFORMATION • CLIP THIS AD TO YOUR LETTERHEAD

AND MAIL FOR FULL INFORMATION • CLIP THIS

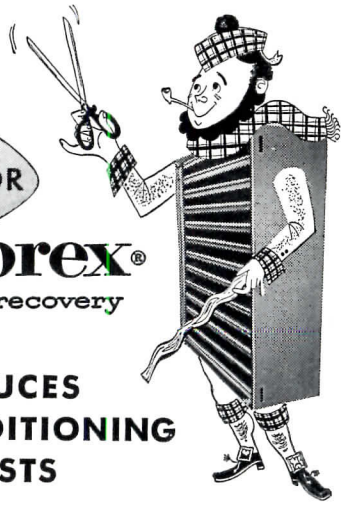

**REDUCES
AIR CONDITIONING
COSTS**

Dorex Air Recovery "manufactures" new air by passing used air through Dorex Activated Carbon, the most powerful adsorbing agent known. More than 6,000 users and 20 years' experience indicate that every \$100 invested in Dorex should return a \$400 saving in the cost of original heating and cooling equipment. In use, every \$1.00 spent for Dorex maintenance should produce a \$4.00 saving in operating costs. Get the full story of Dorex Air Recovery savings today.

CONNOR ENGINEERING CORP. • DANBURY, CONN.

Interior Fire Alarm Systems

coded and non-code types

Complete reliability is the one thing we demand from a fire alarm system. Therefore, when ordering Interior Fire Alarm Systems, be sure to specify equipment (control panels, stations, and fire alarm bells) produced by Signal Engineering & Manufacturing Co., the originators of A-C Fire Alarm Systems.

Both coded and non-code types are available in various arrangements depending on type of building or establishment. Although Interior Fire Alarm Systems are intended primarily for warning occupants of a building, they can be connected into a municipal system.

Engineering representatives in principal cities are available to assist in specifications.

Write for Bulletin FA-7

Wheelock FIRE ALARM SIGNAL ENGINEERING & MFG. CO. LONG BRANCH, NEW JERSEY

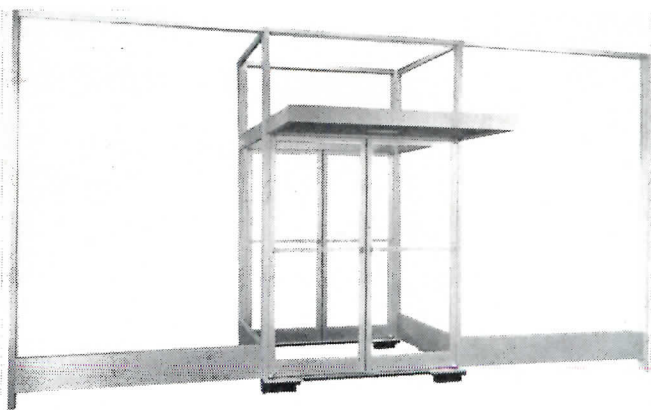

Entrance to General Motors Proving Grounds Building, Detroit, Michigan. Furnished and installed by Fire Doors, Inc., Detroit. Photo shows complete entrance, vestibule doors, sidelights, transoms, canopy and return panels assembled at the factory for final inspection before being disassembled and packed for shipment in six sections.

ALUMILINE

EXTRUDED ALUMILITED ALUMINUM PRODUCTS

Specified by Leading Architects for:

HOSPITALS • SCHOOLS • RELIGIOUS BUILDINGS • BANKS
STORE FRONTS • OFFICE BUILDINGS • INDUSTRIAL PLANTS
HOUSING PROJECTS • SHOPPING CENTERS

- Extruded Aluminum Store Front Construction
- Extruded Aluminum Factory Assembled Entrance Frames
- Narrow and Wide Stile Extruded Aluminum Doors
- Custom Built Extruded Aluminum Windows

Just Off The Press:

TWO Valuable 1954 Catalogs

... for your files

Practical and specific, expressly planned and prepared with your needs in mind, are these two reprints from Sweet's 1954 File. Many new innovations are shown in both catalogs. Use the coupon to request your copies of either or both TODAY. No obligation.

"ALUMILINE"

Store Front Construction

Includes detailed specifications and sectional drawings of Sash, Division Bars, Corner Bars and Reinforcements, Sills, Transom Bars & Adaptors, Glass and Metal Settings, Facia and Awning Hood, and Store Front Construction Details. A very practical and useful working manual.

"EXTRUD-A-LINE" Entrances

Complete, detailed information for quick, convenient reference. Includes scale drawings of typical horizontal and vertical sections for Standard and Wide Stile entrance units, and many photos of outstanding installations.

MANHASSET PUBLIC LIBRARY

Manhasset, L. I.
Alumiline Exterior Entrances and Doors were used in the construction of this recently completed building.

see our catalog in ARCHITECTURAL FILE or write for copy

THE ALUMILINE CORPORATION

DUNNELL LANE PAWTUCKET, R. I.

THE ALUMILINE CORPORATION, Dept. A

Dunnell Lane, Pawtucket, R. I.

Please send us, without obligation, copies of your new 1954 Catalogs, as follows:

- "ALUMILINE" Store Front Construction
- "EXTRUD-A-LINE" Entrances

Firm.....

By.....

Address.....

City.....State.....

when there's more
than one floor
.... think of
Sedgwick

IN COMMERCIAL AND INDUSTRIAL BUILDINGS

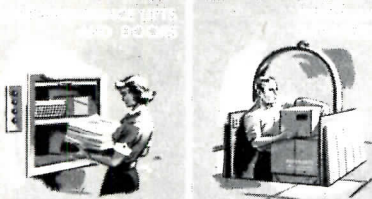

to move loads from floor to floor
and to make better use of space

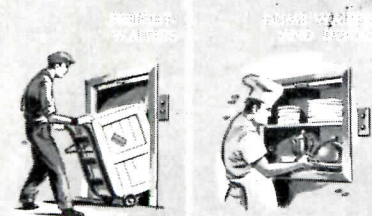

IN RESIDENCES

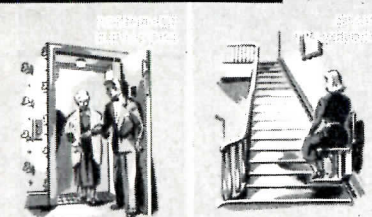

to add one-floor convenience

Sedgwick furnishes safe, modern vertical transportation equipment to fit in with your plans. Quality performance is assured by 60 years of constant improvements and engineering advances. Specified by three generations of architects. For free specification service and engineering recommendations, write:

Sedgwick
MACHINE WORKS

142 W. 15th St., NEW YORK 11, N. Y.

Specialists
in Vertical Transportation Since 1890

THE RECORD REPORTS

(Continued from page 252)

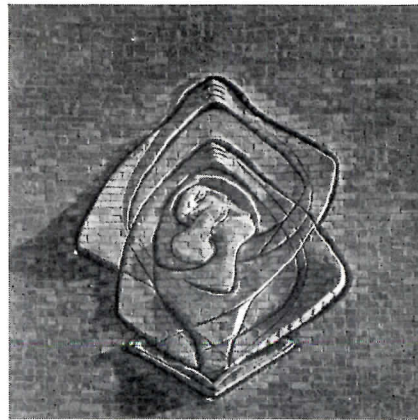

**STUDENT UNION FEATURES
SCULPTURED BRICKWORK**

Sculptor Charles Umlauf has designed for the University Baptist Student Union Building at Austin, Tex., a decorative sculpture of molded brick in what is believed to be the first such use of the material.

The original design was done in clay, from which Mr. Umlauf made a four-piece plaster casting. The mold was then taken to the brick plant, where the clay was extruded and pressed into the casting. Wooden spacers were used to obtain the proper mortar joint. The pieces were then kilned. Mr. Umlauf supervised the laying of the brick and finished off the sculpture with stone cutters.

The \$200,000 building was designed by Carlton Brush, architect, with J. Robert Buffer as associate.



DEPENDABLE

STROMBERG

**COMPLETE CLOCK AND
PROGRAM SYSTEMS for
SCHOOLS • HOSPITALS
PUBLIC BUILDINGS • PLANTS**

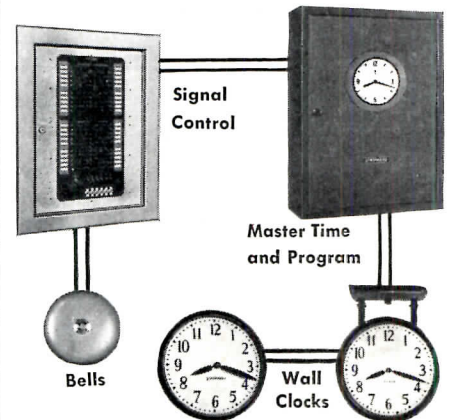

Stromberg time systems maintain the complete accuracy of each unit. They are timed by a synchronous motor Master Unit that has a jewelled spring power emergency reserve. Every clock on the system can be maintained at a correct time even during a power failure. Stromberg time systems include a master control, program unit, signal control panel, bells and buzzers, standard clocks, skeleton dial clocks, tower clocks and time recorders.

for complete information write

STROMBERG
TIME CORPORATION

GT subsidiary of general time corp.
THOMASTON, CONNECTICUT

**USE THIS NEW SAFETY MATERIAL
ALL OVER
YOUR
PLANT**



Work platforms



Flooring

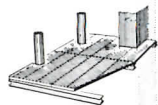

Gutter Covers



Partitions



Safety

GRIP-STRUT

Pat. Pending

NON-SKID—RUGGED—LOW COST

Safety Grip-Strut is a new basic material. All one piece, steel or aluminum, in various sizes and gauges. Sold like lumber, used like lumber and stocked in your storeroom like lumber. Ideal for on-the-job fabricating. Not welded, riveted or expanded. It presents an open space, in a diamond shaped pattern, in excess of 75% of the area for ready access of light and air and gives a positive NON-SKID footing in all directions. Ideal for stair treads, fire escapes, cable trays, work platforms, catwalks, flooring and for original equipment safety treads. Your own mechanics can install it—it's inexpensive, yet permanent and safe.

Write today for new catalog showing loadings and methods of easy application in your plant.

Distributors in all principal cities.

**GRIP-STRUT division
THE GLOBE COMPANY**

Manufacturers since 1914

4020 S. Princeton Ave. • Chicago 9, Ill.



Refrigeration

**Provides Five Services
For Hotel William Penn**

These include air conditioning, cooling drinking water, refrigeration of foods, freezer service, and making ice. This magnificent Pittsburgh hotel has used Frick equipment since 1936, and finds it both efficient and dependable. Three of the four Frick compressors are shown below.

YOUR clients, too, can likely increase their profits with a Frick cooling system engineered to meet their exact needs. Let us submit estimates. Frick Branch Offices and Distributors in principal cities.

See our pages in Sweets Architectural & Industrial Construction Files

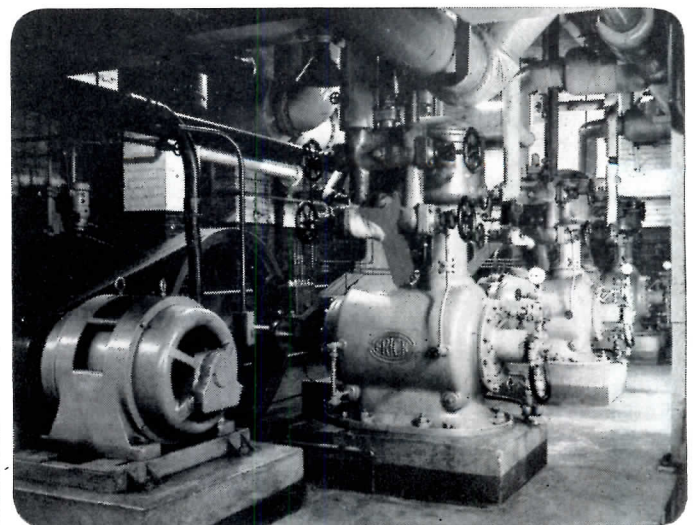

*** Securitee SYSTEMS**
Mechanical Attachments for Erecting Acoustical Tile

See Sweet's Architectural File or write direct for NEW folders giving complete technical data

W. J. HAERTEL & CO.
832 WEST EASTMAN STREET, CHICAGO 22, ILLINOIS
U.S. Pat. Off.

Specify this **EXTRA**
Margin of Safety
and Durability
for Modern Stairs

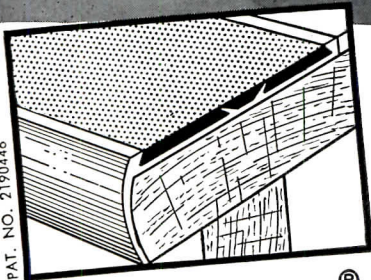

TUFF-TRED[®]

SAFETY STAIR NOSING

In all types of buildings . . . wherever there are stairs . . . you can eliminate slipping hazards, protect and preserve architectural beauty with TUFF-TRED Safety Stair Nosings. Made of polished extruded aluminum. Anti-slip, with semi-resilient filler containing better than 60% abrasive grains. May be used with any resilient floor covering 1/8" thick, or over. Standard length 12 feet; colors—tile red, brown, gray and black. Investigate TUFF-TRED and you'll understand why this stair nosing is used so extensively . . . for the extra margin of safety and durability so important today. *A few choice distributorships and dealerships are available. Write, wire or 'phone . . .*

GOODLOE E. MOORE

INCORPORATED

DANVILLE, ILLINOIS

In Canada: W. D. ELMSLIE, Ltd.

409 Notre Dame St., West, Montreal 11, Quebec

REQUIRED READING

(Continued from page 48)

technical virtuosity of our times. To dismiss these lightly is to ignore the guts, which must be healthy for the skin to be comely.

One more criticism; what of the dispersed industries which dot such a state as Mississippi and introduce the problems of the mechanical age into, not an urban, but a rural environment? What happens when the entire countryside becomes a factory-scape? To a traveler in the U. S. A. that becomes an important trend; the expanding cities, true, are another; but can we consider the one only? Business economics, military necessity, and rapid personal transportation and communication are rapidly wiping out the differences which used to distinguish the bucolic and the urban.

COLEAN (Continued from page 46)

scurry off in all directions, knocking buildings down, pouring miles of concrete from here to back again, creating new slums, raising new wind-mills. . . . A clear objective means a clear notion about how we want to live and, perhaps, with the H-bomb around, how we want to die."

There are, of course, many things said which can be argued differently in detail. For example, Colean makes much of metropolitan political integration, and cites the consolidation of New York's five boroughs as the outstanding example. One wonders, however, how far such a process should go: Yonkers and Mt. Vernon are contiguous and indistinguishable on the Westchester side, Jersey City, Hoboken, Bayonne are no different than Queens. The areas between these and White Plains, Newark, are filling up. Where does one stop? And why is the remedy to the evil of gigantism, which is what one wishes to escape, with its attendant municipal corruption and over crowded schools, greater gigantism, greater opportunity for corruption and worse schools? Metropolitan area-wide planning and control is undoubtedly needed, but not at the price of being overtaken by Big City Government as it now exists.

Colean's greatest omission is his failure to say a word about the esthetics of urban renewal. This is odd, for his early F.H.A. pamphlet "Modern Design," Technical Bulletin No. 2, was the only intelligent architectural piece ever got-

(Continued on page 274)



**MORE THAN A CENTURY
OF EXPERIENCE**

Is A Capsule Description Of
NATHAN STRAUS-DUPARQUET INC.

To Architects we offer more than 100 years of experience in designing . . . fabricating . . . installing food preparation and service equipment for every type of commercial, industrial and institutional feeding operation.

. . . Decorating and furnishing public and private spaces in hotels, restaurants, hospitals, schools, industrial and commercial buildings and institutions.

If you are planning new installations or renovations . . . we respectfully request that you take advantage of our experience . . . we welcome your inquiries . . . a completely integrated organization is at your service!

NATHAN STRAUS-DUPARQUET INC.

33 EAST 17th STREET
NEW YORK 3, N. Y.

Affiliated with these Firms

In Boston, Mass.
Jones, McDuffee & Stratton Corp.
640 Commonwealth Avenue

In Chicago, Illinois
Albert Pick Co., Inc.
2159 W. Pershing Rd.

In Miami, Florida
The Maxwell Company, Inc.
1035 N. Miami Avenue

Grilles—For That

*Distinctive
Decor*

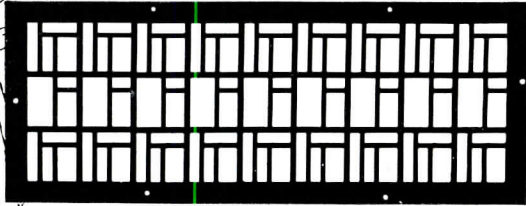

Just as eye-appealing as they are functional, Hendrick Perforated Metal Grilles will greatly enhance the beauty of any decorative motif.

They provide more-than-ample open area for the free passage of air, and are available in a wide variety of designs to best set off your decor. And they're easy to install—always lie flat because of a special flattening operation in their manufacture. For more complete details write Hendrick today!



Hendrick

MANUFACTURING COMPANY

38 DUNDAFF ST., CARBONDALE, PA. • Sales Offices in Principle Cities
Perforated Metal • Perforated Metal Screens • Wedge-Slot Screens • Archi-
tectura l Grilles • Mitco Open Steel Flooring • Shur-Site Treads • Armorgrids

**this handy
WORKING TOOL
FREE!**



Kayline's 74-page Catalog No. 53 is a handy working tool for all commercial and industrial lighting requirements. Gives information and charts on footcandles of light, light patterns, installation suggestions and other needed data. Send for it today!

THE KAYLINE COMPANY
2480 East 22nd Street
Cleveland 15, Ohio
the one source lighting line

NOTICE TO ARCHITECTS

You may have a great deal of lighting data in your files, but you may be missing the "best help" you could possibly have on modern lighting if you do not have a copy of Kayline Catalog No. 53 for yourself and your specification writer. Send request on postcard or attach this advertisement to your letterhead.

WARM DRY FLOORS for ALL Basementless Construction



NOW...ZONOLITE®
offers the built-in
benefits of
**Insulation, Fire-
safety, Light Weight
and Permanence...**

IN TWO GREAT CONCRETE PRODUCTS

ZONOLITE® VERMICULITE CONCRETE

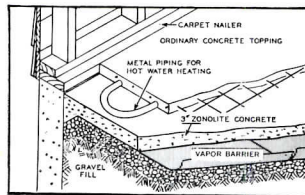

ZONOLITE Vermiculite Concrete used under radiant heat pipes for more efficient operation and control.

Lightweight, insulating and permanent, ZONOLITE Vermiculite Concrete is ideal for roof decks, roof insulation, cavity-wall fill and insulating floors on the ground. Perfectly suited as a base for radiant heat systems. Where an exposed concrete floor is desired, ZONOLITE with a sand-concrete topping provides high insulating efficiency, cuts heat loss.

ZONOLITE® SAND CONCRETE

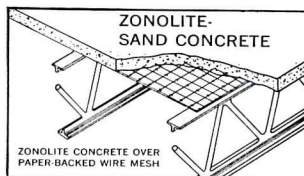

ZONOLITE Vermiculite Sand Concrete is ideal for use on one-pour floors on grade, lightweight upper story floors.

Has resilience approaching wood floors! Use as fill over structural floors, for floor slabs over closely spaced joints, or for floor slabs on the ground. Has 4½ times the insulating value of ordinary concrete—½ the weight. Fireproof and permanent. ZONOLITE Vermiculite Sand Concrete is ideal as a base for tile, linoleum, terrazzo or carpeting—needs no topping.

ZONOLITE COMPANY

135 S. LaSalle St., Chicago 3, Ill.

SEND FOR FREE BOOKLET!



Zonolite Company, Dept. AR-14
135 S. LaSalle St., Chicago 3, Ill.

Please rush FREE Booklet CA-4, "Floor Slabs and Floor Fill," with complete details on ZONOLITE Vermiculite Concrete and new ZONOLITE Sand Concrete.

Name.....
Firm.....
Address.....
City.....Zone.....State.....
 Architect Contractor Other.....

school
architects:
regardless
of how much
more you
might spend,
you cannot
buy a more
practical
or a more
dependable
school sound
system than
a **Bogen**

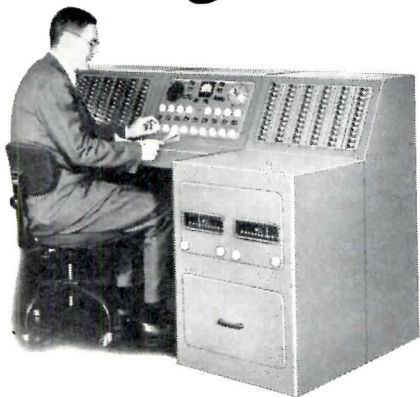

A system for every budget, functionally designed according to the recommendations of the U. S. Office of Education, and built by the country's largest manufacturer of sound systems.

David Bogen Co., Inc.
29 Ninth Ave., N. Y. 14.

see catalog ^{31a}_{Bo}
in Sweet's File

REQUIRED READING

(Continued from page 270)

ten out by that organization. It would have completed "Renewing Our Cities" had he made it clear that physical renewal is not enough, that to the others to re-establish a city in Time and Space must be joined the fifth dimension of Commodity, Firmness and Delight.

NEW SMALL HOUSES

The New Small House. By F. R. S. Yorke and Penelope Whiting. *The Architectural Press* (London, England) 1953. 7 by 9¼ in. 144 pp. illus. 25s net.

The postwar period has been one of rapid building the world over. The major problem has been housing the low income groups of bombed-out areas. This book, containing a comprehensive group of illustrations and photographs of small houses, housing developments, and even a trailer and a house boat, deals mostly with this problem as it affects England.

F. R. S. Yorke, an architect working on one of the most important of the New Town developments, Harlow, finds in his survey no clear school of thought in postwar small house architecture — is disappointed to find such a lack of ad-

venture. "Not very many of the houses in this book have an appearance that expresses a new way of living, or the use of new materials . . ."

On the brighter side — "The overall standard of house planning is a much better one than was ever reached by the local authority . . . before the war."

The New Small Houses is an interesting study that deals quite frankly with the problems that British architects in particular must face — scarcity of materials and government control. "It is a pity that local authority housing sometimes suffers because the amount of original thought is scaled down to range with the reduced fees permitted by the Ministry of Housing and local government and it is clear that a number of architects must give a great deal of thought to house design simply for the enjoyment they get out of it." — M. Blake

REMODELING OLD ROOMS

Old Rooms for New Living. By Narcissa Chamberlain. *Hastings House Publishers, Inc.* (41 E. 50 St. New York, N. Y.) 1953. 7 by 10 in. 130 pp., illus. \$4.50.

This book, generously illustrated with fine photographs by Samuel Chamberlain, shows how old rooms of Colonial vintage can be adapted for gracious living in the twentieth century.

The BEAUTY of Grinnell *Flush- Type*

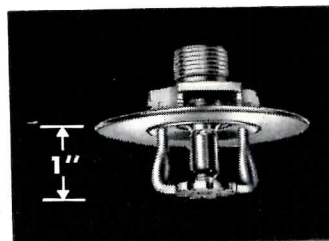

Ceiling Sprinklers

By planning your fire protection in the blueprint stage, you not only get the most efficient protection, but a system that *harmonizes* with interiors.

Because the Grinnell Ceiling Sprinkler protrudes only 1 inch below the ceiling and is available in a variety of finishes and colors, it is the ideal sprinkler for offices, shops, stores, restaurants, lounges, country clubs. It gives reliable, unobtrusive fire protection.

Grinnell Company, Inc., Providence, Rhode Island — manufacturing, engineering and installation of automatic sprinklers since 1878.



GRINNELL
FIRE PROTECTION SYSTEMS

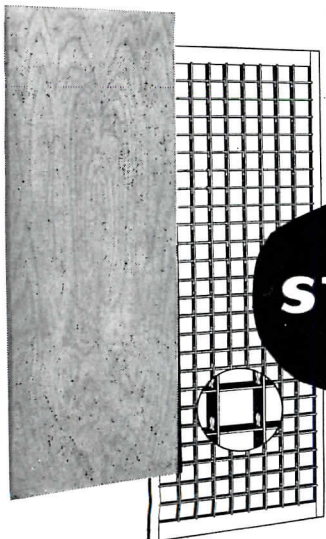

Beauty
Outside

LASTING
STRENGTH
INSIDE

Beautiful on the outside—available in carefully selected veneers—Curtis New Londoner hollow-core flush doors are as durable as they are beautiful. Their patented, locked-in all-wood core assures lifetime dimensional stability—no “floating” units to get out of place. Also available—Curtis American solid-core flush doors for exterior and institutional use. For complete information write

CURTIS
NEW LONDONER
HOLLOW-CORE
FLUSH DOORS

CURTIS COMPANIES
SERVICE BUREAU
200 Curtis Building AR-1
Clinton, Iowa

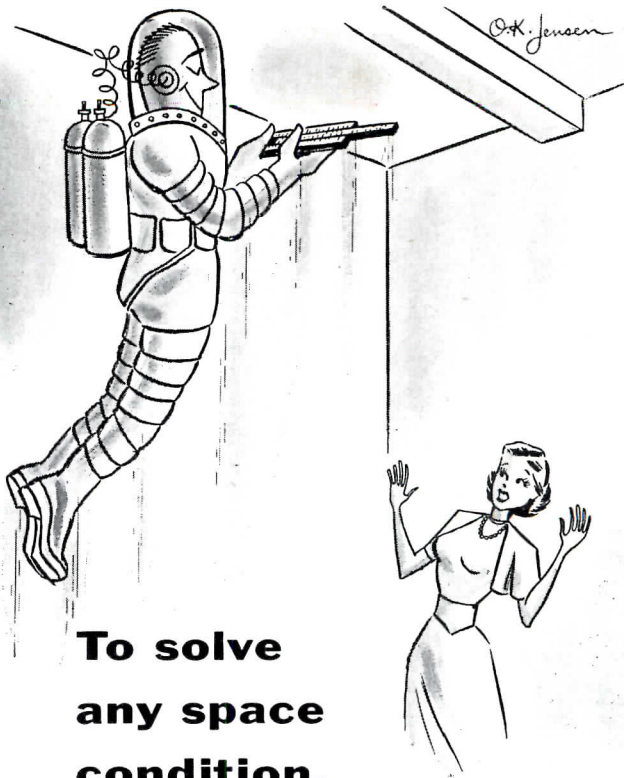

To solve
any space
condition,
specify

AGTAIR

For correct air distribution to suit any space condition, AGITAIR square and rectangular diffusers have no equal. Custom-designed with built-in diffusing vanes, in a wide variety of louver patterns, they provide blows in 1, 2, 3 or 4 directions without use of blank-offs. AGITAIR diffusers need not be centrally located in the area to be served.

Advantages of AGITAIR'S exclusive air pattern control feature are greater design freedom for architects and engineers, certified 100% draftless air distribution from any ceiling or sidewall location, maximum economy in duct runs.

New 34-page Type R Catalog reveals how correct air distribution is simplified by AGITAIR. Contact your local AGITAIR representative, or write us direct for your free copy.



AIR DEVICES INC.
185 Madison Avenue, New York 16, N. Y.

AIR DIFFUSERS • FILTERS • EXHAUSTERS

Don't Hide the Beauty of
REDWOOD
Specify "the Original"
RESIN FREE
LIQUID RAWHIDE
PAINTS, STAINS AND CLEAR FINISHES FOR REDWOOD

Inhance the natural rich redwood color with our Clear Finish or hold the natural kiln-dry redwood color with our Color-Fix No. 9. Inside or Outdoors.

Actual wood panels and specifications sent FREE when requested on your Firm letterhead.

Linseed Oil Products Co.
1112A South Fremont Avenue
Alhambra, California

Resin-Free
BEHR PROCESS
Marine Spar

Resin-Free
BEHR PROCESS
Redwood Paint

Resin-Free
BEHR PROCESS
Blond

Resin-Free
BEHR PROCESS
Color-Fix #9

Resin-Free
BEHR PROCESS
White and Pastel Color Base #7

Resin-Free
BEHR PROCESS
Redwood Paint Low Luster

Resin-Free
BEHR PROCESS
Green Color-Preservative #8

Resin-Free
BEHR PROCESS
Quick Dry Linoleum Coating

Resin-Free
BEHR PROCESS
Redwood Paint-Gloss White

Resin-Free
BEHR PROCESS
Gray Color-Preservative #6

Resin-Free
BEHR PROCESS
Quick Dry Linoleum Coating

Resin-Free
BEHR PROCESS
Color-Fix #9

Resin-Free
BEHR PROCESS
Redwood Finish

Resin-Free
BEHR PROCESS
Redwood Color Wood Stain & Sealer #3

Charts by Dodge Statistical Research Service

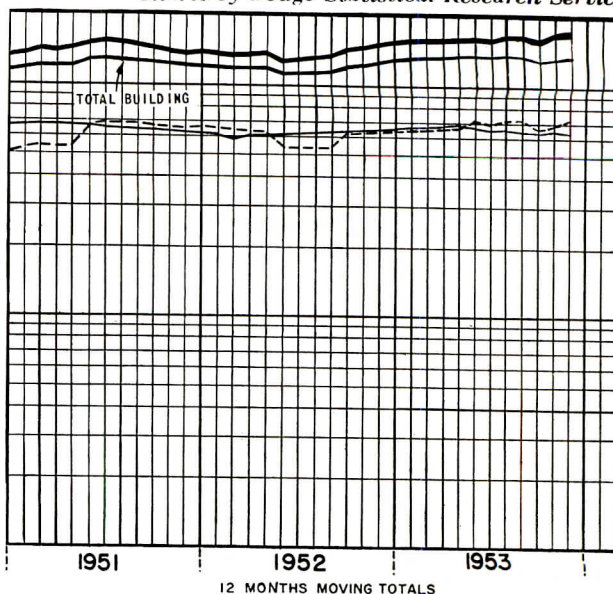
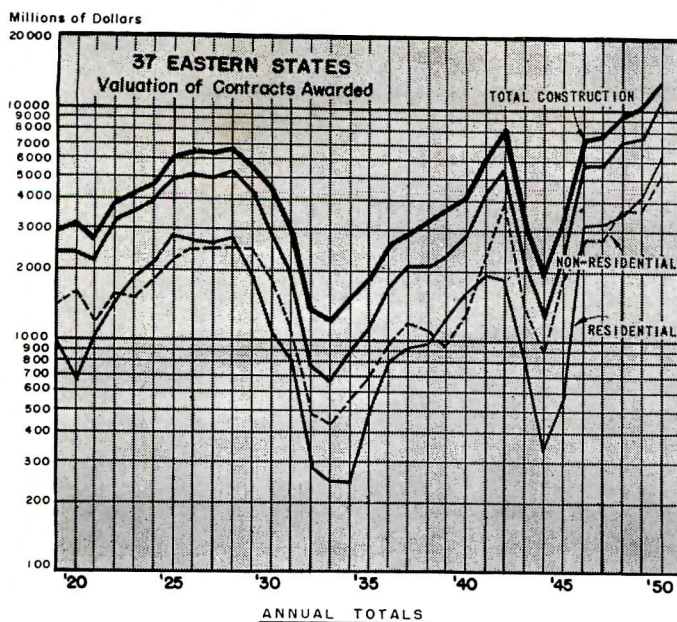

RECORD CONTRACT LEVELS MAINTAINED

Construction activity in the closing months of 1953 was continuing at record highs. November contract awards as reported by F. W. Dodge Corporation showed an increase of 12 per cent over November 1952, and total contracts for the first eleven months exceeded 1952 by five per cent.

Non-residential building work continued active, showing a 33 per cent increase over November 1952. Leaders in this category were:

	November '52	November '53
Social & Recreational Buildings		
Buildings	\$10,949,000	\$24,214,000
Commercial Buildings	84,491,000	101,392,000
Manufacturing Buildings	117,431,000	232,218,000
Educational & Science Buildings	116,936,000	140,283,000

Residential construction in November declined slightly from 1952, led by a drop in apartment contracts. However, the total valuation of residential work for the first eleven months was only three per cent under 1952.

Total Dodge construction contracts for the first eleven months of 1953 stood at \$16,143,699,000 as compared with \$15,307,552,000 in 1952.

NONRESIDENTIAL BUILDING (37 EASTERN STATES)

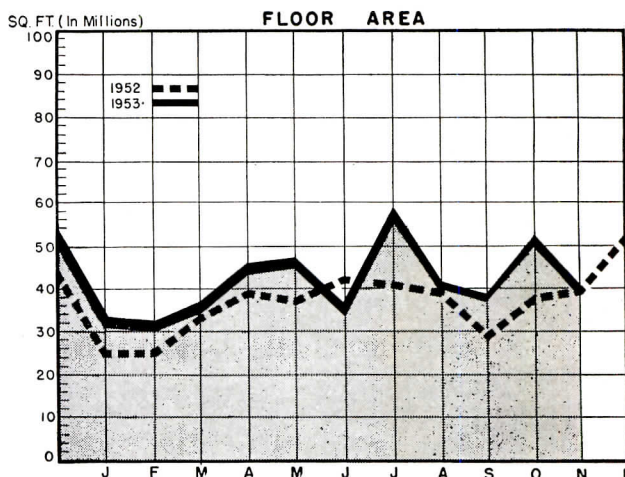

RESIDENTIAL BUILDING (37 EASTERN STATES)

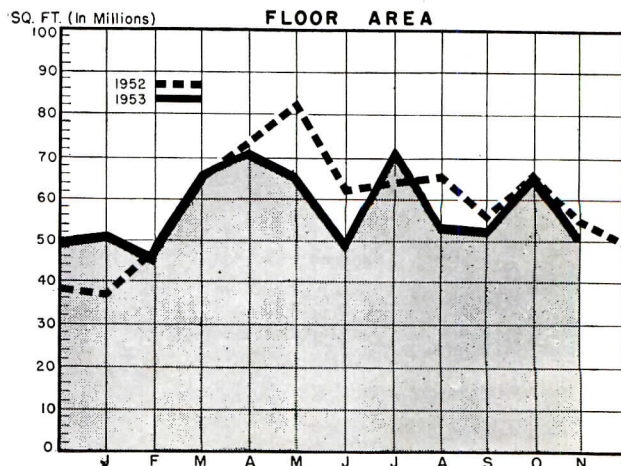

SOCIAL & RECREATIONAL BUILDING* 1947-1953							
F. W. Dodge Contracts Awarded — Millions of Dollars (37 Eastern States)							
Year	Annual Total	Monthly Average	Year	Annual Total	Monthly Average		
1947	122.0	10.2	1950	261.3	21.8		
1948	232.4	19.4	1951	136.6	11.4		
1949	222.0	18.5	1952	153.4	12.8		
1952			1953				
Jan.	8.4	July	16.5	Jan.	10.6	July	29.6
Feb.	5.9	Aug.	11.6	Feb.	13.4	Aug.	20.0
Mar.	7.6	Sept.	12.3	Mar.	16.2	Sept.	17.2
Apr.	10.5	Oct.	15.8	Apr.	24.9	Oct.	19.9
May	17.1	Nov.	10.9	May	18.5	Nov.	24.2
June	20.4	Dec.	16.3	June	13.3	11 mos.	207.9

* See Building Types Study No. 206, pp 146 to 168