

## TOP SPEED ON WORLD'S GREATEST HOUSING JOB

•  
**'INCOR' SAVES TIME, CUTS COSTS, ON  
NEW YORK CITY HOUSING AUTHORITY'S  
SOUTH BEACH HOUSES**

**NEW YORK CITY HOUSING AUTHORITY:  
SOUTH BEACH HOUSES, South Beach, S.I., N.Y.**

Architect: **HENRY V. MURPHY, Brooklyn, N.Y.**

Structural Engineer: **FRED N. SEVERUD, New York City**

Contractor for Superstructure: **CAYE CONSTRUCTION COMPANY, INC., Brooklyn, N.Y.**

'Incor' Ready-Mix Concrete: **ROAD MATERIAL CORPORATION, Greenridge, S.I.**



**W**ITH 34,000 families already living in 31 apartment projects . . . with 21,000 apartments now under construction . . . and with 11 projects now in the planning stage, the New York City Housing Authority is setting the pace in a \$750,000,000 city-wide home-building program. Sound planning and efficient administration have wrought something approaching a miracle under our very eyes, converting slum areas into healthful, modern housing and raising the standards of life and living throughout the City.

This greatest housing program of all time goes ahead at top speed, winter and summer. To maintain schedules through the cold-weather months, the Contractor on South Beach Houses, Staten Island, switched to 'Incor' 24-Hour Cement for superstructure concrete. Results: (1) Forms stripped 3 days sooner . . . faster form re-use, fewer forms needed for high-speed concreting; (2) 60% saving on heat-protection expense . . . a big economy factor with coke at about \$25. a ton!

Any season, any type of job, dependable 'Incor'\* high early strength assures maximum job speed at minimum cost.

\*Reg. U. S. Pat. Off.

# LONE STAR CEMENT CORPORATION

Offices: ALBANY • BETHLEHEM, PA. • BIRMINGHAM • BOSTON • CHICAGO • DALLAS • HOUSTON • INDIANAPOLIS • JACKSON, MISS. • KANSAS CITY, MO. • NEW ORLEANS • NEW YORK • NORFOLK • PHILADELPHIA • ST. LOUIS • WASHINGTON, D. C.

LONE STAR CEMENT, WITH ITS SUBSIDIARIES, IS ONE OF THE WORLD'S LARGEST CEMENT PRODUCERS: 15 MODERN MILLS, 27,000,000 BARRELS ANNUAL CAPACITY

*To Complement*

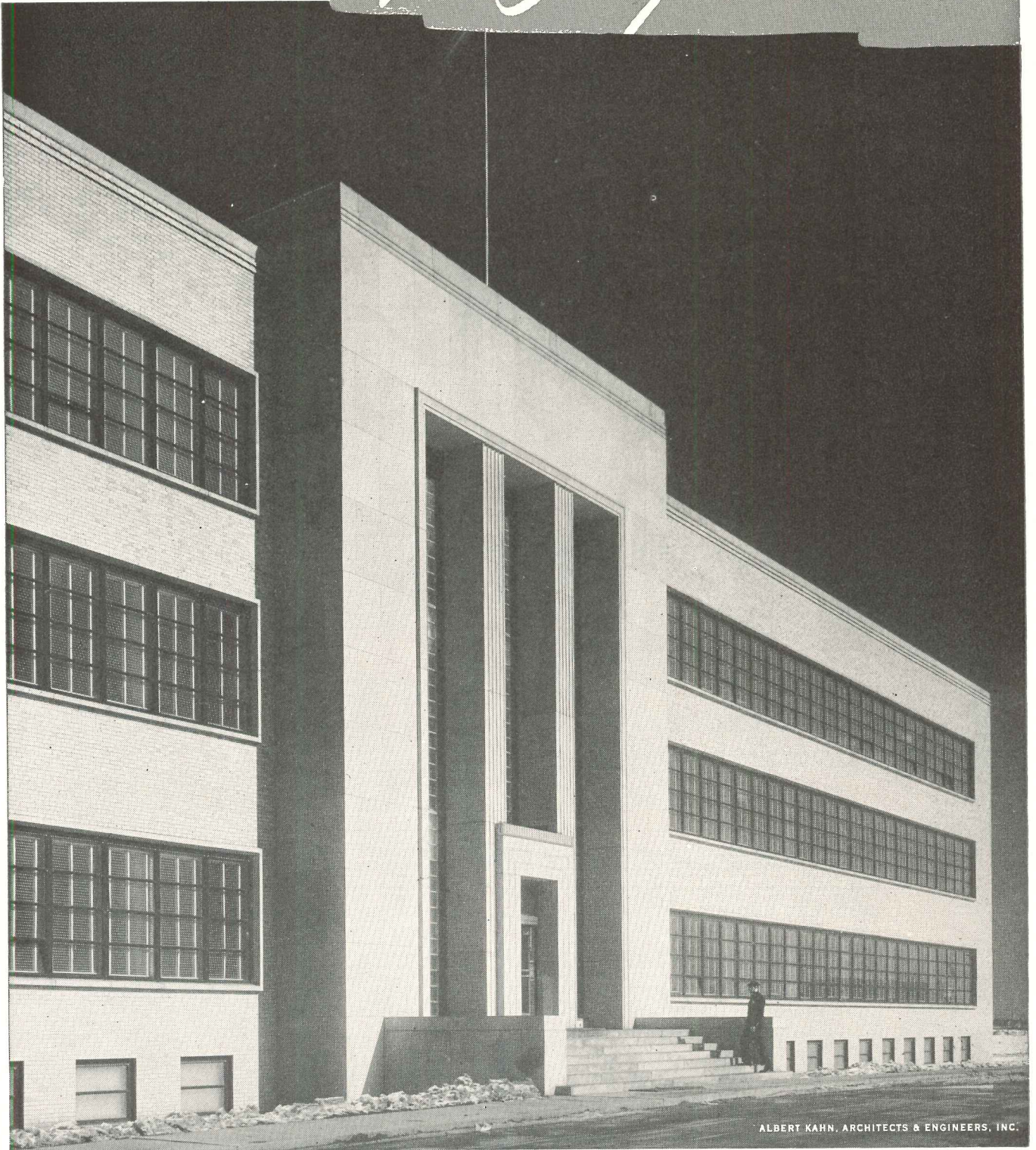

ALBERT KAHN, ARCHITECTS & ENGINEERS, INC.

*In construction products* **CECO ENGINEERING**

*a Monument...*

## CECO Architectural Projected Windows

In keeping with architectural design, monumental buildings need windows that complement their structural magnificence . . . windows designed architecturally with an eye to good appearance. Ceco's Architectural Projected Window is just such a window. From every angle, here is outstanding beauty . . . complete utility. In Ceco's Architectural Projected Window, the sections are designed for maximum strength—the arrangement of glass lights makes for maximum beauty. Consider these features:

1. The frame section is  $1\frac{3}{8}$ " deep. The ventilator section is  $1\frac{1}{2}$ " deep. The extra  $\frac{1}{8}$ " added to the ventilator depth provides the strength so necessary for proper window performance.
2. The frame and ventilators are welded at all four corners.
3. Standard hardware is solid bronze.
4. Easy to screen . . . a great convenience in public buildings, schools, and commercial and industrial buildings.

Yes, from every angle, here's a handsome window with every utility. So, specify Ceco Architectural Projected Windows, for no matter what the architectural design, Ceco has the right window for you.

### CECO STEEL PRODUCTS CORPORATION

General Offices: 5601 West 26th Street, Chicago 50, Illinois  
Offices, warehouses and fabricating plants in principal cities

**CECO  
STEEL**®

*makes the big difference*

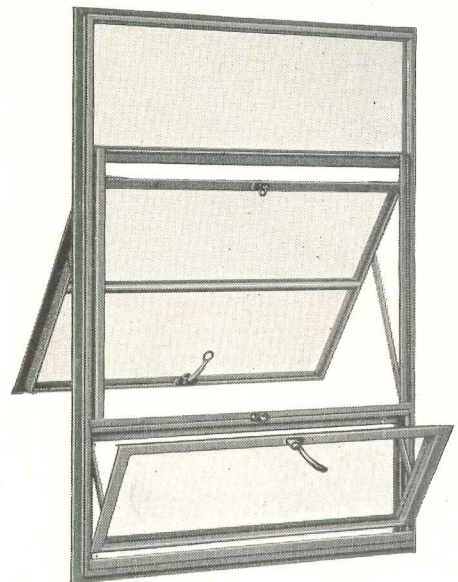

Ceco Architectural Windows are constructed of hot rolled sections, bonderized and especially designed to provide rigidity and good weathering performance. Suitable for public, commercial and industrial buildings . . . designed to provide weather protection when open . . . adaptable to screening with Ceco standard screens, since each ventilating sash projects on only one side of window.

#### Partial List of Ceco Products

METAL RESIDENCE CASEMENTS • INDUSTRIAL WINDOWS AND DOORS • METAL FRAME SCREENS • ALUMINUM FRAME STORM WINDOWS • ALUMINUM COMBINATION STORM WINDOW AND SCREEN UNITS • METAL LATH AND ACCESSORIES • STEELFORMS • REINFORCING BARS STEEL JOISTS AND ROOF DECK • HIGHWAY PRODUCTS



**these STEAM LINES**  
 pass their tests with the help of  
**BYERS WROUGHT IRON PIPE**

Flanked by two large new dormitories, (one illustrated above), Texas Technological College sprawls over hundreds of landscaped acres. Heat is supplied to the structures from a central plant through an extensive underground distribution system. To extend the life of the installation, and protect against excessive maintenance, the designers made extensive use of Byers Wrought Iron pipe. Sizes ranging from one-half inch up to 12-inches were installed for steam supply and return lines and fire lines in the dormitory buildings, and for supply and return lines in the pipe tunnels.

Proper selection of pipe for use in underground heat distribution systems is always important, for the tunnels generally create severe corrosive conditions—particularly when operation is intermittent. While pipes are cold, some moisture accumulates in the tunnel. A

film of water forms on the pipe—atmospheric gases dissolve in the water—and corrosive attack occurs. When heat is again applied, a hot, humid atmosphere, favorable to scaling is created. Unless the pipe material can resist these conditions, trouble will follow.

Service records provide plenty of convincing evidence of wrought iron's corrosion resistance. In one typical large installation, the chief engineer reported the lines were "still in perfect condition," after 14 years. Results from earlier installations indicate that the period of wrought iron's trouble-free service had only begun.

The unusual character of wrought iron protects it. Tiny fibers of glass-like silicate slag, threaded through the body of high-purity iron, halt and disperse attack, and so discourage local pitting. The fibers also anchor the initial protective scale, which shields the underlying metal.

You will find helpful information in our bulletin, **WROUGHT IRON FOR UNDERGROUND SERVICES**. Ask for a copy.

A. M. Byers Co., Pittsburgh, Pa. Established 1864. Boston, New York, Philadelphia, Washington, Atlanta, Chicago, St. Louis, Houston, Salt Lake City, Seattle, San Francisco. Export Division: New York, N. Y.

CORROSION COSTS YOU MORE THAN WROUGHT IRON

**BYERS**  
 GENUINE WROUGHT IRON  
 TUBULAR AND HOT ROLLED PRODUCTS  
 ELECTRIC FURNACE QUALITY ALLOY AND STAINLESS STEEL PRODUCTS

**ARCHITECTURAL  
RECORD**



Copyright 1949 by F. W. DODGE CORPORATION, with all rights reserved • Publishing Director, Magazine Division, H. Judd Payne • **EDITORS:** Editor-in-Chief: Kenneth Kingsley Stowell, A.I.A.; Managing Editor, Emerson Goble; Associate Editors, Robert E. Fischer, Florence A. van Wyck; Washington News, Ernest Mickel; Contributing Editor, Arthur McK. Stires; Western Editor, Elisabeth Kendall Thompson; Special Editorial Representative, Western Section, William C. Rodd; Associate in South America, Edmund J. Whiting, A.I.A.; Editorial Assistants, Jeanne Davern, Cornelia Reagan • **ART DEPARTMENT:** Myron S. Hall, 3rd, Director; Frances Torbert, Assistant; Sigman-Ward, Drafting • **CONSULTANTS:** Industry Relations Consultant, Thomas S. Holden; Statistical Consultant, Clyde Shute; Building Economics Consultant, Norbert Brown; Field Research Consultant, Clifford Dunnels, Jr.

Architectural Record (combined with American Architect and Architectural) is published monthly by F. W. Dodge Corporation, 10 Ferry St., Concord, N. H., with Editorial and Executive Offices at 119 West 40th Street, New York, N. Y. Western Editorial Office, 2813 Channing Way, Berkeley, Calif. Thomas S. Holden, Pres.; Howard J. Barringer, Vice-Pres. and Treas.; Irving W. Hadsell, Vice-Pres.; Chauncey L. Williams, Vice-Pres.; Sanford D. Stockton, Jr., Secy.; Walter F. De Saix, Asst. Treas.; Edwin H. Freed, Asst. Treas. Member Audit Bureau of Circulation and Associated Business Papers, Inc. Architectural Record is indexed in Reader's Guide, Art Index, Industrial Arts Index and Engineering Index. Subscription rates: United States and Possessions, Canada, Cuba, Mexico, Central and South America, and Spain, \$4.50 the year, \$7.50 for two years, \$9 for three years; elsewhere, \$6.50 the year, \$11.50 for two years, \$15 for three years. Single copy, \$1. Circulation Manager: Marshall T. Ginn. Every effort will be made to return material submitted for possible publication (if accompanied by stamped, addressed envelope), but the editors and the corporation will not be responsible for loss or damage. Other Dodge Services: Real Estate Record & Builders' Guide, Sweet's Files, Home Owners' Catalogs, Dodge Reports & Dodge Statistical Research Service.

<b>DESIGNERS EXTRAORDINARY</b> . . . . .	85
An Editorial . . . by Kenneth K. Stowell	
<b>LAMONT LIBRARY, HARVARD UNIVERSITY</b> . . . . .	86
Coolidge, Shepley, Bulfinch and Abbott, Architects and Engineers	
<b>DESIGNING WHAT COMES NATURALLY</b> . . . . .	96
"Tamalpais House," north of San Francisco, Calif. Henry Hill, Architect. Eckbo, Royston and Williams, Landscape Architects	
<b>ARCHITECTS DESIGN FOR INDUSTRY</b> . . . . .	102
A Current Visual Report on Industrial Design by Architects	
<b>REBUILDING THE WHITE HOUSE</b> . . . . .	116
By Frederick Gutheim	
<b>BUILDING TYPES STUDY NO. 150 . . . RADIO AND TELEVISION BUILDINGS</b> . . . . .	120
<b>DESIGN OF TELEVISION STATIONS</b> . . . . .	123
By J. P. Allinson	
<b>THE TELEVISION PRODUCING PLANT</b> . . . . .	133
By Elwell	
<b>PROJECTS</b>	
Station WBZ, Boston, Mass. Architectural Department, Westinghouse Electric and Manufacturing Company, Architects. . . . .	134
Experimental Television Station for Teaching, Sands Point, L. I., N. Y. Office of Naval Research, United States Navy, Architects. . . . .	136
Station WICU, Erie, Pa. Nelson and Goldberg, Architects. . . . .	138
Station KHJ, Hollywood, Calif. Claude Beelman, Architect; Herman Spackler, Associate. . . . .	139
Station WHAM, Rochester, N. Y. Kaelber and Waasdorp, Architects. . . . .	140
Station KWKC, Abilene, Tex. Hughes and Olds, Architects. . . . .	141
<b>ARCHITECTURAL ENGINEERING . . . . .</b> Technical News and Research . . . . .	142
<b>PRECAST SYSTEM DEVELOPED FOR LOW-COST DORMITORIES</b> . . . . .	142
McKim, Mead and White Mix Precast and Poured-in-Place Concrete to Keep Costs Down	
<b>METHODS FOR GLARE-FREE LIGHTING STUDIED BY M. I. T.</b> . . . . .	145
By H. L. Beckwith, C. M. F. Peterson, and Parry Moon	
<b>PRODUCTS . . . . .</b> for Better Building . . . . .	148
<b>TIME-SAVER STANDARDS</b> . . . . .	151
Cabinetwork Details . . . . Continued From May Issue	
<b>MANUFACTURERS' LITERATURE</b> . . . . .	154
<b>THE RECORD REPORTS . . . . .</b> News from the Field . . . . .	7
<b>LETTERS TO THE EDITOR</b> . . . . .	24
<b>CONSTRUCTION COST INDEXES</b> . . . . .	26
<b>REQUIRED READING</b> . . . . .	28
<b>NEWS FROM CANADA . . . . .</b> By John Caulfield Smith . . . . .	10
<b>EMPLOYMENT OPPORTUNITIES</b> . . . . .	234
<b>INDEX TO ADVERTISEMENTS</b> . . . . .	248
<b>SEMI-ANNUAL INDEX</b> . . . . .	251
<b>COVER:</b> A Reading Room, Lamont Library, Harvard University. Coolidge, Shepley, Bulfinch and Abbott, Architects. Paul Davis Photograph	

# Fine Flush Valves for Fine Buildings

For complete information on Watrous Flush Valves see your Sweet's Catalog File.

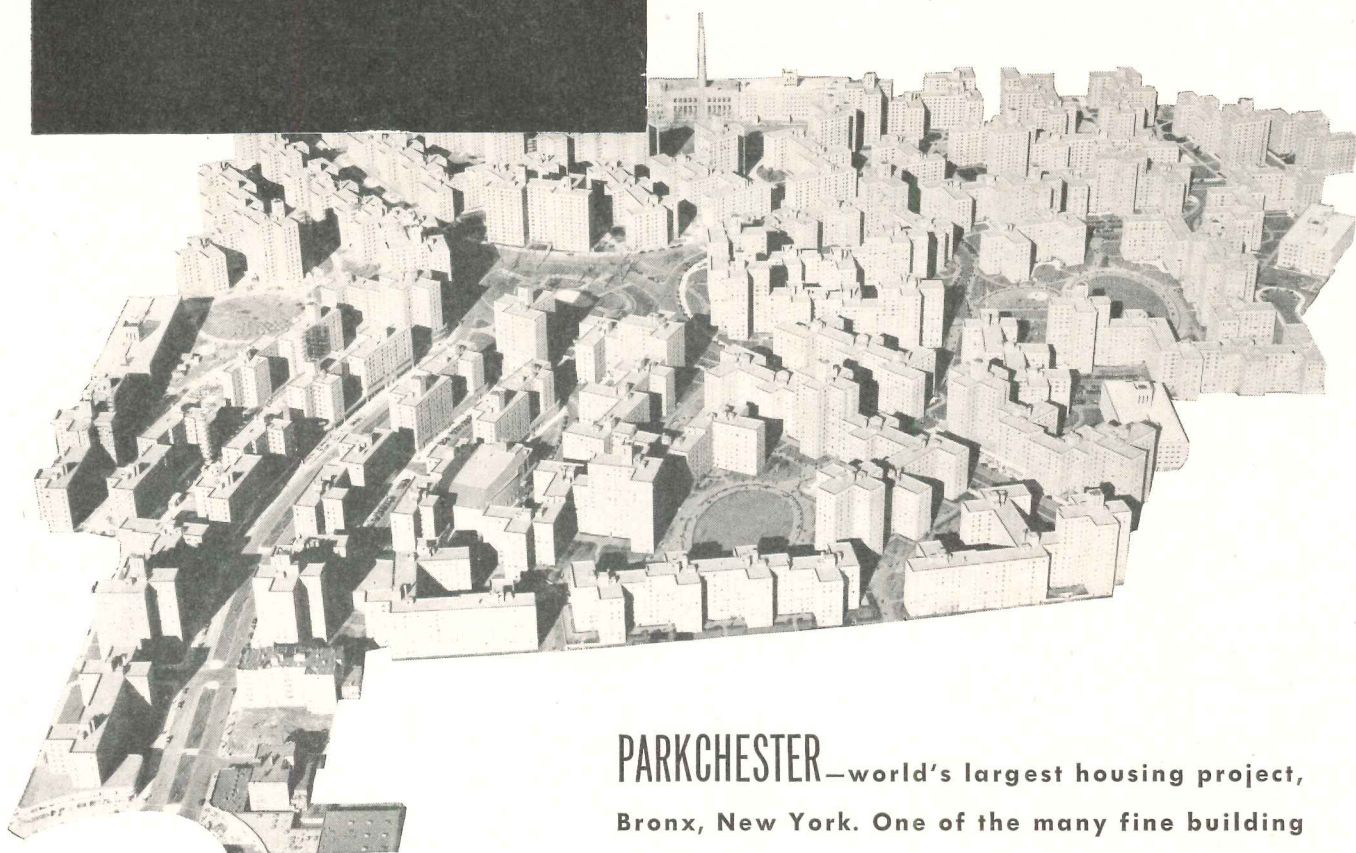

**PARKCHESTER**—world's largest housing project,  
Bronx, New York. One of the many fine building  
projects equipped with Watrous Flush Valves.

**SHREVE, LAMB & HARMON ASSOCIATES**

Architects

**J. L. MURPHY, INC.**

Plumbing Contractors

**Watrous**



**ADJUSTABLE FLUSH VALVES**  
BOTH DIAPHRAGM AND PISTON TYPES

**THE IMPERIAL BRASS MANUFACTURING COMPANY**

1240 W. Harrison Street, Chicago 7, Illinois

# THE RECORD REPORTS

## Senate-Approved Housing Bill Causes Expected Turmoil in House; Party Cleavages Accentuated In Split Over Economy in Government Spending

Overwhelming Senate approval of the bill S. 1070 once again projected the final showdown on a broadened national housing policy into the House of Representatives. Advocates of the Administration's comprehensive housing bill of 1949 discovered they had to compromise but little to secure Senate passage. But this was an old and familiar story — the third time in four years that Senators had left it to their colleagues in the House to make the final determination.

But the circumstances for handling the legislation in the lower chamber had changed this year in one significant respect. It would be impossible for the Rules Committee to keep the measure away from floor consideration as it had done in the past. It turned out that the real fight would be on the floor of the House where final amendments to the measure could stir up old enmities and continue to the bitter end the controversies aired in committee hearings.

At its early hearings on the bill, the House Banking Committee heard many arguments for approval and from such potent organizations as the American Legion and the Veterans of Foreign Wars, among others.

Opponents of the public housing features of the bill, so successful previously in stopping the legislation at the Rules committee, were inclined to "give up the fight" after hearing of the heavy affirmative vote in the Senate. At this writing, however, the House decision hangs in the balance. The vote on the new labor legislation had indicated that a rambunctious House of Representatives could handily erect a roadblock to the President's proposals through a Republican-Southern Democrat coalition.

### Old Arguments Renewed

Meanwhile, all the long-standing pro and con arguments over the government's housing policies were dusted off and brought before the committees once again. Opponents repeated their charges that the Housing bills were socialistic in character, leading dangerously far in on the path toward outright government control of the building

industry. In this connection, Herbert U. Nelson, executive vice president of the National Association of Real Estate Boards, went so far as to say that final congressional agreement on federal housing plans would mean certain destruction of the private building industry in the field of rental housing.

"As many as 200,000 dwellings per year could be built under the Senate-approved bill," he said. "This is more than the total number of rental dwellings built by private industry in the U. S. in 1948, a record building year."

The public housers clung just as tenaciously to their own tenets. Their several statements to Congress argued that the need for a public housing program, and government "guidance" in research, farm housing, slum clearance and urban redevelopment, was never more evident than now.

In the debate before the House Banking Committee, the organized home builders attempted to persuade Congressmen that they are now meeting the needs of lower income groups. It was around this particular issue — federally-subsidized housing for those who can't afford current home construction —

that much of the entire argument was centered.

Outside the committee room N.A.H.B. charged that Administration forces had employed delaying tactics in a deliberate effort to use a hoped-for industry failure to bolster their own cause. The Association statement read: "It has been said that there are some within the Administration and the Congress who hope that private enterprise will not produce a high volume of housing this year — that our failure will assure their objective of socialized housing as the alternative. With four long months having already elapsed, and a minimum of another month ahead without the necessary assistance of the private housing bill being available, it is difficult to disbelieve such assertions. In any event, the spring building season has passed, volume is down substantially and last year's production goal cannot be matched. This unfortunate fact is directly and in large part attributable to the delaying tactics of this Administration."

As the old arguments raged on Capitol Hill, the threat of a large-scale government participation in the nation's housing effort was making its mark on private building trends. It was George W. West of Atlanta, Ga., chairman of the Construction and Civic Development Department Committee of the U. S. Chamber of Commerce, who defined this influence for Congress. The threat of government housing, he said, is already acting as a deterrent on pri-

(Continued on page 10)

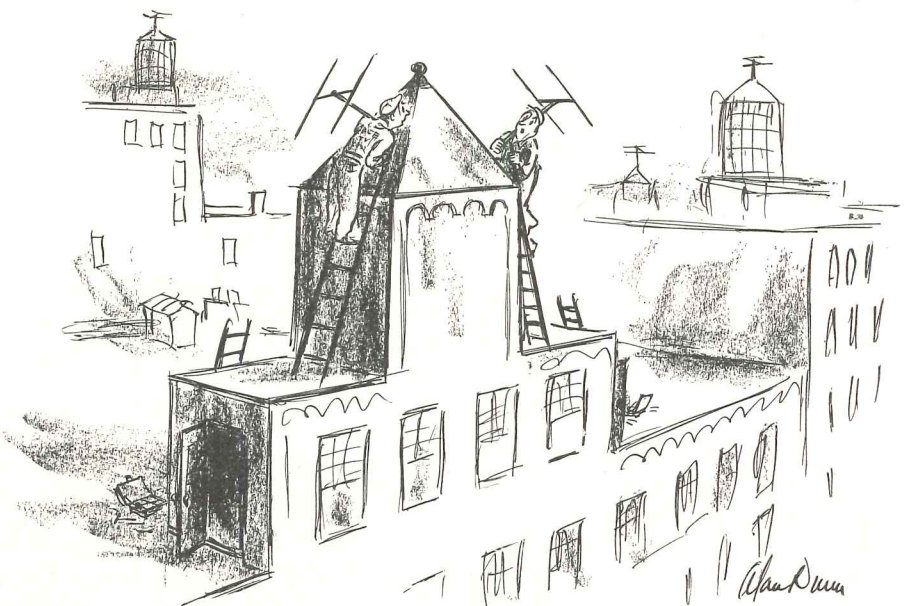

— Drawn for the RECORD by Alan Dunn

# It's here . . .



## WEYERHAEUSER

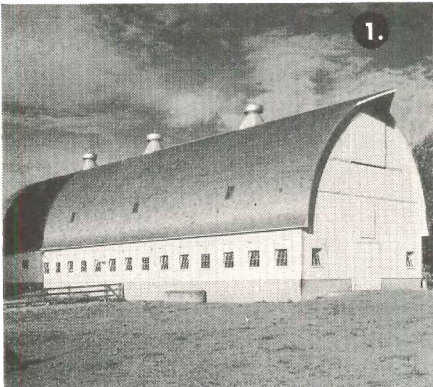

### BETTER BUILDING...LESS WASTE!

1. "I was amazed at the saving in time, material and labor", writes a contractor who used End-Matched lumber for siding and lining on a 66 x 100 foot dairy barn.
2. Interior lining of barn is made smooth, clean, and sanitary with End-Matched lumber.
3. Every piece of End-Matched lumber fits. No sawing needed . . . no time lost squaring up the ends. It lays up fast, and stays up tight.
4. Appearance counts too . . . and what could be better looking than the perfectly smooth under-surface of this fine home. End-joints are practically invisible.
5. Diagonal sheathing makes a sounder, more perfect building . . . and End-Matched lumber is ideal for the job. Let the joints fall where they may!

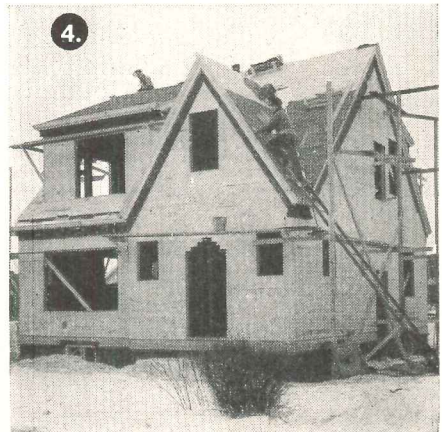
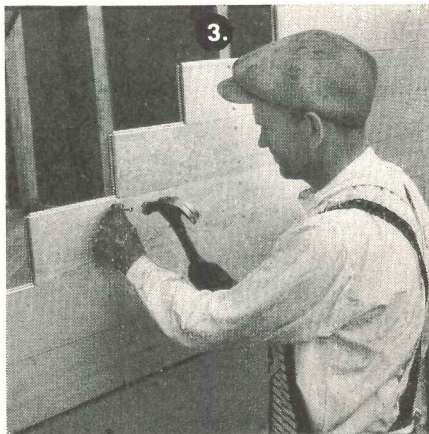
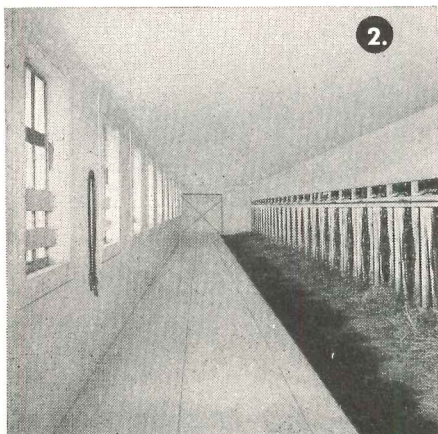
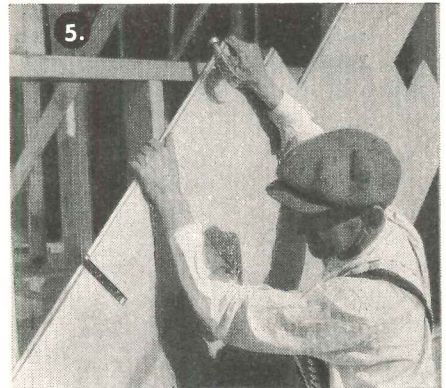



# ready NOW!

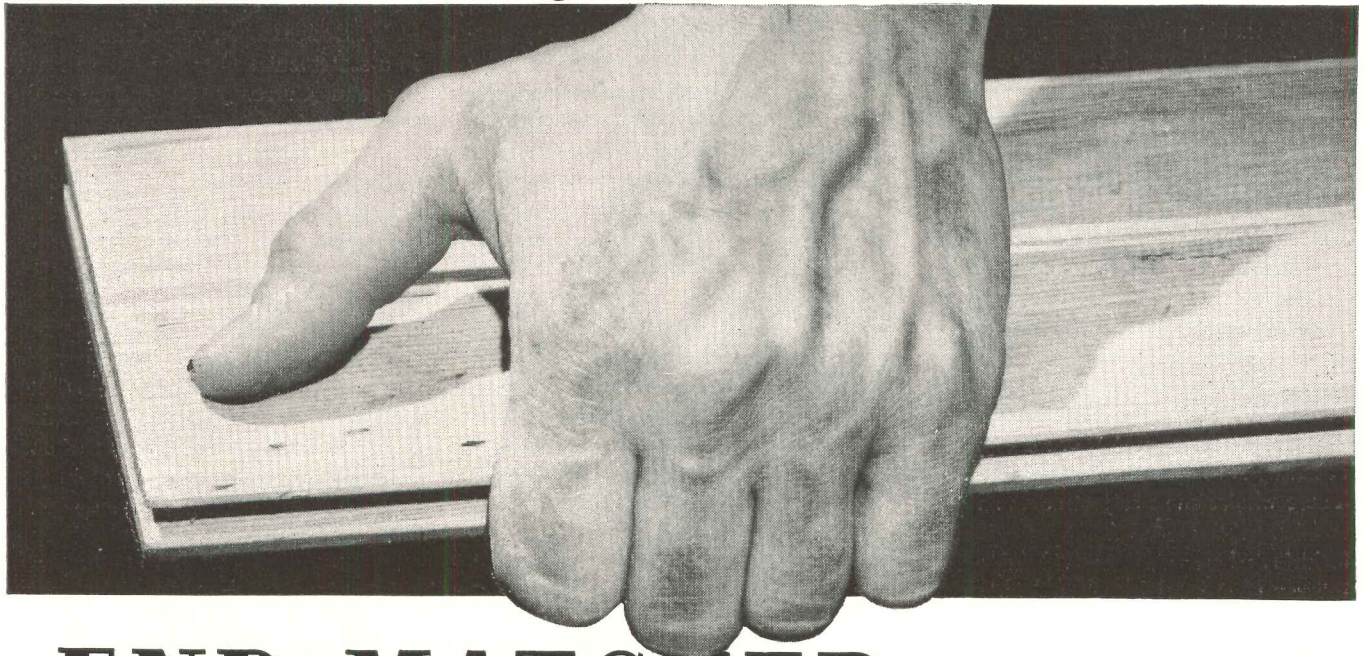

## END-MATCHED *Lumber*

Retail lumber dealers are in a position to furnish End-Matched lumber from softwood species of the West Coast . . . lumber that locks together at the ends and edges to form smooth, tight, rigid panels of any desired area. There is no waste with End-Matched lumber—no cutting and fitting of each piece. It makes possible sound, speedy construction at lowered cost.

End-Matched, with its superior construction qualities for sheathing, siding and flooring,

is extremely popular among builders who have used it and seen its extra values. They will be glad to know that End-Matched is available. The pictures on the opposite page illustrate some of the advantages of this superior lumber product.

Sound quality in lumber helps you win friends, build sales, increase your profits. You can offer that kind of quality in fullest measure, in Weyerhaeuser End-Matched Lumber!

**WEYERHAEUSER 4-SQUARE**  
**LUMBER AND SERVICES**

## THE RECORD REPORTS

(Continued from page 7)

vate building. People rightly hesitate to risk their capital in any field in which they must face the imminent possibility of government competition. He suggested that Congress could constructively stimulate private building by removing the threat of such government competition in the field of housing.

West joined with many other critics in asserting that the critical shortage in housing now has been overcome. Entering a new phase of postwar activity, the construction industry finds itself in a buyers' market. Competition is tougher. Buyers are getting better bargains. Profit margins and costs are being reduced. As always, the forces of a free market are compelling those adjustments which must be made if the economy is to operate on a sound basis. These wholesome readjustments should

not be interfered with by undertaking a large program of subsidized government housing. Thus West summed up pretty clearly the attitude of the major portion of the building industry.

### No Objections to Research

Very little objection to the housing research section of the bill, however, was voiced by the witnesses at the House hearings. This part of the bill eventually could have profound effect upon the trends of the construction industry. Its provisions are broad. Designed to promote progressive reductions in housing costs and at the same time to increase the housing supply through probing new techniques and materials, this research section also deals with inventories of need. Under it, the housing administrator would make his own inventories of urban and rural nonfarm housing needs and the progress toward meeting them, at the same time encouraging local authorities to make similar studies, surveys, and plans with respect

to their own needs, markets and development.

The federal program of housing research as envisioned in Title III is generally acceptable to the building industry, though some concern has been expressed by those who favor definition of prescribed limits for federal participation. Thomas S. Holden, president of F. W. Dodge Corp., voiced that concern in a statement before the House Banking and Currency Committee which read in part:

"... Section 301 (a) of the bill defines the province of technical research as including development, demonstration and promotion of the acceptance and application, among other things, of new materials. It states that the contemplated research program may be concerned with new and improved types of housing components, building materials and equipment and methods of production and distribution of such materials as well as with matters per-

(Continued on page 12)

## NEWS FROM CANADA

By John Caulfield Smith

### Dwelling Code to Come First

Hope that uniformity of building by-laws can be achieved exists as the result of a recent meeting of building officials sponsored by the Division of Building Research, National Research Council, in Ottawa. The meeting was called to consider revision of Canada's National Building Code to meet the current needs of municipalities.

It was agreed that, since the Code does not deal specifically with residential construction, the first job should be to prepare a code for dwellings. This is to be followed by revision of the present condensed version of the National Code for small and medium-sized communities and, finally, by revision of the Code itself. The new Codes will be correlated and written in "layman's language." They'll be kept flexible enough to provide for new developments, since it is likely that a real reduction in construction cost can only result from the introduction and use of new materials and methods.

The Research Council's function is an advisory one only. It does not report to the Dominion Government, but to the Privy Council. The securing of uniformity of municipal building by-laws is a matter for provincial jurisdiction. During the coming months the Division of Building Research will call joint meet-

ings of provincial and municipal officials to confer on the legislation required to enable cities and towns to adopt the new codes in by-law form. The results of the meetings will then be reported at next year's meeting of building officials.

### Building Wages Rank Second

Construction workers got bigger hikes in pay in 1948 than any other employee group, with the exception of the one engaged in transportation and communication. The increase in building wage rates over 1947 was 13.7 per cent, just slightly above the general average increase of 13.0 per cent.

The accompanying table from the Department of Labor shows the six principal industrial divisions and the general average index numbers with percentage increases. The index is based on 1939 rates: 100.

Industry	1948	Percentage Increase over 1947
Logging.....	218.8	12.1
Mining.....	182.1	12.6
Manufacturing.....	206.4	12.6
Construction.....	176.3	13.7
Transportation & Communication.....	175.3	17.4
Service.....	183.2	7.4
General Average.....	196.3	13.0

### Low Grade Lumber For Houses?

Solid cedar construction is being touted by British Columbia lumbermen as being competitive in price with ordinary wood framing. Purpose is to employ lower grades of lumber which are becoming increasingly difficult to market.

According to the newly formed B. C. Coast Woods Trade Extension Bureau, solid cedar construction is durable, strong, fire-resistant, and possesses insulating qualities. The Bureau advocates using a 2 in. plank wall, with exterior finish applied directly and interior finish applied on strapping to give an insulating air space.

### Materials Inch Up In Price

A residential index developed by the Dominion Bureau of Statistics which records price changes for materials used in housing, as against the general materials index, permits new comprehension of the price movements of building materials.

Housing materials hold the lead. During February the index rose slightly. It averaged 230.4 compared with 230.0 in January and 229.0 in December. The index of general building materials rose from 203.8 to 204.3 in February. Both indices are based on 1935-39 figures: 100.0.

(Continued on page 156)

# Beauty

**THAT'S MORE THAN SKIN DEEP**

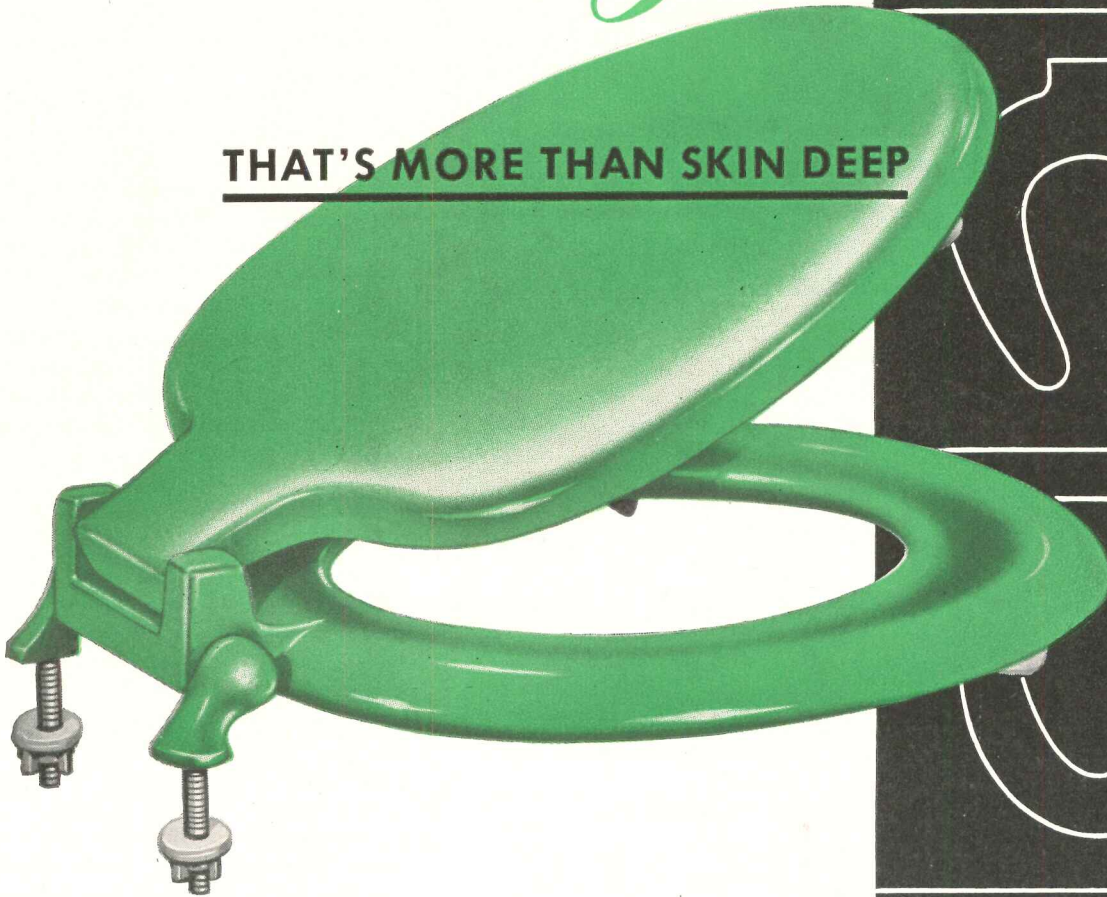

Bathroom beauty and long life, are but two features that keynote solid Olsonite seats. Their beauty and durability has convinced industry and home owners alike, that there is no better seat. Whenever solid Olsonite is specified—chip proof, peel proof, stain proof, fire and wear resistant, long life is assured. See your plumbing and heating distributor, jobber or contractor.

# Olsonite

Division of Swedish Crucible Steel Co.  
8561 BUTLER AVENUE • DETROIT 11, MICHIGAN

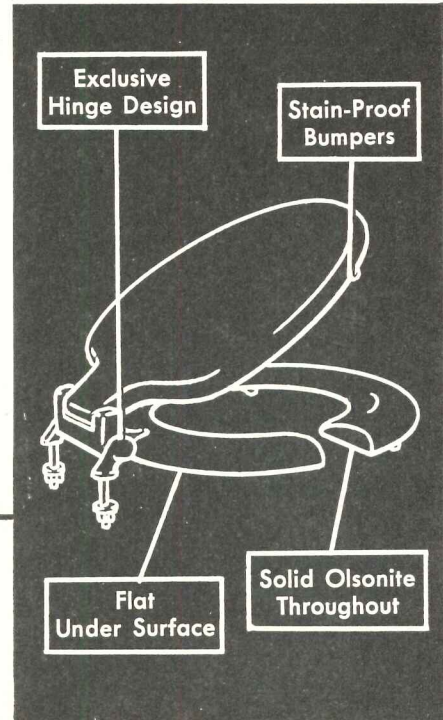
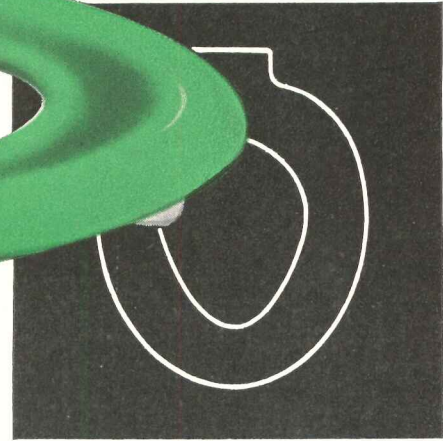
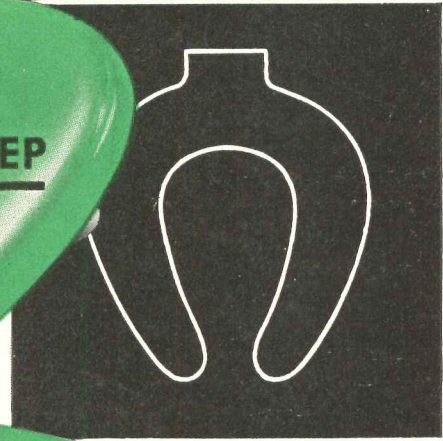
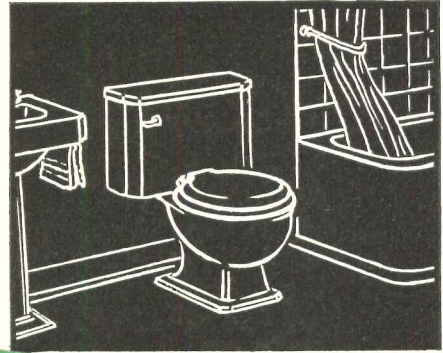



**GUTH TEAMWORK**  
takes the "quest"  
out of your  
lighting questions

The science of lighting becomes more complex...and more important: it takes closer teamwork between planner, manufacturer and supplier to assure top-quality illumination.

When you join hands with **Guth**, you'll find that teamwork. Every fixture is **precision-planned** for functional efficiency in operation, installation and maintenance. What's more, you'll find your nearby **Guth** Distributor and **Guth** Resident Engineer competent and cooperative...a mighty big help in producing precision-planned installations you can be proud of.

Do you have a time-saving **GUTH** Lighting Calculator and Layout Guide 33-J? They're yours for the asking, with the compliments of



YOUR TEAMMATE IN *precision-planned* LIGHTING

**Guth**

**LIGHTING**

THE EDWIN F. GUTH COMPANY / ST. LOUIS 3, MISSOURI

*Leaders in Lighting Since 1902*

661

## THE RECORD REPORTS

(Continued from page 10)

taining to design, methods of assembly, testing techniques and performance standards. Creative research, involving invention and new product development, and promotion of the acceptance of new products, have always been the province of private enterprise, which has made substantial and continuous progress in this respect. I strongly urge that the text of Section 301 (a) be amended so as to define clearly the appropriate limits of technical research by government."

Mr. Holden recommended further that in formulating technical research programs, the housing administrator be required to consult with the National Academy of Sciences, the rightful agency, along with the National Research Council, to coordinate programs of scientific research.

### Economy Is a Real Issue

Party line cleavages have deepened considerably on the economy issue. Airing of the joint committee findings on the President's Economic Report have spotlighted this in recent weeks. While signs of the smoldering Republican resentment toward "free" spending have long been evident, they climaxed only a month ago when Senate minority leaders secured enough votes to send back to committee the big Labor-Federal Security appropriations measure. It was recommitted for a 5 per cent trimming.

This marked a beginning. Senator Robert O. Taft, who has sparked the economy drive in the upper chamber of the Congress, said similar moves would be made on his side of the aisle on all appropriation measures; that the trimming-back feature would be attempted at least.

Actual money cut involved in the Senate's action would have amounted to less than \$16 million since most of the items in the Labor-Federal Security measure are specifically allocated by law and therefore could not be reached by the action. The attempted cut was a comparatively small amount when weighed against the nearly \$2400 million overall sum approved by the House in this bill. But the significance lay not so much in comparative totals involved as in the initiation of a pattern of economy strokes closely bound up

(Continued on page 14)

# **demand** **DETROIT CERTIFIED CONTROLS**

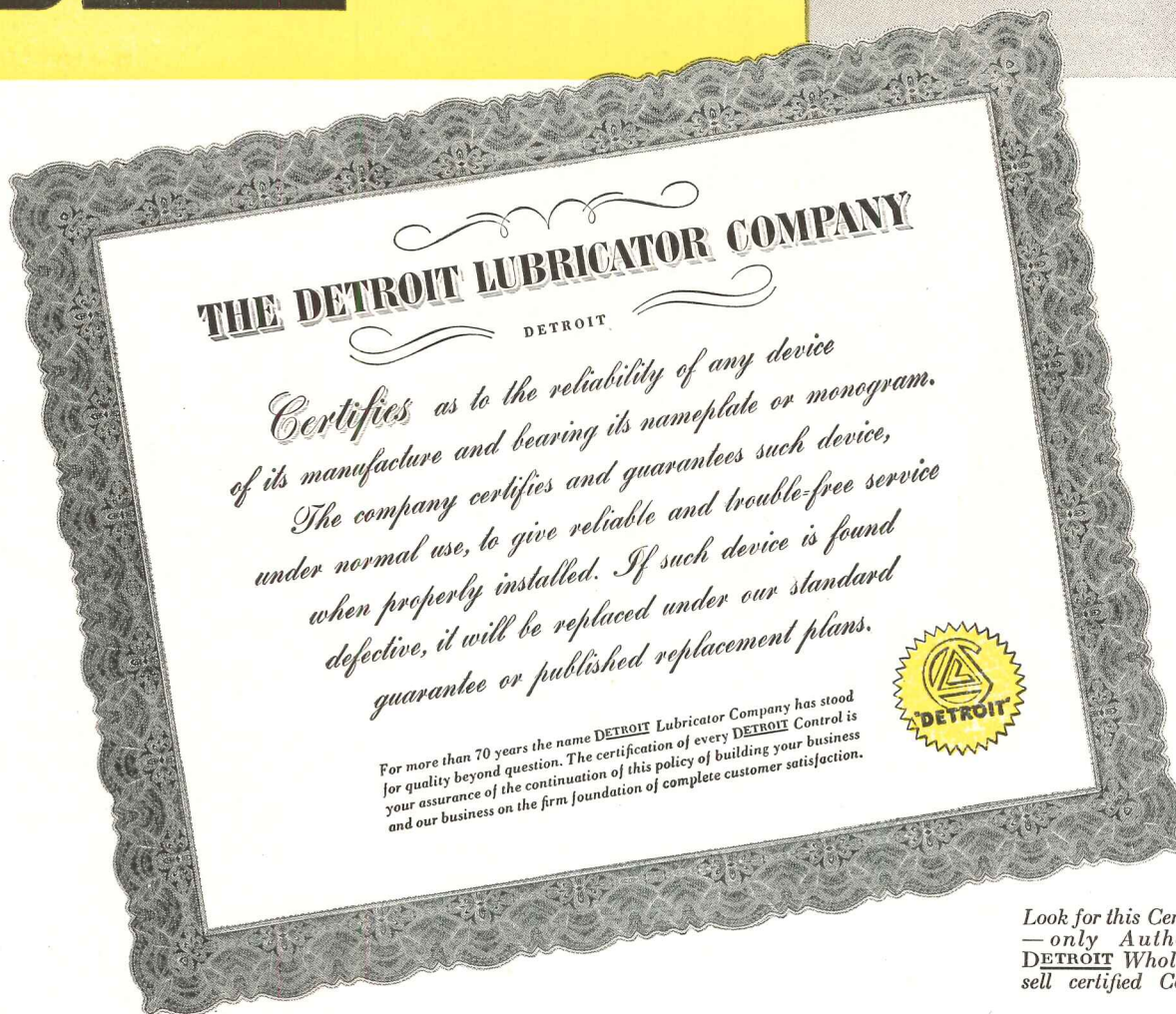

Look for this Certificate  
— only Authorized  
**DETROIT** Wholesalers  
sell certified Controls.

## **Protecting YOUR Reputation—Maintaining OURS**

**DETROIT**, famous for quality for over seventy years, now offers you the most aggressive and complete backing in its history. In addition to **DETROIT'S** great nation-wide distributing organizations and an exceptionally well qualified factory service group, every control in the **DETROIT** line is Certified. This means Controls you can sell with confidence because

they are built to give your customers the maximum in convenience, reliability and economy—greater satisfaction for users, added profit for you. The next time you order heating controls, specify **DETROIT**. For, only with **DETROIT** do you get the important plus value of this Certified Quality—protecting your reputation, maintaining ours.

# **DETROIT**

## **LUBRICATOR COMPANY**

5900 TRUMBULL AVE., DETROIT 8, MICHIGAN

Division of **AMERICAN RADIATOR & Standard Sanitary CORPORATION**

CANADIAN REPRESENTATIVES: RAILWAY & ENGINEERING  
SPECIALTIES, LTD. — MONTREAL, TORONTO, WINNIPEG

**DETROIT HEATING AND REFRIGERATION CONTROLS •  
ENGINE SAFETY CONTROLS • FLOAT VALVES AND OIL  
BURNER EQUIPMENT • DETROIT EXPANSION VALVES  
AND REFRIGERATION ACCESSORIES • STATIONARY  
AND LOCOMOTIVE LUBRICATORS**

*Serving home and industry* AMERICAN-STANDARD • AMERICAN BLOWER • CHURCH SEATS • DETROIT LUBRICATOR • KEWANEE BOILER • ROSS HEATER • TONAWANDA IRON

# SPECIFY

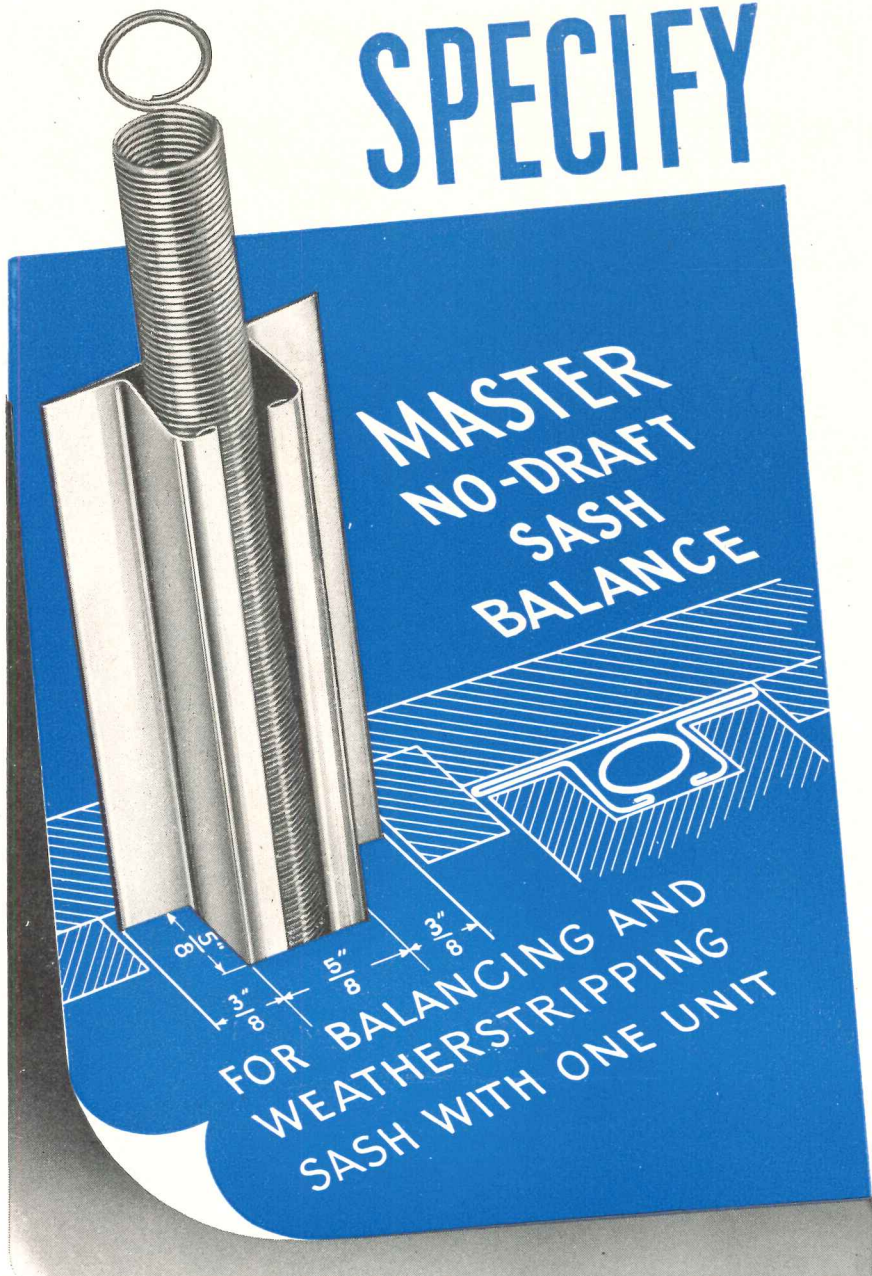

Two jobs finished for the work of one . . . and both done right. Perfect window operation and better weather protection in one piece of equipment. Entirely eliminates pulleys, cords, weights and box frames. Master No-Draft Sash Balance—permanent, time-proven and trouble-free—saves labor, time and money. Can be installed quickly and easily. This is the modern way to counterbalance and weatherstrip all double hung windows—old or new.

Acting as a perfect weatherstripping for both sides of a window, Master No-Draft Sash Balance will automatically adjust itself to any amount of shrinkage or expansion in the wood.

The unit is made of highly tempered, rust-proof metal for long enduring service. Correctly tensioned springs give upper and lower sash perfect balance and easy fingertip operation.

Runways are completely metal covered and require no painting, (of course, cross members should be installed). Double contact prevents any rattle when windows are open.

The Master No-Draft Sash Balance gives a neater appearance to all windows and makes a more weather-tight window. Nothing to wear out or cause trouble.

SEE OUR CATALOG IN SWEET'S <sup>17</sup>/<sub>5</sub> a

**MASTER METAL STRIP, INC.**  
1718 N. Kilbourn Avenue  
Chicago 39, Illinois

**MASTER NO-DRAFT SASH BALANCE**  
Please send me, without obligation, complete information about Master No-Draft Sash Balance.

Please send detailed literature at once.

Name.....  
Title.....  
Address.....  
City..... Zone..... State.....

## THE RECORD REPORTS

(Continued from page 12)

with the whole matter of taxation. Taft struck directly at the Administration's desire to increase taxes when he summarized the minority views of the Joint Economic Committee on the President's Economic Report. He informed the Senate that Republican members of the committee reject the "basic philosophy" of the President's economic treatise. More specifically, Taft said the President ignored the broad powers already in his possession, particularly in regard to control of credit and determination of fiscal policy. The "crusade for more executive power" was branded unjustified and dangerous.

### Minority View Specific

The Republicans anticipate that corporation profits will fall rapidly if volume of business progressively decreases. Capital investment would come harder under these circumstances. The minority interprets the committee evidence as indicating that while capital investment may be slightly more now than should be permanently maintained, there is more danger in the long run of under-investment than of over-investment as long as the present tax structure remains in effect.

Thus Taft summed up: "In fact, we feel that the greatest threat to the stability of our economy and the prosperity of the United States lies in the constantly increasing burden of government taxation and the difficulty of securing capital for the steady maintenance of employment in the capital goods industries so there may be a continued increase in consumption."

### Construction Affected

These hoped-for economies in government spending certainly would shape an imprint on the nation's construction pattern. The House Appropriations Committee recommendation, adopted by the House, cutting 15 per cent from the huge civil works expenditures for fiscal 1950—just in anticipation of lower building costs—had earlier shown industry something of the Congressional "frame of mind" on this subject. (Of course, the stipulation was hedged around with a monetary safeguard. The committee told the Army Corps of Engineers it could come in for supplemental appropriations in event it was caught short by the reduction in the fiscal year

(Continued on page 16)

YOU CAN BE **SURE**.. IF IT'S  
**Westinghouse**

*Announcing...*

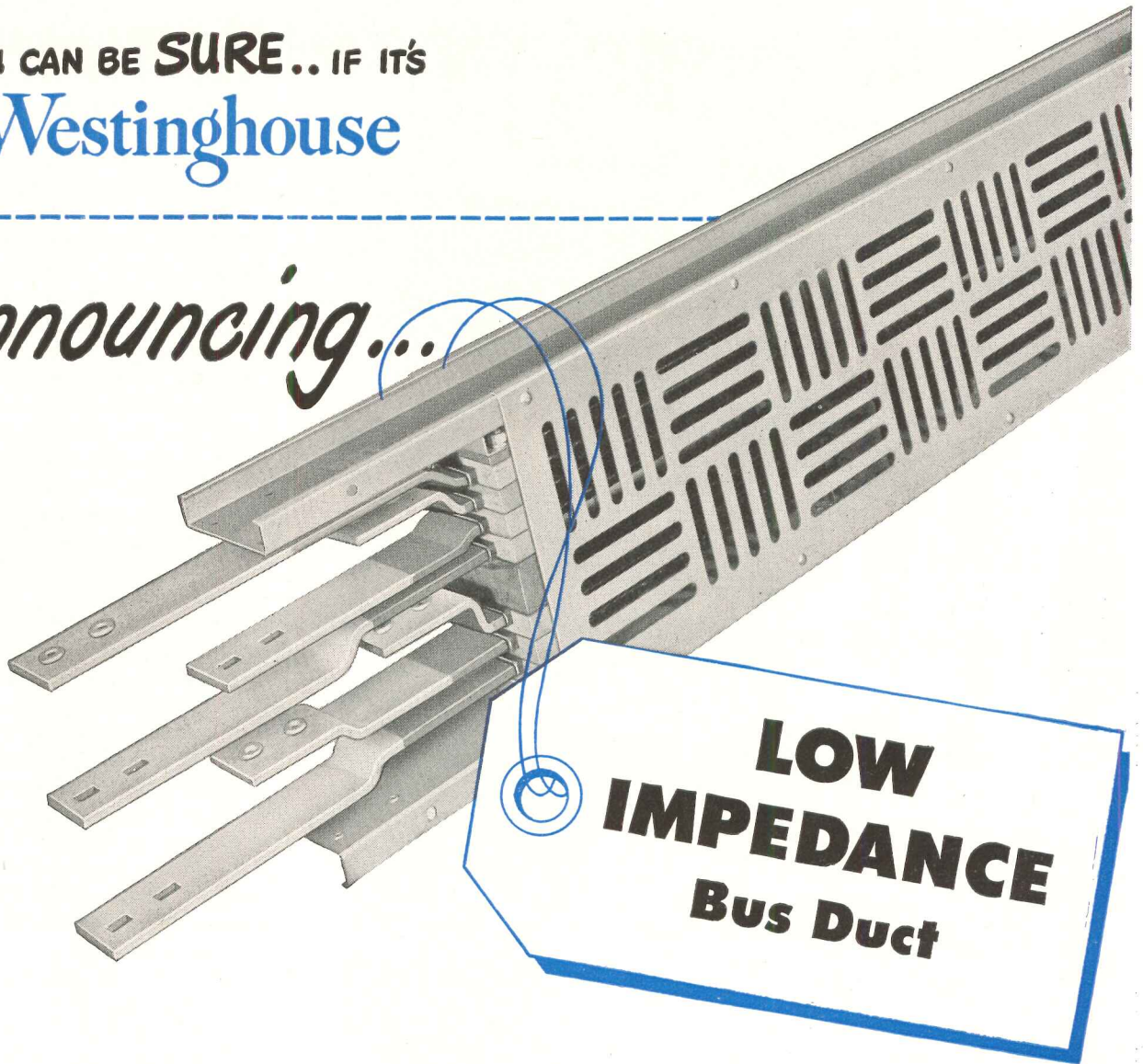

... for better "long haul" power distribution

Now you can lick the problem of excessive voltage drop in long feeder runs. New, Westinghouse Low Impedance Bus Duct is the equipment you need.

Close spacing and interlacing of busbars in low impedance duct assure *low* voltage drop . . . actually about one-half of that for conventional plug-in or feeder duct. This permits more efficient operation of electrical equipment served by long feeder runs.

Low impedance duct safely withstands high short-circuit stresses and is economical on high-capacity circuits. Its steel housing is *small* to conserve space . . . *ventilated* to

decrease temperature rise . . . *Bonderized* to prevent rust and corrosion.

Don't gamble with a crippling low-voltage condition. Be *sure* with Low Impedance Bus Duct!

For full details write Westinghouse Electric Corporation, P.O.Box 868, Pittsburgh 30, Pa.

J-30002

**Westinghouse**  
**Bus Duct**



## THE RECORD REPORTS

(Continued from page 14)

ahead — and with reasonable assurance some deficiency requests would be granted.)

No leniency will be shown in the new attempt to tone down the growing government outlays, however.

While lambasting the Truman report on the economic state of things, and its implied ultraliberal methods for dealing with prospective developments, Taft's presentation of the minority report from the committee took a somewhat softer view of specific housing problems. One of the renewed recommendations was that the federal government take an active interest in the development of housing, particularly in the stability of the housing industry and the reduction in housing costs.

The pendulum of party doctrine had swung far to the other extreme on most issues in the majority report filed earlier. There was less difference shown, however, on the two housing points raised by Taft. The Democrats, in their report, had called housing "another industry in which private investment seems to fail at least in part to meet the basic needs of the economy." Furthermore, the majority findings accuse the home building industry of contributing significantly to the "instability of the economy as a whole" through its violent fluctuations in the past.

For these reasons industry is watching closely the outcome of this economy strife on Capitol Hill.

One needed to go no further than the recent credit ruling of the Federal Housing Administration for an exact illustration of what Taft meant in his reference to broad fiscal powers already in the hands of the Administration. Following hard upon the Federal Reserve Board's loosening of credit regulations was FHA's notification to all lending institutions that the 10 per cent cash down payment on Title I loans for modernization and repair no longer would be required. Though FHA didn't say so itself, this action was strictly in line with the Reserve Board's relaxation of credit requirements and a part of the government attempt to adjust its fiscal policies to the changing times.

### Control Pops up again

Taft's Senate speech once again formulated the Republican viewpoint on the question of more federal controls.

(Continued on page 18)

# How To Reduce Designing, Purchasing & Building Time

## WITH MACOMBER FACTORY-MADE STEEL LOAD BEARING MEMBERS

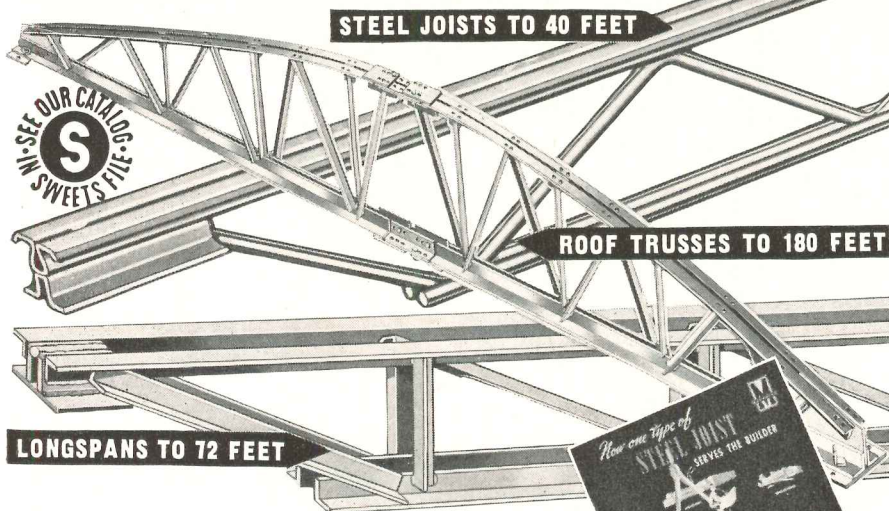

### DESIGNING TIME

Nothing could be simpler than a steel framing plan for Macomber Steel Joists, Longspans, Trusses and Purlins—a line on a drawing, a glance at Macomber Standard Loading Tables for carrying capacity and catalog number.

### PURCHASING TIME

You can place ONE ORDER for the entire steel structure including steel columns, eave struts, decking, mesh and temperature rods. Your steel is scheduled as needed from PLENTIFUL supplies.

### BUILDING TIME

Macomber factory-made Load Bearing units can be set in place in a fraction of the time and labor required to build them on the job. You reduce your cost, construction time and responsibility. You have the KNOWN, DEFINITE loading capacities of steel. These catalogs will help you. No obligation.

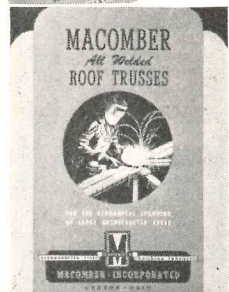

V-BAR JOISTS AND PURLINS • V-STUDS • TRUSSES • LONGSPANS • DECKING

SERVICE IN STEEL

STANDARDIZED CONSTRUCTION

**MACOMBER**

INCORPORATED  
CANTON, OHIO

IN CANADA, SARNIA BRIDGE CO., LIMITED, SARNIA, ONT.  
IN MEXICO D. F.—MACOMBER DE MEXICO S. A. CEDRO 500

STANDARDIZED STEEL BUILDING PRODUCTS



**SELECTED** for appearance . . . for performance

**FOR GENERAL PETROLEUM  
OFFICE BUILDING  
IN LOS ANGELES**

Architects:  
Walter Wurdeman, A.I.A.—  
Wilton Becket  
General Contractor:  
P. J. Walker Co.

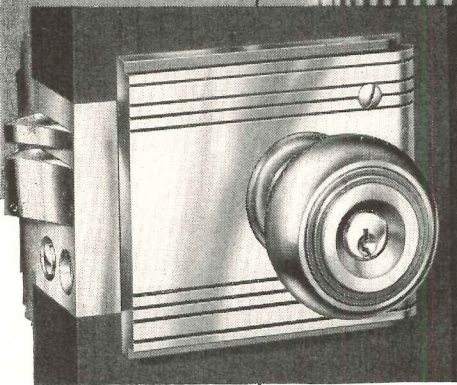

## **RUSSWIN UNIT LOCKS in Century Design**

There are many reasons why Russwin Unit Locks have been selected for so many of today's outstanding buildings.

Russwin Unit Locks practically eliminate costly maintenance problems. They're easier to install—no mortising, no deep cuts are

needed—saving time, labor and money.

You can specify Russwin Unit Locks unreservedly for any apartment, office or public building. Compare them—you'll see why. Russell & Erwin Division, The American Hardware Corp., New Britain, Conn.

SINCE 1839

# **RUSSWIN**

DISTINCTIVE HARDWARE

*dealers always have the edge*

We've built  
a better  
"noise trap"

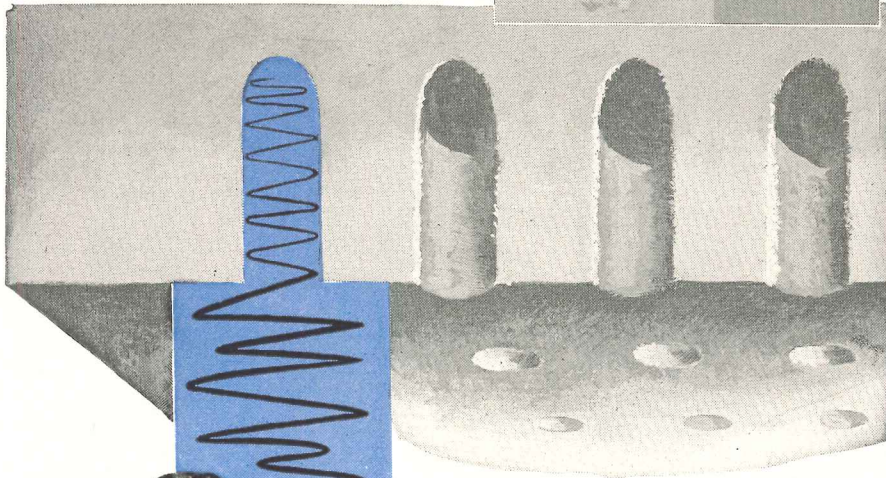
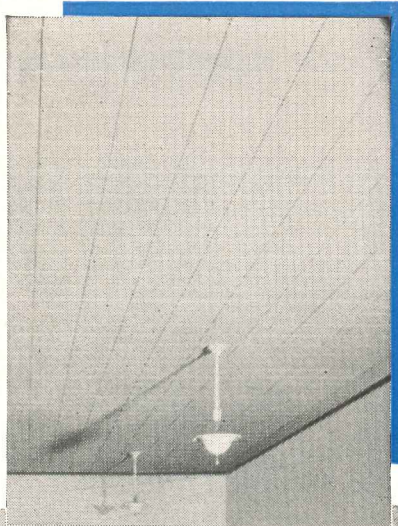

\*Based on room size 15' x 15'  
†Reg. U. S. Pat. Off.

You'll have **108,900\*** noise traps to give you quiet, when you buy a **Johns-Manville Fibretone† Ceiling**

• Every 12" unit of a Johns-Manville Fibretone Ceiling has hundreds of scientifically designed "noise traps". . . small cylindrical holes drilled in the sound-absorbing panels.

Here the noise waves are trapped and dissipated *within* the holes.

Once you experience the benefits that noise-quieting Fibretone gives . . . greater comfort, less nerve strain, increased efficiency . . . you'll never again be satisfied to have an ordinary ceiling in any busy area. You'll be surprised, too, at Fibretone's *low cost*.

**Send for Free, Fascinating Booklet:** Whether you're interested in quieting an office, restaurant, bank, school, or factory, let us tell you more about Fibretone. Write for our new brochure, "Fibretone."  
Johns-Manville,  
Dept. AR-6,  
Box 290, New  
York 16, N. Y.

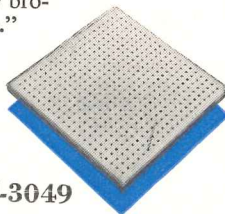

T-3049

Put a ceiling on noise with



**Johns-Manville FIBRETONE CEILINGS**

## THE RECORD REPORTS

(Continued from page 16)

Chief argument for added federal regulations in the President's report was seen by the minority to be a need to combat further inflation. The minority handled it in this way: "We see no justification for the claim that there now exists any serious danger of inflation. We believe that the economy has very largely adjusted itself through natural processes to a point where there is a reasonable balance between prices and wages, industrial prices and farm prices, savings and investment, consumption goods and capital goods.

"We believe that while business and profits and investment are perhaps somewhat out of proportion, they will both be rapidly adjusted downward as the buyers' market takes effect."

### Shorts

- The long-awaited Supreme Court ruling in the rigid steel conduit case was announced, upholding the Federal Trade Commission order which virtually outlaws the basing point method of pricing manufactured products. It did nothing to remove the cloud of confusion that surrounds the government's policies in this matter. It served only to speed action by Congress toward declaring a moratorium on basing point cases in the courts for two years while Congress decides what action it wants to take to clarify the whole question of basing point quotation and freight absorption. The 4 to 4 Supreme Court decision affirmed the ruling of a lower court. This meant that the vote of the individual Justices remained unannounced and that no explanatory statement accompanied the ruling.

- A handbook prepared for the Veterans Administration by the Bureau of Labor Statistics says the outlook for construction employment is "good" over the next several years. This occupational outlook handbook, running 454 pages in length, predicts strong demands for construction will lead to a new high level of employment unless there is a marked decline in general business conditions. It anticipates that design and technological changes will continue to affect the relative needs for the different construction trades as the general demand for employees increases.

- Public Roads Administration bolstered its argument for an expanded

(Continued on page 20)

**1<sup>ST</sup>**  
 A. O. Smith was first to offer  
 complete built-in protection  
 against rust...because GLASS  
 cannot rust.

# 2 MILLION BENDS Prove Long Life of Glass-Surfaced Water Heater Tank!

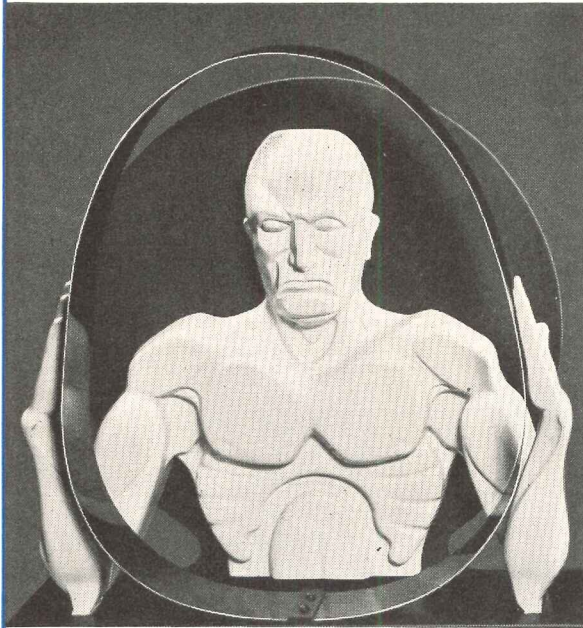

GLASS THAT BENDS within the elastic limits of the steel is demonstrated by this "mechanical man" flexing a special thin ring of SMITHway glass-fused-to-steel. The ring pictured here has been flexed more than *two million times* . . . yet the glass surface is still in perfect condition.

The Multiple Flex Test, pictured here, the Thermal Shock Test, and other conclusive demonstrations prove the durability and resilient toughness of the glass-surfaced heavy steel tanks of *Permaglas* Automatic Water Heaters. The fact that the diamond-tough inner glass surface will not crack or chip under even extreme shipping, installation, and operating conditions is also proved by the performance record of hundreds of thousands of installed units.

This dependable, built-in protection against rust forming in the tank is a major reason why *Permaglas* Water Heaters provide completely satisfactory automatic hot water service, at the lowest actual cost. For ALL the reasons why "*Permaglas*" means complete satisfaction, send the coupon today.



"PERMAGLAS"  
 Dealers Display  
 This Emblem

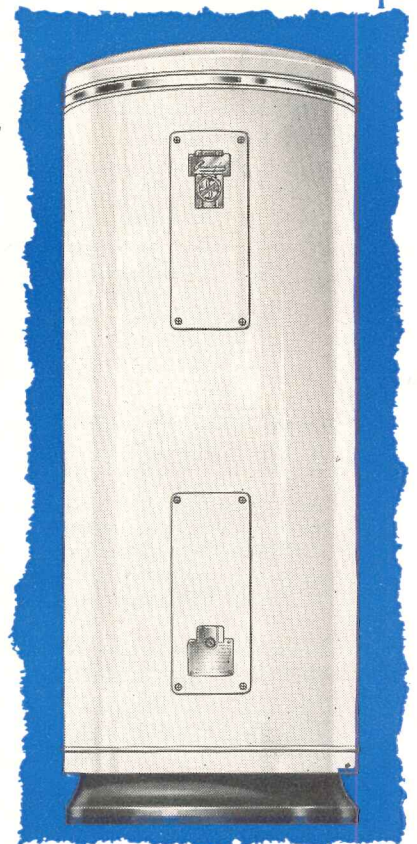

Gas or electric models, or new electric table-top, in sizes for all home needs.

# Permaglas

TRADE MARK REG U S PAT OFF

## A SMITHway WATER HEATER\*

\*Also quality zinc-lined *Duraclad* and *Milwaukee* Automatic Water Heaters

A. O. SMITH CORP.  
 Dept. AR-649  
 Water Heater Division  
 Kankakee, Illinois

● Without obligation, send us complete information on SMITHway Water Heaters.

Electric  Gas  
 Both

Name \_\_\_\_\_  
 Firm \_\_\_\_\_  
 Street \_\_\_\_\_  
 City \_\_\_\_\_ State \_\_\_\_\_

A. O. SMITH Corporation  
 Atlanta 3 • Boston 16 • Chicago 4  
 Clayton 5, Mo. • Philadelphia 3  
 Denver 2 • Detroit 2 • Houston 2  
 Los Angeles 14 • New York 17  
 Dallas 1 • Midland 5, Texas  
 Pittsburgh 19 • San Francisco 4  
 San Diego 1 • Seattle 1 • Tulsa 3  
 International Division:  
 Milwaukee 1  
 Licensee in Canada:  
 John Inglis Co., Ltd.

(Continued from page 18)

# Where Wood Needs Protection from DECAY and TERMITES

**WOLMANIZED**  
PRESSURE TREATED LUMBER

... lasts 3 to 5 times longer

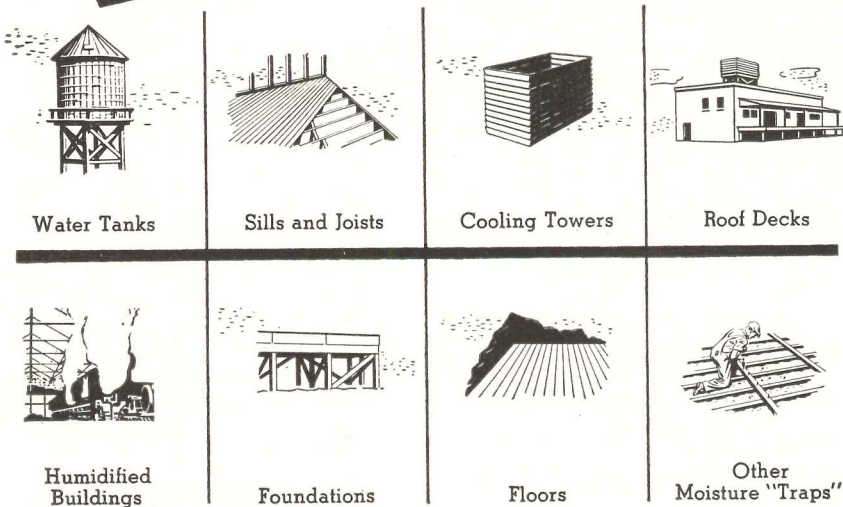

Here are six common conditions where WOLMANIZED Pressure-Treated Lumber provides protection from decay and termites:

1. Where excessive ground moisture, rain or thaws cause early decay failures.
2. Where wood near the ground is open to termite attacks.
3. Where wood is in contact with damp concrete or masonry.
4. Where steam and vapor from industrial processes promote wood decay.
5. Where walls, floors, ceilings are subject to condensation from refrigeration.
6. Where wood is exposed to moisture in artificially humidified buildings.

Investigations by qualified technologists prove that on installations where decay and termites ordinarily shorten lumber life, WOLMANIZED Pressure-Treated Lumber lasts *Three to Five Times Longer* than untreated wood.

Such lasting protection is assured because penetrating, preservative solutions are forced, by vacuum-pressure treatment, deeply into the wood fibers of WOLMANIZED Lumber. And, WOLMANIZED Lumber is clean, odorless, paintable, non-corrosive, non-leaching and glueable. Only WOLMANIZED Lumber offers *all* these extra advantages.

**FIND OUT HOW WOLMANIZED LUMBER  
GIVES YOUR CLIENTS EXTRA VALUE**

This informative booklet tells you all the facts about WOLMANIZED Lumber, and how it saves time and money for your clients. Be sure to have a copy—write for yours today.



**AMERICAN LUMBER & TREATING COMPANY**

General Offices: 332 South Michigan Avenue, Chicago 4, Illinois

Branch Offices: Baltimore, Boston, Jacksonville, Fla., Los Angeles, New York, Philadelphia, Portland, Ore., San Francisco, Washington, D. C.



highway construction program with announcement that the number of private and commercial vehicles crowding the nation's roads in 1948 had increased 8.7 per cent over 1947. There were 40,622,264 such vehicles registered last year, an increase of 3,261,801.

• Further indication of the drift with respect to supply and demand: the Commerce Department abolished export controls over some 500 items including lumber and flooring, plaster-board, wallboard, tile and structural clay products, iron and steel enameled bathtubs and other plumbing fixtures, cooking and heating equipment, home appliances and tools and builders' hardware.

• Federal Works Agency Administrator, Maj. Gen. Philip B. Fleming, was transferred by President Truman to the chairmanship of the Maritime Commission and Jess Larson, former War Assets Administration chief, was named to head the Works Agency.

• President Truman signed the first real housing law of the session — an Act enabling the Housing and Home Finance Agency to promote settlement and development of Alaska by facilitating construction of necessary housing in the Territory. A fund of \$15 million is provided for the purpose.

• Congress tackled the question of too little housing for military and naval personnel here at home. A Senate Banking subcommittee held hearings on a bill by Sen. Wherry and others to establish a system of mortgage insurance aids for rental housing construction similar to those now available under Section 608 of Title VI of the National Housing Act. Deplorable housing conditions in and near military installations were described by Army personnel.

• The American Federation of Labor, or at least its Building and Construction Trades Department, came out in bold opposition to the government's economy housing program. Richard Gray, the department's president, told the House Banking Committee objections were based on restriction of space and the belief that the program advocates leaving out housing essentials such as ice boxes and ranges. Seven hundred square feet, said Gray, is not enough space in which to raise a family. He objected, too, to the lack of facilities in the

(Continued on page 22.)

# New, Beautiful "REX-LITE 40"

combines scintillating beauty  
with advanced performance!



*Check All 5* when you buy, specify or recommend fluorescent lighting fixtures for Stores, Restaurants, Offices or other Commercial Locations!

*Good Looking-  
Good Lighting-  
Good Selling!*

With the new "Rex-Lite 40" Fluorescent Units, your commercial lighting plan has a distinct advantage of functional design beauty combined with a unique, soft, pleasing quality of light.

"Rex-Lite 40" pendant units are rated as a semi-direct unit with prismatic, polysterene diffusing panel located above the two outside lamps which provide even distribution of the illumination in the upward zone.

"Rex-Lite 40" ceiling type units are rated as direct units with 5% of the light directed upward.

#### PENDANT TYPE DATA

Total unit efficiency	<b>59%</b>
Total lumens above 90 degree zone	<b>24%</b>
Side shielding	<b>27 degrees</b>
End shielding	<b>13 degrees max.</b>
Maximum brightness inside shielded zone	<b>1.7c/sq." (768FTL)</b>

#### CEILING TYPE DATA

Total unit efficiency	<b>52.5%</b>
Shielding same as pendant unit	
Maximum brightness inside shielded zone	<b>2 c/sq." (904 FTL)</b>

Write now for complete **DATA BULLETIN** on the New Benjamin "Rex-Lite 40" Fluorescent Unit. **BENJAMIN ELECTRIC MFG. CO., DEPT. Q1, DES PLAINES, ILLINOIS.**

- ✓ **FUNCTIONAL DESIGN**  
Eye-pleasing simplicity, streamlined styling, designed to harmonize with modern commercial decoration.
- ✓ **DIFFUSING ALL-PLASTIC PANELS**  
For uniform illumination . . . designed to relieve disturbing contrasts. These panels also reduce accumulation of dust and dirt inside reflector.
- ✓ **HIGH LIGHTING EFFICIENCY**  
Porcelain Enamel reflecting surface, unequalled for high light output with maximum diffusion. Finest quality ballast and starter equipment reduces annoying flicker and minimizes costly service interruptions.

- ✓ **BENJAMIN BUILT-LIKE-A-BATTLESHIP CONSTRUCTION**  
Maximum durability . . . an extra margin of strength in every part . . . maximum freedom from obsolescence and maintenance trouble.
- ✓ **LOW COST MAINTENANCE**  
Simple soap-and-water cleaning restores Porcelain Enamel reflecting surface to original lighting efficiency. Porcelain Enamel cannot corrode, oxidize or deteriorate.

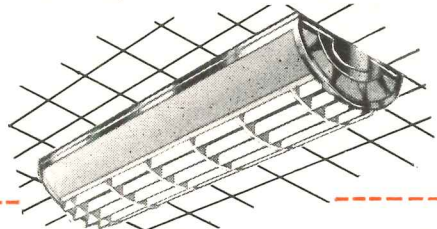

"Rex-Lite 40" Units are available in pendant or ceiling units. Either type can be installed independently or butted end-to-end to form continuous lines by using a specially designed coupling.

## BENJAMIN

*Lighting Equipment*

Distributed Exclusively Through Electrical Wholesalers R-3058

## THE RECORD REPORTS

(Continued from page 20)

“and now...  
a special  
announcement”



“to all architects designing TV or AM Stations, be sure to specify Hood Rubber Tile Flooring. Its harmonizing colors enhance the beauty and *design* of every studio . . . its resiliency means all-important *quiet* and *comfort* . . . and believe me, it will last a *lifetime!*”

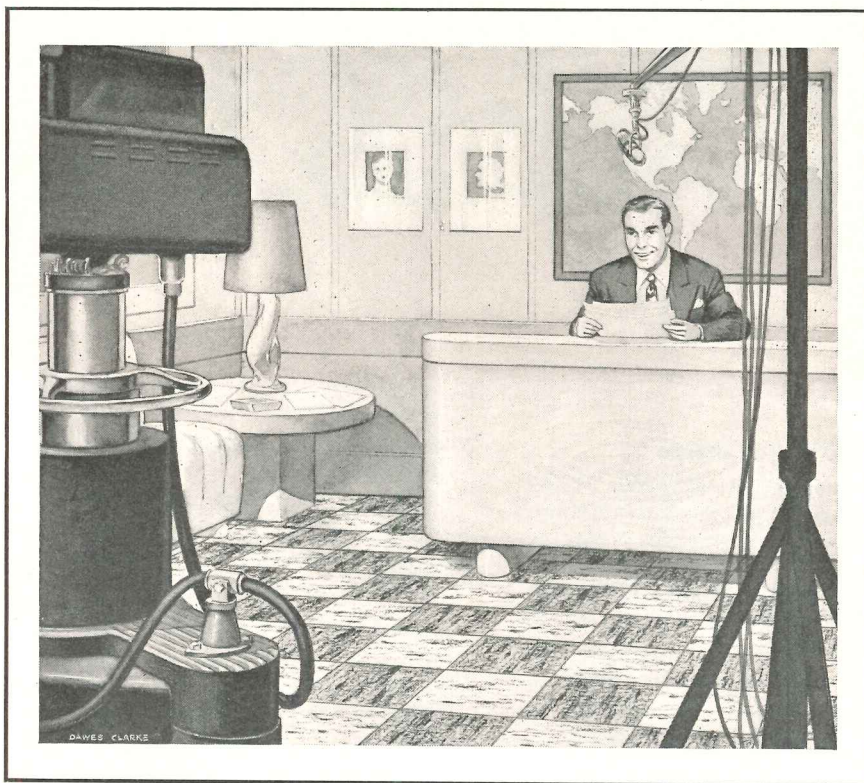

Yes, in TV Stations (recently completed WBZ Radio and Television Center, Boston), hospitals, schools, homes, wherever better flooring is needed, Hood Rubber Tile has long been the choice of leading architects and designers. Hood's exclusive *Super-*

*Density* eliminates dirt-catching pores making maintenance easier . . . this same feature means longer life, and the wide color variety means added charm and beauty for every interior. For complete information, see Sweet's or write for full color catalog today.

**HOOD**  
**RUBBER TILE**

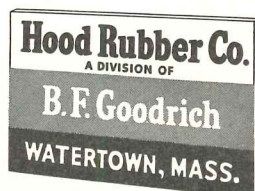

**HOOD**  
**ASPHALT TILE**

housing agency for enforcement of current FHA standards of construction. He observed: “What's the good of having requirements if the speculative builder gets away with murder and the buyer finds that maintenance and upkeep costs are almost equal to his capital investment?”

- Spokesmen for the C.I.O., testifying on the housing bill in the House, said national defense officials are preparing to give serious consideration to the Reuther Plan. Walter Reuther, chairman of the C.I.O. housing committee, recently proposed to President Truman and to Congress that surplus war plane manufacturing plants be converted to the output of prefabricated housing and held in a stand-by condition for the production of armaments in event of emergency.

- School construction would be greatly stimulated under terms of a new bill introduced by Senator John Bricker (Ohio). It would authorize \$250 million in the next fiscal year for construction of public schools and \$3 million for surveys and planning, the money to be apportioned to states in the ratio that their school populations compare to the entire school population of the country. The Federal Security Agency would administer such a program.

- New Committees on Waivers and Compromise are being set up in regional Veterans Administration offices to rule on the handling of veterans' debts arising from defaulted home loans. Debts involved would be the position of the loan guarantee that VA had to pay the lender after foreclosure. Nearly 1.5 million ex-servicemen have secured homes under the GI Bill of Rights.

- The American Road Builders' Association estimates that programs of the 48 states and the District of Columbia will call for construction of 34,271 miles of state and federal aid highways in 1949. Estimated cost of construction for the work will be \$1,265,692,000.

- Another antitrust suit was added to the fast-growing list of Justice Department moves in the construction field. In federal court in Detroit, the Besser Mfg. Co., its president Jesse Besser, and a subsidiary firm, all engaged in the manufacture of concrete block machinery, were charged with monopolizing interstate trade and commerce. Said

(Continued on page 172)

Remember this dependable source of supply



RESIDENTIAL

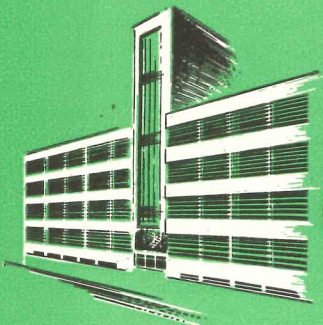
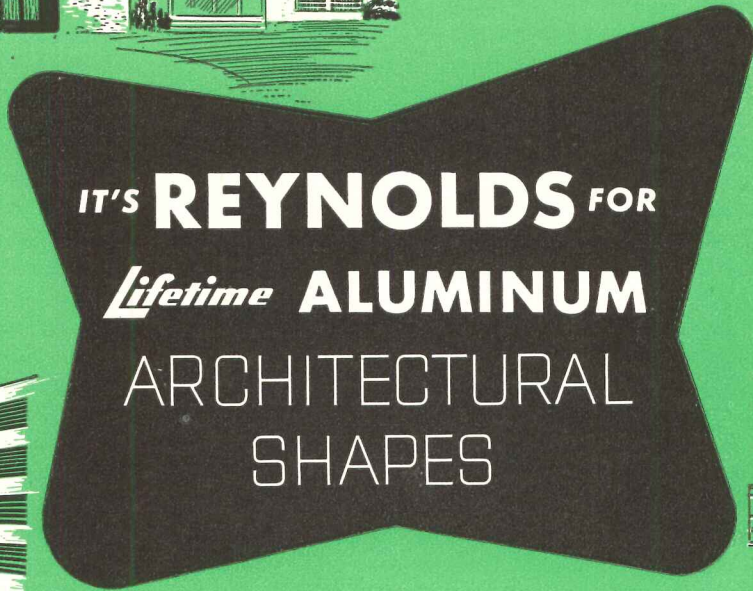

INDUSTRIAL



COMMERCIAL

**EXTERIOR APPLICATION**

- |                 |              |
|-----------------|--------------|
| Doors           | Sign Letters |
| Jambs           | Awnings      |
| Thresholds      | Spandrels    |
| Transoms        | Copings      |
| Vestibules      | Windows      |
| Revolving Doors | Window Sills |
| Marquees        | Facings      |
| Store Fronts    | Flagpoles    |
| Tablets, Signs  | Wall Facings |

**INTERIOR APPLICATION**

- |                 |                        |
|-----------------|------------------------|
| Terrazzo Strips | Elevator Doors, Cabs   |
| Bases           | Escalator Balustrading |
| Doors           | Decorative Trim        |
| Jambs           | Pilasters              |
| Thresholds      | Showcase Mouldings     |
| Railings        |                        |

**Warehoused in your area for prompt delivery**

● A new, modern line of architectural shapes made of Reynolds *Lifetime* Aluminum is now available to architects and builders. It's a complete line—containing more than 65 standard shapes—created only after a careful survey of your current design and building needs. Most of these bright, light, enduring aluminum shapes are warehoused from coast to coast for prompt delivery. In addition, Reynolds is prepared to quote on special alumi-

num shapes of your design.

For complete details call nearest Reynolds Office, listed under "Aluminum" in your classified telephone directory, or write to the address below.

**Send for this folio**

Engineering drawings of all standard shapes in a convenient folder. Can be used for direct tracing. Write to Reynolds Metals Company, Aluminum Division, 2572 South Third Street, Louisville 1, Ky.

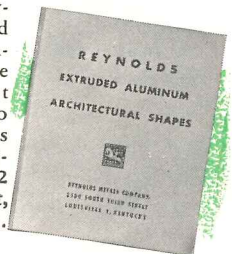

REYNOLDS METALS COMPANY, Aluminum Division, Louisville 1, Ky.

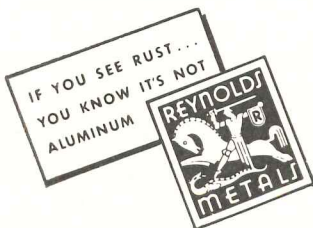

**REYNOLDS**  
*Lifetime* **ALUMINUM**

THE COMPLETE ALUMINUM SERVICE FROM BASE METAL TO FINISHED PARTS

## LETTERS TO THE EDITOR

---

### HIDDEN TALENT?

Editor:

First, I would like to congratulate you for conceiving the excellent idea of "Revelation by Competition" and also on the very handsome presentation of its results, which, indeed, reveal not only the quite apparent talent of many of the competitors, but are especially revealing in the professional design leadership and its influence on the younger generation.

I have read and studied your presentation with profound interest and I hope that you will find it in order if, in a frank and I trust constructive manner, I acquaint you with my reactions, which might or might not echo the reactions of others in our profession.

What puzzles me most are the principles which guided the jury in its judgment. I believe that one way to clarify the issue is to ask the jury to answer some of the questions arising in my mind while studying the published drawings.

In premiating the three designs, did not the jury also premiate the principle of designing from the outside in?

How can the winning design be excellent if it negates practically every single function which the structure is supposed to house?

How can a control office function from a mezzanine?

How can an inaccessible wardrobe in conflict with traffic to toilets and office, function?

How could you overcome the noise and sound problems and interferences with eight-foot partitions open above?

How can you control the light-glare and heat problems arising out of the glass walls in an economical way, etc. etc.?

One could go on with innumerable similar questions, the defects in the winning designs being so obvious and so general.

Did not the jury premiate just a "stage setting," a "décor," or a "sculpture," which has no relation to the human, simple and matter-of-fact functions of an American community center?

Wasn't the approach just the opposite to the logical approach of complete humility, searching for the simplest, most economical, direct, honest and natural solution, hoping as a reward for

this attitude, to create something with lasting values and therefore beautiful?

Aren't the three premiated solutions rather eclectic attempts to do something striking, extraordinary, original, from precedents created to excite the pampered and degenerate palates of just a few?

Will not the judgment leave the younger generation even more confused than it was up to now as to the validity of the doctrines as taught in schools and practiced in judging competitions, upon entering the actual practice of the profession and its realities?

Does the jury realize the gravity of their responsibility in acting as "arbiters of beauty" and "experts of approach" and the amount of harm they might cause by actions prompted by other considerations than those of an impersonal and detached attitude?

ANTONIN RAYMOND, A.I.A.

Editor:

I have carefully studied the winning entries in the Hidden Talent Competition as published in last month's RECORD and as exhibited in The Museum of Modern Art. The interpretation of the modern architectural concept thus offered by capable judges, has left me completely confused. . . . [Here followed detailed criticism of winning designs. Ed.]

In general, the winning solutions cast serious aspersions on the essence of modern architecture. They prominently indicate that the modern concept, as interpreted by most, is no true concept of ideals at all, but rather stems from the exploitation of a commercial fad. The intention is to build a heap of esthetics with the terms in vogue, and place humans in it, to live. The point of error is that the esthetic interest dominates and overwhelms the logical architectural solution instead of resulting as an outgrowth of the correct combination of the required structural materials.

It seems obvious to me that the competition has not succeeded in discovering any hidden talent, but rather has uncovered the fallacies and confusion prevalent today in the field of architecture. The realization of this and the consequences may very well help to stir these misconceived ideologies out of

their utopian slumber and onto the road of logical architectural thinking. Thus only with this negative result has the competition served any significant purpose.

HERBERT SHALAT

Student, Cooper Union, N. Y.

Editor:

The publications of the drawings for the Hidden Talent Competition are indeed revealing — yes, revealing to the extent that even the distinguished members of the jury seem to be in a state of mental confusion and uncertainty in their architectural thinking. . . . [Here followed detailed comments on the Report of the Jury. Ed.]

While the jury is the only group in a position to state that "most of the designs were humdrum in the extreme and the quantity of gold which they unearthed seemed shockingly disproportionate to the dross," it is evident that the selection of the premiated designs by so eminent a jury does not really add to the clarity of thinking in the field of architectural endeavor as many of us had hoped it would, but rather has that judgment added to the confusion and chaos. We might well ask, "what do we want" and "how are we going to achieve what is wanted," and "where are we headed for in the field of architectural design."

To ask these questions is not to be pessimistic about the future of architectural achievement, but rather is it to stress the fact that we are striving, groping, yearning for a new day in architecture. That day has not arrived yet; and perhaps it is fortunate that it has not. The whole atmosphere is surcharged with the spirit of experimentation, restlessness, and doubt. Since that is the kind of a world we are living in, the reflection of these uncertainties in our architectural thinking is neither surprising nor inconsistent.

Whether or not the results of this competition will enable us to "take stock of the current approaches and emphasis with an eye to clarifying our own thinking and establishing a new and reaffirmed direction" remains to be seen. Although the deliberations of so illustrious a jury, as evidenced in the selection of the premiated designs, have not clarified the architectural atmosphere very much, it is to be hoped that similar competitions will be conducted more frequently in the future than in the past.

P. M. TORRACA

Associate Professor of Architecture  
University of Florida



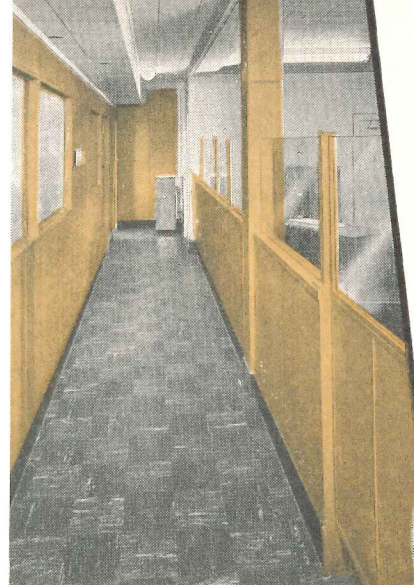

*The HICKS CHEVROLET*  
 122 NORTH YORK ROAD • TOWSON & HANOVER

Gentlemen:  
 We are very proud of the installation in our offices of M-P METLWAL.

Aside from being outstanding in appearance, we have in our METLWAL partitions a real value in that it is possible to move, enlarge or replace any of our present setup on a very economical basis; the maintenance on METLWAL partitioning is practically nil and it is simple to keep them clean for a long period of time rather than to be continuously redecorating.

Very truly yours,  
 THE HICKS CHEVROLET, INC.

*R. F. Hicks*  
 R. F. Hicks



Mr. R. F. Hicks, Pres.  
 The Hicks Chevrolet Inc.,  
 Towson 4, Maryland.



**EXAMPLE: The Hicks Chevrolet Inc., Towson, Maryland\***

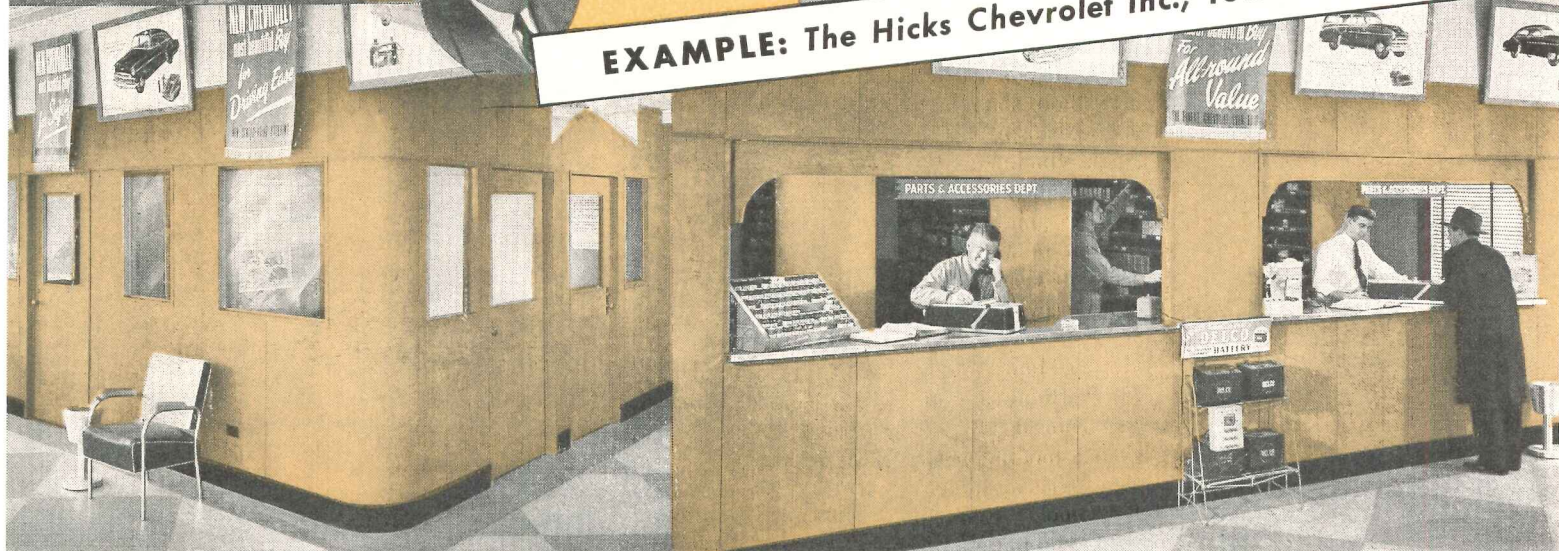

\* This is one of many recent automobile showroom installations.

## Metlwal *Eye-appeal* puts more *Buy-appeal* in any business!

WHETHER it's shoes, shirts or sedans your clients are selling . . . *Metlwal* Partitions and Paneling provide a smart, good-looking sales setting that helps put customers in a buying mood! *Metlwals* alone combine rich beauty, easy maintenance and rapid installation. Factory-finished in distinctive wood grain reproductions, or baked enamel, they will not reflect harsh, metallic light . . . will not chip, crack, craze or rust.

*Metlwals* are installed easily and quickly by erection crews. All parts and panels can be cut to fit on the job. No need for plaster in new construction. No filler boards or patchwork. Only a few standard parts from

warehouse stock. And Martin-Parry's modern production facilities, in our huge Toledo plant, insure uniform, interchangeable panels . . . long-wearing installations that hold maintenance costs to a new low!

**WRITE TODAY** for your free copy of our latest catalog, A-6, containing

*Metlwal* specifications, drawings and installation photographs. See how *Metlwal* can help you plan beautiful interiors for offices, factories, sales rooms and institutions. Address: Martin-Parry Corporation, Toledo 1, Ohio.



**69 Years of service**

MARTIN PARRY  
**METLWALS**  
 ALL-FLUSH PANELING MOVABLE PARTITIONS  
 ENGINEERING AND ERECTING SERVICE AND WAREHOUSE STOCKS FROM COAST-TO-COAST

# CONSTRUCTION COST INDEXES — Labor and Materials

United States average 1926-1929=100

Presented by Clyde Shute, manager, Statistical and Research Division, F. W. Dodge Corporation, from data compiled by E. H. Boeckh & Associates, Inc.

## NEW YORK

## ATLANTA

Period	Residential		Apts., Hotels, Office Bldgs. Brick and Concr.	Commercial and Factory Buildings		Residential		Apts., Hotels, Office Bldgs. Brick and Concr.	Commercial and Factory Buildings	
	Brick	Frame		Brick and Concr.	Brick and Steel	Brick	Frame		Brick and Concr.	Brick and Steel
1925	121.5	122.8	111.4	113.3	110.3	86.4	85.0	88.6	92.5	83.4
1930	127.0	126.7	124.1	128.0	123.6	82.1	80.9	84.5	86.1	83.6
1935	93.8	91.3	104.7	108.5	105.5	72.3	67.9	84.0	87.1	85.1
1939	123.5	122.4	130.7	133.4	130.1	86.3	83.1	95.1	97.4	94.7
1940	126.3	125.1	132.2	135.1	131.4	91.0	89.0	96.9	98.5	97.5
1941	134.5	135.1	135.1	137.2	134.5	97.5	96.1	99.9	101.4	100.8
1942	139.1	140.7	137.9	139.3	137.1	102.8	102.5	104.4	104.9	105.1
1943	142.5	144.5	140.2	141.7	139.0	109.2	109.8	108.5	108.1	108.7
1944	153.1	154.3	149.6	152.6	149.6	123.2	124.5	117.3	117.2	118.2
1945	160.5	161.7	156.3	158.0	155.4	132.1	133.9	132.2	122.8	123.3
1946	181.8	182.4	177.2	179.0	174.8	148.1	149.2	136.8	136.4	135.1
1947	219.3	222.0	207.6	207.5	203.8	180.4	184.0	158.1	157.1	158.0
Jan. 1949	251.8	250.6	246.6	251.2	244.8	193.6	194.6	179.7	185.3	183.2
Feb. 1949	252.0	250.8	246.9	251.4	245.0	197.8*	198.8†	184.9**	185.5	183.4
Mar. 1949	252.3	249.7	247.9	252.6	246.3	196.5	197.3	183.8	184.9	180.3
	% increase over 1939					% increase over 1939				
Mar. 1949	104.3	104.0	89.7	89.4	89.3	127.7	137.4	93.3	89.8	90.4

Period	ST. LOUIS		Apts., Hotels, Office Bldgs. Brick and Concr.	Commercial and Factory Buildings		SAN FRANCISCO		Apts., Hotels, Office Bldgs. Brick and Concr.	Commercial and Factory Buildings	
	Brick	Frame		Brick and Concr.	Brick and Steel	Brick	Frame		Brick and Concr.	Brick and Steel
1925	118.6	118.4	116.3	118.1	114.4	91.0	86.5	99.5	102.1	98.0
1930	108.9	108.3	112.4	115.3	111.3	90.8	86.8	100.4	104.9	100.4
1935	95.1	90.1	104.1	108.3	105.4	89.5	84.5	96.4	103.7	99.7
1939	110.2	107.0	118.7	119.8	119.0	105.6	99.3	117.4	121.9	116.5
1940	112.6	110.1	119.3	120.3	119.4	106.4	101.2	116.3	120.1	115.5
1941	118.8	118.0	121.2	121.7	122.2	116.3	112.9	120.5	123.4	124.3
1942	124.5	123.3	126.9	128.6	126.9	123.6	120.1	127.5	129.3	130.8
1943	128.2	126.4	131.2	133.3	130.3	131.3	127.7	133.2	136.6	136.3
1944	138.4	138.4	135.7	136.7	136.6	139.4	137.1	139.4	142.0	142.4
1945	152.8	152.3	146.2	148.5	145.6	146.2	144.3	144.5	146.8	147.9
1946	167.1	167.4	159.1	161.1	158.1	159.7	157.5	157.9	159.3	160.0
1947	202.4	203.8	183.9	184.2	184.0	193.1	191.6	183.7	186.8	186.9
Jan. 1949	227.1	228.1	214.3	217.5	214.2	218.4	214.1	214.9	221.3	217.9
Feb. 1949	227.3	228.3	214.7	217.8	214.7	218.6	214.3	215.2	221.5	218.1
Mar. 1949	225.9	226.6	214.6	217.7	214.7	217.2	212.5	214.9	221.3	217.7
	% increase over 1939					% increase over 1939				
Mar. 1949	105.0	111.8	80.8	81.7	80.4	105.7	114.0	83.0	81.5	86.7

The index numbers shown are for combined material and labor costs. The indexes for each separate type of construction relate to the United States average for 1926-29 for that particular type — considered 100.

Cost comparisons, as percentage differences for any particular type of construction, are possible between localities, or periods of time within the same city, by dividing the difference between the two index numbers by one of them; i.e.:

index for city A = 110  
index for city B = 95  
(both indexes must be for the same type of construction).

Then: costs in A are approximately 16 per cent higher than in B.

$$\frac{110-95}{95} = 0.158$$

Conversely: costs in B are approximately 14 per cent lower than in A.

$$\frac{110-95}{110} = 0.136$$

Cost comparisons cannot be made between different types of construction because the index numbers for each type relate to a different U. S. average for 1926-29.

Material prices and wage rates used in the current indexes make no allowance for payments in excess of published list prices, thus indexes reflect minimum costs and not necessarily actual costs.

These index numbers will appear whenever changes are significant.

\* Erroneously reported in May as 193.8, giving a % increase over 1939 of 124.6% instead of 129.2%.  
† Erroneously reported in May as 194.8, giving a % increase over 1939 of 134.4% instead of 139.2%.  
\*\* Erroneously reported in May as 179.9, giving a % increase over 1939 of 89.2% instead of 94.4%.

**RIGHT...**  
*from the Start!*

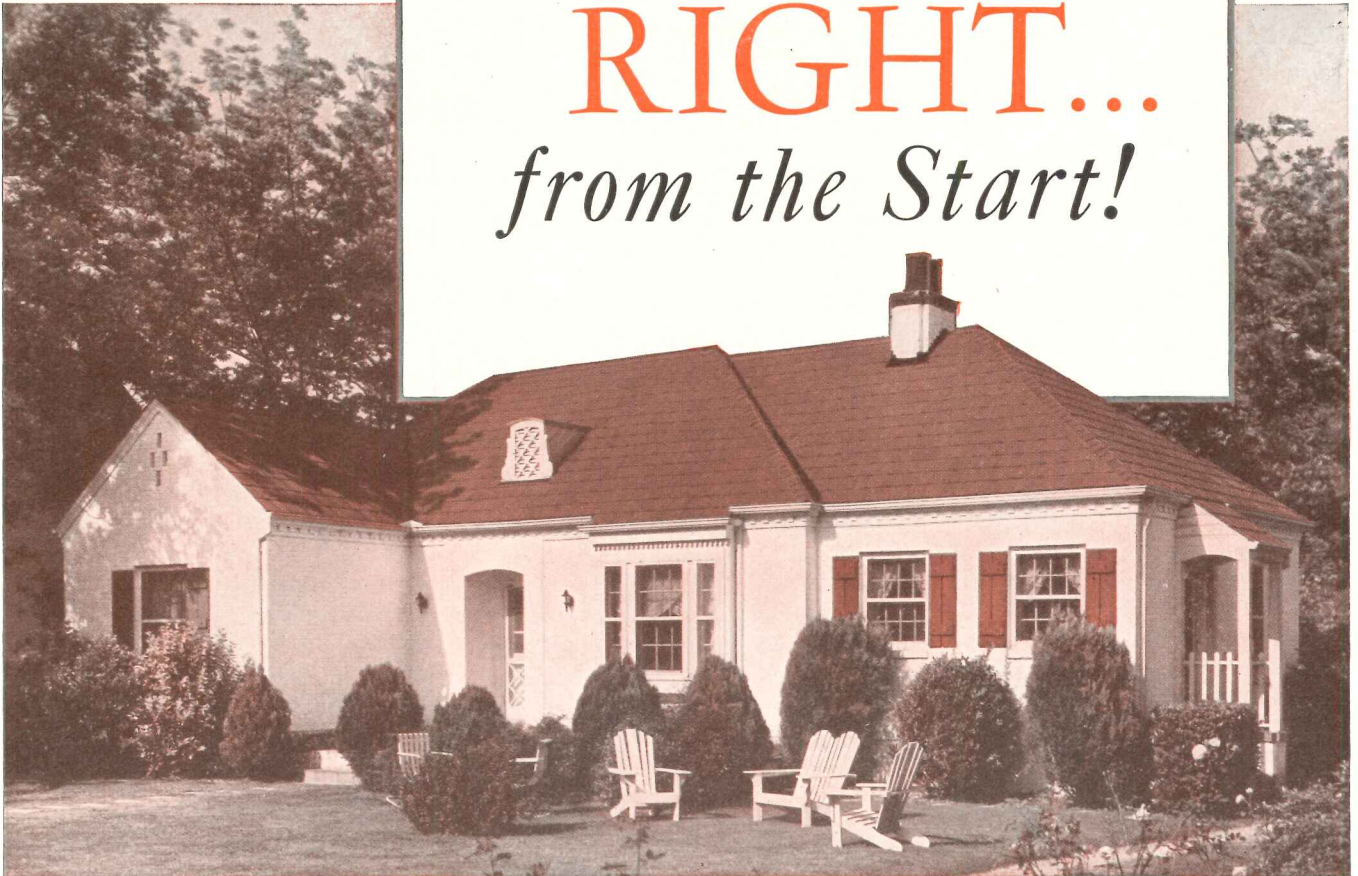

ARCHITECTS: Sherlock, Smith and Adams, Montgomery, Alabama

*At Home!*  
*With any style... any size house!*



**FREE**—This new booklet, "Good Application Makes a Good Roof Better". A 24-page booklet, prepared by the Engineering Committee to summarize the latest recommended application practices. A valuable check list of details to watch in job supervision. Copies available from member companies or direct.

**D**esign is much more than lines and planes—it is materials, depth, texture, pattern and color. And design is served best when all of these elements can be known and blended—right from the start. One reason why asphalt shingles blend so well with modern design is that many architects approach their design problem with these adaptable shingles in mind.

Actually, of course, asphalt shingles fit the traditional as perfectly as the contemporary. They are at home with any style, any

size house—but most especially so when they have been made to "feel" at home on the designer's board.

There are many practical advantages to recommend asphalt shingles in current residential building—such as economy, low cost application, fire-resistance, durability.

But with these must be included the important design advantage of adaptability in pattern, texture and color that makes them "belong" with today's styling of either traditional or contemporary.

**ASPHALT ROOFING INDUSTRY BUREAU • 2 West 45th St., New York 19, New York**

SPONSORED BY 28 LEADING MANUFACTURERS OF ASPHALT SHINGLES...SIDINGS...ROLL AND BUILT-UP ROOFINGS

asphalt

**SHINGLES**

*Construction's Biggest Dollar's Worth*

# REQUIRED READING

## STEEL DESIGN

*Design of Steel Buildings, Third Edition.* By Harold D. Hauf and Henry A. Pfisterer. John Wiley & Sons, Inc. (440 Fourth Ave., New York 16), 1949. 5¾ by 8¾ in. x+280 pp., illus. \$5.00.

For the architect who must (or likes to) figure his own structural steel, or wishes to review what he has forgotten and to bring himself up to date; and for text book use by students, this third revised edition is a clear and concise guide.

The purpose of this book, as stated in the preface to the first edition, is to present the general principles of structural design as applied to the more common types of buildings such as apartment houses, offices and school and other institutional buildings. The general scope and method of presentation of the earlier editions have been retained in this revision, but the material on welded construction has been greatly expanded and now forms a separate chapter. In addition to a general discussion of welded framing connections, the application of welding to the design of plate girders and roof trusses is treated in detail.

All the examples in the text have been revised and made consistent with structural shapes now available.

The chapter on the design of beams has been rewritten extensively, and a more detailed treatment of the use of safe load tables included. As an aid to persons studying outside the classroom, answers to certain selected exercise problems have been given in an appendix. All exercise problems are new.

## UNIVERSITY LIBRARIES

*Planning the University Library Building.* Edited by John E. Burchard, Charles W. David and Julian P. Boyd. Princeton University Press (Princeton, N. J.), 1949. 5½ by 8¾ in. xvii+145 pp., illus. with plans. \$2.50.

No architect should think of planning a university library building without a thorough reading of this meaty, informative and stimulating volume. And it should be kept at hand for constant reference as each of the perplexing problems comes up for solution in the process of producing an integrated design. In it is a wealth of vicarious experience that will prove invaluable. It is a comprehensive study, logically presented, that takes up in order the place and functions of the library, the problems of policy and administration, desirable space arrangements, stack arrangement and construc-

tion, air conditioning, modern illumination, technological problems and trends, the librarian and the architect, and finally provides an excellent bibliographical essay. Diagrammatic plans of fourteen libraries are included.

Here is an exchange of the experience and ideas of a nationwide group of librarians, architects, and engineers. These members of the Cooperative Committee on Library Planning, which was financed by the Rockefeller Foundation, consider both practical matters of physical construction and vital factors of policy and administration.

The editors, who have here summarized the Committee's findings, consider every aspect of library planning. One of the most important and often neglected questions — how to get architects, librarians and administrators working as a team — receives strong emphasis here. The latest and most ingenious methods of illumination and air conditioning are discussed. Such ideas as windowless libraries and all-glass walls come up for appraisal. The editors consider how to plan a building for flexibility and growth, the merits of functional versus traditional architecture, and many other problems. In effect, therefore, this book provides a check-list of all matters to be considered by those planning to build or wishing to improve a library.

## SIMPLE STRUCTURAL PROBLEMS

*Elementary Structural Problems in Steel and Timber, Third Edition.* By C. R. Young and C. F. Morrison. John Wiley & Sons, Inc. (440 Fourth Ave., New York 16), 1949. 6 by 9¼ in. xiii+329 pp., diagrams. \$4.50.

This book is not intended to be a handbook or text book, or for use in routine office practice. It is written for the man who wants to test the knowledge of design theory he has already acquired. Problems involving the design of beams, girders, trusses, and other timber and steel structures are presented and solved in detail, so that the reader can see exactly how such problems are handled in industry. For readers who want background information on any problem, the authors have included references to the standard books on structural theory.

The most extensive revisions in the third edition have been made in Part II, "Timber Structures," which has been completely rewritten and expanded 25 per cent. As a result, Part II now gives

a complete coverage of modern timber engineering. Recent developments in ring-connected construction are covered in several chapters, while Chapter 16 shows the design of a single, simple, segmental, glued, laminated wood arch of 48-ft. span. Chapter 16 was written by Professor C. F. Morrison, who did special research work on glued, laminated timber members for the Forest Products Laboratory of Canada in 1944.

## TOWARD BETTER CHURCHES

*The Church Builder.* By Elbert M. Conover. The Interdenominational Bureau of Architecture (297 Fourth Ave., New York 10, N. Y.) 1948. 6 by 9¼ in. 192 pp., illus. \$2.75.

It always pays an architect to know what his client is thinking about, and what advice he has already received from various sources. This foreknowledge of what the client has been exposed to in the way of example and advice, his preconditioning so to speak, makes the architect's task of determining requirements, present solutions, and dealing with prejudices or preconceived ideas, much easier than would otherwise be the case.

Undoubtedly pastors and church boards and building committees of Protestant churches will get much, or most, of their information about church building from this comprehensive book by Elbert M. Conover. Mr. Conover is an authority on church building problems, and these problems are many. He writes from 25 years full of experience in church building guidance as he is the director of the Interdenominational Bureau of Architecture. He realizes fully that the architect is an essential factor in successful church building, and he describes for the layman what is involved in architectural service, and the ethics involved. This will undoubtedly be enlightening to church building committees and is a distinct service to the architectural profession.

The author also understands church building committees, for he says:

"Too often, the architect is invited to church meetings where he is bombarded with irrelevant questions and instructions, criticized for his 'large' fee, and forced to listen to arguments between the church people present on various features of the building program.

"Before the church decides on the floor plan, some trustees will persist in discussing the pitch of the roof or the type of heating. Brother architect goes home with a headache, manages to remain cheerful the next day when a com-

(Continued on page 30)

*Now at low cost you can get durable Colored Concrete Floors and Colored Sidewalks*

*Typical automobile showroom floor of Colorundum provides fine car setting.*

*Indoors and outdoors on new work or when replacing old floors*

*Colorundum Black non-glare sidewalks heighten beauty of Art Gallery facade.*

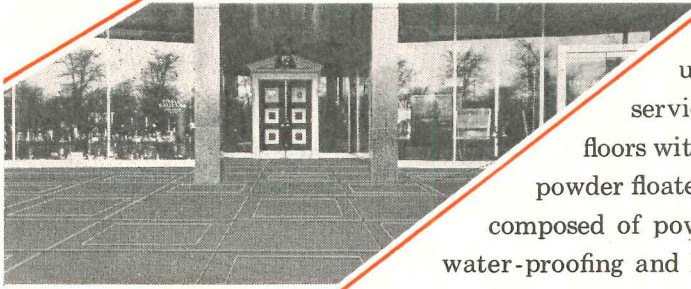
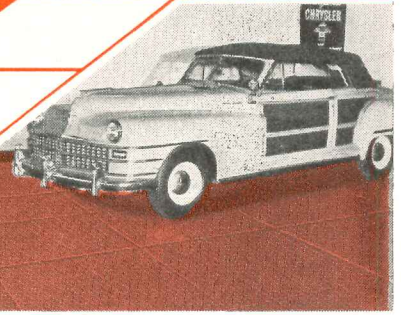

For colored concrete floors and colored sidewalks use Colorundum. For hotels, stores, hospitals, service stations and factories you get bright, colorful floors with an armor plate surface. Colorundum is a dry powder floated and trowelled into the floor topping. It is composed of powerful coloring agents, fused aggregates, water-proofing and hardening elements and cementitious binders. The colorful non-slip, dense surface is an ideal flooring for indoors or outdoors . . . on new work or when replacing old floors. Write for further information.

Also Available in:  
Red • Green • Black  
Grey • Brown

**FOR COLORED CONCRETE FLOORS & SIDEWALKS**

# COLORUNDUM

**A. C. HORN COMPANY, INC.**

*manufacturers of materials for building maintenance and construction*

10th STREET & 44th AVENUE • LONG ISLAND CITY 1, N. Y.

HOUSTON • CHICAGO • LOS ANGELES • SAN FRANCISCO • TORONTO

Subsidiary of



Chemical Corporation

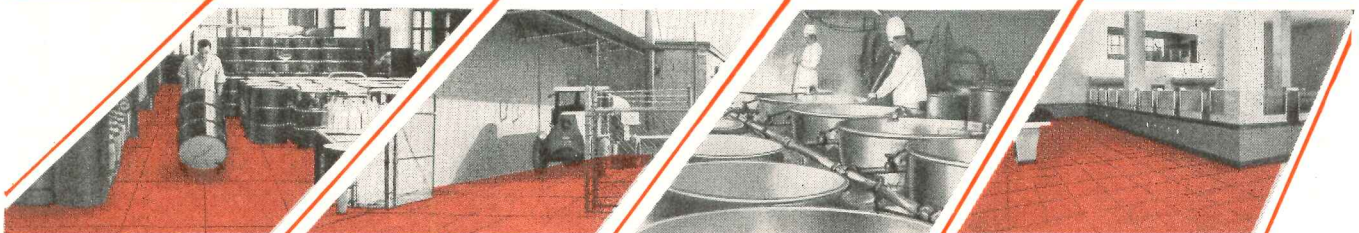

**PLANTS**

**DRIVEWAYS**

**KITCHENS**

**BANKS**



**WALKS**

**HOSPITALS**

**LOBBIES**

**NEW  
OPPORTUNITIES  
FOR MODERN DESIGN**

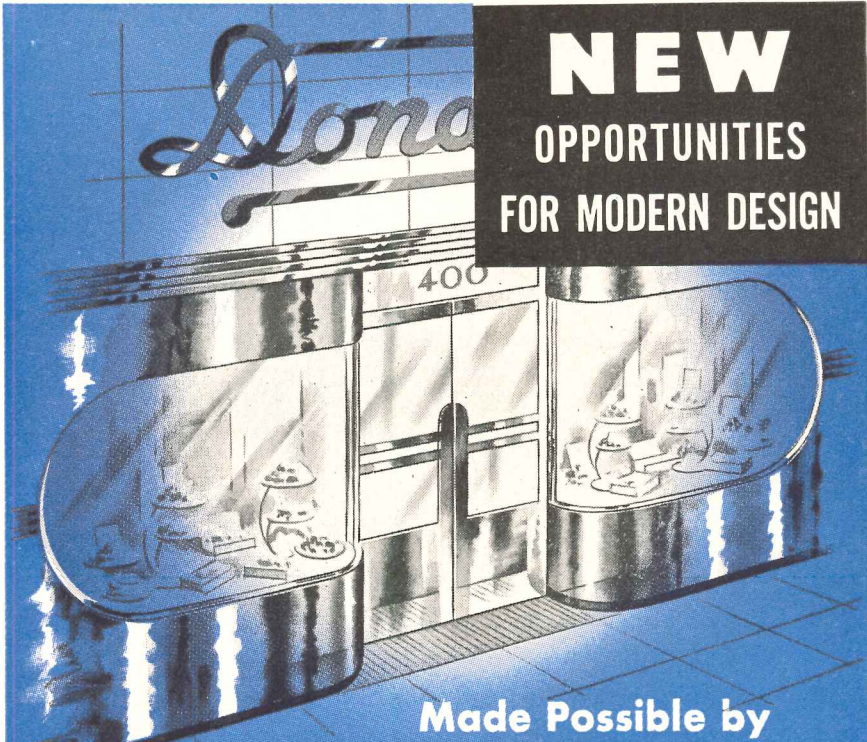

Made Possible by  
**PERMACLAD**  
STAINLESS CLAD STEEL

**Corrosion Resistant!**

**Easily Formed or Deep Drawn!**

Now architects can design beautiful, high luster doors, panels, building facades, store fronts and ornaments, and be confident that they will retain their mirror-like finish almost forever. Permaclad, the new Stainless Clad Steel has made this possible.

Permaclad combines the surface characteristics of Stainless Steel with the forming qualities of Carbon Steel providing corrosion resistance at decreased cost.

Reduction of weight is possible through the use of AW Dynalloy, high strength, low alloy steel as a backing. When lighter sections are used usually substantial savings can be effected.

Get complete information and literature about this wonderful new material by writing or mailing the coupon below.

The Finer  
The Finish The  
Finer The Product  
For The Finest Finish  
Use  
PERMACLAD



**PERMACLAD**  
STAINLESS CLAD STEEL

A Product of **ALAN WOOD STEEL COMPANY**

Conshohocken, Pa., Dept. P20

Gentlemen: Please send me more information and Free literature about Permaclad

Name \_\_\_\_\_ Title \_\_\_\_\_

Company \_\_\_\_\_

City \_\_\_\_\_ State \_\_\_\_\_

**OTHER PRODUCTS:** AW Super Grip, Abrasive Floor Plate • AW Super-Diamond Floor Plate • Billets • Plates • Sheets (alloy and special grades).

**REQUIRED READING**

(Continued from page 28)

mittee comes, unannounced, to talk about the kitchen, not waiting to give their instructions in writing through the planning committee."

Even the experienced architect will gain from this volume a new insight into the requirements of a really functioning church.

Most of the illustrations quite naturally depict churches or features of churches in traditional styles. The author has evidently tried to choose the best "modern" or contemporary designs that he could find, as well as traditional examples. However, as one peruses the illustrations, one must conclude that there is a great opportunity for design talent in the ecclesiastical field.

This book will not only help pastors and church building committees in understanding their own problem and the architect's, but will also enable architects to understand better the problems of the church authorities. The book would have been even more useful as a reference work if it had an index.

**SAFER HOMES**

*Safety for the Household.* U. S. Dept. of Commerce and the National Bureau of Standards. Circular 463. U. S. Government Printing Office (Washington, D. C.) 1947. 6 by 9 1/8 in. x+190 pp. illus. \$.75.

The principal hazards to safety in the home, and the means for eliminating or reducing them are discussed in detail in the new edition of *Safety for the Household*. While written mainly for the average present-day household, this booklet provides information that is also of value in the design and construction and safe operation of schools, hotels, hospitals, stores, and industrial plants.

Chapters on gas, building construction, refrigerants, fire prevention, heating equipment, plumbing, fire extinguishers, electrical equipment, and other special items have been prepared by qualified specialists from the various sections of the Bureau dealing with these particular subjects. The chapter on suggestions for building a home and the discussions of hazards in the use of hand tools and machinery will be found especially helpful. In recent years new trends in home design, new household equipment, and modern toys have brought new sources of accidents. This book is an effort to keep pace with the hazards introduced by these developments.

(Reviews continued on page 212)

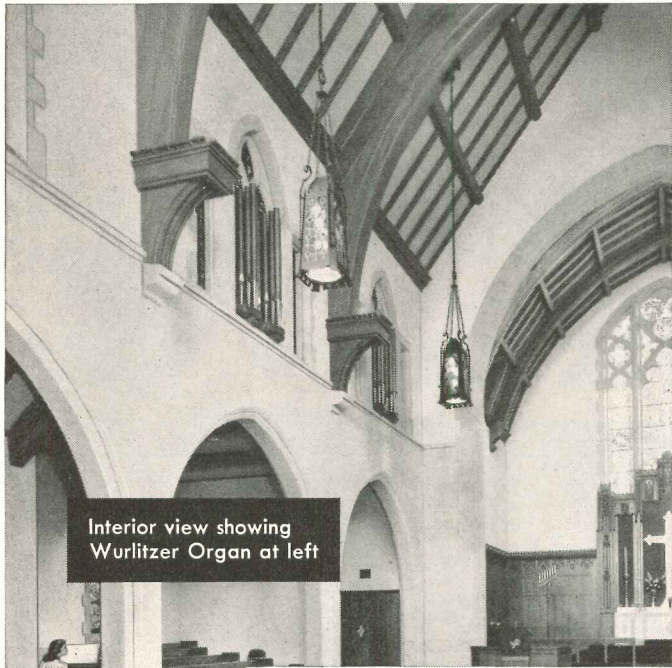

Interior view showing Wurlitzer Organ at left

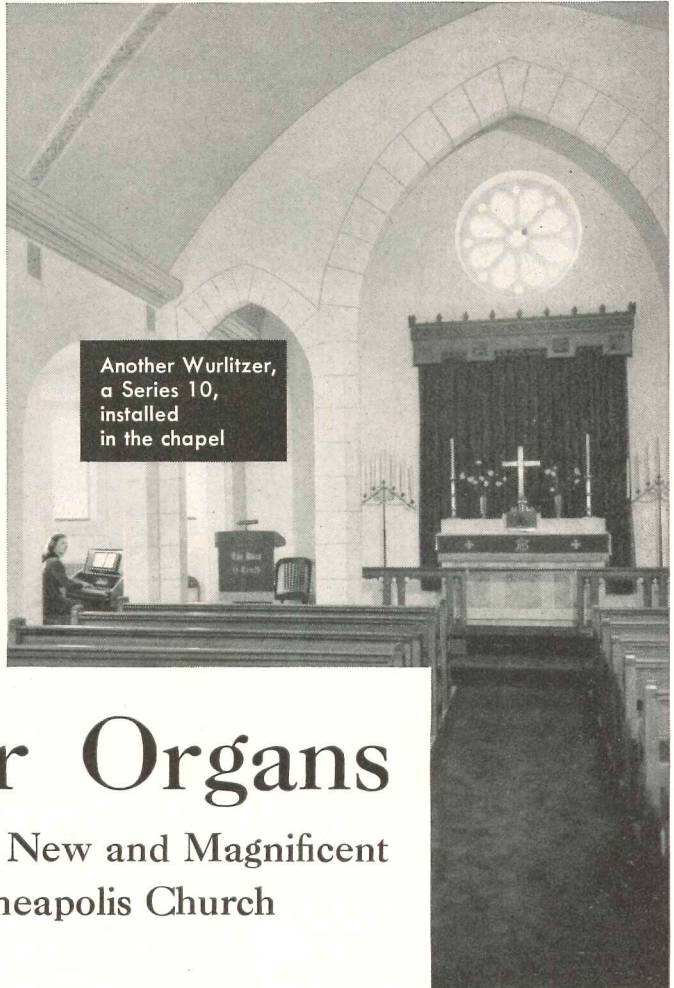

Another Wurlitzer, a Series 10, installed in the chapel

# Wurlitzer Organs

Chosen for New and Magnificent Minneapolis Church

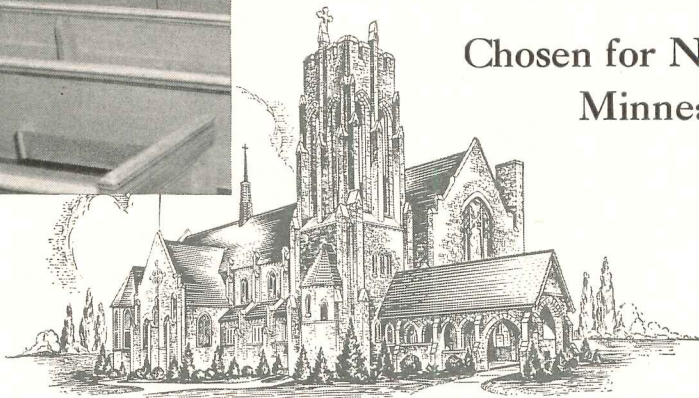

*Mt. Olivet Lutheran Church, Minneapolis, Minnesota*

Even though the original design of this beautiful new church included provisions for a large and costly pipe organ, Wurlitzer Electronic Organs were selected for the final installation. This was because it was found that traditionally correct organ music for the church proper, seating 1400 people, could be more than adequately provided by a two-manual Series 21 Wurlitzer Organ—*at great savings in cost.*

In addition, a single-manual Wurlitzer Series 10 was placed in the lovely chapel of the church. *And the combined costs of both Wurlitzers fell far below the estimates for the installation originally planned.*

To churches, schools and institutions, and to their architects and builders as well, Wurlitzer offers these specific advantages: 1. Two different two-manual organs, and two different single-

manual organs, specifically designed to meet the needs of *every* congregation, large or small. 2. Traditional organ tone—rich, full and true. 3. Important savings in space and construction costs. 4. Simplification of plans—simplicity of installation.

In any plans calling for organ installation, our own skilled technicians will be glad to work with you. May we send you complete information?



*The Wurlitzer Organ, Series 21. The same model installed in new Mt. Olivet Lutheran Church.*

## WURLITZER

WORLD'S LARGEST BUILDER OF ORGANS AND PIANOS  
UNDER ONE NAME

THE RUDOLPH WURLITZER COMPANY, ORGAN DIVISION, NORTH TONAWANDA, NEW YORK

# Fuel Consumption **CUT IN HALF**

with

## **ENTERPRISE** Burners

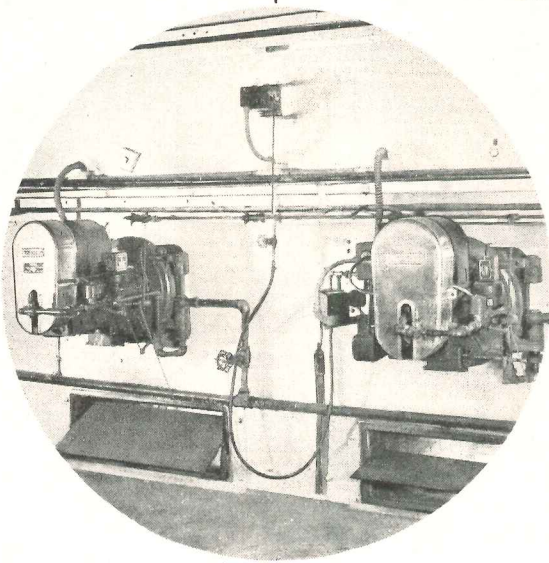

*Above view shows two Enterprise Size K2 300 HP full-automatic Burners, with gas-electric ignition and electronic controls, in service at New System Laundry. Installed by Enterprise Oil Burner Distributor E. A. Ponder, Portland, Oregon.*

Big fuel savings are always in store where Enterprise Oil Burners are installed to carry the heating load. Here at the New System Laundry in Portland, Oregon, the reconversion from obsolete hand-fired oil equipment has actually resulted in cutting fuel consumption in half!

But this is only part of the savings story. Mr. Warren C. James, Superintendent of Maintenance at the New System plant, reports: "There is no longer any time loss in starting the boilers and no more smoking. Modulating controls operate burners to perfection. Electronic controls provide the ultimate in protection, eliminating the need for full-time attendant in the boiler room. Constant, uninterrupted and economical service is the result, and a difficult problem of steam generation has been solved with the installation of these new, full automatic Enterprise Burners."

Enterprise Oil Burners, approved by Underwriters' Laboratories, Inc., are available in a wide range of industrial and automatic sizes. Gas-Oil combination burners are also furnished in standard sizes. For low-cost, high-efficiency heating, specify Enterprise. Write for full information.

*The Choice of Heating Experts*



*Specify*

## **ENTERPRISE** Burners

BURNER DIVISION OF ENTERPRISE ENGINE & FOUNDRY CO.  
18TH AND FLORIDA STS., SAN FRANCISCO 10, CALIFORNIA • DISTRIBUTORS IN PRINCIPAL CITIES



FOR BRIGHTER, MORE

*Efficient*

BATHROOMS

SET THE STAGE WITH . . .

GENUINE CLAY  
*tile*

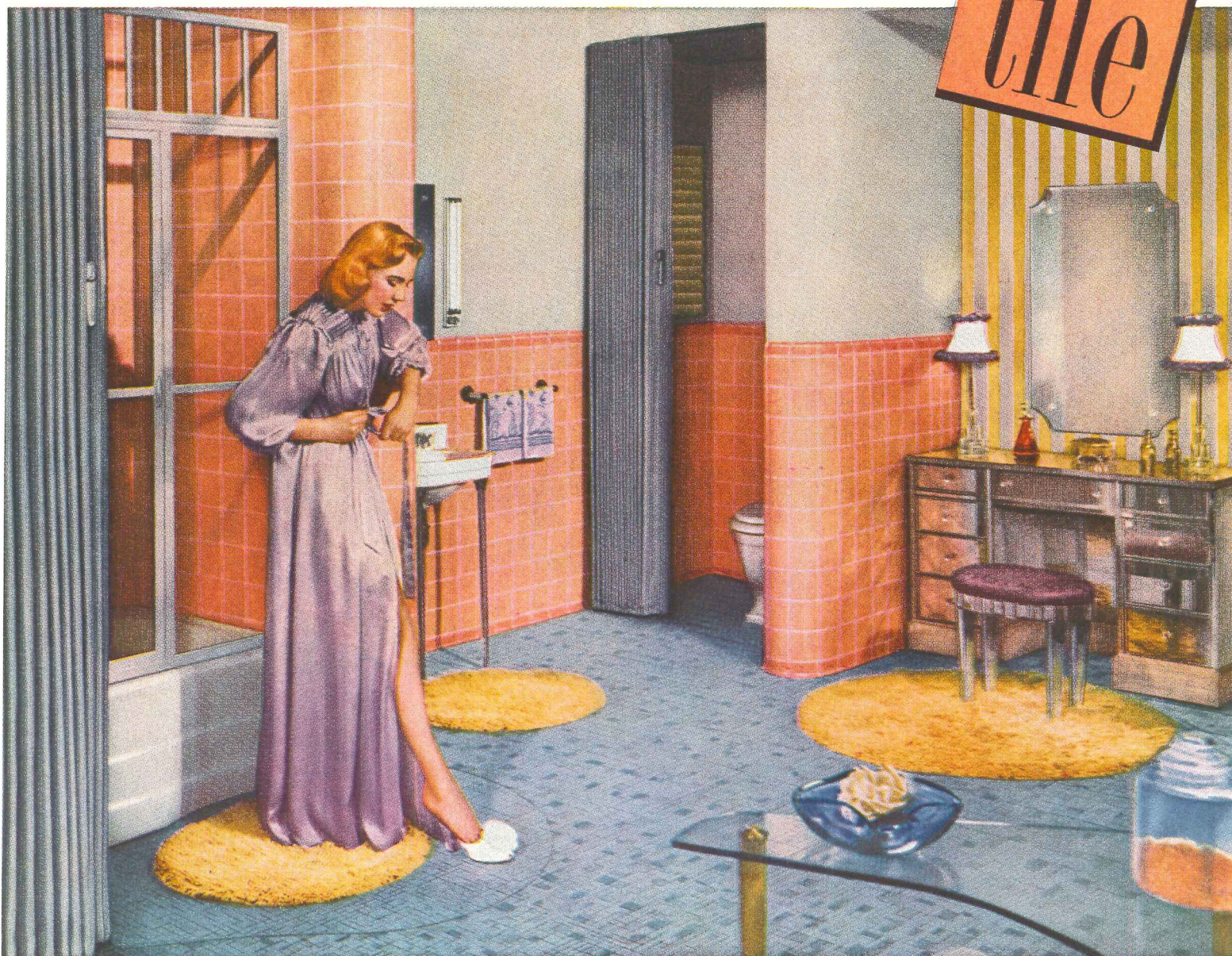

In this modern bathroom, clay tile sets the stage with a wall of sparkling color and an imaginative pattern of complementary colors on the floor. This is but one of countless ways in which tile is used today to enhance any decorative theme.

Yes, there's limitless flexibility of design with tile—*plus* all the other advantages that today's homemakers look for:

**Easy to clean** and keep clean because clay tile never needs waxing, polishing or refinishing.

**Colors won't fade** or darken because clay tile's beauty is *fired in* to resist water, acid and stains.

**Efficient** because tile keeps its spic-and-span appearance despite hard wear. Water rolls off without leaving stubborn, streaky blemishes.

**Long-range economy** because there are no recurring charges for maintenance or replacement. Only clay tile can insure this lifetime of loveliness.

For specific information regarding available types, sizes and colors, see *Sweets Architectural* or *A-E-C File*. THE TILE COUNCIL OF AMERICA, Room 3401: 10 East 40th Street, New York 16, New York. Room 433: 727 West Seventh Street, Los Angeles, California.

The Tile Council of America was formed in January, 1945 to provide a central source of information about floor and wall tile, and to sponsor research and development projects designed to increase the usefulness of tile in all types of private and public building.

**PARTICIPATING COMPANIES:** American Encaustic Tiling Company • Architectural Tiling Company, Inc. • Atlantic Tile Manufacturing Company • B. Mifflin Hood Company • Cambridge Tile Manufacturing Company • Carlyle Tile Company • General Tile Corp. • Gladding, McBean & Company • Mosaic Tile Co. • Murray Tile Company, Inc. • National Tile & Manufacturing Company • Olean Tile Company • Pacific Clay Products • Pacific Tile and Porcelain Co. • Pomona Tile Manufacturing Company • Robertson Manufacturing Company • Sparta Ceramic Company • Summitville Face Brick Company • United States Quarry Tile Company

**THE MODERN STYLE IS CLAY TILE**



**Open-Web Steel Joists in new store on Pacific Coast**—This J. C. Penney Company store, recently opened at Medford, Ore., consists of main floor and mezzanine. Used in its construction, in combination with concrete floor slab and plaster ceilings, were 23 tons of Bethlehem Standard Joists and 27 tons of Bethlehem Longspan Joists. Floors built with Bethlehem Open-Web Joists keep fire from spreading for a period of two hours or more, depending upon the type of plaster used. In addition, they are economical, shrink-proof and sound-retardant, as well as immune to attack by vermin. For complete details about Bethlehem Joists, consult our catalog in Sweet's. *Architect:* J. C. Penney Company, Building Dept.; *Contractor:* Donald M. Drake Co., Portland, Ore.





...but this floor can take it!

IT'S *Koroseal*\*

THE WORLD'S FINEST FLOOR COVERING!



Yes, a million footsteps from now, this lovely Koroseal tile floor will be just as bright, just as lustrous, just as good as new!

Koroseal is the reason, of course! This miracle plastic is tough. It lasts 2 to 20 times longer than any other floor covering you've ever seen. It's grease and acid-resistant . . . is unaffected by soap or moisture . . . has no pores to clog with dirt or germs . . . and is easily cared for by an occasional thin wax coating!

It's colorful, too. Koroseal comes in 18 mirror-brilliant hues, and matchless Marbletone and Crystallone designs that blend perfectly in any interior. So write today for free samples and further information about this new wonder plastic building material! It's a Sloane-Blabon exclusive.

Also ask to see samples of Cove Base and Cove Molding in Koroseal. This new building material saves time and money. Installation is quicker than wood base-board or molding, it keeps new-looking years longer, and needs no painting.

\*© B. F. Goodrich Co.

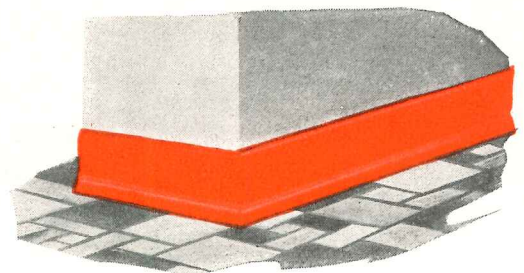

For information and sample write Dept. AR-3.

**SLOANE-BLABON CORPORATION**

295 FIFTH AVENUE • NEW YORK 16, N. Y.



# \$18,000,000 set of tools for the

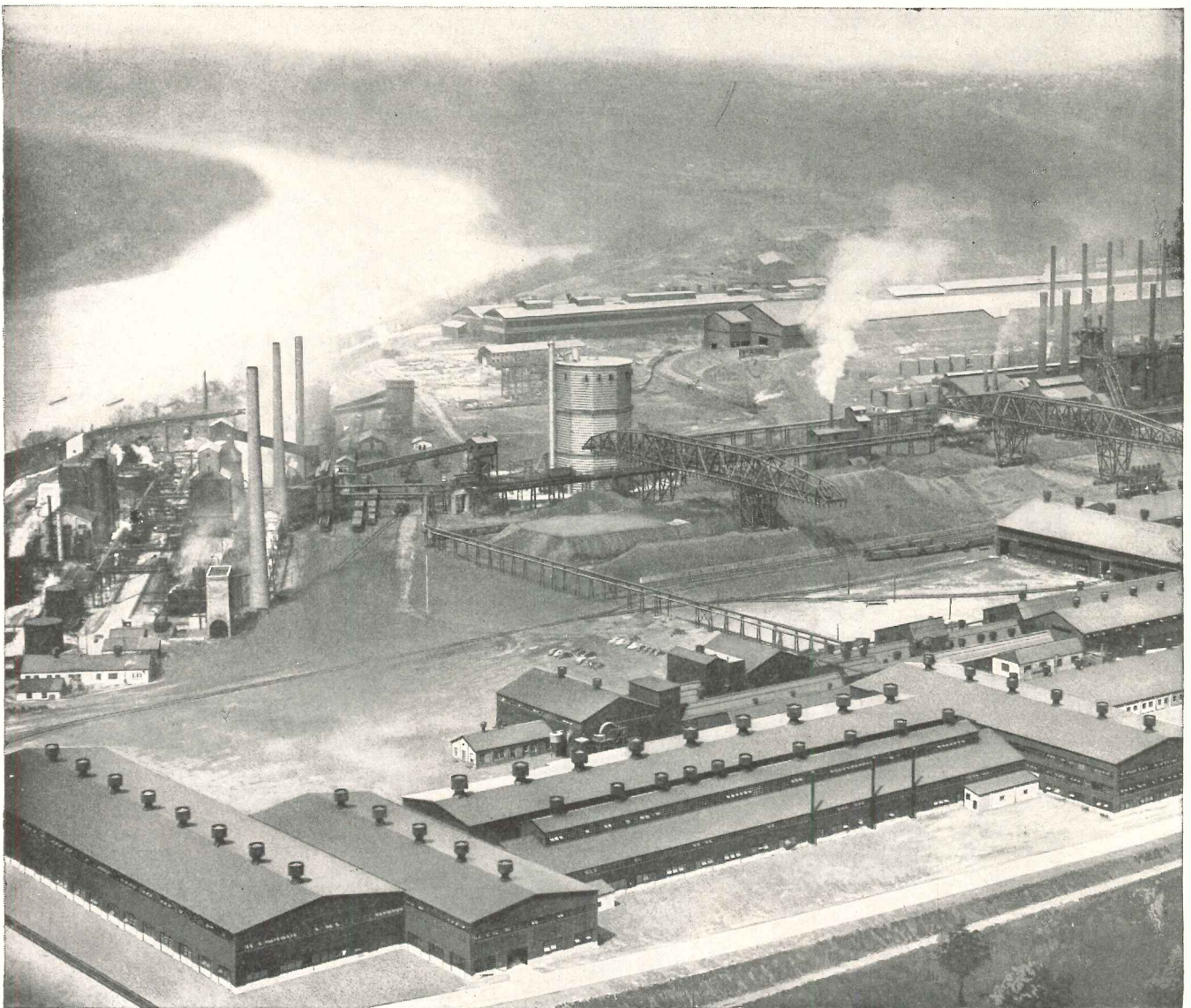

**CRUCIBLE**

first name in special purpose steels

hot and cold rolled

**STAINLESS SHEET AND STRIP**

# MASTER mechanic



When a *master* mechanic gets new tools, expect master workmanship. And when CRUCIBLE, *master* producer of tool, alloy and specialty steels, designs an \$18,000,000 mill specifically for hot and cold rolled stainless sheet and strip, you can rightly expect the best that modern facilities and generations of *specialty product* leadership can provide.

For here, at CRUCIBLE'S new Midland Mill, is an entirely new concept in stainless sheet and strip production . . . here, for the first time, stainless sheet and strip are made as *specialty products*, by specialty production methods, in a mill built from the ground up for this purpose. Here at Midland are no mills designed for carbon steel production, re-powered for the heavier duty of rolling stainless, but \$18,000,000 worth of *brand new* equipment, designed and built for *modern* hot and cold rolling of stainless steel — in widths from ½" to 50" inclusive, and in all gauges, grades and finishes.

This is important news to every designer and fabricator of stainless steel products. For CRUCIBLE, pioneer in stainless steel since its inception, now offers a *completely integrated* line—sheet, strip, plates, bars, tubing, wire, forgings and castings.

In short, you can turn with every confidence to the *first* name in special purpose steels for *every* form of stainless. One of the largest and most highly specialized technical forces in the steel industry is at your service for specific application advice. And there are comprehensive data sheets available for all grades. Your inquiry will be welcomed.

CRUCIBLE STEEL COMPANY OF AMERICA, Chrysler Building, 405 Lexington Ave., New York 17, N. Y.

Branches, Warehouses, and Distributors in Principal Cities. Consult your Telephone Directory or Thomas' Register for Nearest Office.

HIGH SPEED • TOOL • STAINLESS • ALLOY • MACHINERY • SPECIAL PURPOSE STEEL



Hallawell Seed Co. Store,  
San Francisco.  
Architect:  
Raphael S. Soriano,  
Los Angeles

for a *truly* good floor—

## NORTHERN HARD MAPLE

*truly* modern, *truly* economical, *truly* resilient

Surely, everyone concerned, from you and your client down to the carpenter-contractor's apprentice, will be glad to forget all about the "compromise" floors laid so numerous during the years of shortage.

You'll agree, it's mighty good news that good Northern Hard Maple Flooring is back now, in abundance!

It's available now for every job where your experience dictates its use . . . "First Grade" for the critical uses—"Second Grade" or "Second Grade or Better" on jobs where natural tone variations of the wood are acceptable—"Third Grade" where serviceability must be matched by maximum economy. *All*

**MFMA**-graded and trademarked—your assurance of strict standards of soundness.

Specify Northern Hard Maple, Birch or Beech, for every purpose that calls for the most enduring and desirable of wood floors—smooth, lifetime-lasting, bright and cheerful, easy to finish, to re-finish, to care for.

For catalog data on **MFMA** Northern Hard Maple, Birch and Beech Flooring, see Sweet's, Arch. 13/g/6—Eng., 4/5/22. Write for latest listing of all the many **MFMA**-approved floor finishing products and processes.

**MAPLE FLOORING MANUFACTURERS ASSOCIATION**  
Room 363 — 46 Washington Boulevard  
OSHKOSH, WISCONSIN

..... **FLOOR WITH** *NORTHERN* **HARD MAPLE** .....

*BEECH AND BIRCH*

# Park Avenue Building on the banks of the Mississippi

A few miles north of Davenport, Iowa, stands this newly erected, four-story, aluminum-clad office building.

"Why," we have been asked, "build a multiple-story building in the midst of unused acres?" "Why, use construction that matches the building requirements for congested areas, when the location doesn't demand it?"

Although serving as the administration building for Alcoa's newest rolling mill, this building was designed for Park Avenue, for Michigan Boulevard, for every other metropolitan area where factors of strength and fire resistance are necessary; where economics require permanence combined with low construction and upkeep costs.

Several types of materials and construction have been used in the same building. Here we hope to prove out our estimates on the feasibility of aluminum curtain wall

construction for commercial buildings. Already an analysis of costs has shown that large cast aluminum panels, backed by four inches of lightweight concrete, permit curtain wall construction at lower cost than with traditional materials of equal strength, fire resistance and permanence.

This is one of many Alcoa research projects now under way to provide practical tests of new uses for aluminum in architecture. As we find the answers, good or bad, we will tell you about them. Our engineers are always at your service to help you plan better, more economical buildings for the future. For information on any application of aluminum, call your nearby Alcoa Sales Office, or write ALUMINUM COMPANY OF AMERICA, 1867 Gulf Building, Pittsburgh 19, Pennsylvania.

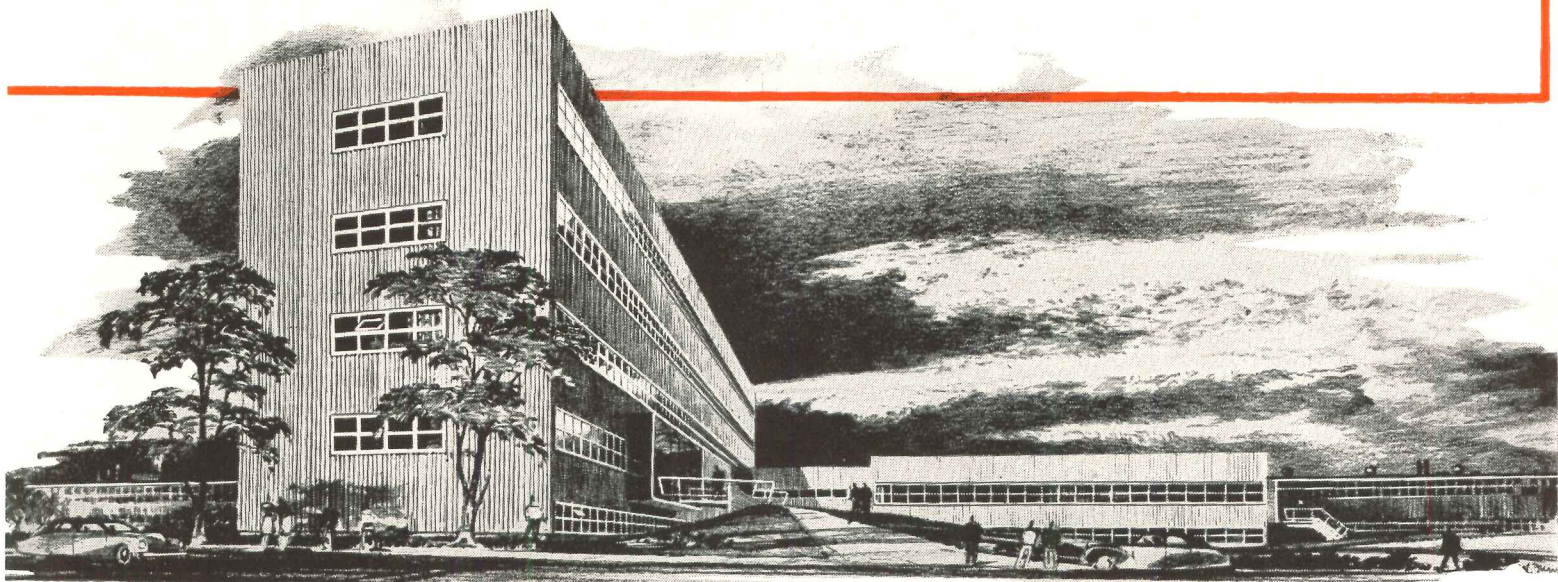

# ALCOA FIRST IN ALUMINUM

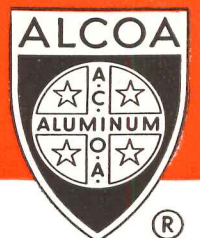

DT • SHEET & PLATE • SHAPES, ROLLED & EXTRUDED • WIRE • ROD • BAR • TUBING • PIPE • SAND, DIE & PERMANENT MOLD CASTINGS • FORGINGS • IMPACT EXTRUSIONS  
CENTRICAL CONDUCTORS • SCREW MACHINE PRODUCTS • FABRICATED PRODUCTS • FASTENERS • FOIL • ALUMINUM PIGMENTS • MAGNESIUM PRODUCTS

**ANY SIZE**

# Kitchen



The Crane Sunnycrest Sink, single basin, double drainboard

## ...IS A CRANE SIZE KITCHEN

Crane sets no limitations on size or style. There is a Crane sink for the modest kitchenette as for the elegant living-kitchen—a truly complete line.

No doubt that it's the *preferred* line . . . home owners have testified to this year after year.

That's true, of course, of Crane bathrooms, too—and here again you'll find a style for every taste, a price for every budget. In home heating, Crane supplies everything required for any system, any fuel.

See Crane Service for Architects for selections from the Crane line—and be sure to check plans early with your Crane Branch or Crane Wholesaler.

**THE ALL AMERICA**—America's finest counter-top sink, 38" x 21". Has all the features of Crane cabinet sinks—8" deep basins . . . retractable hose spray . . . 4" high shelf back . . . exclusive Crane Dial-ese controls.

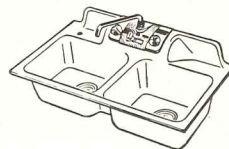

**THE KITCHEN QUEEN**—and fit for a queen! Double basin, double drainboard, all gleaming white porcelain enamel, 72" x 25 1/4". Retractable hose spray. Crane supplies automatic dishwasher, disposal unit if desired.



**THE HOMEMAKER**—just right for space-saving! Only 42" x 25 1/4", it boasts a deep, full basin and plenty of cabinet space below. Also from Crane: wall and base cabinets to complement the sink.

# CRANE

CRANE CO., GENERAL OFFICES:  
836 S. MICHIGAN AVE., CHICAGO 5  
PLUMBING AND HEATING  
VALVES • FITTINGS • PIPE

NATION-WIDE SERVICE THROUGH BRANCHES, WHOLESALERS, PLUMBING AND HEATING CONTRACTORS



## SOUND CONDITIONING

### WHICH MATERIAL WOULD YOU SELECT?

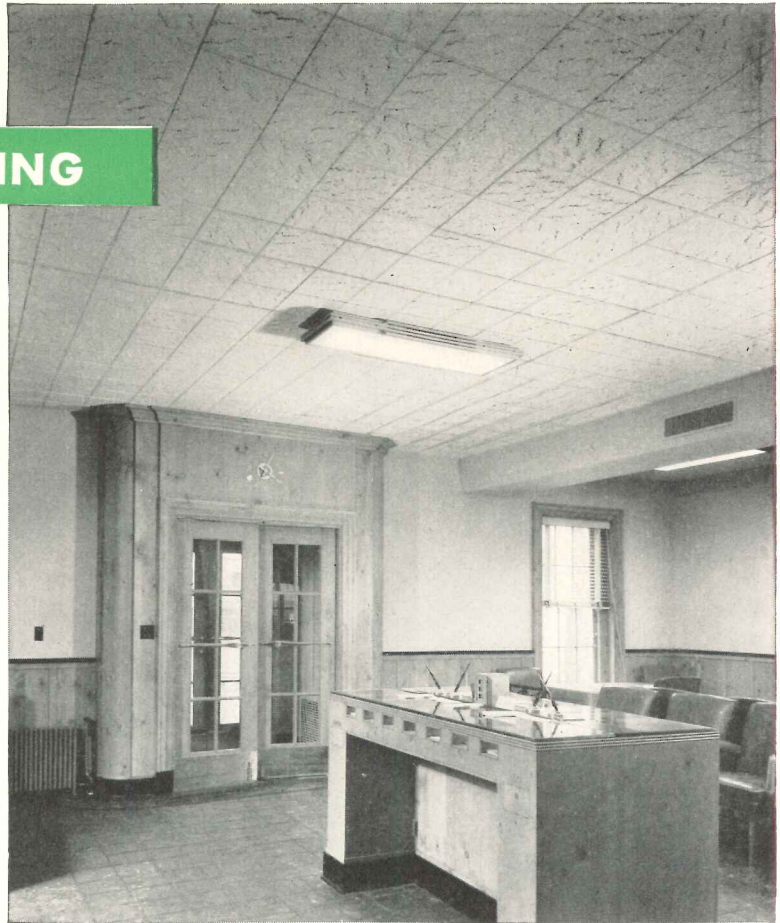

ARCHITECT: WILLIAM E. HUBER

Lumber yard office, built in 1904, is being remodeled into a branch bank. Client wants modern acoustical efficiency. Material to be specified must fit period styling of bank's interior. Age of building frame makes fire-resistance a specially important requirement.

#### **Here's what the architect decided:**

Several products would meet most of the requirements. A metal pan ceiling, such as Armstrong's Arrestone, would provide very high efficiency noise control and incombustibility. Armstrong's Cushiontone could be provided with a fire-resistant paint finish and would offer a high degree of efficiency. But the ceiling ideally suited to the job was Armstrong's Travertone because of the unusual beauty of its white, fissured surface. Made of mineral wool, it is incombustible. And it stops up to 70% of the noise that strikes its surface.

\* TRADE-MARK REGISTRATION APPLIED FOR.

Other advantages offered by Travertone were its heat insulating value, its 79% light reflection factor, its easy maintenance, and its moderate cost installed. Light in weight, it could be applied directly to the existing ceiling plaster, by means of an adhesive.

Whether the most important requirement in your plans is beauty, low cost, incombustibility, moisture-resistance, or maximum efficiency, there's an Armstrong's acoustical material that meets it fully. For complete details, see Sweet's file, Section 11a, or write direct to Armstrong Cork Company, 2406 Stevens Street, Lancaster, Pa.

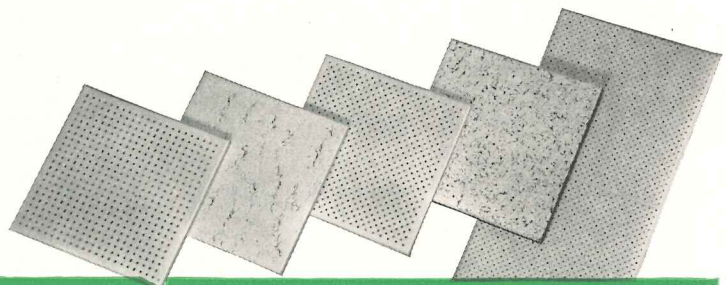

## ARMSTRONG'S ACOUSTICAL MATERIALS

low-cost  
CUSHIONTONE®

beautiful  
TRAVERTONE\*

incombustible  
CUSHIONTONE F

moisture-resistant  
CORKOUSTIC®

efficient  
ARRESTONE®

# 1818 HOPE'S 1949

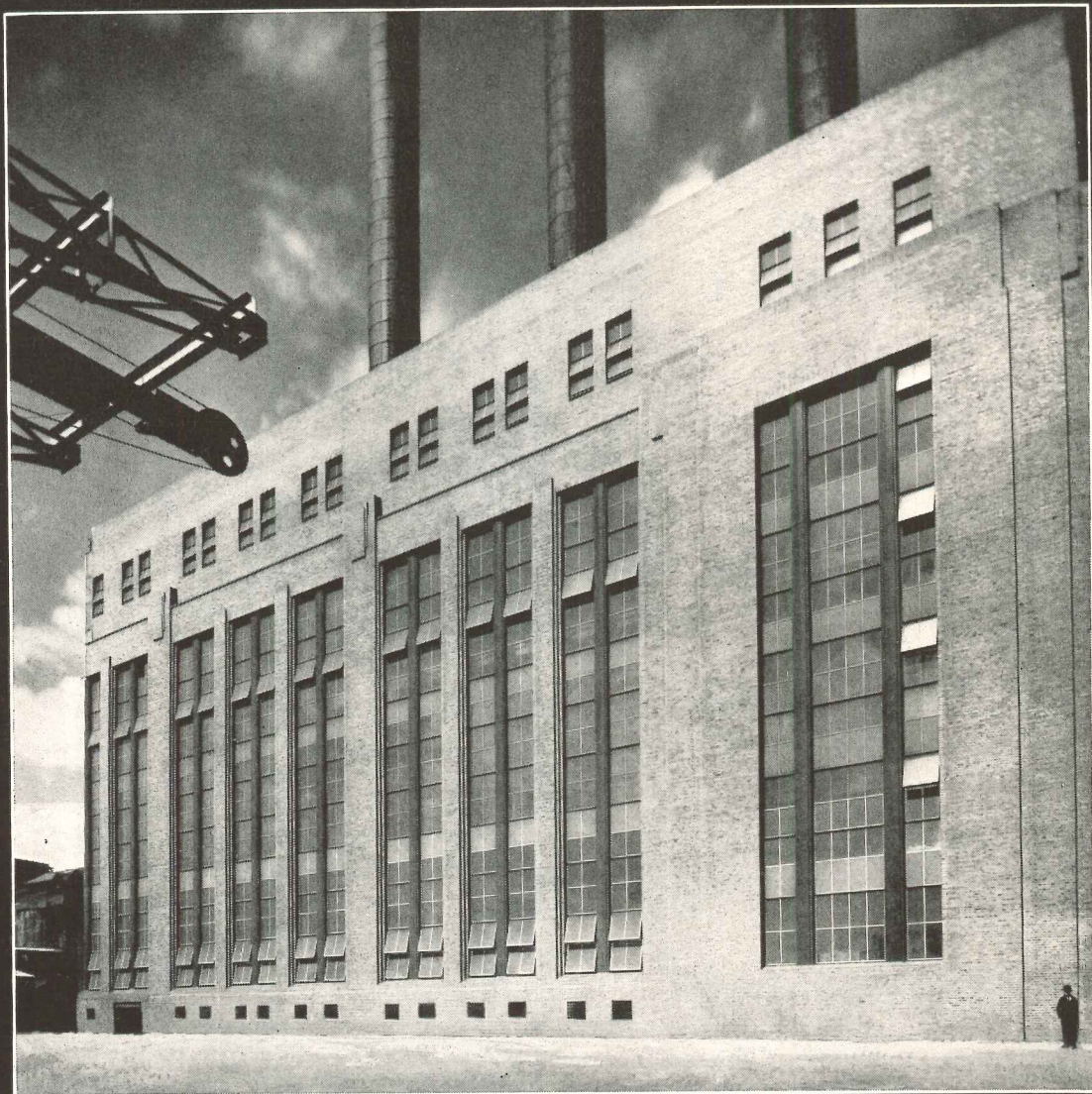

THE HOPE'S *LOK'D BAR* FACTORY SASH recently installed in this Power Station building are made to special size and layout. Their height, 63', 0", is indicated by the size of the figure in the lower right foreground. The mullions are 10 gauge pressed steel reinforced by structural members. Hope's *LOK'D BAR* Catalog describes, with full-scale drawings, the exclusive principle of their design, and Hope's Engineering Department will be glad to submit details for similar installations on request.

**HOPE'S WINDOWS, INC., *Jamestown, N. Y.***

THE FINEST BUILDINGS THROUGHOUT THE WORLD ARE FITTED WITH HOPE'S WINDOWS

# G-45-30-2-P

*What does this*  
**FLEUR-O-LIER**  
**INDEX SYSTEM**  
**NUMBER**  
**MEAN?**

In a specification, it denotes the exact kind of lighting performance desired. "G" stands for General Diffuse lighting distribution; "45" for 45° side shielding; "30" for 30° end shielding; "2" for a brightness in shielded zone of not more than 2½ footcandles per square inch; "P" means Pendent mounting.

For a fixture, those symbols mean that Electrical Testing Laboratories, Inc., after photometric tests, find it has those performance characteristics.

Thus, it is now possible for the specifier to express simply and precisely the lighting performance he wants. And the buyer can now buy fixtures and know in advance how they will perform when installed. For, in addition to the Index System rating, complete photometric data, together with coefficients of utilization are supplied for each Fleur-O-Lier fixture,

And the Fleur-O-Lier label certifies that the fixture is "right" mechanically and electrically.

**Fleur-O-Lier Gives Complete Information —**

All the data needed to make an intelligent choice of fixtures is provided by Fleur-O-Lier. You get—

1. An Index System Rating
2. Photometric test data
3. Coefficients of Utilization
4. Certification

You're *sure* when you insist on Fleur-O-Lier.

**FLEUR·O·LIER**  
*Manufacturers*

2116 Keith Building • Cleveland 15, Ohio

Fleur-O-Lier is not the name of an individual manufacturer, but of a group of fixtures made by leading manufacturers. Participation in the Fleur-O-Lier program is open to any manufacturer who complies with Fleur-O-Lier requirements.

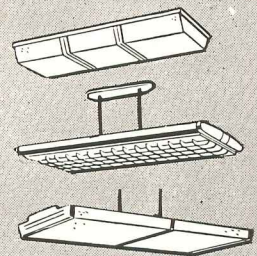

# Designed for modern structures

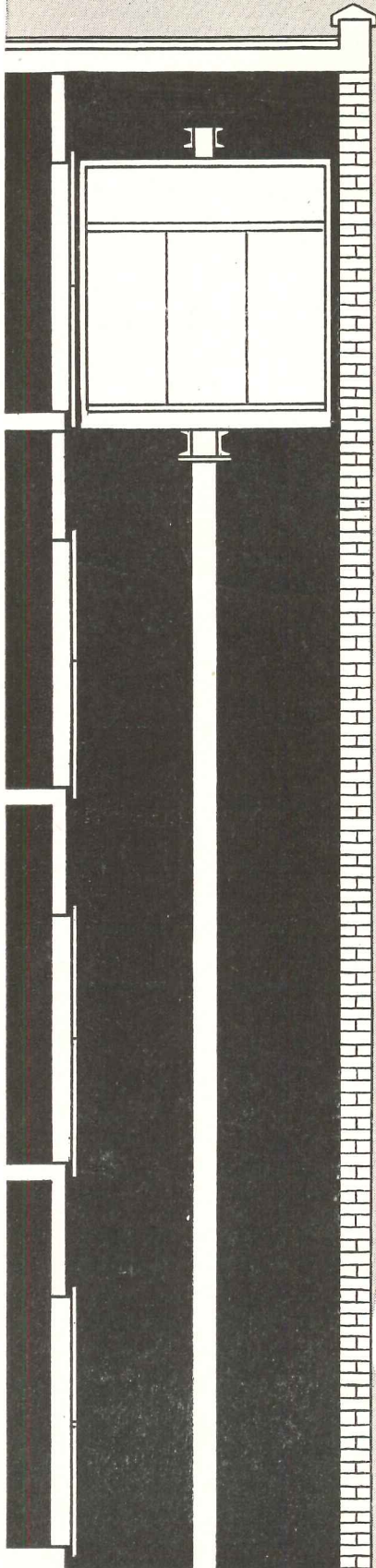

## ROTARY'S OILDRAULIC ELEVATOR SIMPLIFIES BUILDING DESIGN, SAVES SPACE, CUTS COSTS

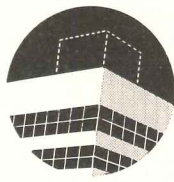

### No costly, unsightly penthouse

Because it's pushed up from below, not pulled from above, the Oildraulic Elevator requires no unsightly penthouse. This permits a saving of several hundred to thousands of dollars, and improves the design of the building.

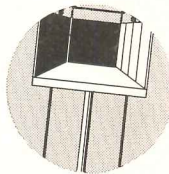

### Lighter shaftway structure

There's no need for heavy, load-bearing side-wall supporting columns and footings to carry the car, counterweight, overhead machine, and the load. Rotary's Oildraulic jack supports the entire system from below.



### No special machine room

A machine room can usually be dispensed with because Rotary's compact power unit can be located at any convenient spot on any landing and on any side of the hatchway . . . under a stairway, in a closet or basement.

### Why You Can Confidently Recommend Oildraulic Elevators to Your Clients

- 1 Smooth starts and stops are assured by the automatic unloading valve in Rotary's famous Oildraulic Controller.
- 2 Automatic floor leveling gives  $\frac{1}{4}$ " landing accuracy. This is particularly important with power truck loading.
- 3 Powerful Oildraulic jack, precision power unit, and Oildraulic Controller guarantee economical operation.
- 4 The Oildraulic is engineered and built by Rotary, oldest and largest maker of oil hydraulic elevators.
- 5 Rotary's coast-to-coast field organization offers the most complete service in the oil hydraulic elevator field.
- 6 Thousands of leading companies can recommend Oildraulic Elevators based on actual experience.

Write for A.I.A. File 33  
Rotary Lift Co., 1006 Kentucky, Memphis

**Rotary**<sup>®</sup>

**Oildraulic Elevators**  
For 2, 3 or 4-Story Service

# INSULATED STEEL WALLS

and STEEL DECK ROOFS  
for INDUSTRIAL and COMMERCIAL BUILDINGS

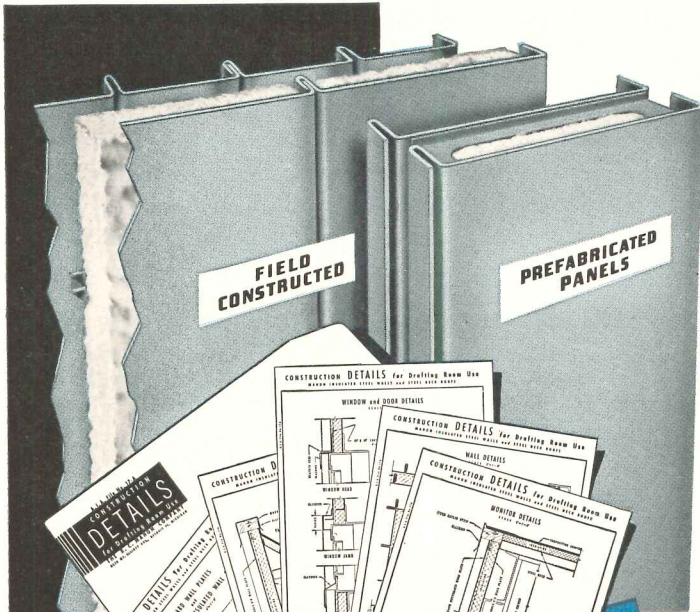

Mahon Insulated Steel Walls are ideally suited for industrial and commercial buildings, and for many special purpose structures, such as power houses and transformer stations, where high expanses of wall are encountered. Walls up to sixty feet in height may be constructed without horizontal joints . . . this feature alone has found favor with many architects throughout the country. Vertical ribs are six inches on centers on the outside of the wall with interlocking ribs one foot on centers. The inside surface of the wall is smooth, with vertical interlocking joints one foot on centers. This type of wall construction in combination with a Mahon Steel Deck Roof costs less, provides a firesafe, permanent building which can be quickly and economically erected. See Sweet's File for complete information.

**THE R. C. MAHON COMPANY**

Detroit 11, Michigan • Chicago 4, Illinois

Representatives in all Principal Cities

Manufacturers of Insulated Steel Walls, Steel Deck for Roofs, Ceilings, Floors and Partitions. Rolling Steel Doors, Grilles, and Underwriters' Labeled Rolling Steel Doors and Fire Shutters.

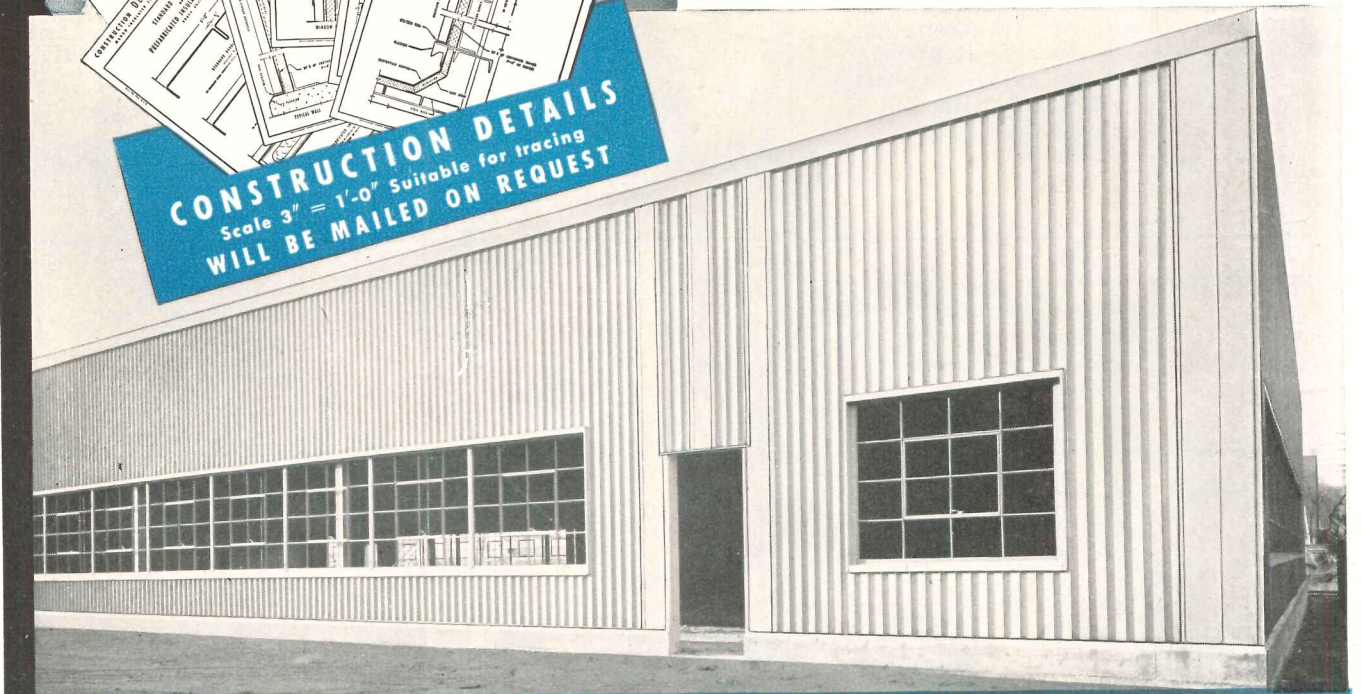

A typical building constructed with Mahon Insulated Steel Walls throughout, and Mahon Steel Deck Roof. Note pillaster effect obtainable in walls.

# MAHON

# fits every budget -

**Gold Bond's  
COMPLETE LINE  
OF ACOUSTICAL  
PRODUCTS**

**meets every sound conditioning need!**

**N**O matter what you're planning, if you have an acoustical problem Gold Bond can solve it. If your big problem is budget, Gold Bond's complete line of acoustical products can solve that one too.

Take a look at the chart below. Notice that the complete line of Gold Bond acoustical products covers a noise reduction coefficient range from .55 to .85. A range wide enough to cover the requirements of any building: hospital, school, office building or auditorium. The price on Gold Bond Acoustical Products is right, too, to help you meet your budget. Factory-appointed Gold Bond Acoustical Applicators insure good work. If none is listed in your phone directory under "Acoustical Contractors" please write to us.

**NATIONAL GYPSUM COMPANY, BUFFALO 2, NEW YORK**

*Over 150 Gold Bond Products including gypsum lath, plaster, lime, wall-boards, gypsum sheathing, rock wool insulation, metal lath products and partition systems, wall paint and acoustical materials.*

Product	Special Characteristics	Noise Reduction Coeff.	Thickness	Sizes	Finish
<b>ACOUSTIMETAL</b>	Low maintenance cost. Can be washed or painted any number of times. Panels quickly removed for access to plumbing and wiring. Fireproof, permanent, salvageable.	.85	1 1/4"	12" x 24"	Alkyd resin enamel finish, electrostatically applied for uniform density and coverage. Dried by infra-red light. Bonderizing of metal assures greater adhesion of paint.
<b>ACOUSTIFIBRE</b>	Perforated wood fibre tile. Round, clean holes drilled deep into porous core. Chemically-treated against mould and fungus. Sanitary, cleanable, repaintable.	.55 .65 .70	1/2" 5/8" 3/4"	12" x 12" 12" x 24"	Factory-applied shell-white finish results in high light-reflection.
<b>ECONACOUSTIC</b>	Low cost wood fibre tile. Distinctive brushed texture surface offers unusual natural beauty. Cleanable with vacuum cleaner.	.60 .70	1/2" 1"	6" x 12" 12" x 12" 12" x 24" 16" x 16"	Prepainted white. May be spray-painted when other colors are desired.
<b>TRAVACOUSTIC</b>	Fireproof mineral tile. Closely resembles beautiful travertine stone. Fissures vary in size, depth, and arrangement. Permanent, sanitary, acoustically efficient.	.65 .70	5/8" 3/4"	6" x 12" 12" x 12" 12" x 24"	Non-glaring white finish applied at the factory gives high light-reflection. Repaintable with brush or spray gun.



## UNIT HEATING...

### *its uses and advantages*

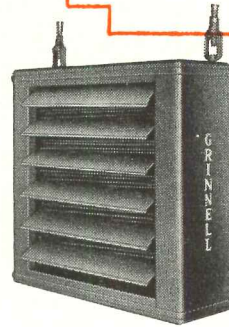

**Where it is used** Unit heating is widely used in industrial plants and warehouses, garages, stores and public buildings where the following advantages are important.

**Low first cost** Unit heaters are so efficient and so compact that their heating capacity is often equivalent to the capacity of cast iron radiation or pipe coils of twice the cost. Additional savings are effected because the system requires a proportionately smaller amount of pipe, fittings and accessories.

**Economy of operation** Heat is forced down to the working level... not banked uselessly at the ceiling level. Heat is turned on and off merely by throwing a switch either manually or automatically by simple thermostatic controls. The rapid response means that heat is furnished only when and where it is wanted... no heat is wasted.

**Heating comfort** Unit heaters provide quick heating from a cold start. Desired temperatures are easily maintained within a close range. Heat is uniformly distributed in the working zone by forced air circulation. It

is a very flexible system because different or changing heating requirements are easily satisfied by means of different models, a range of capacities, single- or two-speed motors and individual thermostatic controls.

**Adaptability to equipment and floor layout** The units and the simple piping are overhead where they do not interfere with arrangement of operating machinery or equipment and do not take up valuable floor or wall space. Units are easily relocated at any time to meet changes in plant layout or heating requirements.

**Thermolier unit heaters have important construction advantages** The design of Thermolier unit heaters is the product of Grinnell Company's ninety-nine years of heating experience. Both architects and contractors like Thermolier's durability, freedom from maintenance troubles and dependable operation. Typical of its construction features is the patented internal cooling leg which permits the use of a plain thermostatic trap, the simplest, least expensive kind of trap. For full details on Thermolier features, capacities and types, see your Sweet's Files.

# THERMOLIER

## *Unit Heaters*

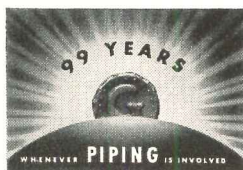

## GRINNELL

Grinnell Company, Inc., Providence, Rhode Island. Branches: Atlanta • Buffalo • Charlotte • Chicago • Cleveland • Cranston • Fresno • Kansas City • Houston  
Long Beach • Los Angeles • Milwaukee • Minneapolis • New York • Oakland • Philadelphia • Sacramento • St. Louis • St. Paul • San Francisco • Seattle • Spokane

# FISSURETONE!

... the beautifully fissured  
**MINERAL FIBRE  
ACOUSTICAL TILE**

Created and  
produced by the world's largest  
manufacturer of  
Sound Conditioning products!

**Fissuretone** brings architects, designers and decorators an entirely new and "different" acoustical medium... beautifully suited for use in any public or private, commercial or domestic building.

**New dignity and style** are now available in this highly sound-absorbent mineral fibre tile. **FISSURETONE's** handsomely fissured surface rivals the finest travertine and is factory-finished in soft, flat white of a high light-reflection rating.

**Both lightweight and rigid**, **FISSURETONE** is incombustible, too, and has the paintability inherent to products of its type.

**Now you can design** quiet dignity into any room! Both functional and decorative, **FISSURETONE** proves again why Celotex is the recognized producer of the most widely accepted line of Sound Conditioning products.

## **ACOUSTI-CELOTEX**

*Sound Conditioning*

PRODUCTS FOR  
EVERY SOUND CONDITIONING PROBLEM

Sales Distributors Throughout the World  
In Canada: Dominion Sound Equipments, Ltd.

**THE CELOTEX CORPORATION**

120 South La Salle Street  
Chicago 3, Illinois

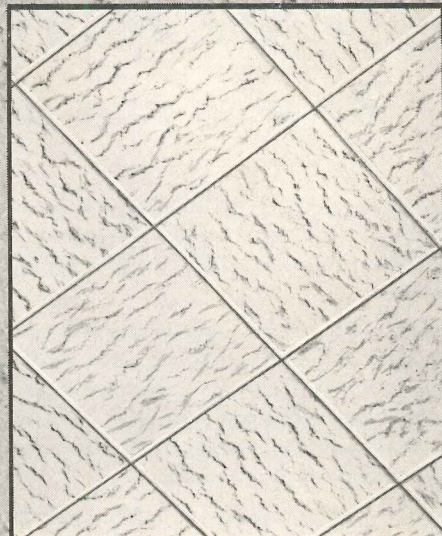

FISSURETONE'S new and "different" random-fissured surface gives a beautiful new pattern and style to Sound Conditioned ceilings.



# NOW! Richmond offers you 4 China Ledgeback Lavatories!

22" x 19"

20" x 18"

**The Richmond BROMLEY**—NOW available in two sizes: 22" x 19" and 20" x 18". Richness and style are yours with the beautiful Bromley. This shelfback, square bowl lavatory features a front overflow, anti-splash rim, and recessed soap dishes. The handsome, modern design of the Bromley makes this lavatory at home in mansion or cottage—apartment or powder room. To be sure of customer satisfaction—specify or install the beautiful Bromley. Plate #G-132.

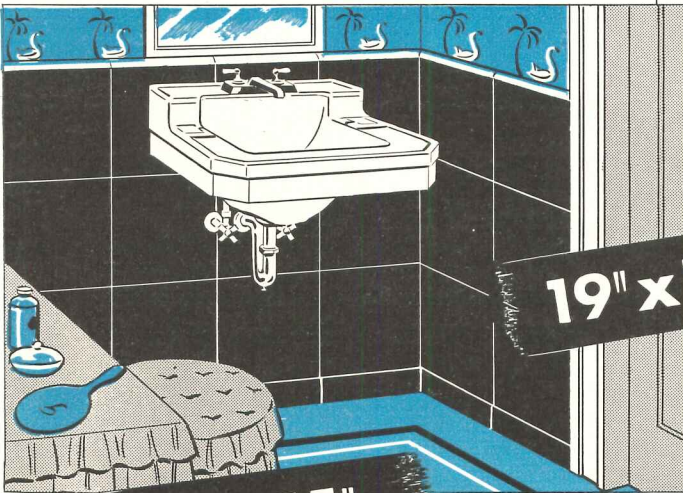

19" x 17"

**The New Richmond RICLEDGE**—NOW available in two sizes: 19" x 17" and 18" x 15". A compact lavatory for your space-saving jobs. Small in size and price, this top quality unit is long on big lavatory features: raised shelfback, recessed soap dishes, anti-splash rim, integral front overflow and Richmond high-gloss finish. This wall hung lavatory, punched for center set fittings, is ideal for the modern home where space is a problem. Plate #G-152.

18" x 15"

## For Ledgeback Lavatories at their very best—Specify or Install Richmond Vitreous China

Ledgeback lavatories for any location—for any type of installation—are in the Richmond line of fine vitreous china. Bathrooms or powder rooms—if it's ledgeback lavatories you want—Richmond has the best you can get—and in the size you want. Check these sizes against your current jobs.

Richmond's complete line has all other types, too—enameled cast iron or vitreous china—slab or highback—wall hung or pedestal. When you recommend or install a Richmond, you are picking the best. The best in design—in beautiful, lasting finish—and in customer acceptance.

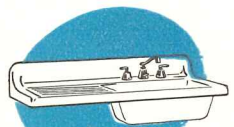

Richmond's whiter-white enameled cast iron sinks are at home in any kitchen.

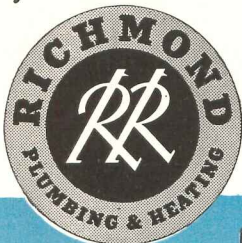

# RICHMOND

RICHMOND RADIATOR CO.—AFFILIATE OF REYNOLDS METALS CO.



Vitreous China

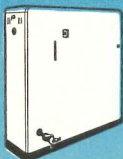

Gas Boilers

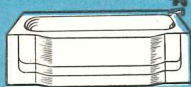

Enameled Cast Iron Ware

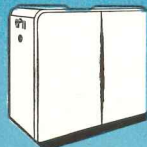

Winter Air Conditioners  
Gas—Cast iron or steel  
Oil—Steel

See your wholesaler or mail coupon today:

AR-6

Richmond Radiator Company  
19 East 47th Street  
New York 17, New York

Please send me further information and details on the new additions to the Richmond line of fine Vitreous china lavatories. No obligations, of course.

Name.....

Company.....

Address.....

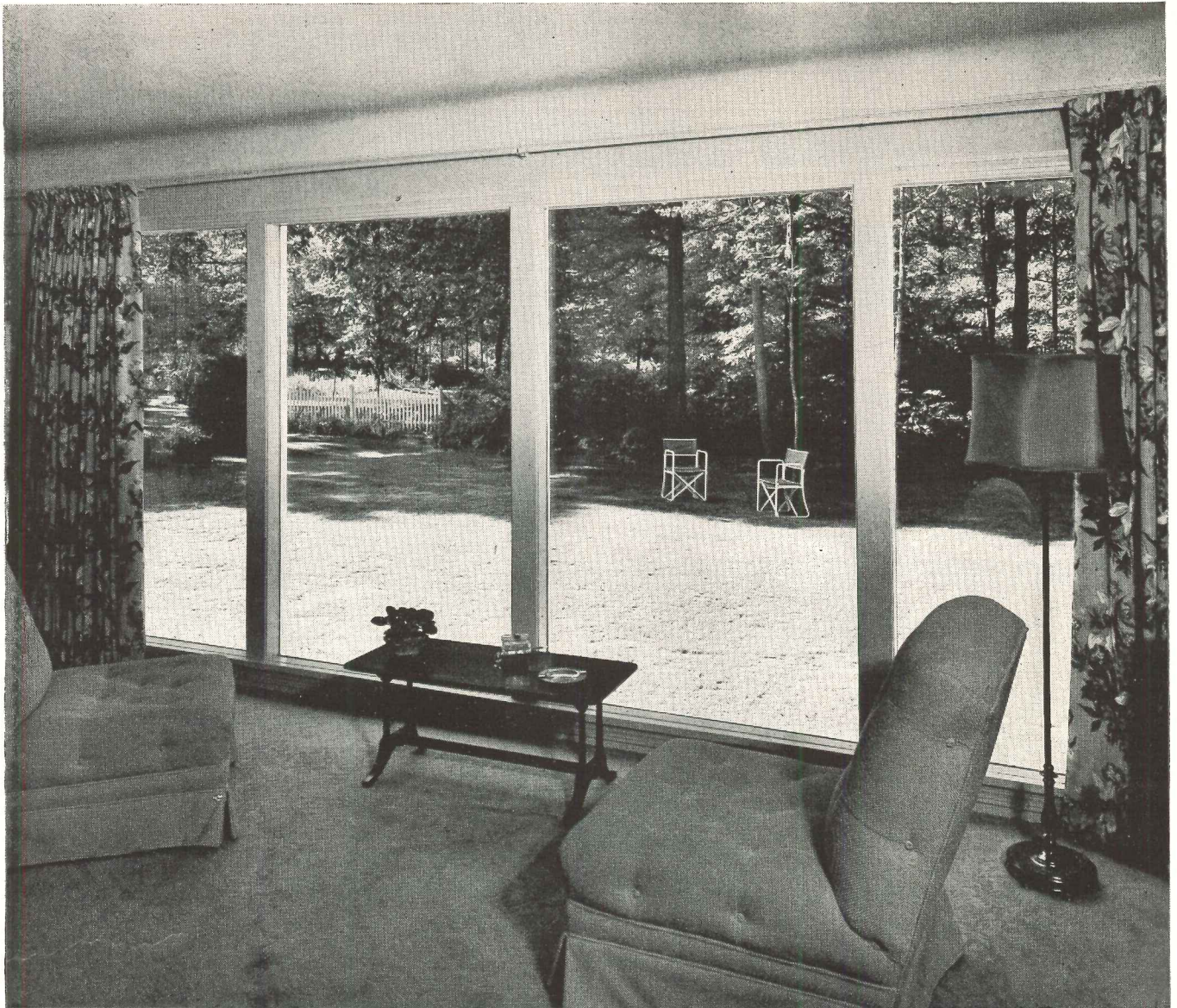

Architect: Melvin Warner, Berea, Ohio

## *More Daylight Inside* plus year-round comfort

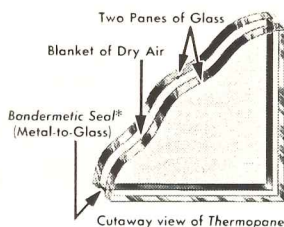

For better vision specify *Thermopane* made with polished plate glass. For details, write for our *Thermopane* book and standard size list.

You can assure clients the comfort they want with open design by specifying *Thermopane*\*.

*Thermopane* is the sealed, double-glass insulating window-pane that stays in all year . . . takes storm sash off maintenance budgets. In summer, *Thermopane* helps keep rooms cooler. In winter, it cuts heat loss through glass, reduces downdrafts, minimizes condensation, saves fuel. *Thermopane*'s high insulating efficiency gives you more freedom to open homes to outdoor beauty . . . with walls of glass.

\*®



# *Thermopane*

MADE ONLY BY LIBBEY-OWENS-FORD GLASS COMPANY

669 Nicholas Building, Toledo 3, Ohio.

**TO MAKE  
ENDS MEET**

*Electrically*

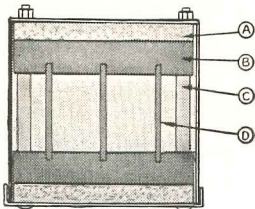
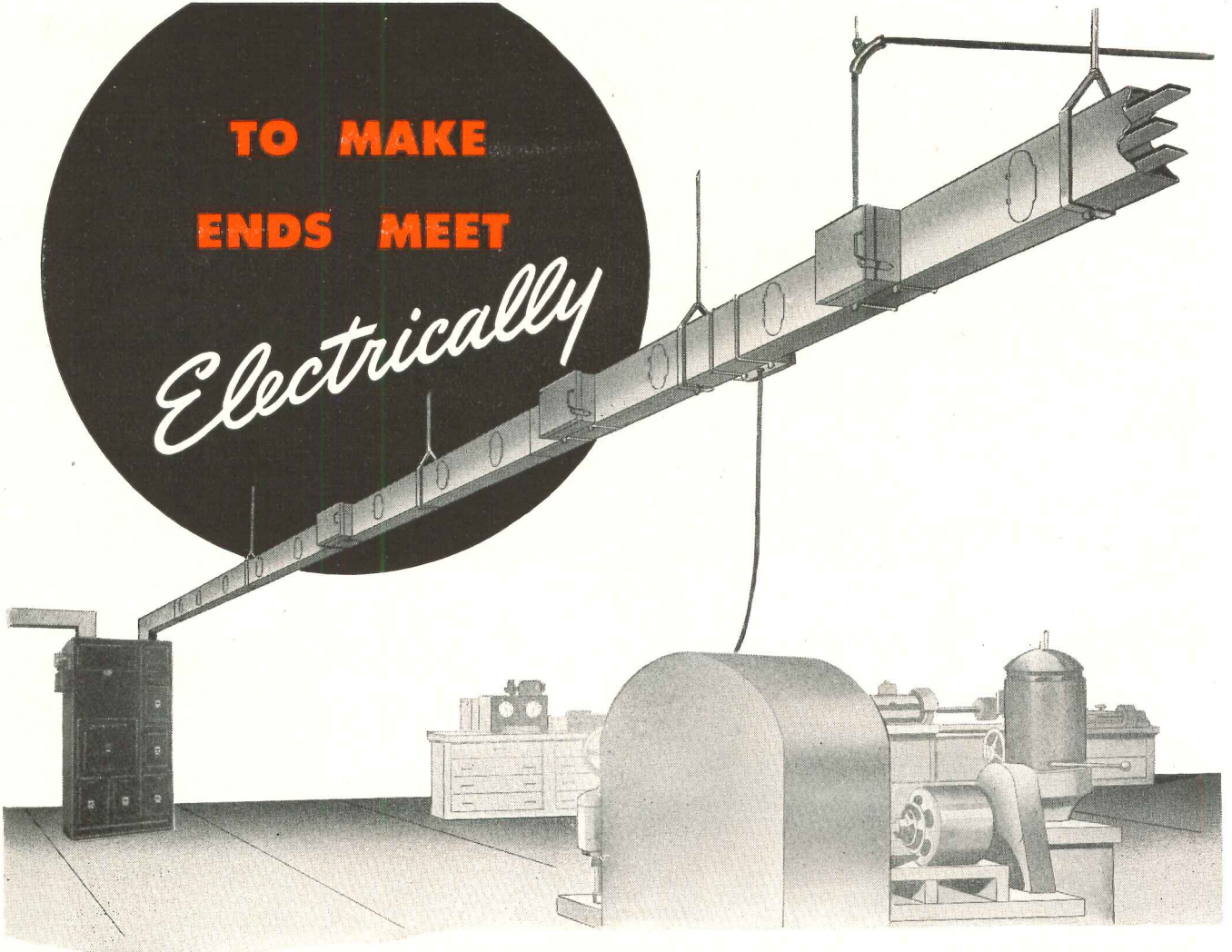

(A) Steel supporting channel; (B) Rugged porcelain insulators; (C) Fibre insulator spacers; (D) Copper bus bar conductors.

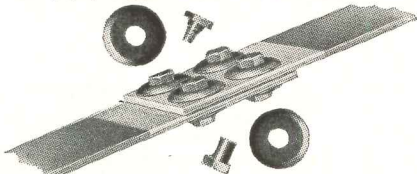

**PLUGIN <sup>FA</sup> BUS BAR JOINT.** All bus bars are hard drawn, round edge, rectangular copper of 98% conductivity. Joint contact surfaces are heavily ELECTRO-SILVER Plated. Brass jam bolts, with compression washers on each side, fit into elongated holes to permit contraction or expansion at each joint.

**F**rom power source to machine, the most economical electrical path is Plugin <sup>FA</sup> Busduct! It saves time! It saves money! It saves electricity!

Plugin <sup>FA</sup> Busduct provides a plugin outlet every foot of the way . . . permitting relocation and installation of machinery quickly. Mounted on ceilings, along walls, or even above baseboards, standard 10-foot lengths and special lengths can be arranged to fit any electrical requirement. Plugin <sup>FA</sup> Busduct eliminates costly temporary connections and expensive, long lead-ins . . . permits a speedy change in plant or electrical layout without disrupting production . . . and reduces voltage loss to a minimum.

Any way you look at it, Plugin <sup>FA</sup> Busduct makes ends meet . . . electrically, efficiently, and economically!

**Capacities: 225 to 1000 amps., 600 volts, 2-3-4 conductors.**

Write for Bulletin No. 701 or see your nearest <sup>FA</sup> Representative (he's listed in Sweet's).



*Frank Adam Electric Co.*

ST. LOUIS 13, MISSOURI

Makers of BUSDUCT • PANELBOARDS • SWITCHBOARDS • SERVICE EQUIPMENT • SAFETY SWITCHES • LOAD CENTERS • QUIKHETER



Only Frigidaire  
Kitchen Cabinets  
Have Amazing

## Vitalast Worktops

No other cabinet top material offers so many advantages! It's tough, molded composition—permanently bonded to the steel cabinet top under tremendous pressure and heat. Easy to clean, waxes beautifully—yet is not slippery.

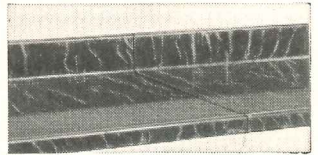

**Smooth, one-piece work surface** results when two or more base cabinets are joined.



**Fireproof, scorch-proof!**  
Can't be damaged even by hot utensils direct from range.

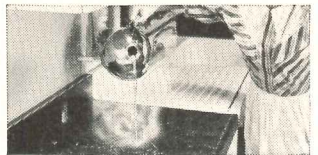

**Water proof, acid proof!**  
Completely unaffected by boiling water, vinegar, fruit juices.



**Stain-proof—grease-proof!**  
Even hot grease from the skillet can't stain or mar Vitalast!



**Resilient!** Won't chip dishes—yet it can't be scratched or marred in normal kitchen use.

# New Frigidaire Kitchen Cabinets

give custom-built results at standard cabinet prices!

The new Frigidaire Kitchen Cabinet units are so flexible in arrangement, permit so many different combinations that they make any kitchen look custom-built—without expensive building alterations or special designing. Moreover, they combine with Frigidaire Refrigerators, Electric Ranges and Cabinet Sinks to form efficient, time-and-energy-saving work centers.

**Adjoining cabinets provide unbroken work surfaces.** Any two or more Frigidaire base cabinets can be locked together so snugly that the joints in the Vitalast worktops can barely be seen. No moldings or fillers are needed. And, as shown at right, Vitalast offers advantages that can't be matched by any other cabinet top.

**These beautiful new cabinets** include eight wall cabinet sizes, six base cabinet sizes

and a utility cabinet. All have Dulux-finished, all-steel bodies that can't warp, swell or shrink—that *keep* drawers and doors working smoothly.

**New Frigidaire Cabinet Sinks!** The 54-inch model has two drainboards. The 48-inch size provides two bowls and a space-saving, sliding drainboard. Both have stainless porcelain sink tops and Dulux-protected all-steel bodies—new silent drawer guides—durable, completely concealed hinges. Both sinks offer finger-tip sprays, built-in cutting boards, rust-proof chromium soap trays and crumb cups—in addition to a really large amount of *organized* storage space. For full facts see your Frigidaire dealer. Find his name in Classified Phone Directory. Or write Frigidaire Division of General Motors, Dayton 1, Ohio. In Canada, Leaside 12, Ontario.

## FRIGIDAIRE Makes a Good Building Better



Refrigerators • Electric Ranges • Electric Water Heaters • Automatic Washer • Electric Ironer  
Automatic Electric Dryer • Home Freezers • Kitchen Cabinets  
Cabinet Sinks • Electric Dehumidifier • Air Conditioners • Water Coolers • Commercial Refrigeration

# Get it on paper **FIRST!**

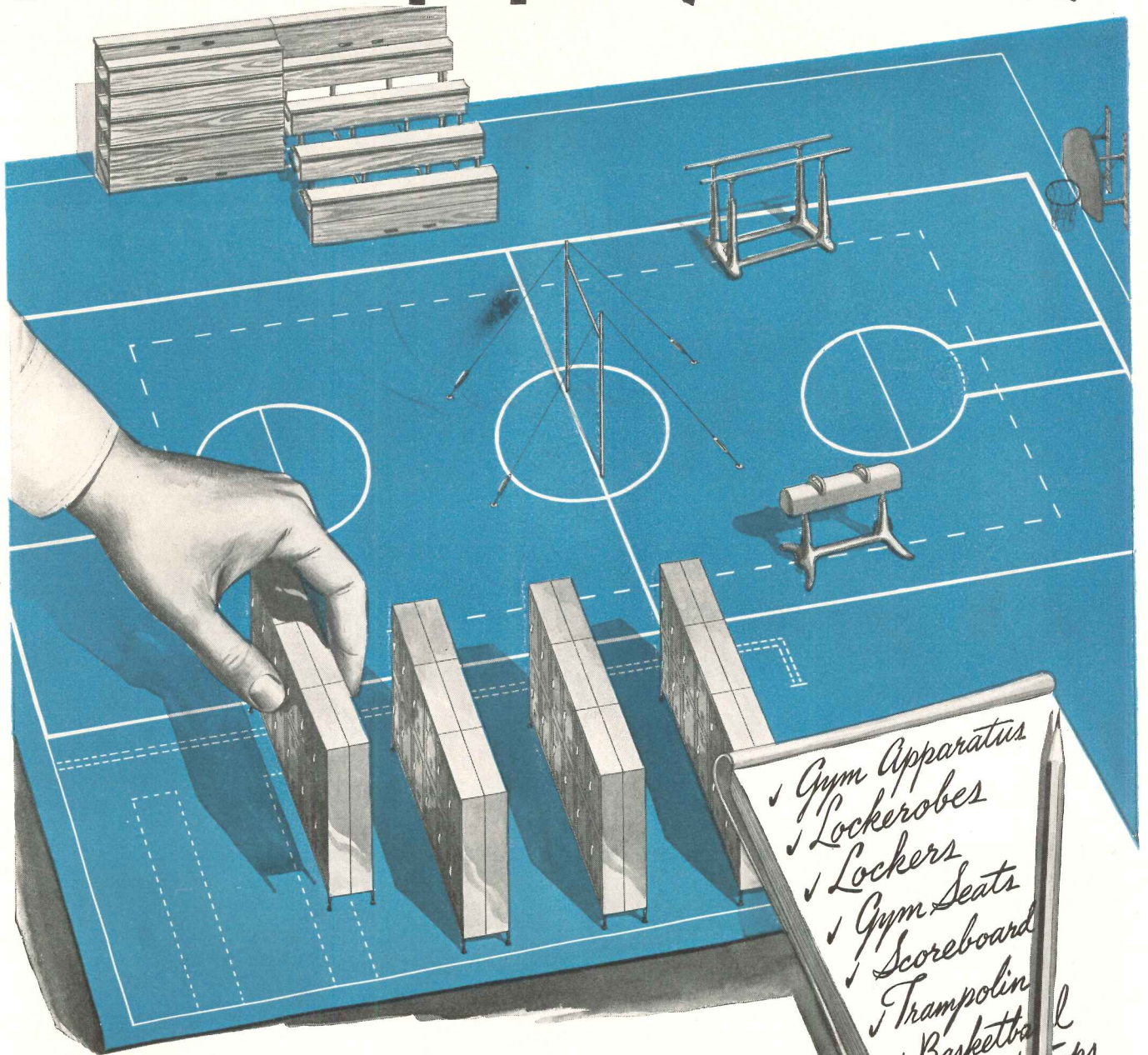

## rely on Medart for complete planning service . . .

Whatever type installation you are considering, consult Medart engineers first . . . for honest, unbiased analysis of your installation problems. The use of Medart planning and engineering facilities entails no cost or obligation on your part. Yet the savings . . . in actual installation costs . . . and in arriving at the proper kind of

installation based on your architectural requirements . . . are apt to be considerable! Yes . . . it costs no more . . . and results are sure, if you put it on paper, *first!* And remember! Over 75 years of serving the nation's schools has given Medart unquestioned leadership in the field of locker room, gym and physical educational equipment.

**fim**

**FRED MEDART PRODUCTS, INC.**

3535 DEKALB STREET

ST. LOUIS 18, MISSOURI

LEADERS FOR OVER 75 YEARS IN THE MANUFACTURE OF SCHOOL EQUIPMENT

Briggs  
presents

A NEW  
**BRIGGS**  
VITREOUS  
*At New*

**NEW, NEW, NEW!** A complete line of *vitreous china* lavatories by Briggs to add to the already outstanding line of Briggs Beautyware plumbing fixtures and brass fittings!

**SMART, SMART, SMART!** A wide variety of fixtures and fittings to harmonize with any decorative scheme for new homes or modernization work! **DIFFERENT, DIFFERENT, DIFFERENT!**

Yes . . . full of design features you'll find in no other lavatories! **COLOR,**

**COLOR, COLOR!** Sandstone . . . sky blue . . . sea green . . . ivory. **FOUR** exciting colors, plus white, moderately priced to fit every building budget.

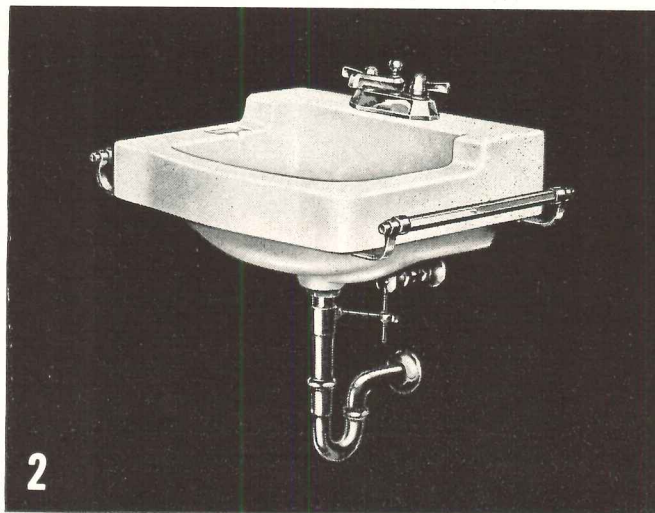
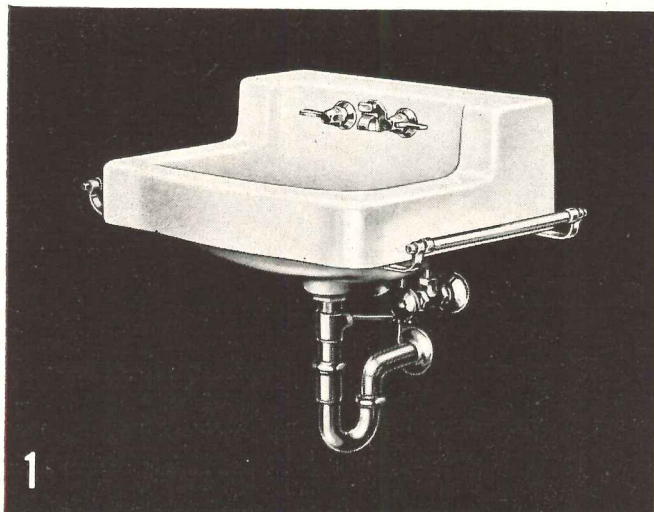

**The new Briggs Beautyware lavatories are:**

- 1 **THE WHITTIER** (B-3210 HT), 19" x 17", shelf back, wall pattern, with chromium towel bars. Also available with chromium plated legs.
- 2 **THE WHITMAN** (B-3310 HT), 20" x 18", ledge back, wall pattern, with chromium towel bars and soap depression. Also available with chromium plated legs.

- 3 **THE LONGFELLOW** (B-3280 H), 22" x 14", shelf back, wall pattern, with soap depression. A great space saver due to its narrow front-to-back dimensions.
- 4 **THE WHITMAN** (B-3370 H), 24" x 20", ledge back, with chromium legs and towel bars, soap depression.
- 5 **THE WHITTIER** (B-3270 HT), 22" x 18", shelf back, chromium legs and towel bars, soap depression.

## LINE OF

# Beautyware CHINA LAVATORIES Low Prices!

### Points of superiority in Briggs Beautyware vitreous china lavatories:

- Ample shelf space—"beaded ends and back"—prevent side soiling.
- Double front corner concealed overflows with smooth underbowl front—no unsightly bulge—installation made easier—no cramped quarters.
- Deep anti-splash rim—non-splash with valves open.
- Deep bowl—greater water capacity.
- Special safety-wall-locking feature—"fixture cannot come off hangers".
- No-slip hexagonal towel bars—attached to lavatory, front and back.
- Special easy-fastening methods for towel bars and legs.
- Attractive fittings—hug the back—black index supply handles—quick opening valves.
- Priced right—smaller premium for color.

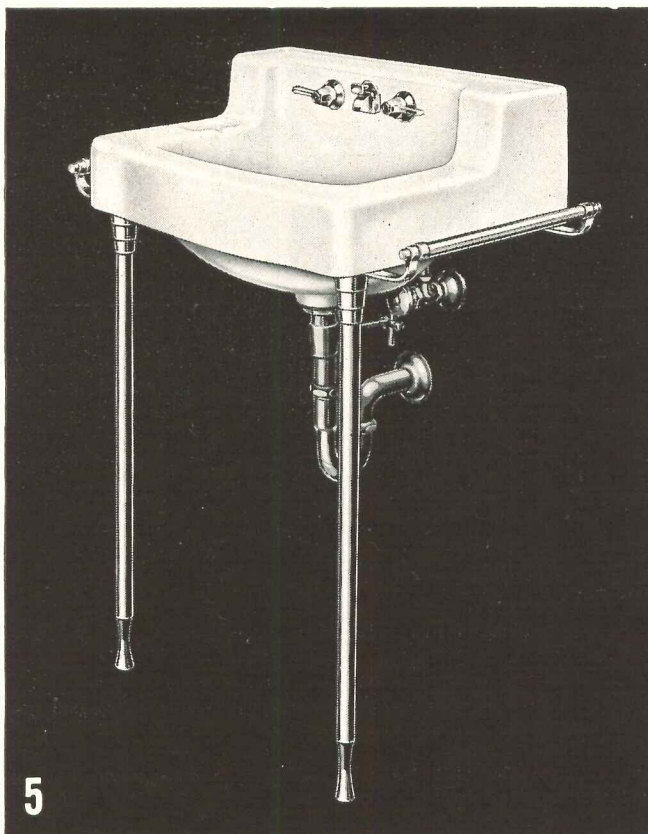
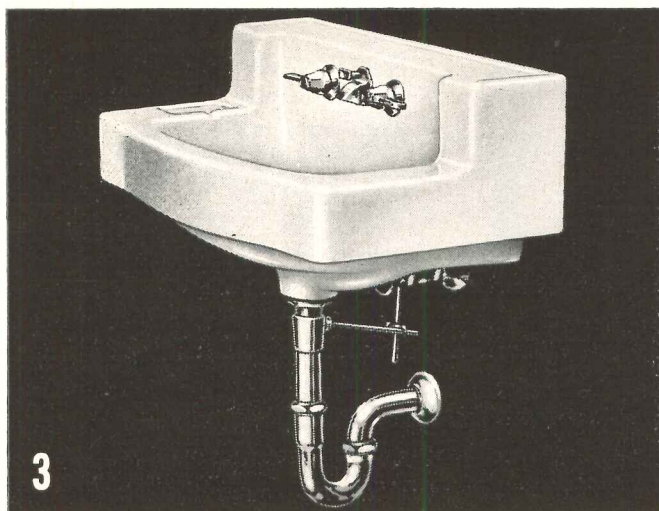

Copyright 1949, Briggs Manufacturing Co.

Write for complete details to  
BRIGGS MANUFACTURING CO.  
3031-f Miller Avenue, Detroit 11, Mich.

# BRIGGS *Beautyware*

# FIBERGLAS ROOF INSULATION

*A Lifetime Material  
at a competitive price*



- **Virtual immunity to moisture.** Will not rot or decay. In an accelerated wet and dry, hot and cold cycle weathering test by an independent laboratory, Fiberglas Board, after the equivalent of 75 years of such weathering, retained the characteristics of a satisfactory insulation.

- **Exceptionally low thermal conductance** of Fiberglas\* Roof Insulation contributes to interior comfort, to heating and air conditioning economy. Permits use of minimum thickness for any desired degree of protection.

- **Dimensional stability.** Fiberglas Roof Insulation will not swell, shrink, warp or buckle. This combination of desirable characteristics provides a firm, dependable base for a built-up roof.

- **Low weight.** Weighs only 1.31 lbs. per square foot in 1" thickness; adds no significant dead load to the structure.

- **Competitive cost.** Fiberglas Roof Insulation is competitive in price with most ordinary materials, costs no more to install.

Whenever you want these qualities, you can specify Fiberglas with complete confidence.

## ROOF DATA ON THE... PRUDENTIAL BUILDING, LOS ANGELES, CALIF.

- Architects: Walter Wurdeman and Wilton Beckett
- General Contractor: William Simpson Construction Co.
- Roofing Contractor: Pioneer Roof Company
- Roof Deck: Concrete
- Slope: Flat deck
- Roof Insulation: Fiberglas Roof Insulation. 95,000 square feet of 2" thick material.
- Roofing: 4-ply 15# and gravel.



### "The Design of Insulated Roofs"

If you do not have a copy of this 36-page reference manual, A.I.A. File No. 37, write us today. Owens-Corning Fiberglas Corporation, Dept. 831, Toledo 1, Ohio. In Canada: Fiberglas Canada Ltd., Toronto, Ontario.

OWENS-CORNING  
**FIBERGLAS**  
TM. REG. U.S. PAT. OFF.

**BUILDING  
MATERIALS**

\*FIBERGLAS is the trade-mark (Reg. U. S. Pat. Off.) of Owens-Corning Fiberglas Corporation for a variety of products made of or with glass fibers.



HERE convenient switch gives complete On-Off control



HERE, too, independent On and Off switching

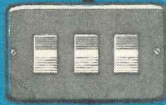

and HERE, complete control of remote light



HERE, a small G-E remote-control relay does the work

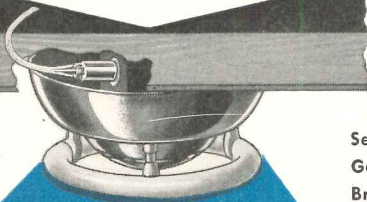

# Now, add dream-home lighting at budget-home cost!

## Exciting, New General Electric Remote Control Wiring System Makes Multi-point Switching Practical, Economical

**Convenience unlimited!** That's General Electric's new wiring system—G-E remote control—the new design for electrical living that lets you plan downright ease for your most budget-minded clients.

With G-E remote control the homeowner no longer makes his nightly trip to check the cellar lights. He just pushes a button—in the living room, in the hall, or even in the bedroom—and he knows that troublesome cellar light is out. Garage lights, outside lights, the attic fan—all can be turned On or Off anywhere and everywhere in the house that's wired with the General Electric remote control wiring system. And, in every room, multi-point switching can put control of the lights in that room at every entranceway, even next to easy chairs or other convenient spots. And the really amazing part of the remote control story is that it's designed to go in easily and economically.

You owe it to yourself to find out about the General Electric remote control wiring system. Get the facts and talk them over with your electrical contractor . . . mail the coupon now for complete details on this important development.

Section D32-65  
General Electric Company  
Bridgeport 2, Connecticut

Please send me your free bulletin on the new General Electric remote control wiring system.

Name \_\_\_\_\_ Title \_\_\_\_\_

Company \_\_\_\_\_

Address \_\_\_\_\_

City \_\_\_\_\_ Zone \_\_\_\_\_ State \_\_\_\_\_

Mail  
Coupon  
Now!

GENERAL  ELECTRIC

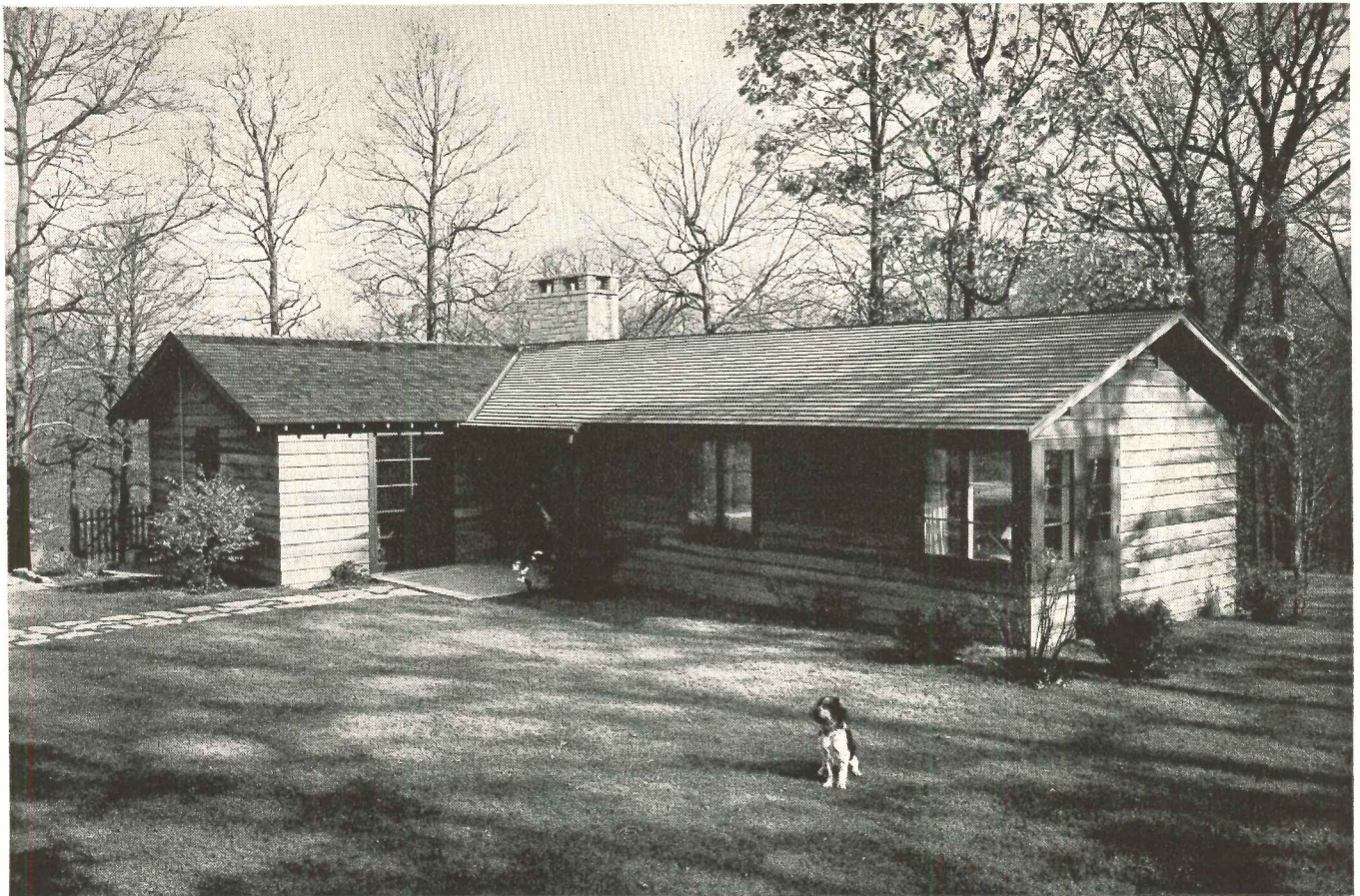

*Perkins & Will and Edwin H. Mittelbush, Architects*

## TELEPHONE RACEWAYS FIT INTO THE SCHEME OF THINGS

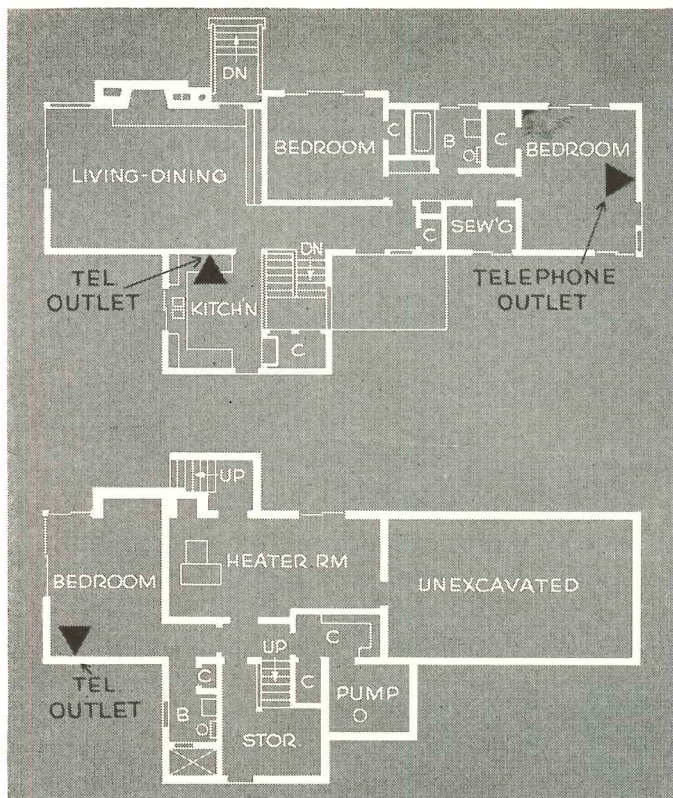

Most new homes today are a blend of beauty and utility — everything in its proper place. And the proper place for telephone wires is out of sight.

It's a simple job to conceal telephone wires within walls. A few lengths of pipe or tubing, installed during construction, will keep them from being exposed on walls and woodwork. All that shows are neat telephone outlets, located where they will be most convenient for the owner.

For homes of any size, your Bell Telephone Company will be glad to help you plan modern telephone arrangements. Just call your Telephone Business Office and ask for "Architects and Builders Service."



**BELL TELEPHONE SYSTEM**



# YOU'RE RIGHT "ON THE LINE" —when you turn to Wheeling!

Survey the field and you'll find quality and satisfaction in these products that bear the famous Wheeling Red Label. Write us for complete information.

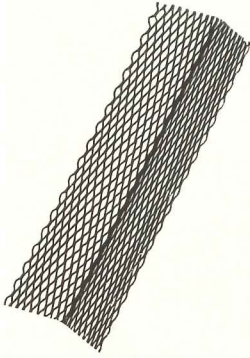

### WHEELING CORNERLATH

New. A reinforced selvage edge cornerlath for all plastered inside corners.

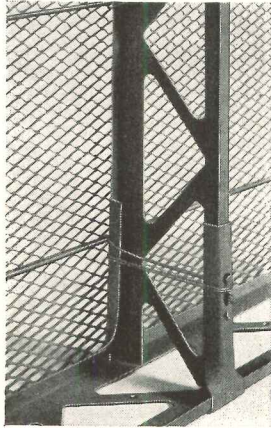

### WHEELING BAR-Z PARTITIONS

Its few unit parts quickly assemble into non-bearing hollow plastered steel stud and metal lath partitions or free-standing wall furring.

### WHEELING DIAMOND LATH

Flat, perfectly straight sheets with parallel sides. Stiff. Impervious to rust.

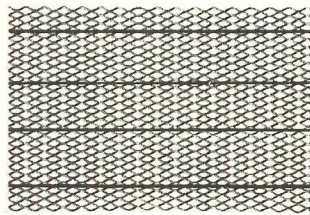
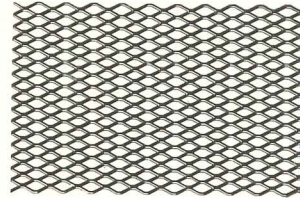

### WHEELING BAR-X-LATH

Stands stiff to the trowel, handles easier, faster, needs no stretching. Four pairs of No. 11 rods are welded through the mesh for reinforcement.



### WHEELING TRI-RIB ROOF DECK

Assembles quickly at low cost, in continuous lengths up to 22' 6". Cop-R-Loy steel resists rust and corrosion.



### WHEELING FLEXBEAD

Easy to plaster—curves to fit corners and arches. Wheeling Flat Apron Corner Bead makes true, protected exposed plaster corners.

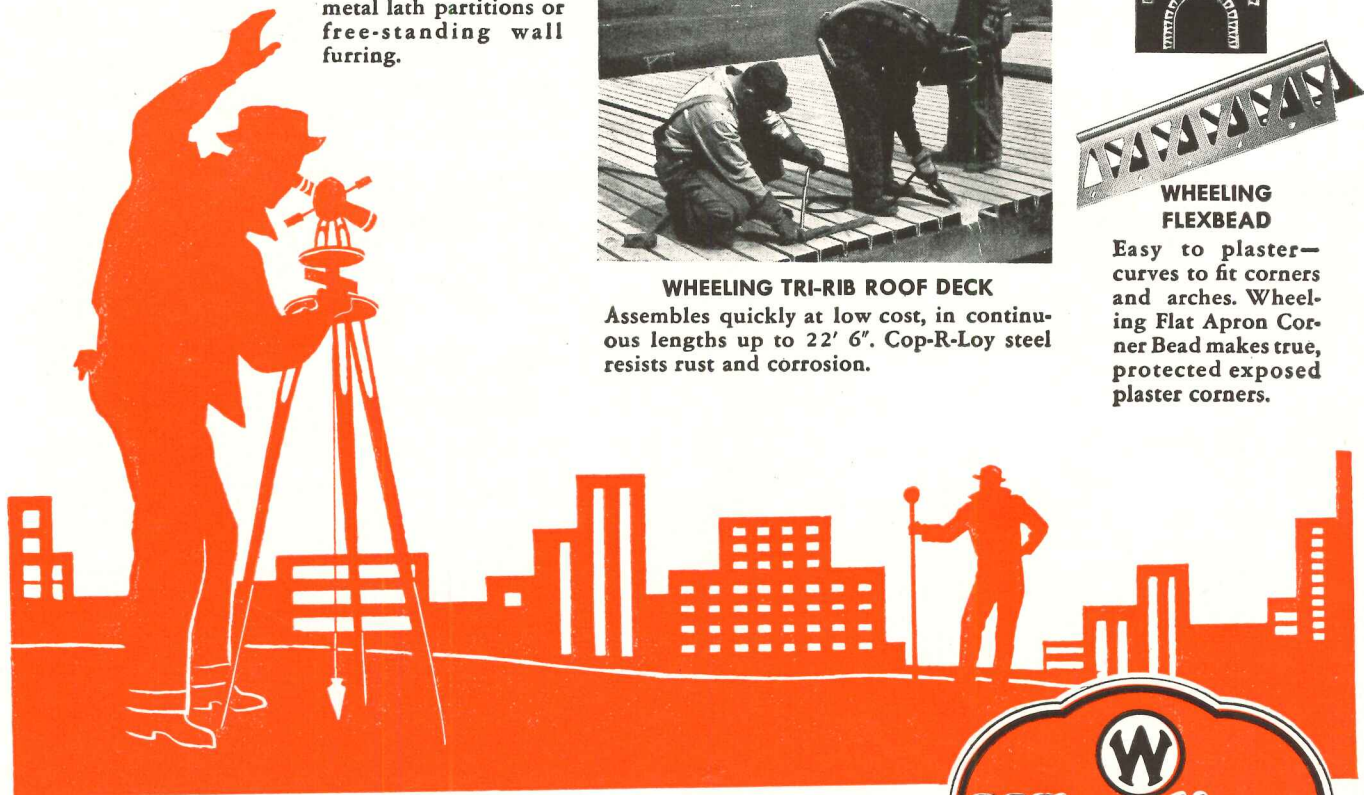

**WHEELING CORRUGATING COMPANY**  
**WHEELING, WEST VIRGINIA**

Atlanta • Boston • Buffalo • Chicago • Cleveland • Columbus • Detroit • Kansas City  
Louisville • Minneapolis • New Orleans • New York • Philadelphia • Richmond • St. Louis



# How *Glass* is being used to

"THE MATERIAL of a thousand uses"—that's how someone referred to Pittsburgh Corning Glass Blocks. And for good reasons! They combine modern good looks with exceptional versatility. They transmit daylight generously. They preserve privacy. They aid in temperature control. And they can be used to create striking decorative effects. Architect: Henry Slaby, Milwaukee, Wisconsin.

PITTSBURGH POLISHED PLATE GLASS in this unusual cage at the St. Louis Zoo provides visitors with perfect vision of the interior. Wherever accurate vision is important, you can be sure of satisfaction by specifying Pittsburgh Plate Glass. And if it's Pittsburgh Plate Glass you can be sure it's the finest made. Architect: J. E. Wallace.

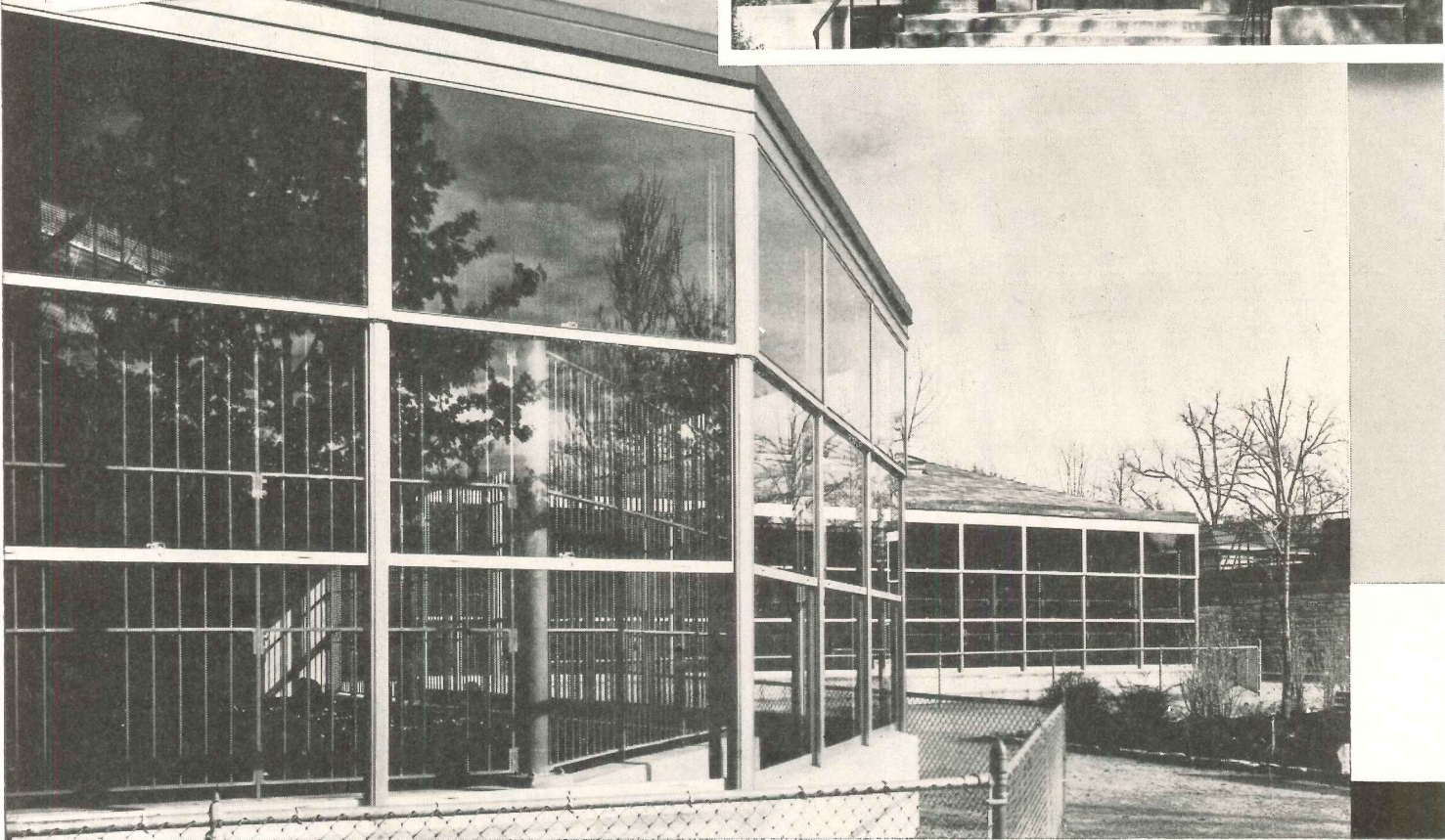
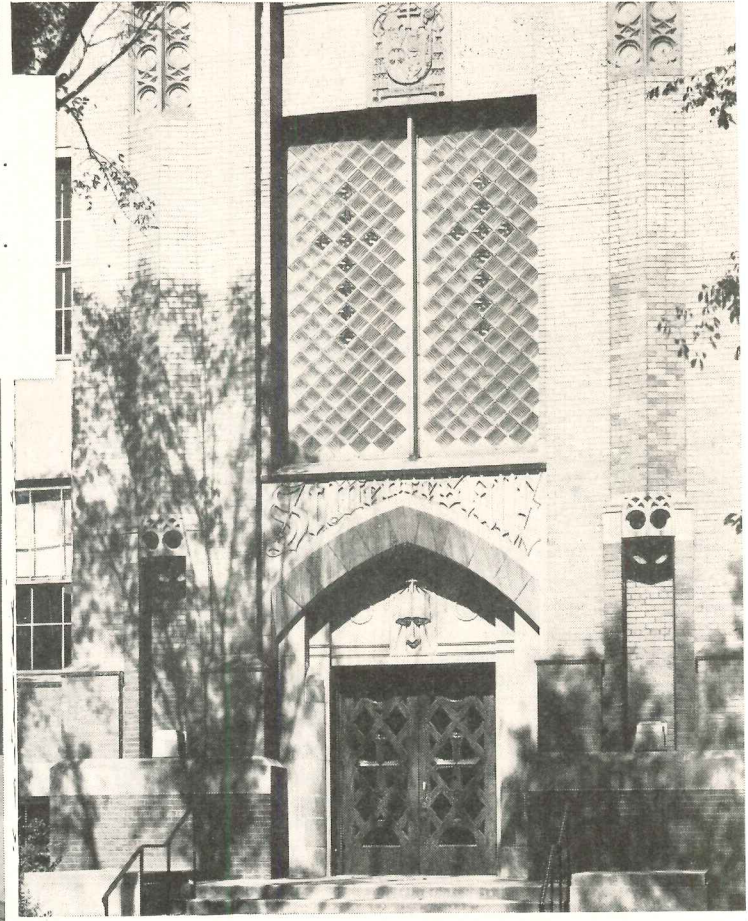

# advantage in Public Buildings



PITTSBURGH X-RAY LEAD PLATE GLASS offers protection against continuous exposure to X-rays. It also allows clear vision of equipment and the patient. This glass which may be used both for interior and exterior glazing has a lead content of approximately 61% and a lead equivalent value of .32 as determined by the National Bureau of Standards. Architects: Coolidge, Shepley, Bullfinch & Abbott, Boston, Mass.

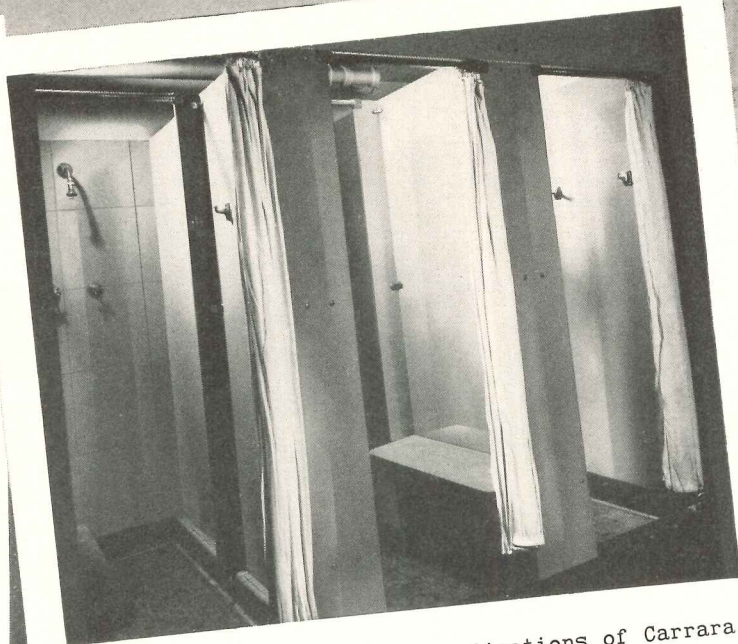

THE CONSTANTLY INCREASING applications of Carrara Structural Glass are indicative of its many outstanding qualities. This exceptionally good-looking structural glass is impervious to moisture, chemicals and to pencil marks. It will not fade or stain or absorb odors. It doesn't check, craze or warp. Has no lippage at joints. And it can be cleaned in a jiffy with nothing more than a damp cloth. There are ten pleasing colors of Carrara Glass to choose from. Architect: Press C. Dowler, Pittsburgh, Pa.

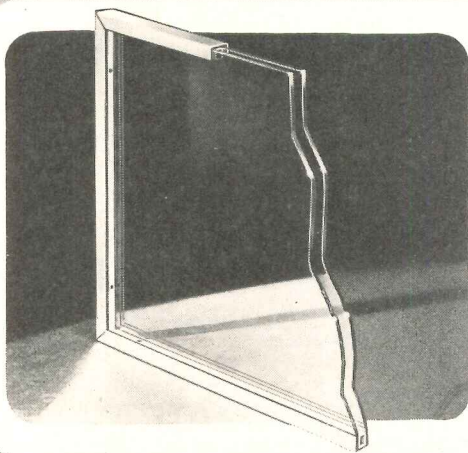

THE STAINLESS STEEL CHANNEL around each double-glazed Twindow unit is the result of a tremendous amount of research in "Pittsburgh" Laboratories to determine the best way to protect the unit against breakage and edge damage in the field. This exclusive Twindow feature simplifies handling of the unit. It makes it easier and safer to install. This research work is typical of "Pittsburgh's" 66-year-old program of product improvement—a program which has resulted not only in improved quality of "Pittsburgh" products, but in better performance of these products.

See the complete listing and descriptions of Pittsburgh Plate Glass Company products in Sweet's Catalog Files.



★ Design it better with

## Pittsburgh Glass

PAINTS • GLASS • CHEMICALS • BRUSHES • PLASTICS

PITTSBURGH PLATE GLASS COMPANY

# ELECTRUNITE E.M.T.

...the ORIGINAL lightweight rigid steel wiring raceway

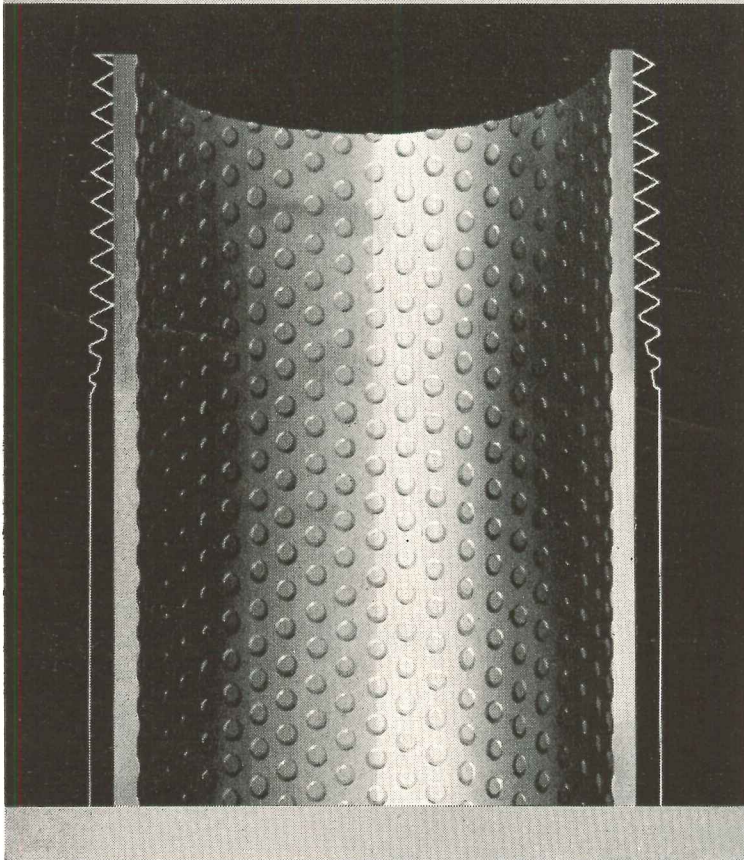

*The wall thickness of Republic ELECTRUNIT E.M.T. (electrical metallic tubing) was not arrived at by guesswork! It was carefully and scientifically determined by Steel and Tubes. Subsequent tests by a recognized fact-finding board have proved that it provides adequate mechanical and electrical protection throughout the installation.*

SEE SWEET'S FILE  
or write us for detailed information on these Republic Steel Building Products:  
Pipe—Sheets—Roofing  
Enduro Stainless Steel  
Toncan Enameling Iron  
Electrunite E.M.T.  
Fretz-Moon Rigid Steel Conduit  
Taylor Roofing Ternes  
Berger Lockers, Bins, Shelving  
Berger Cabinets for Kitchens  
Truscon Steel Windows, Doors, Joists  
and other Building Products

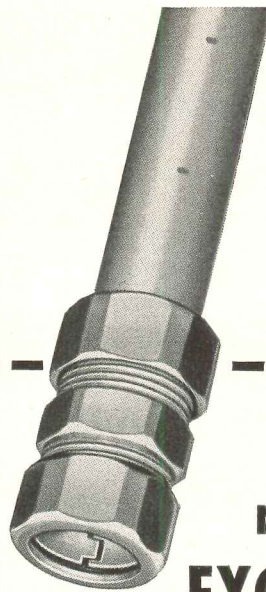

NEEDS NO  
**EXCESS METAL**  
TO ACT AS A BASE FOR  
**Thread-Cutting**

Here's the BIG DIFFERENCE between Republic ELECTRUNIT E.M.T. and heavy threaded conduit. With threaded conduit, there must be excess metal to act as a base for threads and still leave adequate wall thickness underneath. Because modern ELECTRUNIT E.M.T. is *threadless*, it does not require excess metal . . . its adequate wall thickness is uniform throughout every length . . . its unbroken coating of protective zinc provides continuous protection against rust and corrosion.

From an installation standpoint, too, ELECTRUNIT E.M.T.'s lighter weight means important cost-saving advantages: easier handling . . . easier installation in hard-to-reach locations . . . easier, more accurate bending . . . fewer delays on the job.

For raceways that are exposed, concealed or in concrete, you can't beat ELECTRUNIT E.M.T. Get all of the facts from your nearest Steel and Tubes Representative . . . or write to:

REPUBLIC STEEL CORPORATION  
STEEL AND TUBES DIVISION • CLEVELAND 8, OHIO  
Export Department: Chrysler Building, New York 17, New York

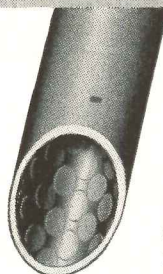

Republic



**ELECTRUNITE E.M.T.**

REG. U.S. PAT. OFF.

# HAVE YOU TRIED BRIXMENT —FOR STUCCO AND PLASTER?



Speed Memorial Church, Speed,  
Indiana  
Architects: Nevin, Wischmeyer  
and Morgan  
Contractors: Minter Homes Cor-  
poration  
Brixment used exclusively for ex-  
terior stucco and interior plaster

**T**his beautiful little church was stuccoed and plastered with *Brixment* — in 1924!

Today, 25 years later, the *Brixment* plaster and stucco are still in perfect condition.

*Brixment* has just as many advantages for *stucco and plaster* as for masonry. It works smoother and easier, has a more convenient hardening time, resists moisture and weathering. Since the great plasticity of *Brixment*

permits leaner mixes, it eliminates or greatly reduces hair-checking and crazing. It is mixed and applied like Portland-cement stucco *except that no lime is required.*

If you are one of the thousands who know and prefer *Brixment* for *masonry*, we enthusiastically recommend *Brixment* to you, for *stucco and plaster*. Ask your dealer, or write us direct, for a copy of the handbook, "*Brixment for Stucco and Plaster.*"

**LOUISVILLE CEMENT COMPANY, Incorporated, LOUISVILLE, KENTUCKY**

# These New Construction Methods

*help keep you within the budget*

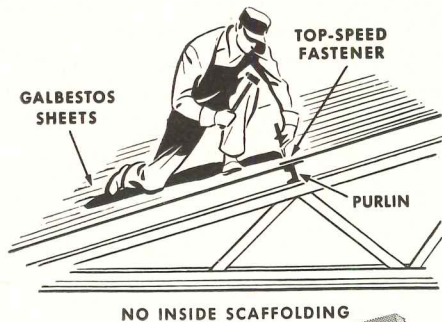

The only way to keep costs down in the face of rising materials and labor prices is to use timesaving methods and construction materials.

**1** **TOP-SPEED FASTENING\*** is a faster method of attaching roof and side to steel framework. It results from a new group of tools, Top-Speed Fasteners. *This system is so fast that the same number of men in the same time can apply twice as much material.* All work is done entirely from the top-side, eliminating all interior scaffolding. Write for the booklet that explains in detail the great saving of Top-Speed Fastening.



**2** **GALBESTOS** is protected sheet steel. The details of its unique construction are explained in the box below. Please note here that you should familiarize yourself with Galbestos because its use reduces the number of purlins, reduces the amount of structural steel needed. Also, it requires no painting and is so durable that maintenance is virtually eliminated. The choice of colors and surfaces of Galbestos provides you a chance to get new design into industrial buildings. Write for the facts on how Galbestos reduces cost of roof and sides.

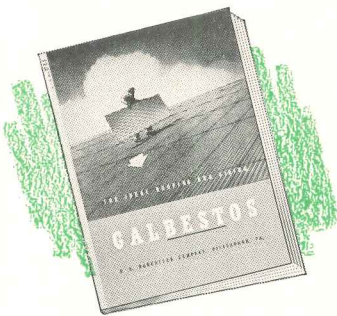

**Galbestos is listed and classified by Underwriters' Laboratories and the Associated Factory Mutual Laboratories**

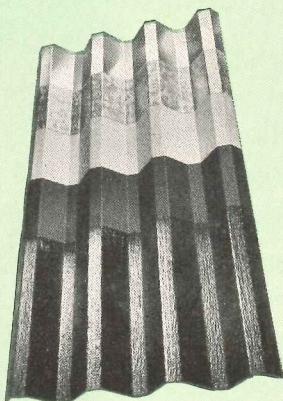

Lock your fingers like this picture. It will give you an idea of how asbestos fibers are locked into the very core metal of Galbestos. We call this bond the Galbestos Grip. It is a unique development of Robertson research.



So inseparable is the bond that Galbestos can be worked on ordinary sheet-metal shop equipment. By *worked*, we mean crimped, rolled, sheared, bent and riveted like unprotected metal.



Asbestos is fused to sheet steel by a metallic alloy. The myriad rock-born fingers are literally imbedded in metal. The asbestos is impregnated with asphalt and waterproofed.



Galbestos comes in standard roofing and siding sheets up to 12 feet by 33 inches; maroon or black finishes; flat or in several corrugations; for use over steel skeleton framework. Would you like to see samples?



# Lower Costs

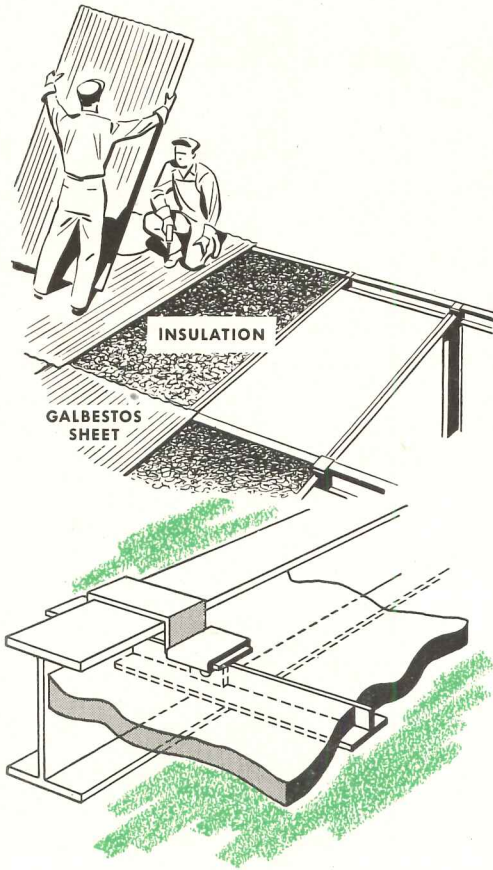

**3** **TOP-SPEED INSULATION\*** is a structural method developed by Robertson in which insulation can be applied entirely from the outside just before the roofing or siding is applied. Insulation is being required for industrial buildings as never before. Note this: if you build with Top-Speed Fastening and Top-Speed Insulating, you save so much labor cost that it pays for the labor of installing insulation. Therefore, you can insulate merely for the cost of the material. Robertson uses insulation which has good acoustical value. No straps or other fasteners mar the appearance. It can be painted but it makes such a good-looking, smooth job that many owners leave it unpainted. Write for the booklet on Top-Speed Insulation.

**4** **ROOF DESIGN** can directly reduce cost. An independent engineering study performed on six roof designs has proved that some roofs reduce over-all building costs more than others. This study compiled figures on amount of steel required, labor, erection time, maintenance. It considered every factor: such details as alternate materials; maximum use of natural daylighting; maximum use of gravity ventilation. This complete study—an original contribution to construction knowledge—is now the exclusive possession of the Robertson Co. Write for your copy of the complete compiled work.

All figures are based upon the true and available costs of today. They will help you make estimates that stick. Write for your copy.

\*Patent Pending

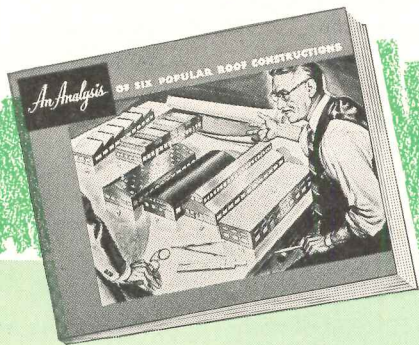

## H. H. ROBERTSON CO.

2404 Farmers Bank Building  
Pittsburgh 22, Pennsylvania



Offices in 50 Principal Cities  
World-Wide Building Service

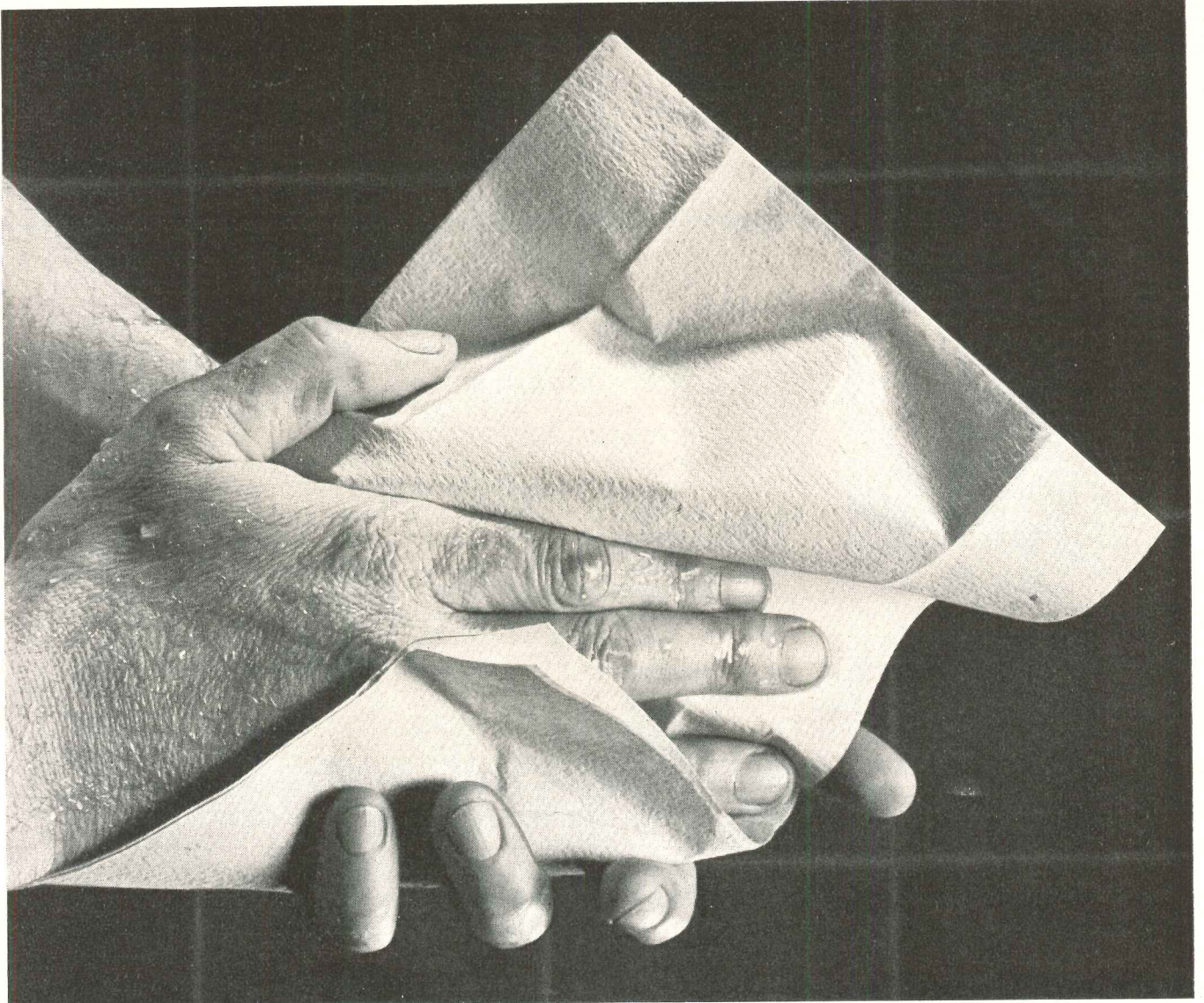

Washrooms rank as one of the four most important factors in good working conditions—according to a survey of workers from 400 plants.

In these hands...  
evidence of a  
"good place to work"

Washrooms can have quite a bearing on whether or not a company is a "good place to work." Don't you feel annoyed when you enter a washroom that isn't what it should be?

Clean, modern, *carefully planned* washrooms are evidence of intelligent, thoughtful management. You're doing your client a real favor when you make sure his washrooms *are* right.

ScotTissue Towels are a symbol of the right kind of washroom. Include ScotTissue Towel cabinets in your washroom planning. Send for our free booklet that's filled with helpful suggestions, well-tested plans and diagrams (written by an architect specializing in this field) for both large and small washrooms, locker rooms, etc. Write to the Scott Washroom Advisory Service, Chester, Pennsylvania.

Trade Marks "ScotTissue," "Washroom Advisory Service," Reg. U. S. Pat. Off.



## SCOTTISSUE TOWELS

Symbol of the right kind of washroom

Pittsburgh  
**COLOR  
DYNAMICS**

*utilizes the energy  
in color to reduce  
eye fatigue and  
increase efficiency  
among office  
workers.*

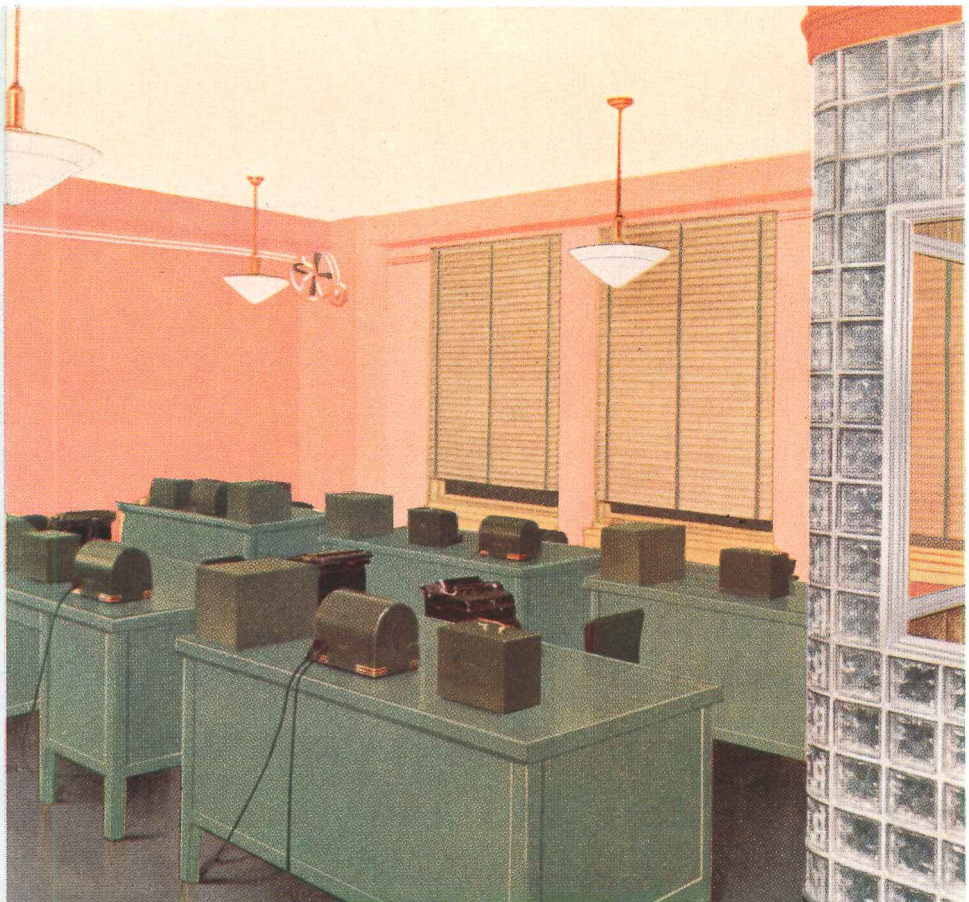

## Free . . . COLOR DYNAMICS Survey for buildings you plan

**H**ow does the use of cool, refreshing color upon walls reduce eye fatigue and stimulate energy among office workers?

Why does an office on one side of the building require one kind of color treatment to increase the efficiency of those who use it while rooms on the other side of the hall require different colors?

**How can the** right color arrangement more accurately reflect the character and integrity of a business or professional organization?

Pittsburgh's system of COLOR DYNAMICS answers these and many other painting questions. This new system of decoration is based upon the fundamental principles of the *energy in color*. Color is a source

of energy. It can help people to be cheerful and energetic or cause them to feel uncomfortable and depressed.

**Pittsburgh technicians** have used these principles as the basis of COLOR DYNAMICS which enables you to utilize color for functional as well as decorative purposes. Now you can specify color arrangements which are not only good to look at but which promote efficiency and better morale in an organization.

We'll be glad to make a scientific COLOR DYNAMICS *engineering survey* of the buildings you are now planning or erecting—free and without obligation on your part. Send for the interesting booklet which describes this painting method and how it works.

### There's a Pittsburgh Paint For Every Painting Need

**WALLHIDE**—PBX, extra-durable; SEMI-GLOSS, for higher sheen; FLAT, for velvet-like finish; GLOSS, for severe service and frequent cleaning.

**LAVAX PBX ENAMEL**—durable finish for interior use. Dries quickly to an eggshell finish that eliminates glare. For wood, metal or other surfaces.

**FLORHIDE**—for floor surfaces; can be scrubbed repeatedly with soap solutions.

Pittsburgh Plate Glass Co., Paint Div.  
Dept. AR-69, Pittsburgh 22, Pa.

Please send me a FREE copy of your new revised and enlarged Booklet, "Color Dynamics."

Please have your representative call for a Color Dynamics Survey without obligation on our part.

Name \_\_\_\_\_

Street \_\_\_\_\_

City \_\_\_\_\_

County \_\_\_\_\_ State \_\_\_\_\_

FREE BOOKLET! ➔

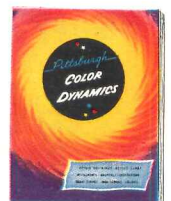

**PITTSBURGH PAINTS**

PAINTS • GLASS • CHEMICALS • BRUSHES • PLASTICS

PITTSBURGH PLATE GLASS COMPANY

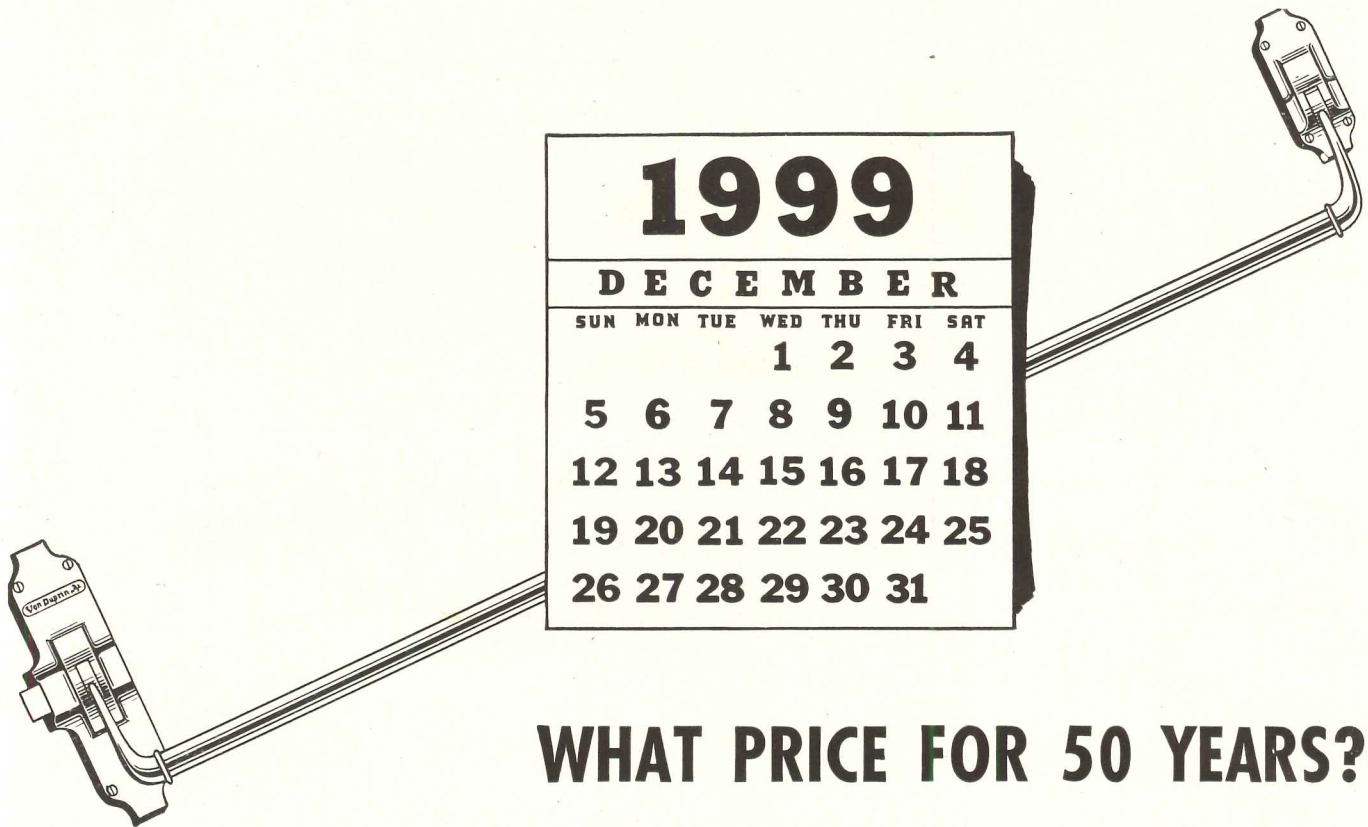

## WHAT PRICE FOR 50 YEARS?

In 1999 the drop-forged Von Duprin panic exit devices put on the doors in '49 will still be providing safe exit—quick, easy and sure.

They will have given the utmost in safety at little or no cost for maintenance. The first cost will have been virtually the only cost; the cost per year almost unbelievably low. Yet the Von Duprins will still show the beauty of their precision manufacture, the quality of the fine metals of which they are forged. They will be ready to deliver outstanding safety in the years ahead.

That's why drop-forged Von Duprins are 1949's big value in the panic exit device field.

VON DUPRIN DIVISION  
VONNEGUT HARDWARE CO., INDIANAPOLIS 9, INDIANA

# Von Duprin

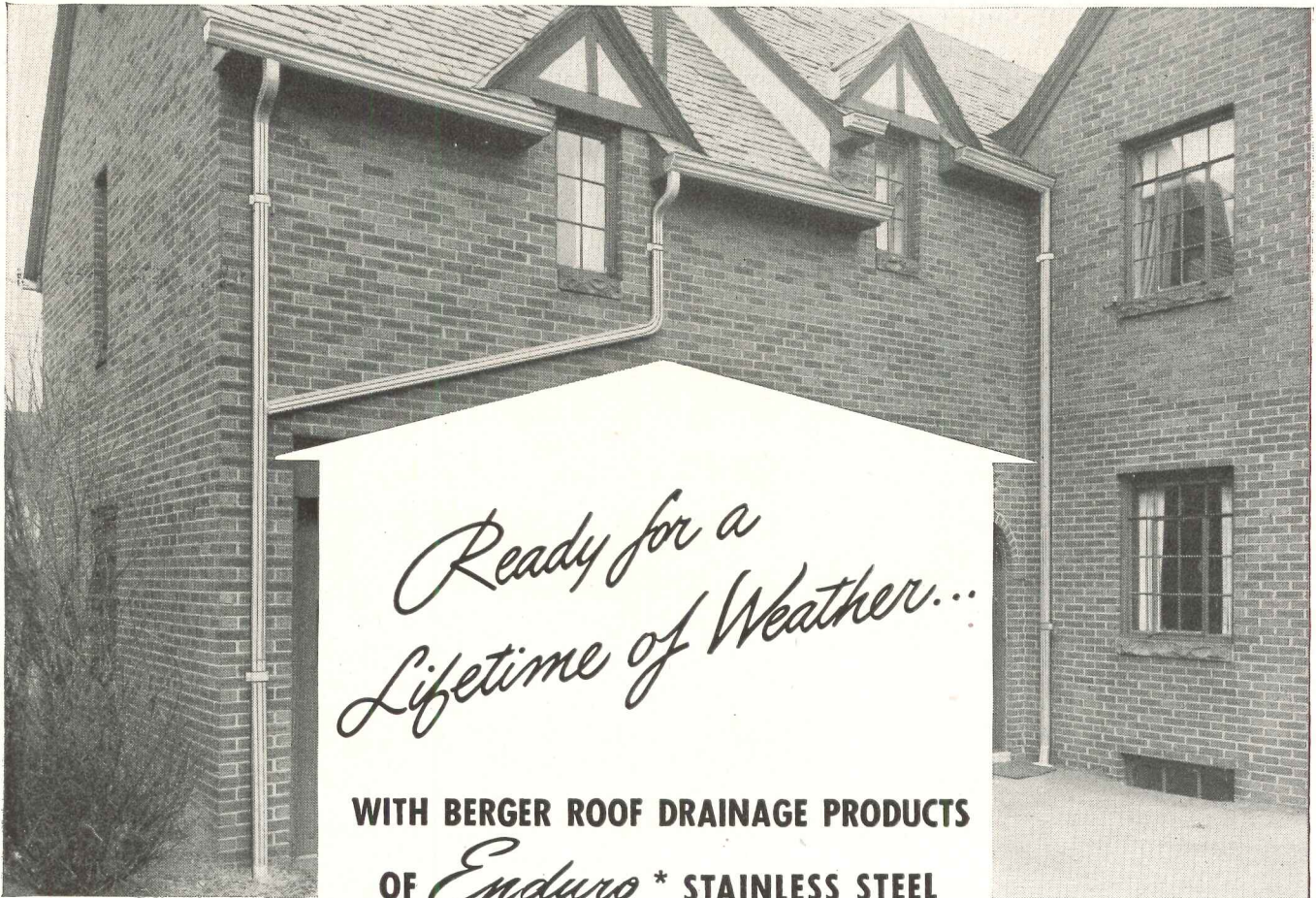

*Ready for a  
Lifetime of Weather...*

**WITH BERGER ROOF DRAINAGE PRODUCTS  
OF *Enduro*\* STAINLESS STEEL**

North, south, east or west . . . no home escapes the ravages of weather. Roof drainage systems particularly are exposed. But, when made up of weather-resistant Berger Roof Drainage Products of ENDURO Stainless Steel, they can escape the damaging effects of ice, snow, sleet, rain, freezing cold and blistering heat.

Republic ENDURO Stainless Steel "gets along well" with weather . . . and with corrosive industrial atmospheres, too. It does not rust or tarnish . . . retains a soft, natural beauty through the years. Its high strength enables it to

stand up under heavy loads of ice and snow. It withstands severe temperature changes without expansion cracking or buckling. It resists abrasion and denting . . . does not bleed or discolor paint . . . requires little or no maintenance . . . lasts for the life of the building . . . costs your client less in the long run.

Service-wise or price-wise, there's no need today for specifying less satisfactory materials. Build for a lifetime of weather with light, weathertight Berger Roof Drainage Products made of Republic ENDURO Stainless Steel.

*Berger*



**Manufacturing Division**

REPUBLIC STEEL CORPORATION • CANTON 5, OHIO

Warehouses in BOSTON, PHILADELPHIA and ST. LOUIS • Sales Offices in DETROIT, MICH., and INDIANAPOLIS, IND.

*Berger Stainless Steel Roof Drainage Products include Snap-tite Eaves Trough; "K" Gutter; Plain Round, Corrugated Round and Corrugated Square Conductor Pipe; plus a complete line of all necessary fittings. All are made of 28-gauge Republic ENDURO Stainless Steel, type 301, No. 2, satin finish.*



\*Reg. U. S. Pat. Off.

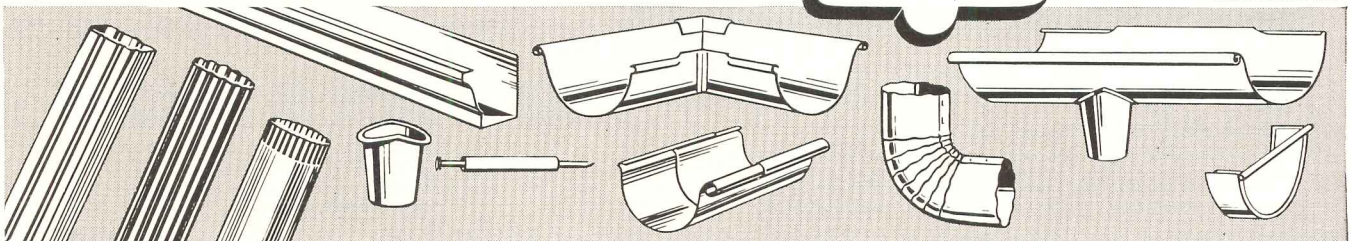

# Better Seeing for Better Selling



...for Brunwood Motors, Worcester, Mass.

Sleek, graceful lines of these Lincoln cars are emphasized by the longitudinal reflections from Litecontrol fixtures that parallel all display windows. For extra accent, strategically placed lens boxes add sparkle and life to the chrome fittings.

Consulting Engineer: R. E. Lupien . Electrical Contractor: Coghlin Electric Company . Lighting Equipment: Litecontrol No. 9134 recessed lens fixture with 3 lamps and supplementary 250 watt accent lights . Lamps: 40 watt, 3500 degree, white, fluorescent; 250 watt incandescent . Wattage per fixture: 150-fluorescent; 250-incandescent . Total Wattage: 7,600 . Watts per Square Foot: 5.4 . Footcandles: 80 Initially.

Every one of the many Litecontrol fixtures are good to look at — graceful and glare-free. Yet they are capable of putting plenty of lighting punch on working or selling areas. Extra sturdy in construction — easy to install — Litecontrol fixtures are also built for faster cleaning and easier servicing.

Litecontrol engineers are specialists in building sales through better lighting. And they'll be glad to help you with advice — or by furnishing complete lighting layouts. With their technical assistance you can help your customers sell more goods — help yourself sell better lighting to more customers.

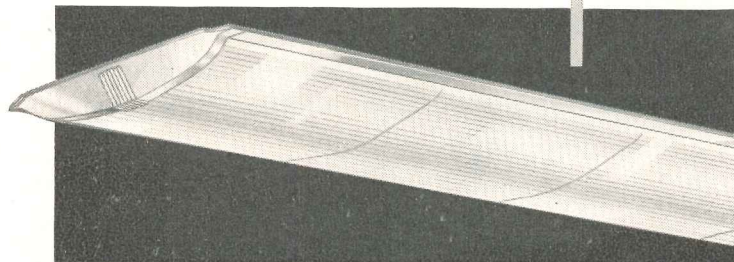

## ...with LITECONTROL FIXTURE NO. 9134

Selected for this automobile showroom was a Litecontrol flush, troffer-type unit using Holophane Controlescent curved lenses. Its optical engineering gives excellent light distribution and reduced contrast between fixture and ceiling. Smooth graceful lines and shallow recess depth blend pleasingly into any modern architectural design.

Cat. No.	No. of Lamps	HOUSING			TRIM		Weight
		Length	Width	Height	Length	Width	
9124	2-40W	48"	13 3/4"	5 3/8"	49 1/2"	14 3/4"	46 lbs.
9134	3-40W	48"	13 3/4"	5 3/8"	49 1/2"	14 3/4"	51 lbs.

End Cap — No. 9100-3. Suspension Strap — No. 9100-6

LITECONTROL CORPORATION  
36 PLEASANT STREET, WATERTOWN 72, MASSACHUSETTS

DESIGNERS, ENGINEERS AND MANUFACTURERS OF FLUORESCENT LIGHTING EQUIPMENT DISTRIBUTED ONLY THROUGH ACCREDITED WHOLESALERS



LITECONTROL  
*Fixtures*

KEEP UPKEEP DOWN

# Jenkins PRACTICAL PIPING LAYOUTS 42

## How to plan OIL BURNER PIPING FOR LIGHT OILS

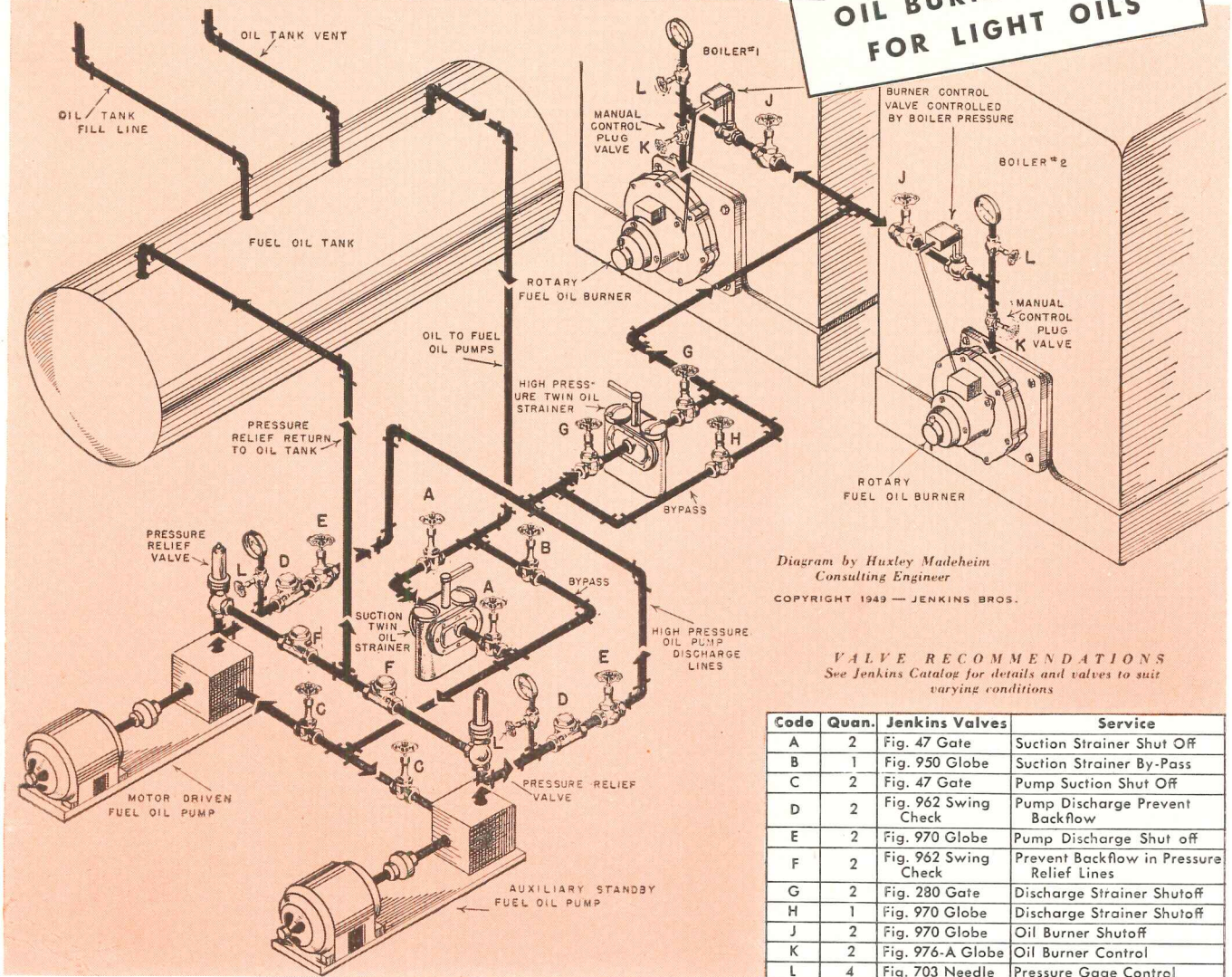

Diagram by Huxley Madeheim Consulting Engineer  
COPYRIGHT 1949 — JENKINS BROS.

**VALVE RECOMMENDATIONS**  
See Jenkins Catalog for details and valves to suit varying conditions

Code	Quan.	Jenkins Valves	Service
A	2	Fig. 47 Gate	Suction Strainer Shut Off
B	1	Fig. 950 Globe	Suction Strainer By-Pass
C	2	Fig. 47 Gate	Pump Suction Shut Off
D	2	Fig. 962 Swing Check	Pump Discharge Prevent Backflow
E	2	Fig. 970 Globe	Pump Discharge Shut off
F	2	Fig. 962 Swing Check	Prevent Backflow in Pressure Relief Lines
G	2	Fig. 280 Gate	Discharge Strainer Shutoff
H	1	Fig. 970 Globe	Discharge Strainer Shutoff
J	2	Fig. 970 Globe	Oil Burner Shutoff
K	2	Fig. 976-A Globe	Oil Burner Control
L	4	Fig. 703 Needle	Pressure Gage Control

Light and medium fuel oils, numbers 1, 2, 3 and 5 (cold), which do not require pre-heating can be handled in a hookup as shown here. Since the expense of a pre-heater installation can be eliminated, this relatively simple system is economical and easy to operate.

Fuel oil flows through a large mesh, twin-type strainer to a motor driven pump which provides the necessary oil pressure for satisfactory operation. The oil then passes through another fine mesh strainer, which removes any small particles that might clog the burner.

Although one fuel pump can adequately handle the maximum boiler demands, two

are recommended to provide a second pump for standby service in case of breakdown. Each pump is provided with a pressure relief valve as a protection against excessive oil pressure.

Consultation with accredited piping engineers and contractors is recommended when planning any major piping installation.

**A CHOICE OF OVER 500 VALVES**  
To save time, to simplify planning, to get all the advantages of Jenkins specialized valve engineering experience, select all the valves you need from the Jenkins Catalog. It's your best assurance of lowest cost in the long run.

Jenkins Bros., 80 White Street, New York 13; Bridgeport, Conn.; Boston; Philadelphia; Chicago; San Francisco; Atlanta. Jenkins Bros., Ltd., Montreal.

LOOK FOR THIS  DIAMOND MARK  
Since  1864

Reserve your copy of  
**NEW BOOK OF PIPING LAYOUTS**  
Nos. 26 to 50  
A new book of Jenkins Practical Piping Layouts — Nos. 26 to 50 — including above, is in preparation. Mail coupon to get your copy when ready.



## JENKINS VALVES

For every Industrial, Engineering, Marine, Plumbing-Heating Service . . . in Bronze, Iron, Cast Steel, and Corrosion-resisting Alloys . . . 125 to 600 lbs. pressure.

Sold Through Reliable Industrial Distributors Everywhere

JENKINS BROS., 80 White Street, New York 13, N. Y.  
Reserve copy of New Piping Layout Book for

Name.....  
Company.....  
Address.....  
.....

# marble

... unites good design  
with economy



MARBLE in the bathroom is not a luxury. In fact, taking into consideration only its first cost and its lasting qualities, it is the *least* expensive material to be had.

Moreover, Marble is completely adaptable to modern trends in planning and appointing bathrooms. When Marble is used, the bathroom is clean and inviting, and worthy of being introduced to any guest.

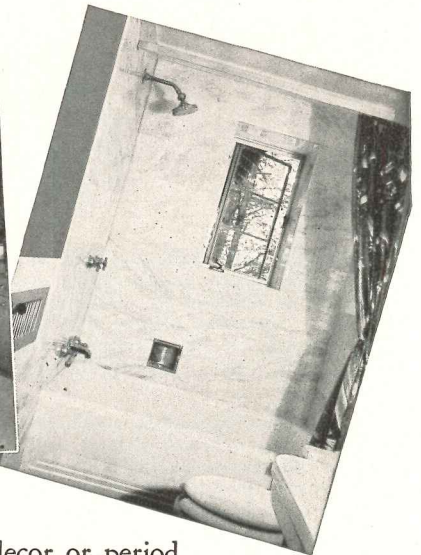
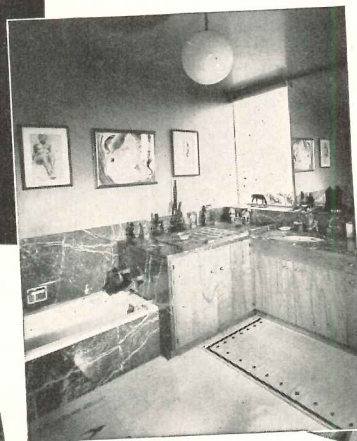
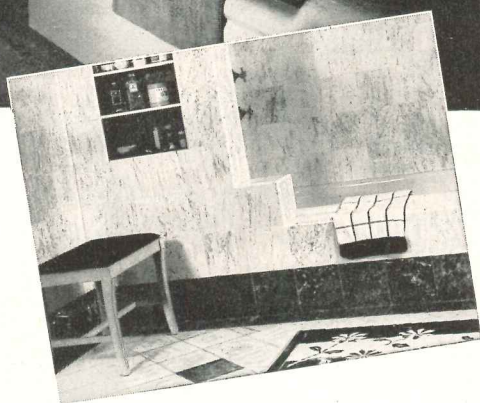

Whether with modern decor or period design, Marble is always beautiful, always an aid in maintaining sanitary conditions.

Write Managing Director  
for latest literature  
on foreign and domestic  
marbles. Dept. 29-F



**Marble Institute  
of America, inc.**

108 FORSTER AVENUE, MOUNT VERNON, N. Y.



**ANEMOTHERM**

# AIR METER



measures...

**AIR VELOCITY**

**AIR TEMPERATURE**

**STATIC PRESSURE**

*"No air conditioning system is better than its air distribution"*

- Provides vital data on the performance and efficiency of heating, ventilating and air conditioning systems.
- Detects even the slightest drafts because it is capable of accurately measuring velocities as low as 10 fpm.
- Gives instantaneous direct readings without the necessity of timing, calculation, or reference to tables or graphs.
- Non-directional — measures air velocity accurately regardless of direction of air flow . . . measures low room air velocities of a turbulent nature.

- Measures velocities without being influenced by any normal static pressures usually found in heating, ventilating and air conditioning. Particularly valuable in measuring neck velocities of air diffusers.
- Lightweight — weighs only 10 lbs. complete with "A" batteries available everywhere.
- Provides laboratory accuracy in a portable field unit.
- Can take measurements at points ordinarily inaccessible.
- Special voltage regulating circuit

provides accurate readings regardless of battery condition.

- Greater accuracy of reading is assured because the pointer is properly dampened to prevent oscillation—thus producing average readings.
- Velocity reading is self-compensated for changes in ambient temperature.
- Operates on self-contained batteries . . . is not subject to line voltage fluctuations of ordinary lighting circuits.
- Spread of the scale over multiple bands permits easier and more accurate reading.

THE ANEMOTHERM IS A DEVELOPMENT OF  
**ANEMOSTAT CORPORATION OF AMERICA**

10 EAST 39th STREET, NEW YORK 16, N. Y.

*Manufacturers of Anemostat Draftless Air Diffusers*



AC-1228

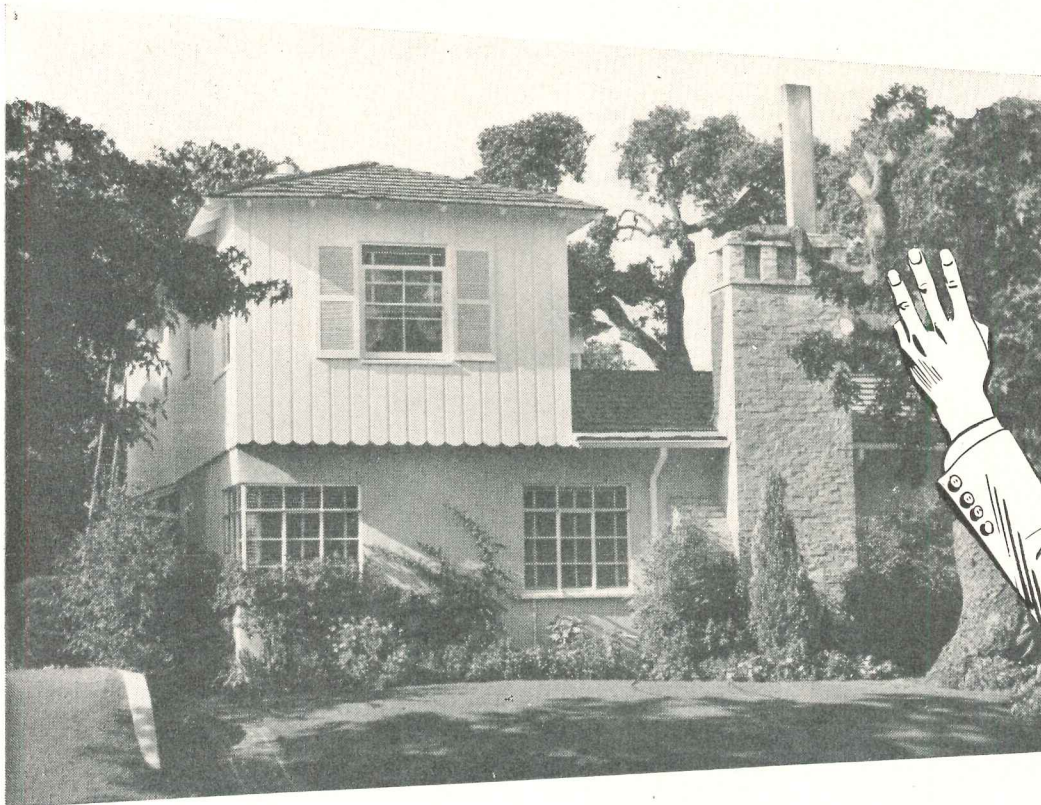

## This design idea impresses clients 3 ways

**Beauty and lower cost achieved with modern, reinforced concrete stucco. Durability insured with the Keystone System of Stucco Application.**

Yes, the house pictured above is designed and built with modern, reinforced concrete stucco.

Notice the fresh, distinctive beauty in stucco—particularly when combined with other siding materials. And, consider the many uses of this flexible design material—with color and texture as your clients desire.

Check stucco's lower cost in your own locality by comparing the cost of portland cement with equivalent materials.

Then, investigate the Keystone System of Stucco Application to see how it insures stucco's durability and adaptability to any climate.

*For complete stucco specifications and all the facts about the Keystone System of Stucco Application, write for informative booklet, "Specifications for Beautiful, Durable Stucco."*

**Keystone Steel & Wire Company**  
PEORIA 7, ILLINOIS

*Manufacturers of Keymesh Reinforcing, Welded Fabric, Tie Wire and Nails*

The KEYSTONE SYSTEM of Stucco Application—using Keymesh Reinforcing, furred out  $\frac{1}{4}$ " to  $\frac{3}{8}$ " from the felt backing—gives stucco strength right in the middle of the tension zone. Normal structural movement is counteracted by the rigidity and strength of Keymesh Reinforcing, to resist cracking and checking.

Stucco's durability has been proved on thousands of homes erected with Keymesh Reinforcing—in both hot and cold climates. Specify Keymesh Reinforcing for new home construction and overcoating— $1\frac{1}{2}$ " hexagon mesh, 17-gauge galvanized steel wire, or 1" hexagon mesh, 18-gauge galvanized steel wire.

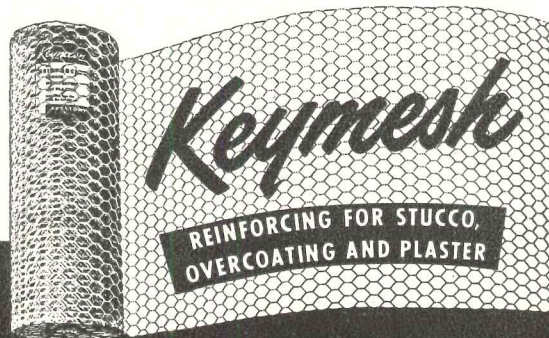
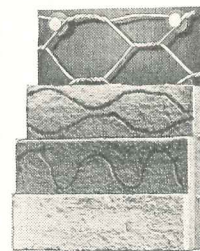

**DURABLE, LOW-COST STUCCO  
CALLS FOR KEYMESH**



## The Window with the MAGIC FLUE

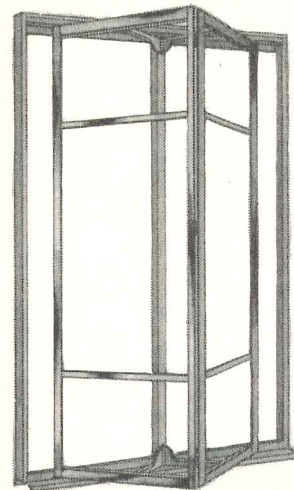

Sealuxe-Browne Folding-Type Windows; Sealuxe Double-Hung Windows; Sealuxe Casement Windows; Sealuxe Alumitex Fins, Spandrels, Canopies, etc.; Sealuxe Theatre Display Systems; Sealuxe Specialty Hardware.

Specify Sealuxe-Browne Windows with full confidence that they will bring the building owner substantial savings.

*Savings No. 1.* Both sides of glass cleaned from roomside; eliminates costly outside window washing.

*Savings No. 2.* 100% controllable draft-free ventilation; a major aid to any air-conditioning system.

*Savings No. 3.* Prefabricated of huge extruded aluminum sections; no maintenance; no painting.

*Savings No. 4.* Alumilite finish that will not tarnish.

*Savings No. 5.* Simplicity of design, precision manufacture and sturdiness assure trouble-free operation.

Our experienced designing and engineering staff is ready to work with you. For complete information about Sealuxe-Browne Windows refer to Sweets or write us.

**"Patio Suites" Addition  
Hotel Westward Ho  
Phoenix, Arizona**

*Architect*  
WALTER W. AHLISCHLAGER

*General Contractor*  
DEL E. WEBB CONSTRUCTION CO.

Mr. J. B. Mills, President, Hotel Westward Ho, wrote Mr. J. P. Travis, President, Universal Corporation, as follows:

"The additional rooms at the Hotel Westward Ho, Phoenix, Arizona, which have just been completed, have your Sealuxe-Browne Folding Windows and we find them to be very satisfactory. We have had many compliments from many guests, including contractors, and they are most complimentary of this window for hotel use. We consider it the best window available and we shall be glad for you to use our name as reference with hotel operators contemplating new construction."

*Universal*  
CORPORATION

6710 Denton Drive Dallas 9, Texas

District Offices: Los Angeles • Dayton • Des Moines • Houston

Qualified Sales Representatives in All Architectural Centers



One of a series of papers prepared by leading authorities on air conditioning. The opinions and methods presented are their own and are not necessarily endorsed by Kinetic Chemicals, Inc. Write Kinetic for free reprints of advertisements in this series.

# COMFORT AND EQUIPMENT COOLING IN TELEVISION

by C. A. Rackey, Manager, Audio and Video Engineering, National Broadcasting Company, Inc.



**C. A. Rackey** is in charge of design and installation of NBC studio plant facilities, both technical and mechanical, for sound and television broadcasting.

Most of the present NBC technical plants throughout the country, including Radio City, were engineered under his supervision.

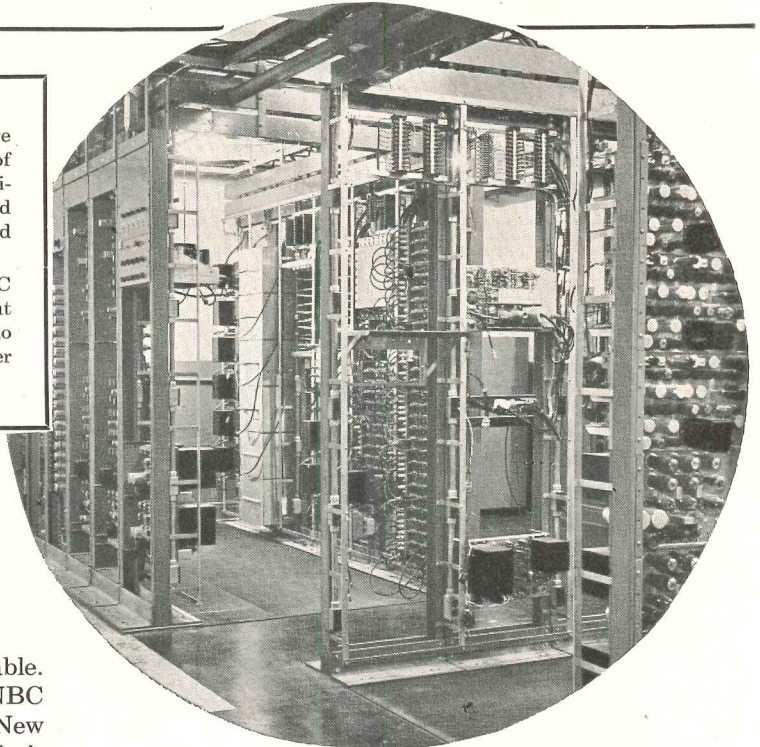

Heat-producing and radiating equipment is shown at the right in this television master control room at NBC, Hollywood. The synchronizing generators and video distribution amplifiers employ hundreds of vacuum tubes.

Radio broadcasters were among the earliest commercial users of air conditioning. The necessity for sound-proofing and acoustical treatment in sound studios produced insulated, windowless enclosures, making comfort cooling inevitable. The first major network headquarters, the NBC plant of eight studios at 711 5th Avenue in New York City included the finest installation of air conditioning equipment it was possible to obtain in 1927. This equipment is still in use!

The advent of television substantially increased the problems of cooling studios, since the Iconoscope, the original television camera pickup tube, required an average of 800 foot candles on a scene for proper operation. Within the past several years, however, Image Orthicons have replaced Iconoscopes for live talent pickups, permitting use of greatly reduced light intensities. Present Orthicons operate at incandescent light levels averaging 150 foot candles for general studio-type productions, but can furnish usable pictures, often required in operations outside the studio, on considerably less light. In the very near future camera pickup tubes of even greater sensitivity than present types will become available.

## TELEVISION STUDIOS

The principal heat load in a television studio is that resulting from the relatively high intensity lighting required to illuminate the scenery, properties and performers. It must be emphasized that

under actual television program production conditions light is often "poured" on—even wasted—rather generously, and may greatly exceed the theoretical levels related to actual pickup tube sensitivity that could be realized under laboratory or demonstration conditions. This factor must be considered from the standpoint of cooling safety factor in any well-designed television plant.

A substantial portion of the load is radiant heat which, in its effects on the human body, is somewhat difficult to handle. It requires an amount of moving cooled air on the skin while under the lights which may be quite uncomfortable otherwise. Since actors are as often off the set as on, it is necessary to compromise. It has been our experience that, based on a lighting load unit of 40 watts per square foot over the illuminated area, and assuming that only half of a studio is thus illuminated at any one time, about twelve air changes per hour and a winter return temperature of 72°

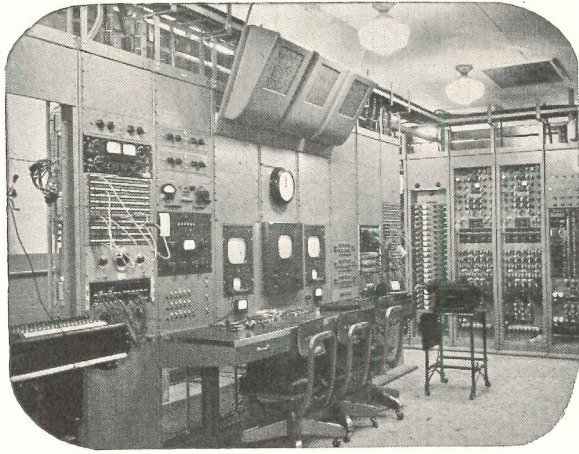

Corner of a television control equipment room, which includes distributing and isolation amplifiers, video switching relays and power supply units. Bulk of the heat-producing television equipment is located here.

will provide generally satisfactory results in a studio 30 x 50 x 18 or larger.

Heated air from the lights is collected in the upper portion of a studio, and therefore the supply ducts should project through this region into the level at which most of the light units are suspended. This is usually just above the sets. Since the air supply is thus relatively close to the personnel, good diffusion by use of proper outlets, and a sufficient number of them, is important. A multiplicity of supply outlets is required for another reason also; the fact that stage sets are usually scattered throughout the area of the average studio and may block off air from any particular outlet. A substantial number of properly distributed air return grilles is necessary for a similar reason and especially since sets are often backed up against a wall. Some of the return outlets may be located near the floor and some at levels above the scenery and some in the ceiling. Established positions for set-ups are helpful to the air conditioning designer. These are sometimes possible in smaller studios but rarely in the larger ones.

## LIGHTS

Both incandescent and fluorescent types of lighting are in present use, with a definite trend toward a greater admixture of fluorescent. The latter provides an increase in efficiency, but it is considered unsafe for the present to take too much advantage of this fact in sizing refrigeration. A considerable amount of incandescent lighting will continue in use owing to its greater susceptibility to optical control. In addition, more efficient lighting will be used in greater quantities, since it will simplify set-up problems and will permit use of smaller camera lens apertures, giving a greater depth of field for certain shots than is currently possible.

## CONTROL BOOTHS

The television cameras used in a studio are a minor portion of the entire complement of technical equipment required to produce a picture. Other equipment, as camera control and switching units, picture monitors, audio amplifiers, mixers and

transcription turntables, is usually located in a booth adjacent to the studio. Here the principal problem is reducing the effect of radiated and air-conducted heat, produced by this equipment, on the technical and production personnel required to work in its proximity. A secondary but quite important requirement is to conduct sufficient heat away from the apparatus to maintain it in a safe operating condition.

The average booth equipment heat load may be five kilowatts. Best practice is to introduce air for personnel comfort in a normal manner then pull it through the equipment, where it can be permitted to attain a return temperature of about 100° F. maximum. Additional air can be introduced within or in the vicinity of the equipment to arrive at the desired return temperature. Insulating and

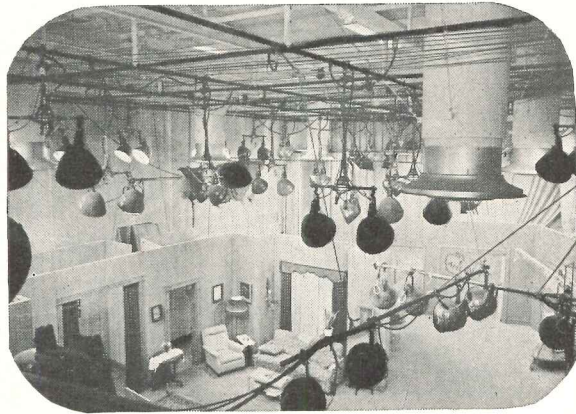

Typical NBC television studio set-up, showing air conditioning supply ducts.

reflecting barriers should be used, where possible, to reduce radiation in the direction of personnel.

A major problem regarding control booths is to have them large enough to provide a decent ceiling height and to avoid necessity for an excessive amount of air changes. Many present television studios are conversions of former sound broadcasting studios, and the associated control booths are generally small for television use.

\* \* \*

*In specifying air conditioning equipment for television studios . . . or for any type of structure . . . engineers and architects unhesitatingly specify equipment designed to utilize "Freon" safe refrigerants. Nontoxic, nonflammable, nonexplosive, "Freon" refrigerants are also noncorrosive, anhydrous and as chemically pure as scientific methods of manufacture can make them. They protect investment in the system by assuring its dependable, economical, trouble-free operation. Kinetic Chemicals, Inc., Tenth and Markets Sts., Wilmington 98, Del.*



# FREON *SAFE* REFRIGERANTS

*"Freon" is Kinetic's registered trade mark for its fluorinated hydrocarbon refrigerants and propellents.*

CRAM & FERGUSON CO., Boston ● Architects  
 BUERKEL & CO., Boston ● Heating Contractor  
 P. W. DONOGUE CO., Boston ● Plumbing Contractor

WATER HEATERS in the NEW ENGLAND MUTUAL LIFE INSURANCE CO., BUILDING, BOSTON

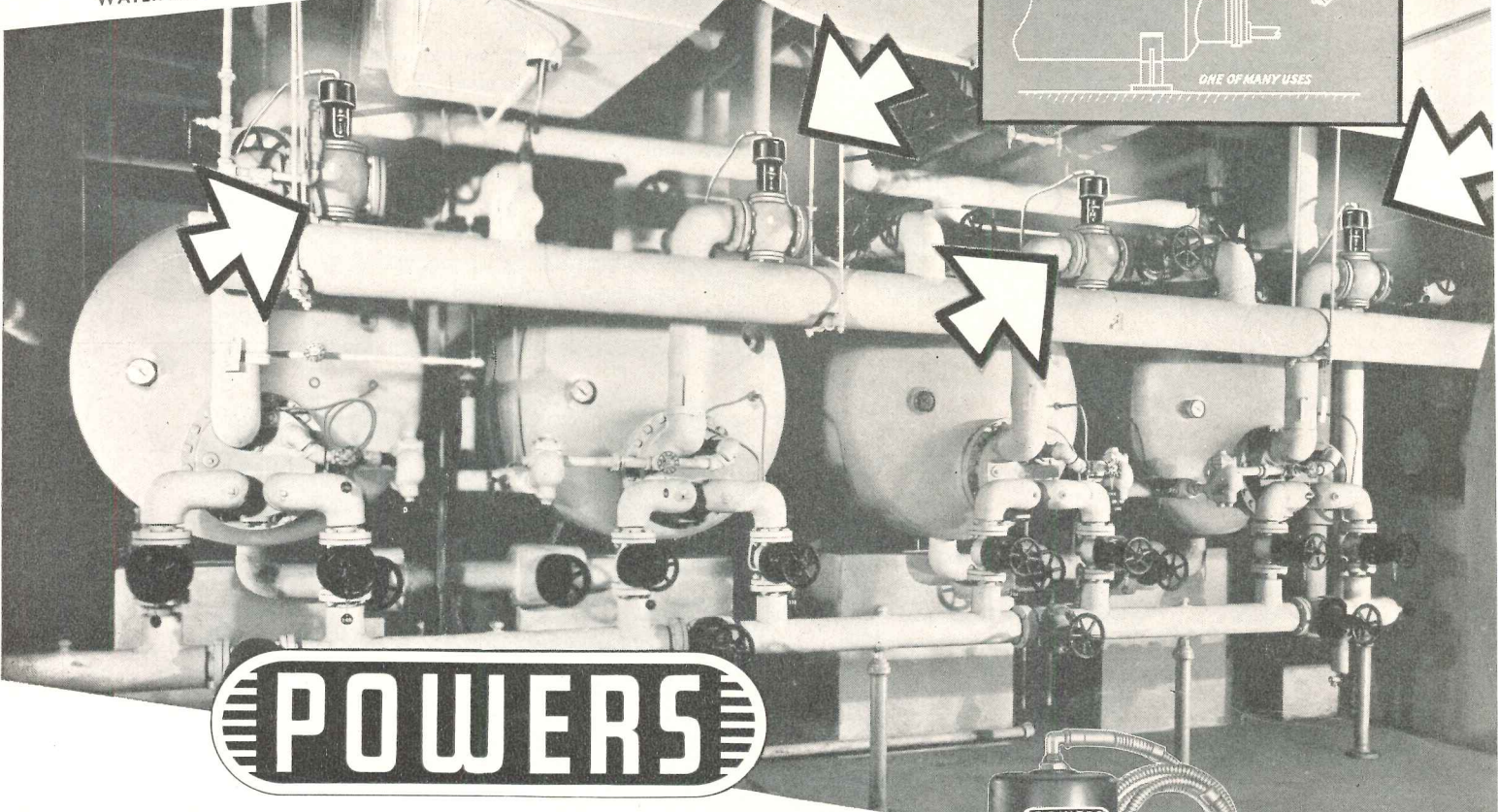
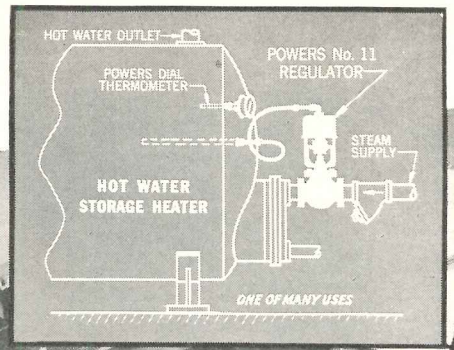

# POWERS

## TEMPERATURE CONTROL

helps pay bigger dividends to policyholders of  
 New England Mutual Life Insurance Co.

**Saves Fuel and Prevents OVER-heating**—Fuel savings alone often pay back the cost of Powers regulators on water heaters 3 to 6 times a year. They put an end to hot water complaints.

**Users Report 15 to 25 Years of Dependable Service**—Because of their simplicity of design and durable construction Powers regulators are famed for their year after year low cost, trouble free service.

**Complete Line of Controls**—Self-acting and water operated regulators and air-operated indicating and recording controllers for:

- INSTANTANEOUS HEATERS ● FUEL and CRUDE OIL HEATERS
- TWO-TEMPERATURE SERVICE HOT WATER SYSTEMS
- JACKET WATER IN COMPRESSORS, DIESEL and GAS ENGINES
- INDUSTRIAL PROCESSES

**When You Need Help** on your problems of temperature and humidity control take advantage of our 58 years of experience in this field . . . Contact our nearest office.

CHICAGO 14, ILL., 2720 Greenview Ave. ● NEW YORK 17, N. Y., 231 East 46th Street  
 LOS ANGELES 5, CAL., 1808 West Eighth Street ● TORONTO, ONT., 195 Spadina Ave.

## THE POWERS REGULATOR CO.

OFFICES IN 50 CITIES ● SEE YOUR PHONE BOOK

*Over 55 Years of Temperature and Humidity Control*

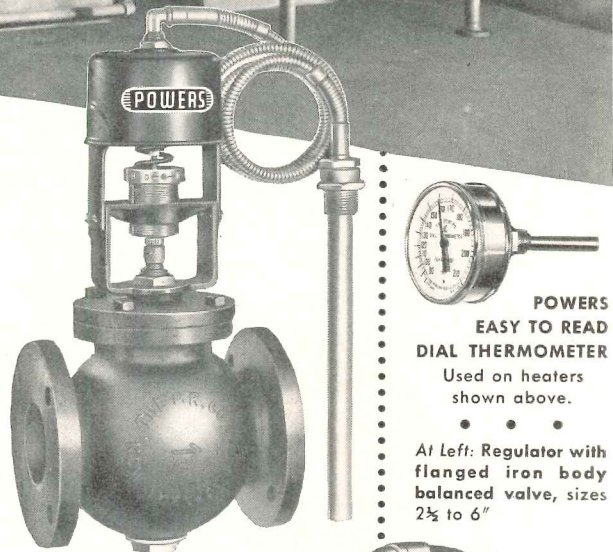

**POWERS EASY TO READ DIAL THERMOMETER**  
 Used on heaters shown above.

At Left: Regulator with flanged iron body balanced valve, sizes 2½ to 6"

### No. 11 REGULATORS Self-Acting

Right: Bronze body balanced valve with union connections, sizes ½ to 2". Single seal valves with union connections ¾ to 1½". 3-Way valves for mixing hot and coldwater. Indicating Regulators with dial thermometer. Stem Lubricator and Safety-Over-heat protection standard on sizes to 2" incl.

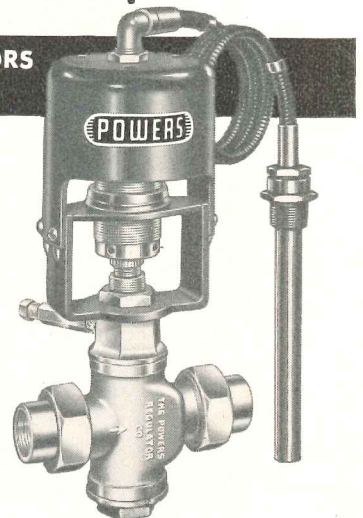

Phone or Write  
 nearest Office for  
 Bulletin 329

an entirely new concept of elevating

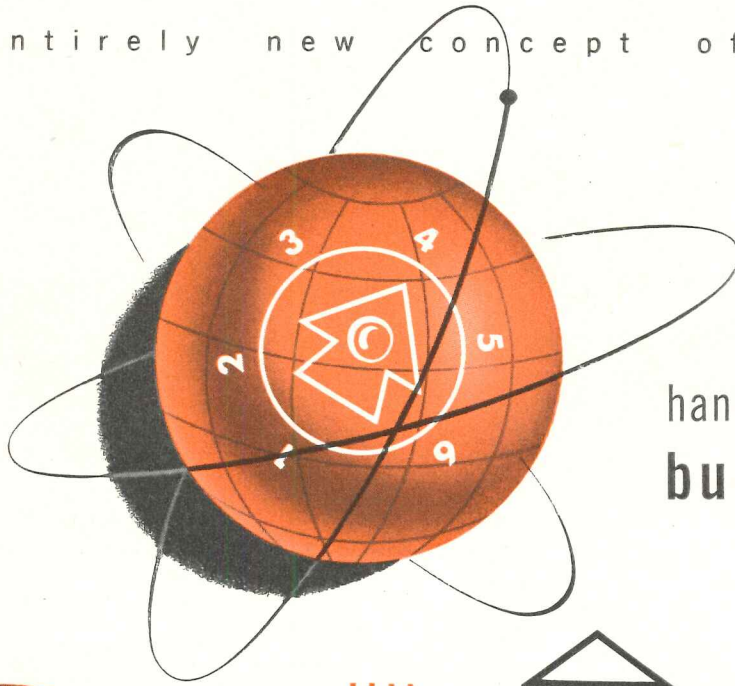

handles suddenly  
**bunched traffic**  
automatically

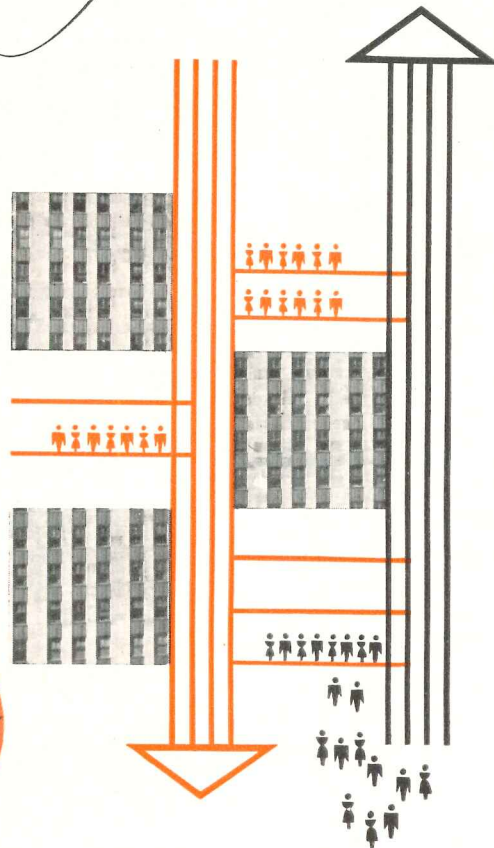
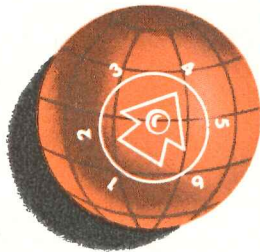
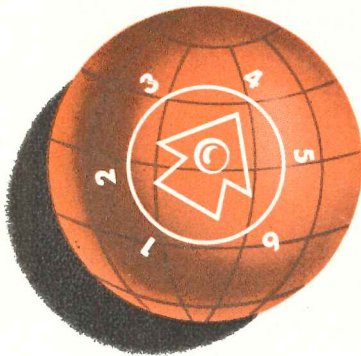

It no longer matters how people move around in an office building. They can come into the lobby in droves; go down for a snack in bunches; or come out of sales meetings en masse—anytime! They can still have good elevator service. For each of the 6 AUTOTRONIC Traffic-Timed ELEVATORING programs has been engineered to handle all traffic surges within its pattern—automatically! And it doesn't matter how sharp or heavy the surges are, the AUTOTRONIC system will take care of them and re-balance itself without any assistance from the starter.

Booklet B-721-F explains how OTIS AUTOTRONIC Traffic-Timed ELEVATORING matches service to all 6 of today's traffic patterns... provides automatic operation and supervision for NEW or EXISTING groups of elevators... and improves service in office buildings, hotels, hospitals and department stores.

Address: Otis Elevator Company,  
260 11th Avenue, New York 1, N. Y.

Otis...first with Electronic Signal Control...again first with Traffic-Timed Elevating



**OTIS AUTOTRONIC ELEVATORING**

*Traffic  
Timed*



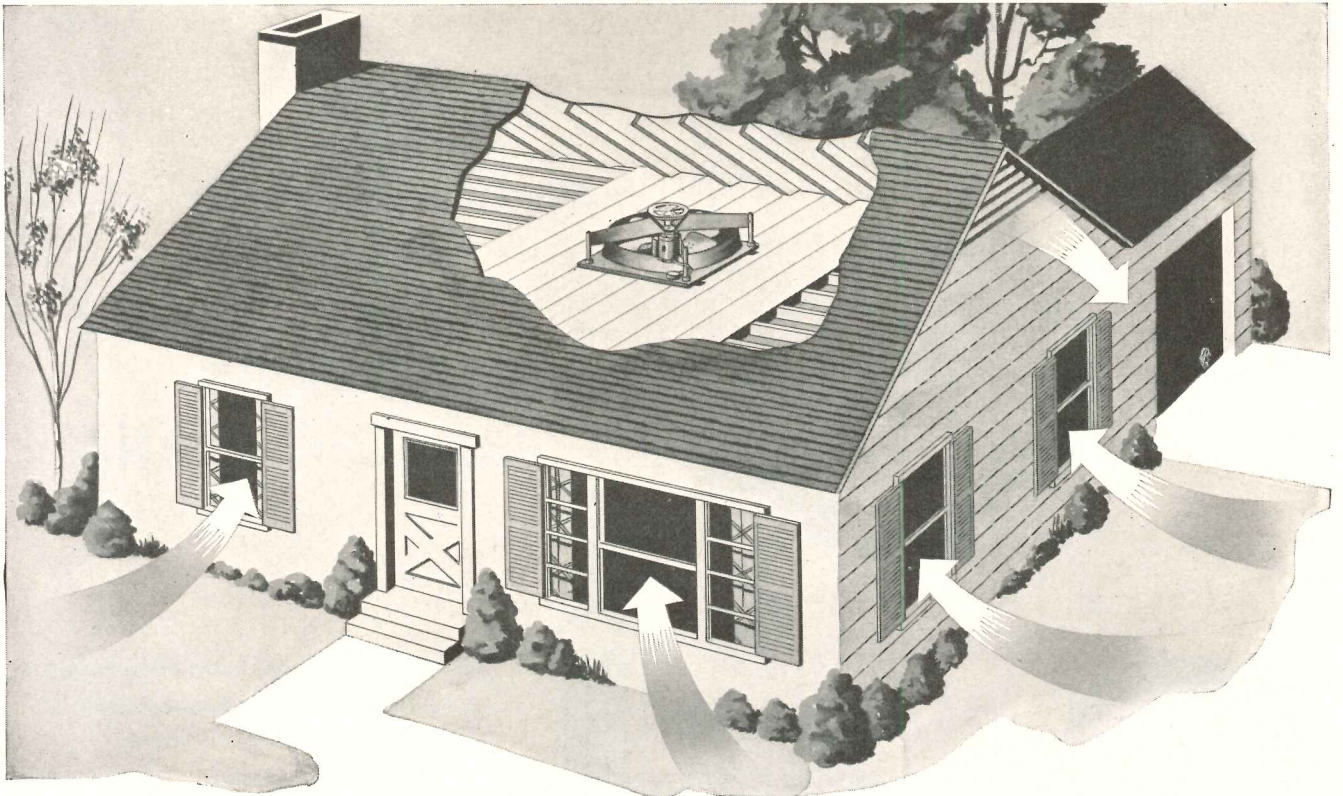

**IT COSTS VERY LITTLE TO**

*Cool the entire house*

**with a Hunter Package Attic Fan**



**Pull on chain opens shutter and starts fan**

When you specify the Hunter Package Fan, you provide cool summer comfort for the least cost. Attractive appearance and easy, trouble-free operation will please any home owner.

**Low-Cost Installation:** The Package Fan requires only a simple ceiling opening, plus attic exhaust. No suction-box needed. Integral ceiling shutter, trim and switch reduce installation costs to a minimum.

**Compact Design:** 38" x 40", overall. Extends only 17" above attic floor. Ideal for low attics.

**Performance:** Certified air delivery, with shutter: 9500 CFM. Tested by independent laboratory according to Standard Test Code of ASH&VE and PFMA. Quiet, dependable operation assured by Hunter-quality construction. Fan guaranteed for 5 years; motor, 1 year. See Sweet's Catalog. Or mail coupon for Data File.

**HUNTER FAN & VENTILATING CO., INC.**  
 396 South Front Street,  
 Memphis, Tennessee  
 Exclusive Fan Makers Since 1886

Hunter Fan & Ventilating Co., Inc.  
 396 South Front Street, Memphis, Tennessee

Send complete architectural data on the New Hunter Package Fan to:

Name.....  
 Firm.....  
 Address.....  
 City.....State.....

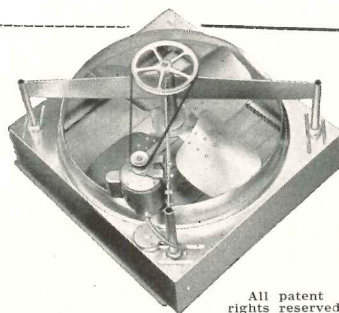

All patent rights reserved





# NEPCODUCT

## THE STEEL UNDERFLOOR ELECTRICAL RACEWAY SYSTEM

FOR NEW CONSTRUCTION AND MODERNIZATION

*Fits ANY TYPE of floor construction*

### PROVIDES CONVENIENCE OUTLETS AT THE FLOOR SURFACE

New junction box permits installing NEPCODUCT in the upper 2½" of concrete slab or above steel deck construction.

- A complete and independent system to meet electrical designs of engineers and for installation by electrical tradesmen.
- Brings outlets—already threaded—to the concrete floor surface.
- Eliminates cutting the permanent structure and boring through raceway to establish service connections.
- Reduces cost of electrical extensions and maintenance through easy accessibility to services in junction boxes and outlets.
- Ample outlets and circuit capacity for telephone, communications, light and power.

**National Electric PRODUCTS CORPORATION**

1327 CHAMBER OF COMMERCE BUILDING, PITTSBURGH 19, PA.

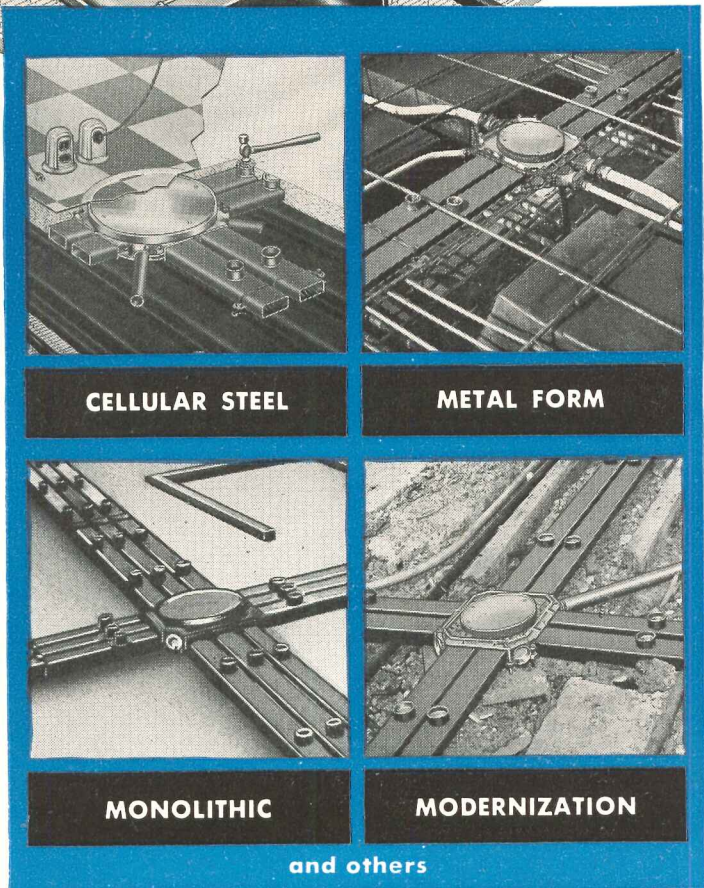
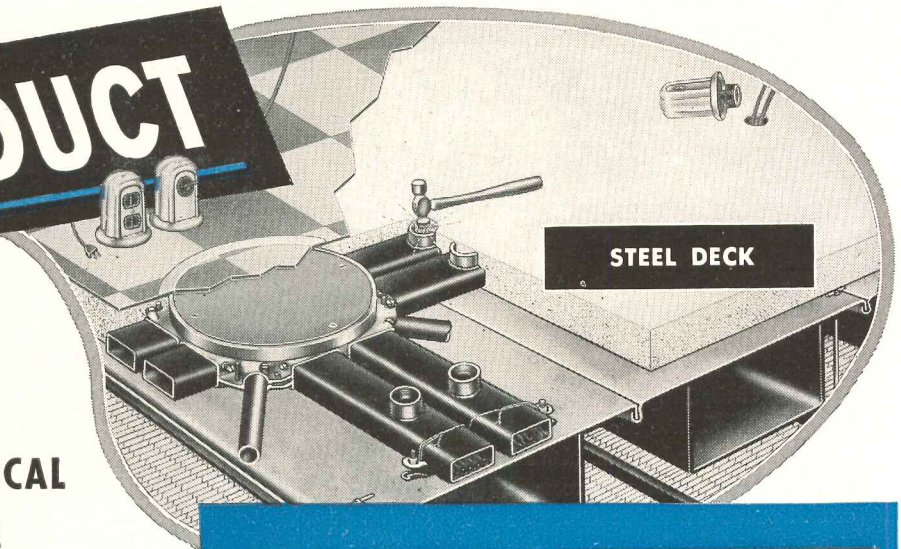

*Steel for permanence  
Grounded for Safety*

Let us send you complete service and installation data on NEPCODUCT Under-floor Wiring Systems and Service Fittings.



Close-up of the Empire Savings facade shows effective use of bronze against background of black Italian marble. Heavy outer doors are made of cast panels framed in Anaconda Extruded Bronze. Grille above is fabricated from red brass sheet, rod and tubes. The street windows, presenting dioramas of the Old West, are also framed in Anaconda Bronze.

Private office partitions at Empire Savings are formed of glass panels supported by Architectural Bronze frames.

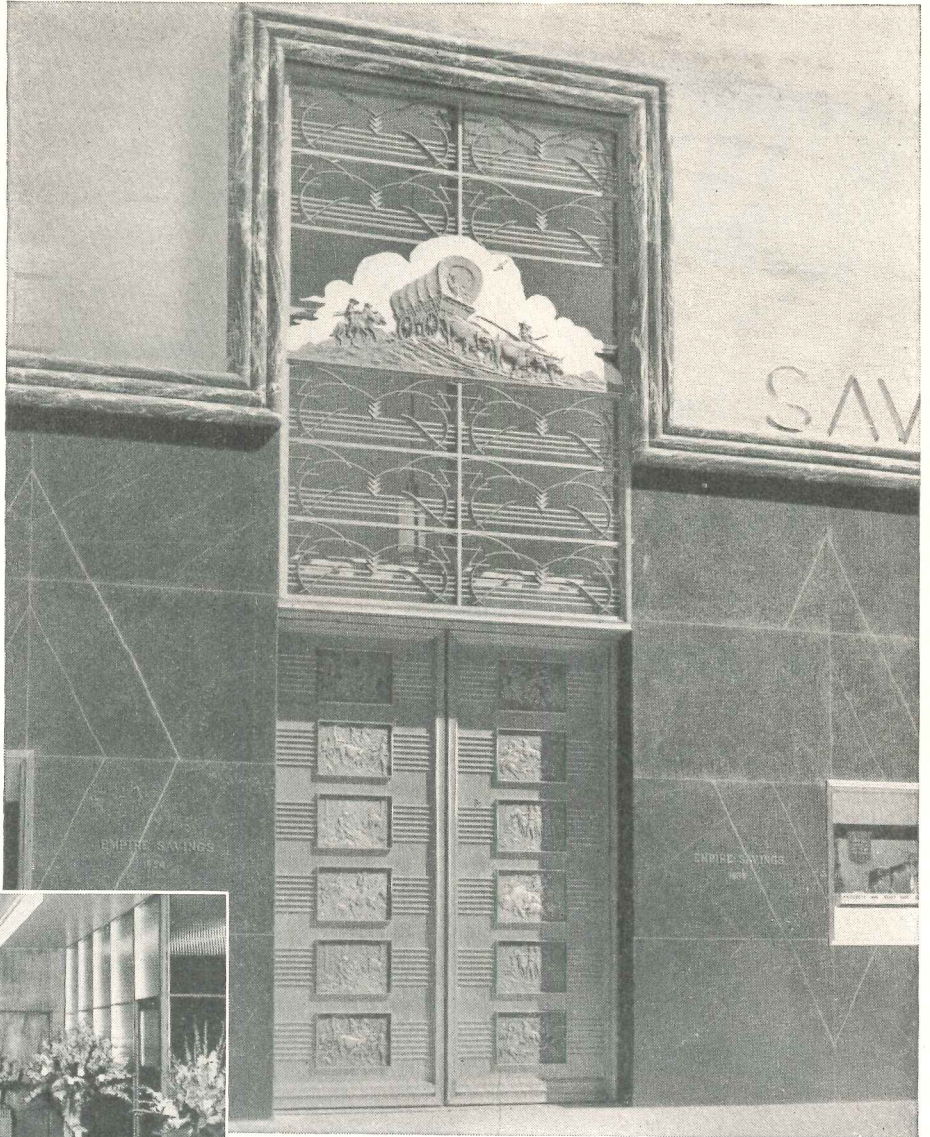

PHOTOS BY SOUNDSTILLS, DENVER.



## THE OLD WEST GOES MODERN ... IN TIMELESS Bronze

SCENES OF THE WEST in its wild and wooly days provide the motif for the ultra modern decor of Denver's new Empire Savings Building.

Architect for the new home of the Empire Savings Building and Loan Association is Roger J. Musick, of Denver. Architectural bronze work was fabricated by the William G. Zimmerman Ornamental Iron Works, also of Denver.

Except for the bronze castings and other materials for color contrast, Mr. Zimmerman employed Anaconda Alloys exclusively — extruded architectural bronze shapes, red brass rod, sheet and tube.

In adding this work to his long list of artistic achievements, Mr. Zimmerman reaffirms his confidence in the uniformity of Anaconda Architectural Bronze in color, texture and physical properties.

4901

  
**Anaconda**  
**ARCHITECTURAL BRONZE**  
**THE AMERICAN BRASS COMPANY**  
 General Offices: Waterbury 88, Connecticut  
 Subsidiary of Anaconda Copper Mining Company  
 In Canada: ANACONDA AMERICAN BRASS LTD.  
 New Toronto, Ont.



**FIRE SAFE!**

## PUMICE CONCRETE will not explode or spall under severe test conditions

Independent tests, extending over a period of years, have conclusively proved the Fire-Safe properties of light-weight concrete made with pumice aggregate.

In 1945, full size reinforced concrete and reinforced pumice concrete dwellings were filled with gasoline soaked sand and ignited. The conventional concrete exploded and spalled, exposing the reinforcing steel which was also damaged by the intense heat. The pumice concrete dwelling remained intact showing only a black discoloration.

In a succeeding test, four streams of water were played on the conflagration at its maximum intensity. Subsequent inspections disclosed **NO STRUCTURAL DAMAGE** to the pumice concrete. Tests at the Navy Ordnance Test Station, Inyokern, California, have resulted in pumice being specified for several government housing projects.

Pumice concrete has a resistance to fire at least twice that of hard rock concrete and many structural engineers consider it the finest fire resistant construction material on the market.

Underwriters' Laboratory has found that an 8-inch standard pumice masonry wall will achieve a 4-hour rating when subjected to standard test.



The workman is holding a slab of pumice concrete is his bare hand while heating the face of the slab to fusion with a gas torch.

Perhaps the most valuable of all characteristics of Pumice Aggregate used in making light-weight pumice concrete is its thermal insulation. A dramatic demonstration is shown in the photograph below.

### INSULATION OF CONCRETE

Comparison Between Pumice Concrete and Ordinary Concrete

- • • Pumice Concrete "U" Factor based on a "K" factor of 1.85. Ref. Pittsburgh Testing Laboratories No. 24183.2
- — — Ordinary Concrete "U" Factor based on a "K" factor of 12. ASHVE Handbook.

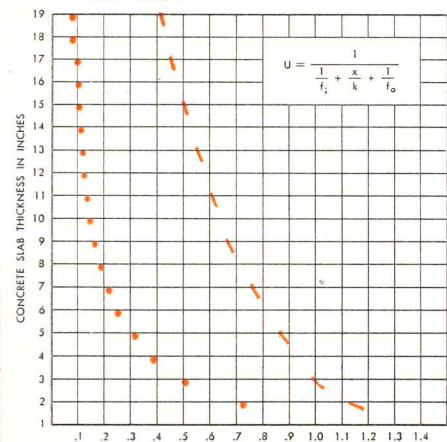

$$U = \frac{1}{\frac{1}{f_1} + \frac{x}{k} + \frac{1}{f_2}}$$

"U" Factor — B.T.U./Hour/Sq. Ft./Degree F. Difference Existing between air temperatures on two sides of wall.

GENERAL PUMICE CORPORATION  
P.O. Box 1445  
Santa Fe, New Mexico



**MEMBERS**



DESERT MATERIALS CORPORATION  
5771 Wilshire Blvd.  
Los Angeles 36, Calif.



PUMICE AGGREGATE SALES CORPORATION  
121 South Yale  
Albuquerque, N. M.



## PUMICE PRODUCERS ASSOCIATION

715 FIRST NATIONAL BANK BLDG. • ALBUQUERQUE, NEW MEXICO

UNIFORM GRADED PUMICE is a name applied only to pumice aggregate produced by members of the Pumice Producers Association. Write your nearest producer for technical data. Additional information is in your 1949 Sweet's Architectural (4E/5) and Engineering (4A/8) files.

THE EMBLEM of the Pumice Producers Association stands for Quality Pumice suitable for aggregate in the production of lightweight concrete for structural purposes. It is for your protection; only members of the Association and their franchised manufacturers are permitted to display it.

LIGHT WEIGHT • SOUND PROOF • INSULATING

**uniform graded pumice aggregate**

FIRE PROOF • NAILABLE • SAWABLE

# HONEYWELL COMFORT

begins  
with the  
*Blueprint*

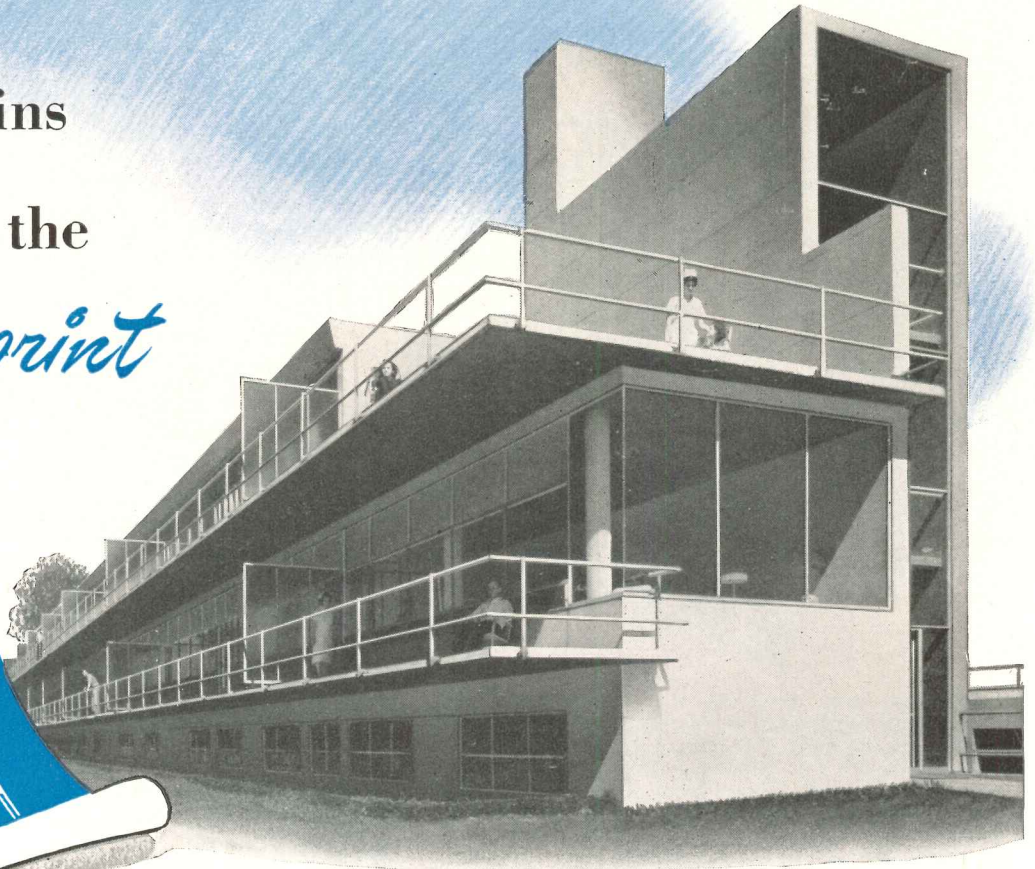

Lake County Tuberculosis Sanitarium, Waukegan, Illinois  
Architect: William L. Pereira

## ...IN THE MODERN HOSPITAL

To insure the comfort and speedier convalescence of their patients, modern hospitals are demanding the newest developments in heating, ventilating and air conditioning equipment. Individual thermostat control in every room and every ward is a "must".

Whether you are interested in hospitals or schools, hotels or apartments, stores or factories, the time to specify the proper automatic controls is when the building is in the blueprint stage. And

remember, no heating or air conditioning system can be better than the controls that regulate it.

For 64 years, Minneapolis-Honeywell has pioneered in the development of automatic controls for residential, commercial and industrial applications. Experienced Honeywell engineers are available for consultation on any automatic control problem. Just contact the Honeywell branch office in or near your city, or write to Minneapolis-Honeywell, Minneapolis 8, Minnesota.

*For specific information on Honeywell controls and control systems for hospitals, mail the coupon for booklet "Plan Your Hospital's Atmosphere"—just off the press.*

MINNEAPOLIS  
**Honeywell**  
CONTROL SYSTEMS

MINNEAPOLIS-HONEYWELL REGULATOR COMPANY  
2600 Fourth Avenue South • Minneapolis 8, Minnesota

Please send free booklet "Plan Your Hospital's Atmosphere"

Name \_\_\_\_\_

Company Name \_\_\_\_\_

Address \_\_\_\_\_

City \_\_\_\_\_ Zone \_\_\_\_\_ State \_\_\_\_\_

73 BRANCHES FROM COAST TO COAST WITH SUBSIDIARY COMPANIES IN: TORONTO • LONDON • STOCKHOLM • AMSTERDAM • BRUSSELS • ZURICH • MEXICO CITY

## DESIGNERS EXTRAORDINARY

ONE would have to search like an FBI agent to find an architect who would be a mite hesitant about suggesting improvements in the design of most anything under the sun, from automobiles, armchairs and advertisements to velocipedes, yo-yos and zithers. And we'll bet they could provide better designs for them, too! Then why don't they? The answer is they do (see pages 102-115). But even these designs can and will be vastly improved as time goes on.

The same design ability, approach and technique that goes into the design of buildings is essential to better design of manufactured products — and some of the more farsighted producers have realized this and have added architecturally trained men to their staffs or have commissioned them to produce advanced designs. Also most of the industrial designers and stylists that specialize in designing for industry employ men and women having architectural background and experience.

Only the addition of two other factors to the present knowledge and skills of the architect seems necessary to success in the broad field of designing useful objects. These are, first, salesmanship, and second, knowledge of special materials and manufacturing processes and techniques. But salesmanship has not often been the forte of the designer himself. Salesmanship seems to be a flare for dramatic showmanship, plus personality, plus the ability to convince and persuade — with perhaps, or occasionally, a pinch or two of impressive and mystifying mumbo-jumbo. Salesmanship may be more difficult to acquire than the second factor, for unless it comes naturally and enjoyable to the designer it might better be delegated to a partner in the enterprise with a bent in this direction.

The second — knowledge of manufacturer's materials and techniques, is "duck-soup" for the architect, for his mind is trained to observe, analyze and discriminate. And this established process of his, coupled with his creative imagination, almost inevitably suggests new and better forms for the functioning of the product and for simplification of the manufacturing processes involved. We can quote chapter and verse and even picture to prove that statement. Not only have architect-designed products both functioned better and looked better, but they have been more economical to produce and maintain. What more could a manufacturer ask?

But the architect must ask himself whether the time and effort involved in making the necessary contacts with manufacturers will prove worthwhile to him, or whether, in his case, it might better be employed in cultivating his own specialized field of planning and building. We believe that more and more architects will design *both* the buildings and the things that go into them — furniture, fixtures, fabrics and all the rest — not only the custom-made, but the mass-produced. For architects *are* designers extraordinary!

*Kenneth K. Stowell*

EDITOR



## LAMONT LIBRARY, HARVARD UNIVERSITY

*Coolidge, Shepley, Bulfinch & Abbott, Architects and Engineers*

TO THOSE planning the Lamont Library, placing a building of organic architecture into Harvard Yard was not the primary problem, but to those less concerned with functioning it did seem the major consideration. Announcement that the Library was to be built in the Yard evoked a great volume of voluntary opinions, some for colonial architecture, some equally positive for modern.

Thomas W. Lamont, whose gift made the building possible, expressed the hope that it would "adhere as much as possible to the general spirit of the architecture of the Yard," which obviously is quite different from a simple request for colonial styling. In a letter to him Mr. Shepley made this interesting observation:

"Actually that part of the Yard where the Library is to be contains a very varied assortment of buildings of different types. Widener, Emerson and Robinson are Classic, Sever is Richardson Romanesque, the Union is English, the President's House, Houghton and Wiglesworth are modern Colonial. Many of these are distinguished examples of the style in vogue at the time, and thus make an interesting historical record. Most of

them were carefully designed to fit into the general spirit of the Yard. The Library is being studied with great care in this respect . . ."

The end of this little story comes in a memorandum from the librarian, Keyes D. Metcalf, to Mr. Shepley: "I had an opportunity to talk with Mr. Lamont, Sr. yesterday, and he asked me to report to you that he had seen the model and the plans and that he likes them . . ."

Mr. Shepley's own comments on the building warrant exact quotation: "The architectural treatment is modern, but the exterior has been carefully studied in proportions, fenestration, and materials to make it fit in comfortably and naturally with its traditional surroundings. Exaggerated modern features and affectations have been avoided and the treatment restricted to a simple and direct expression of the interior arrangement and philosophy, with special emphasis in certain appropriate cases."

He has illuminated this summary with many specific details, but these are best understood in the light of what the planners of the Library *did* feel was their pri-

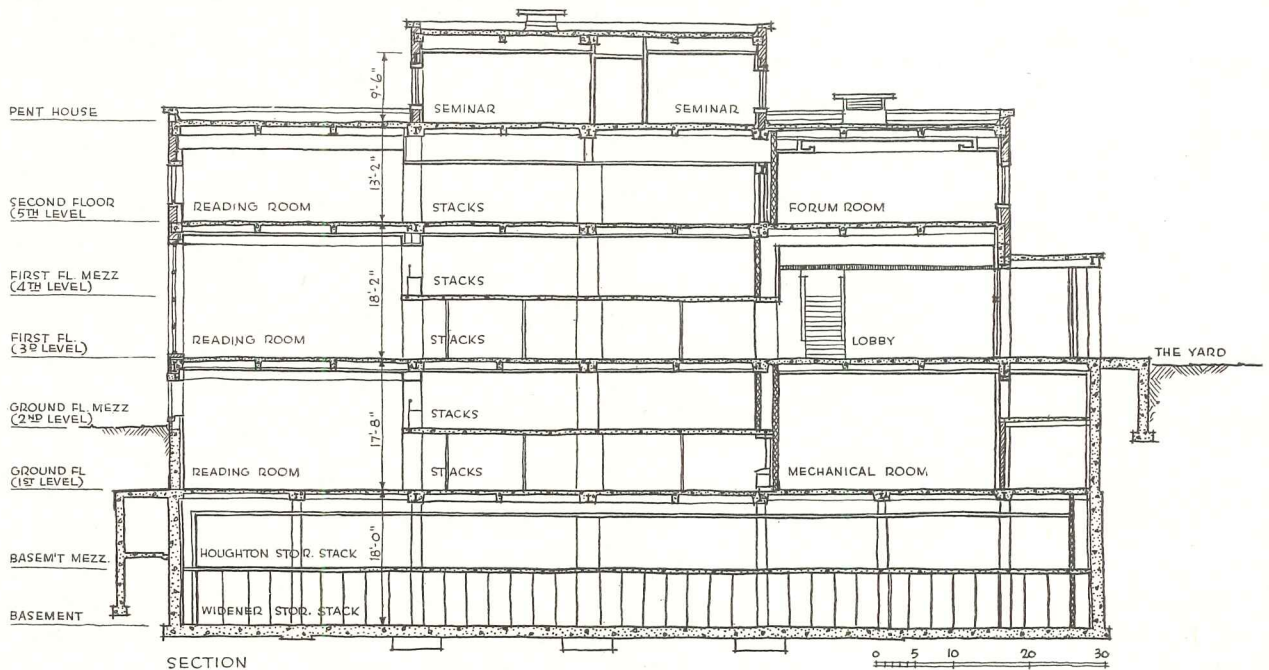
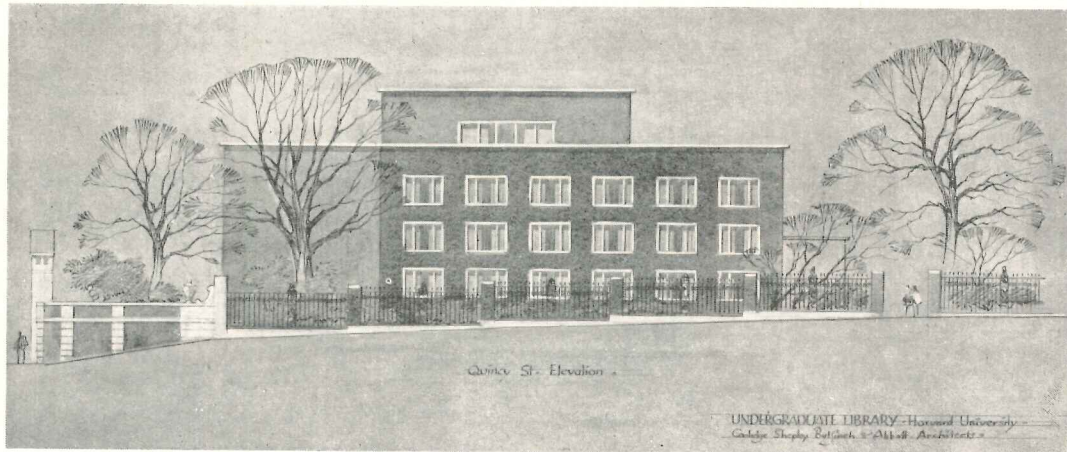

mary concern. Shepley gives the basic program thus:

"The philosophy on which the functioning of the Library was based required, first, that it be conveniently located and inviting of access. It should be on one of the main undergraduate traffic routes, and there should be no flights of steps to climb to the entrance or monumental vestibules or foyers to traverse before coming to the books. Second, once within the Library, the student should find the entire book collection as accessible as possible. The arrangement devised by the Librarian to accomplish these requirements called for long reading rooms on three floors on one side of the building paralleled for their entire length by open stack areas down the center. Specialized reading rooms, such as those for reference, browsing, and the modern poetry

collection, were to be on the opposite side of the stack area. As a result, students would pass through the stacks in going to the reading rooms or in passing from one reading area to another."

This general concept of the building was decided even before consideration of a site. Four sites were then measured against the building requirements, and the architects made a preliminary sketch for each of them. One site was simply too small; two others were adequate but not so fortunately located as the one finally selected, on the Yard at the corner of Quincy Street and Massachusetts Avenue. This one offered difficulties of contour and was not spacious, but did have the advantage of good relationship to associated buildings.

The difficulty of the size of the site was solved by

### THIRD LEVEL

Nothing got quite so much study as lighting. This particular installation, in the lobby, was designed to simulate the daylight just beyond the wide glass entrance doors. Thus lighting becomes a part of the invitation to the student extended by the open aspect of entrance and doors, coupled with a lack of steps or monumental vestibules to clothe the search for knowledge with cold austerity



Gottschö-Schleisner Photos

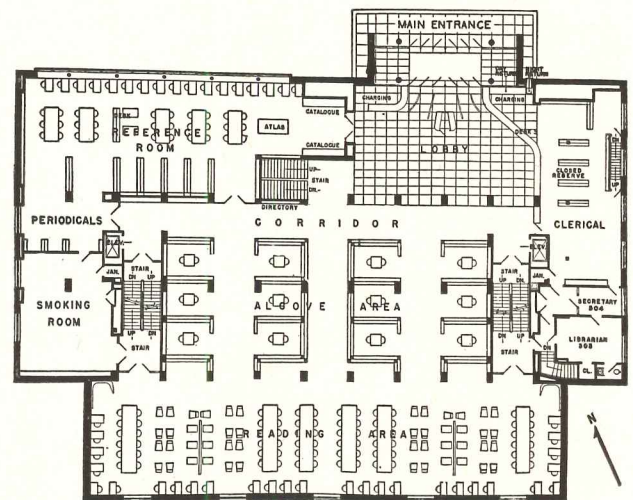

THIRD LEVEL PLAN (First Floor)

sinking one of the three main reading room levels below ground level, and by use of further basement space for large stack areas, these being connected to other library buildings. This device makes it appear as a two-story building from the Yard; also it limits the stair climbing to one flight up or down from the Yard entrance.

The large reading areas, coupled with the stack height requirements, were factors of considerable importance in fixing the design of the building. Now for Mr. Shepley's more detailed tracing of these architectural factors:

"Emphasis of interior features in exterior treatment may be seen in the projection of the main entrance motive beyond the face of the north front, increasing the

importance of the entrance and giving a valuable accent to an otherwise long unbroken façade. This entrance is very wide, almost the width of the lobby inside, and consists of six glass doors in a glass wall, flanked by limestone buttresses carrying a thin roof slab. The glass wall is recessed several feet from the buttresses and roof to give a sense of shelter. The wide glass entrance tends to lessen the barrier between exterior and interior; and to enhance this effect the lobby lighting has been made to simulate daylight. Furthermore, the interior arrangement is such that from without one may look through the lobby into the stacks, and beyond into the reading room on the farther side of the building.

"Next to the main entrance is the Reference Room





### THIRD LEVEL

Stacks on main reading levels are arranged in alcoves, each with a small table and chairs for students who must quickly consult a number of references to locate their material. Reference room, third level, below, has north light, can afford a great unshaded window running full length



Gottscho-Schleisner Photos

with its great north window overlooking the Yard and offering to all those passing a clear view into the Library. This window, occupying practically the whole side of the room, can afford to be spacious as it never receives any sun, while all the other windows on the main floor have to be shaded on sunny days.

"The main floor reading room on the south side is emphasized on the exterior by tall windows extending from floor to ceiling, spaced twice as far apart as the windows of other rooms. This gives an effect of dignity that relates well in scale with the Union, and particularly well with the Bacon-Roosevelt Gate.

"One important feature of the exterior is the free use of large unbroken wall surfaces. This is made possible by the fact that it is preferable to light the reading areas from one side only. The introduction of these wall areas at the corners of the building has the effect of breaking up the apparent bulk of the building by interrupting the continuity of window treatment. This interruption has the additional advantage of permitting each elevation to be treated appropriately and honestly in itself without the necessity of reconciling it too closely with its neighbors. The result has been an exterior with more interest and vitality than would otherwise have been

## FIRST AND SECOND LEVELS

The so-called First Level is the first of three main reading area levels, and is virtually a basement story, because of site problems, as Mr. Shepley has explained in the text. Air conditioning, lighting and ventilation are depended upon to make this just as comfortable and pleasant as upper areas. The Second Level is a mezzanine of the first level, stacks determining ceiling heights

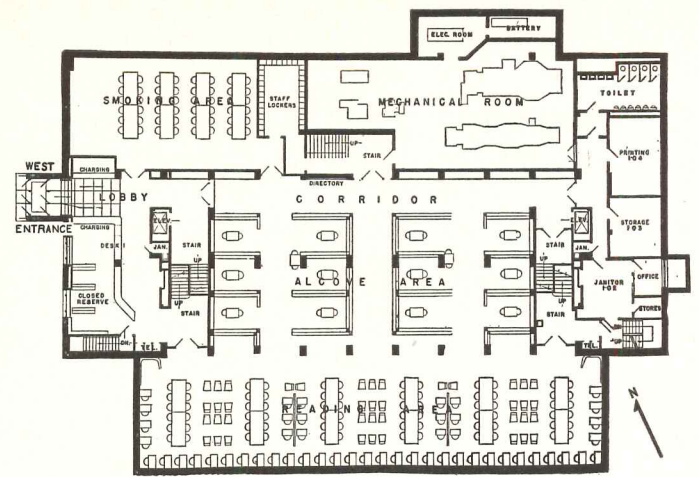

FIRST LEVEL PLAN





**SECOND LEVEL**

Photograph above shows typing cubicles in the smoking room, second level. Smoking room lighting shown is typical of that in eight-foot ceiling areas

possible." Special rooms have contributed much to the comfort and utility of Lamont Library (the three photographs across the two following pages show the Woodberry Poetry Room, with furnishings by Alvar Aalto). There have been many questions such as: should smoking be permitted, or talking, or typing? How much for comfort, for avoiding monotony? What special activities are within the library province? A great many such questions were settled quite nicely by providing a

**SECOND LEVEL PLAN (Fourth Level Similar)**

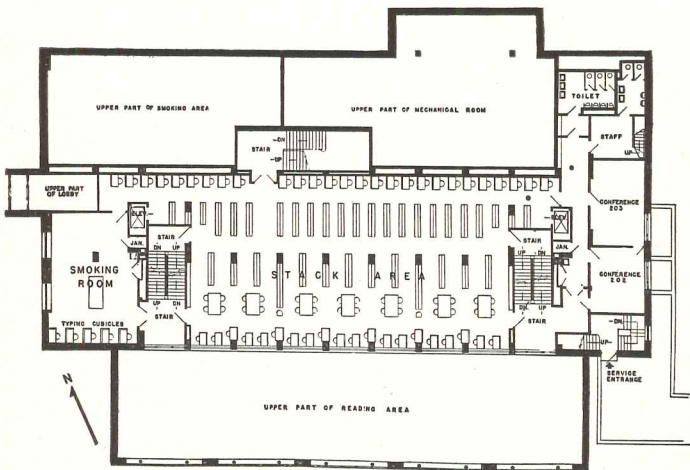

**FIFTH LEVEL PLAN**

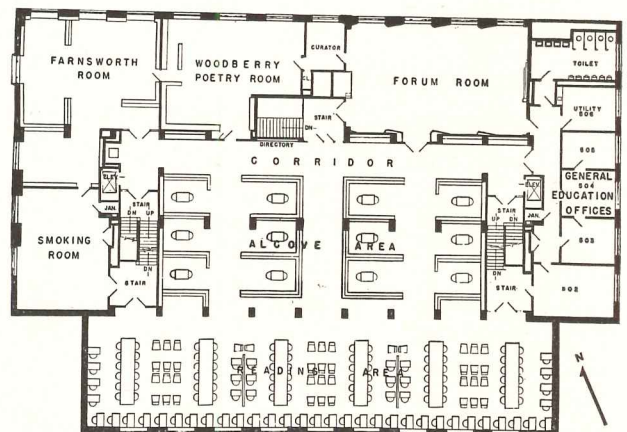



### FIFTH LEVEL

*Furniture throughout is of special design worked out by the architects in cooperation with the librarian: simple and as light as is consistent with comfort and sturdiness. It is light in color also, to keep brightness contrasts low. Indeed all color schemes were chosen for this main purpose. Easy chairs are in leather, tan, red or green. Bookcases are finished in enamel of medium value—old gold on ground floor, dull red for first floor, gray blue for the second. Floors are of cork in medium brown. Furniture for the first floor, by the way, is of special design by Alvar Aalto, manufactured in Sweden and assembled in this country*

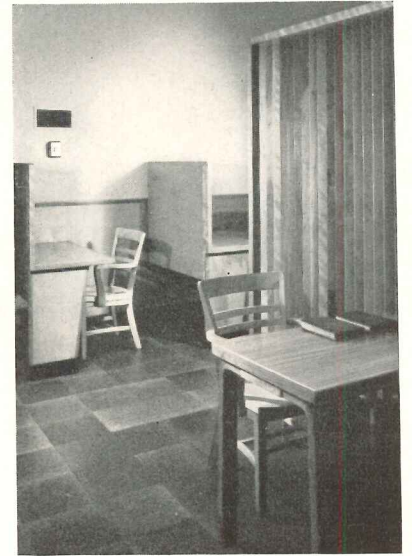

Gottcho-Schleisner Photos





Above, the Woodberry Poetry Room has furniture and equipment by Alvar Aalto

The Forum Room, on the fifth level

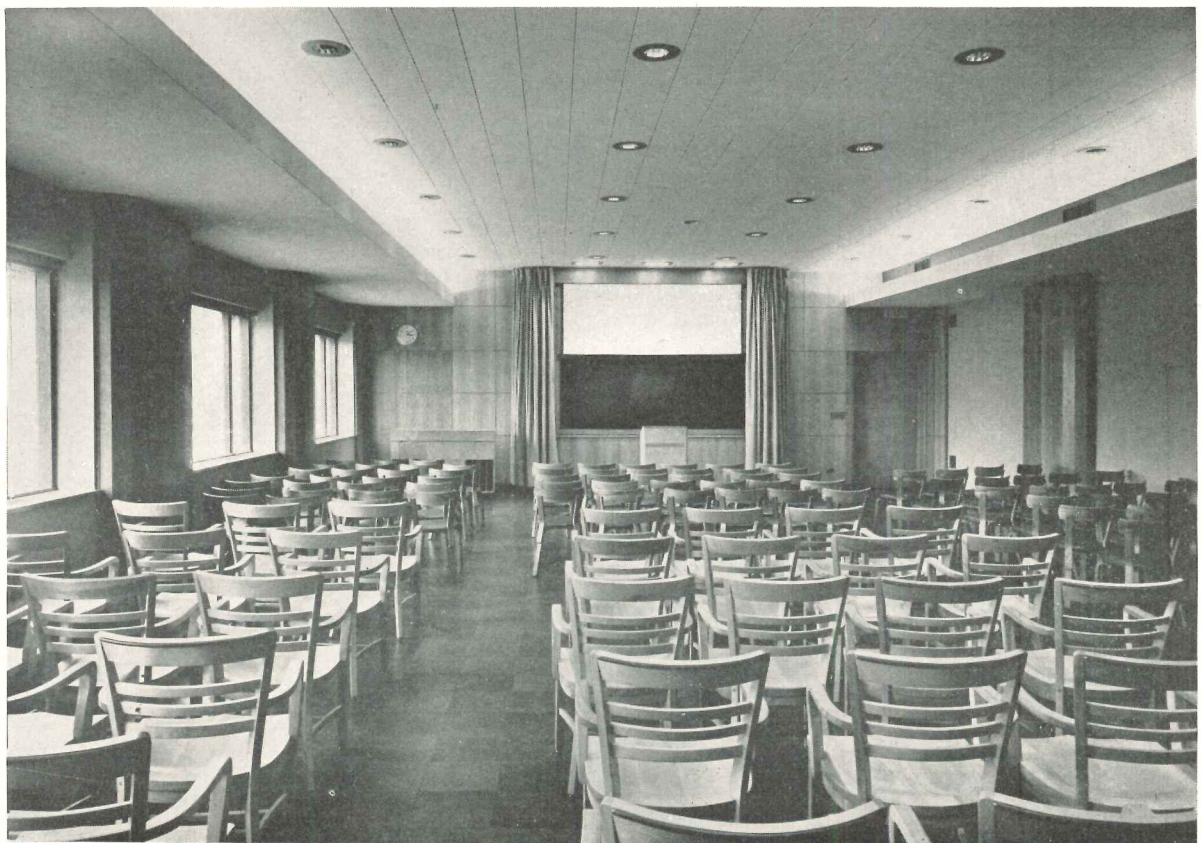



Gottscho-Schleisner Photos

variety of rooms, of accommodations generally, and a change of pace through main areas. Each of the main levels has smoking rooms, where the chatter can be less restrained. Reading areas are broken up into groupings, with various degrees of privacy, and with some comfortable chairs for those who can concentrate only when almost supine.

One of the difficult questions was whether or not to permit the Radcliffe girls to use the Library. For the

time being at least, the girls are excluded. While there are other good reasons, the librarian points out that "experience . . . has shown that a library for men only or for women only can be administered with almost no supervision in the reading rooms, but a coeducational library requires supervision if reasonable quiet is to be preserved." In short, opening the doors to Radcliffe would necessitate doubling the Lamont staff. No use carrying this monotony thing too far!

## PENTHOUSE

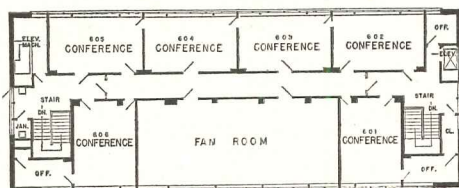

One of the conference rooms, penthouse story

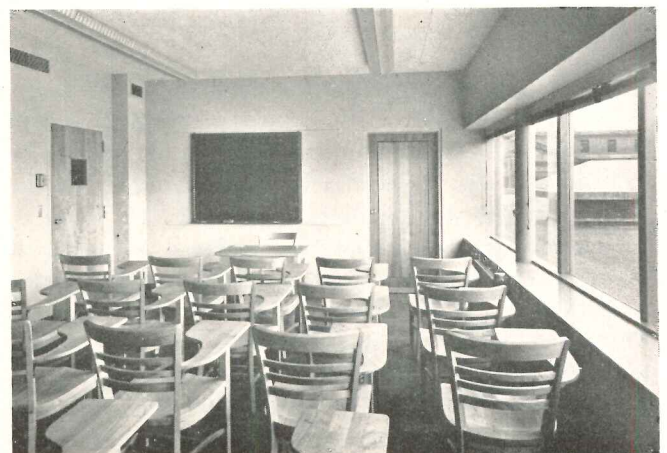

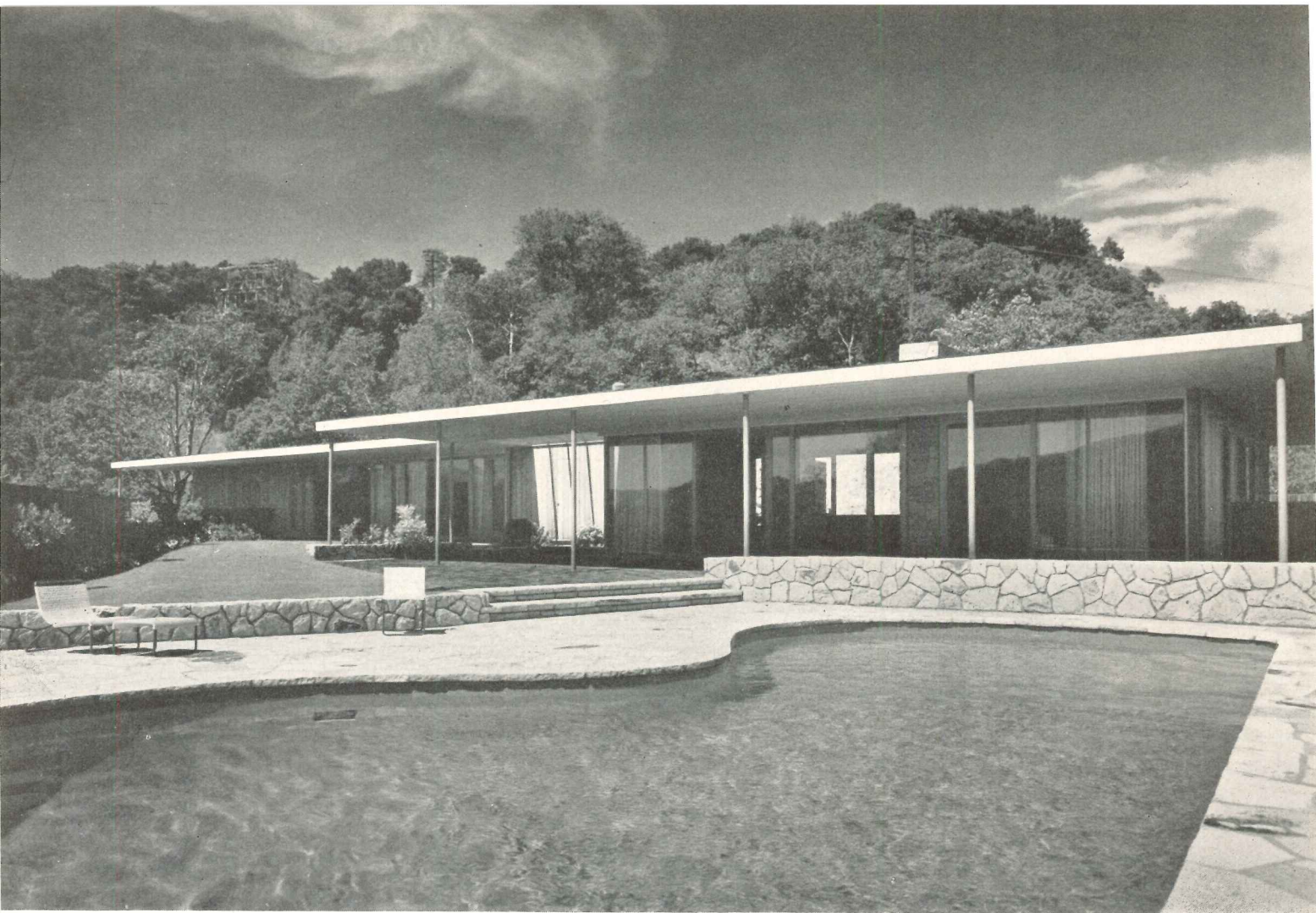

Roger Sturtevant Photos

## DESIGNING WHAT COMES NATURALLY

*"Tamalpais House," North of San Francisco*

*Henry Hill, Architect; Eckbo, Royston and Williams, Landscape Architects*

**I**F this house, by virtue of being published in the magazine, advances the "cause" of architecture, it will probably be because it obviously was not designed to be published in the magazines. It does not bundle up the clichés; it does not flaunt its inventions. Its claim to distinction is the modest naturalness with which it wraps up a pretty expensive package of space. Included in this package is a lush treatment of the outdoors, what with swimming pool, bath house, stone walls and terraces, not to mention the direct floral treatment or the fence to give it all privacy. This naturalness, while readily seen in the photographs, tends to grow

more impressive as one begins to appreciate the scale of the house and its glass areas and views.

It was designed for a man and wife, without children, who specified a one-level house with complete privacy for outdoor living and room for extensive but informal entertaining. The site, overlooking the ubiquitous Mt. Tamalpais, is a pointed corner of hillside leveled down to a convenient driveway level, and well fenced in — for privacy, yes, but also to prevent falling into the valley; it simply wasn't possible for the landscaping to flow gently into the countryside. In fact the fence acts as barrier against the closing in of the wilderness.



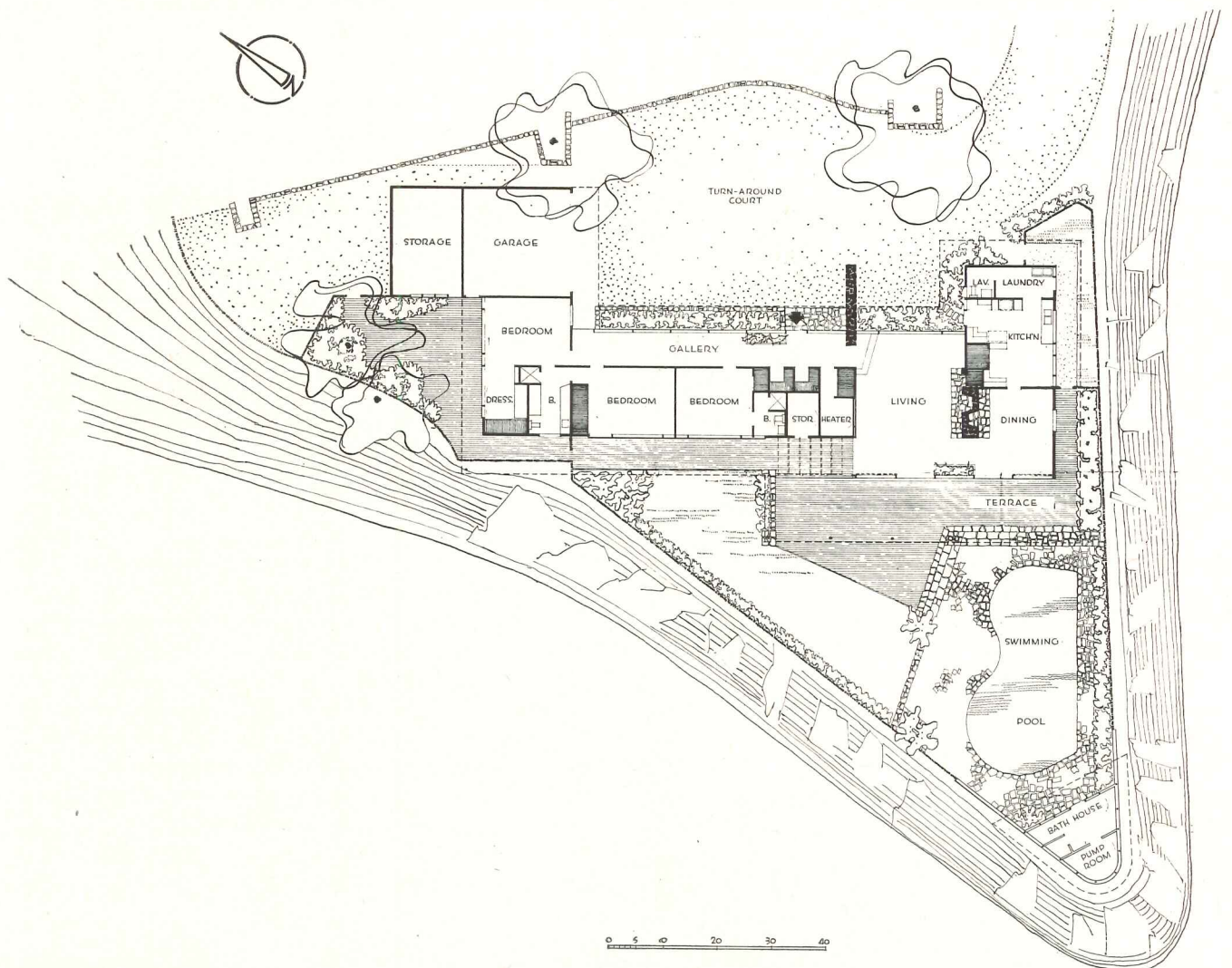
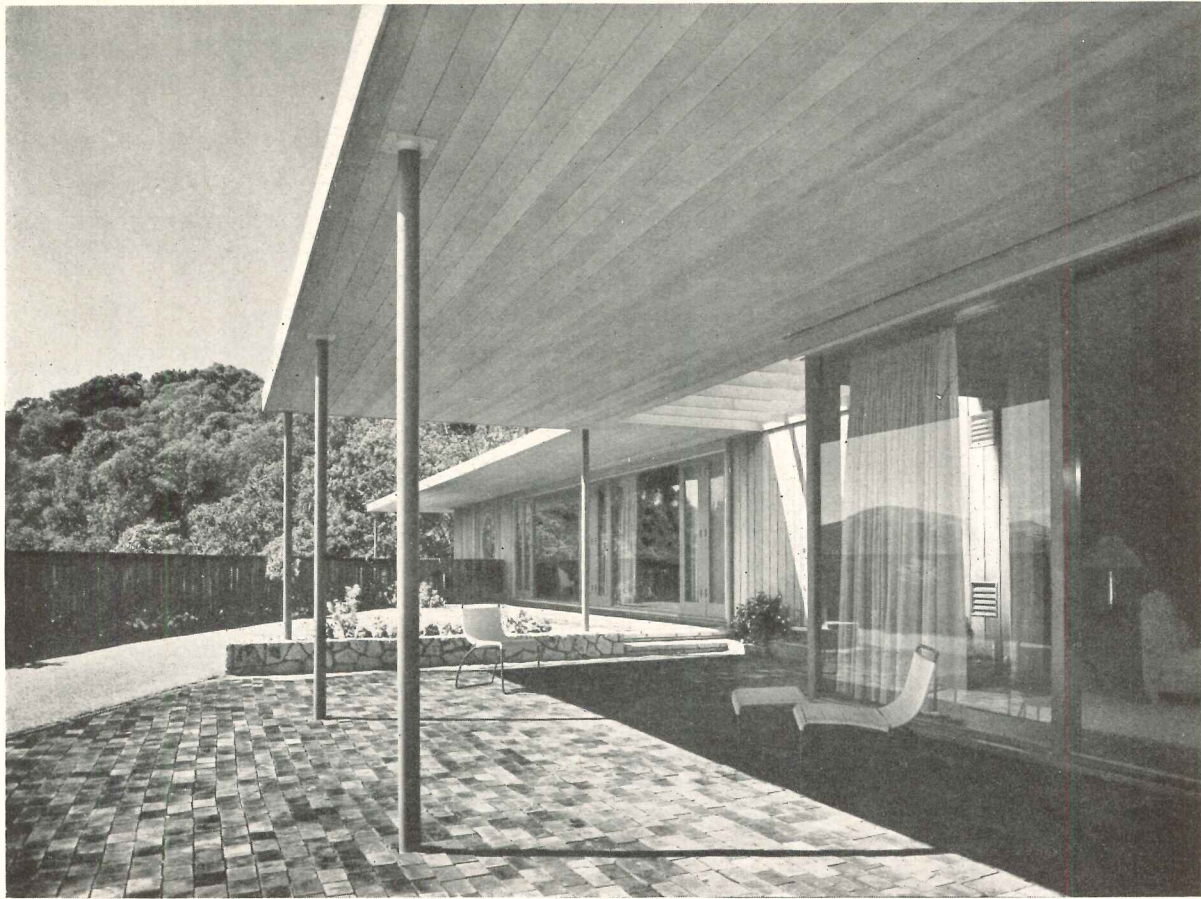

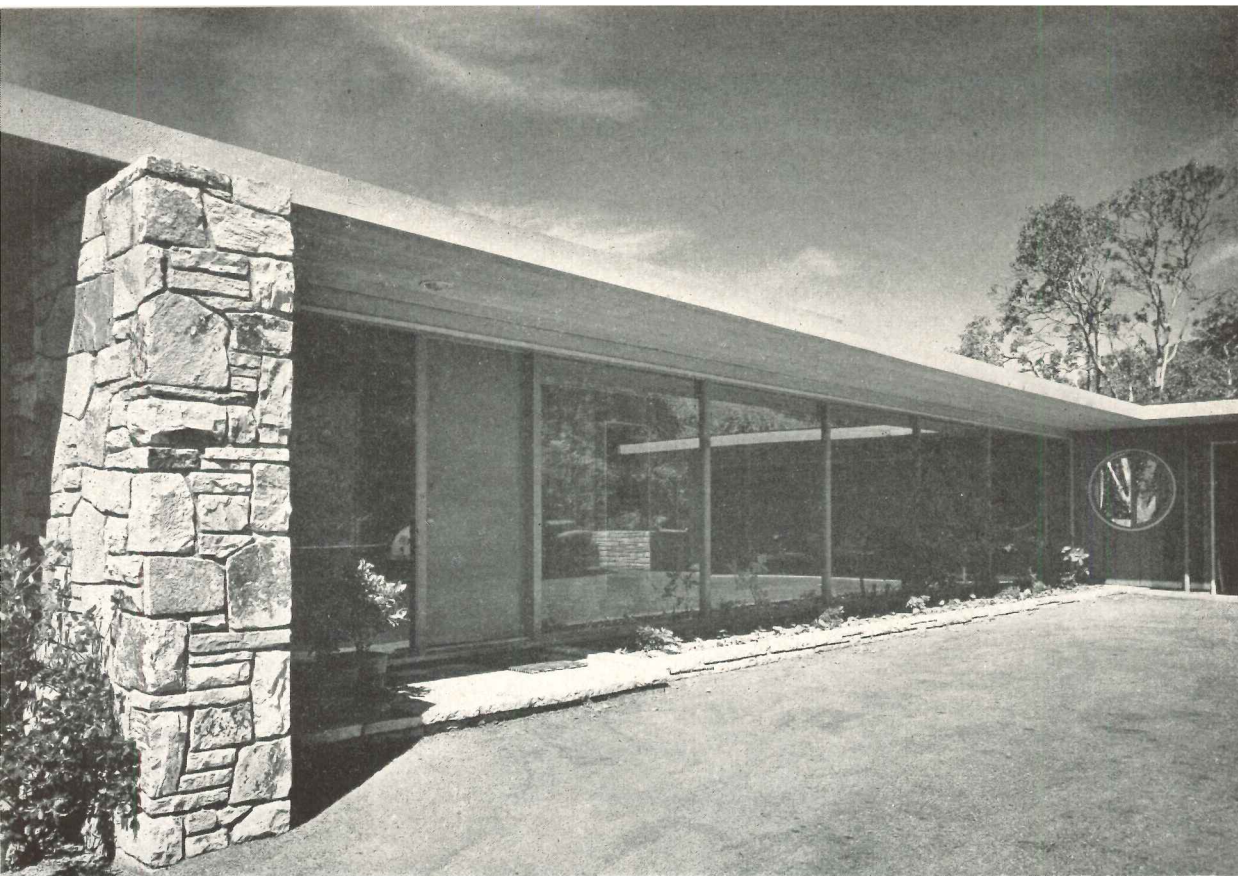

*The glazed gallery (above and below) is the only area opening directly to the approach side of the house, facing the turn-around court. The heavy masonry wall serves to shield the living room from direct gaze of visitors at the entrance door, and the planting strip can be arranged to provide further screening if desirable. Exterior siding is all natural redwood, unfinished and left to weather. The continuous fascia board is painted gold; the front door is painted inside and out a dubonnet wine red*

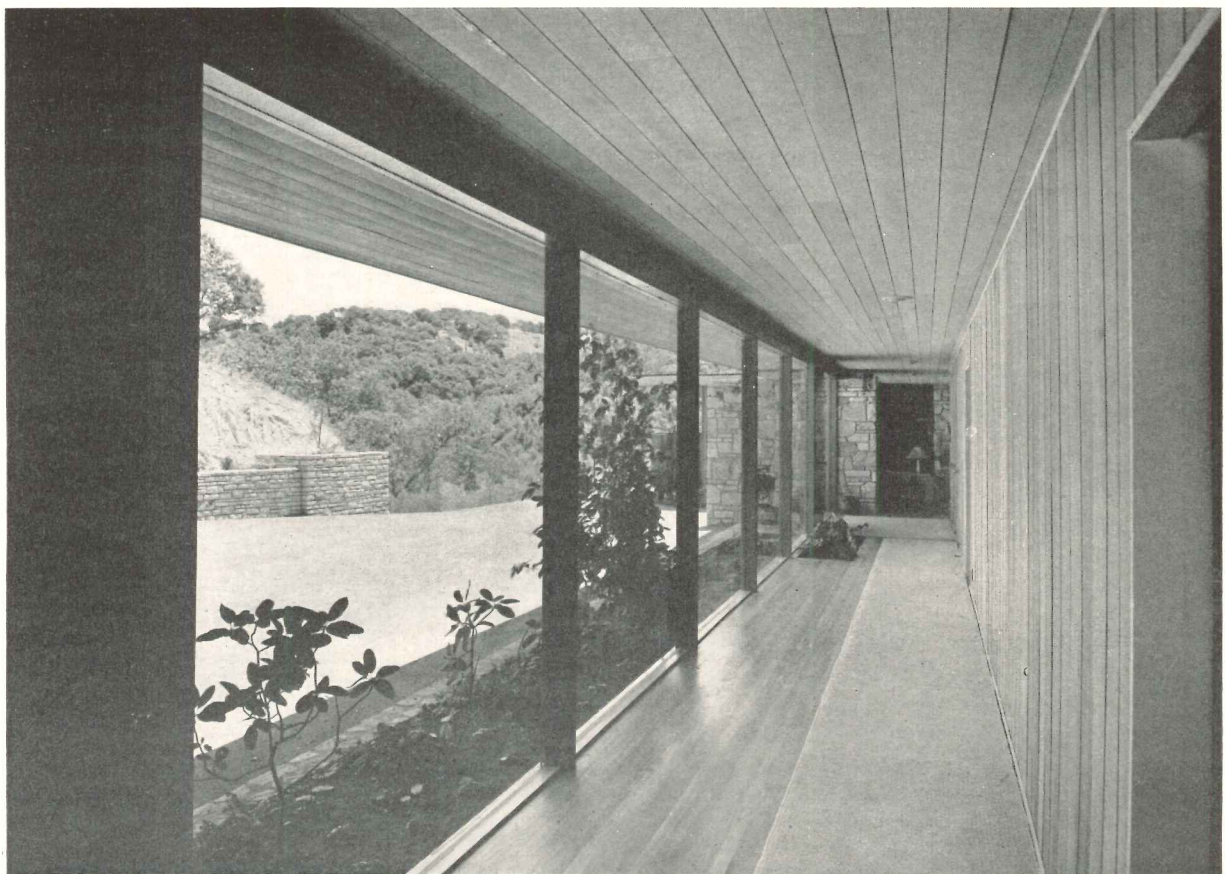

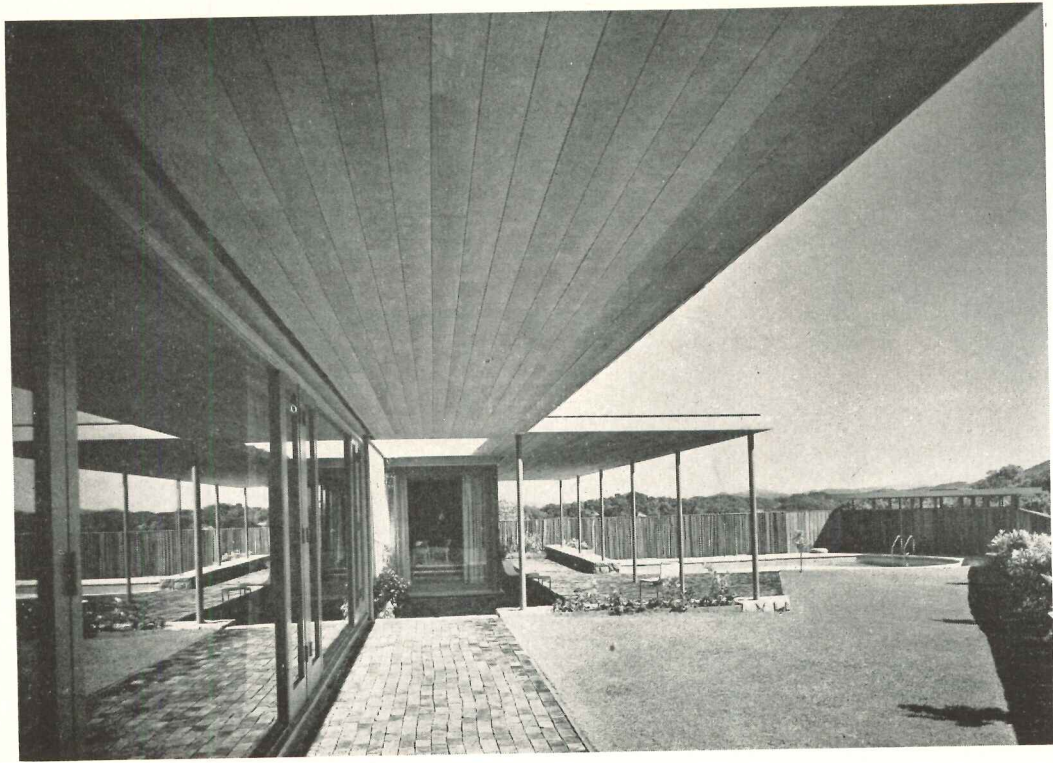

*Eaves at the bedrooms (foreground) are 7 ft. wide; at the living room, 12 ft.; they protect the windows against the western summer sun, but admit the winter sunlight. Terraces under the eaves are paved with redwood blocks, with end grain exposed. The long wall in each bedroom is of pine, stained a gray gold; ceiling is surface pine*

Roger Sturtevant Photos

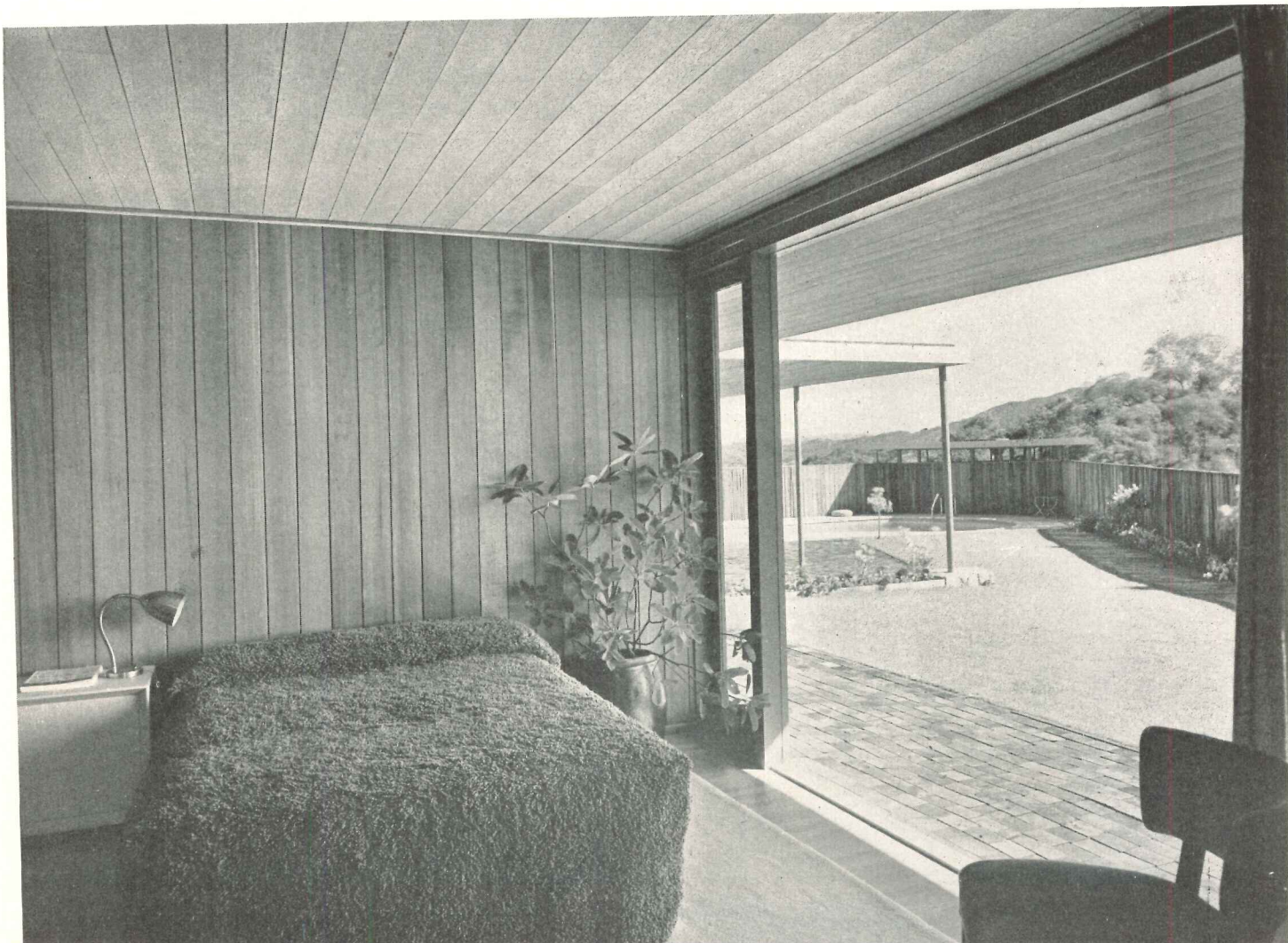

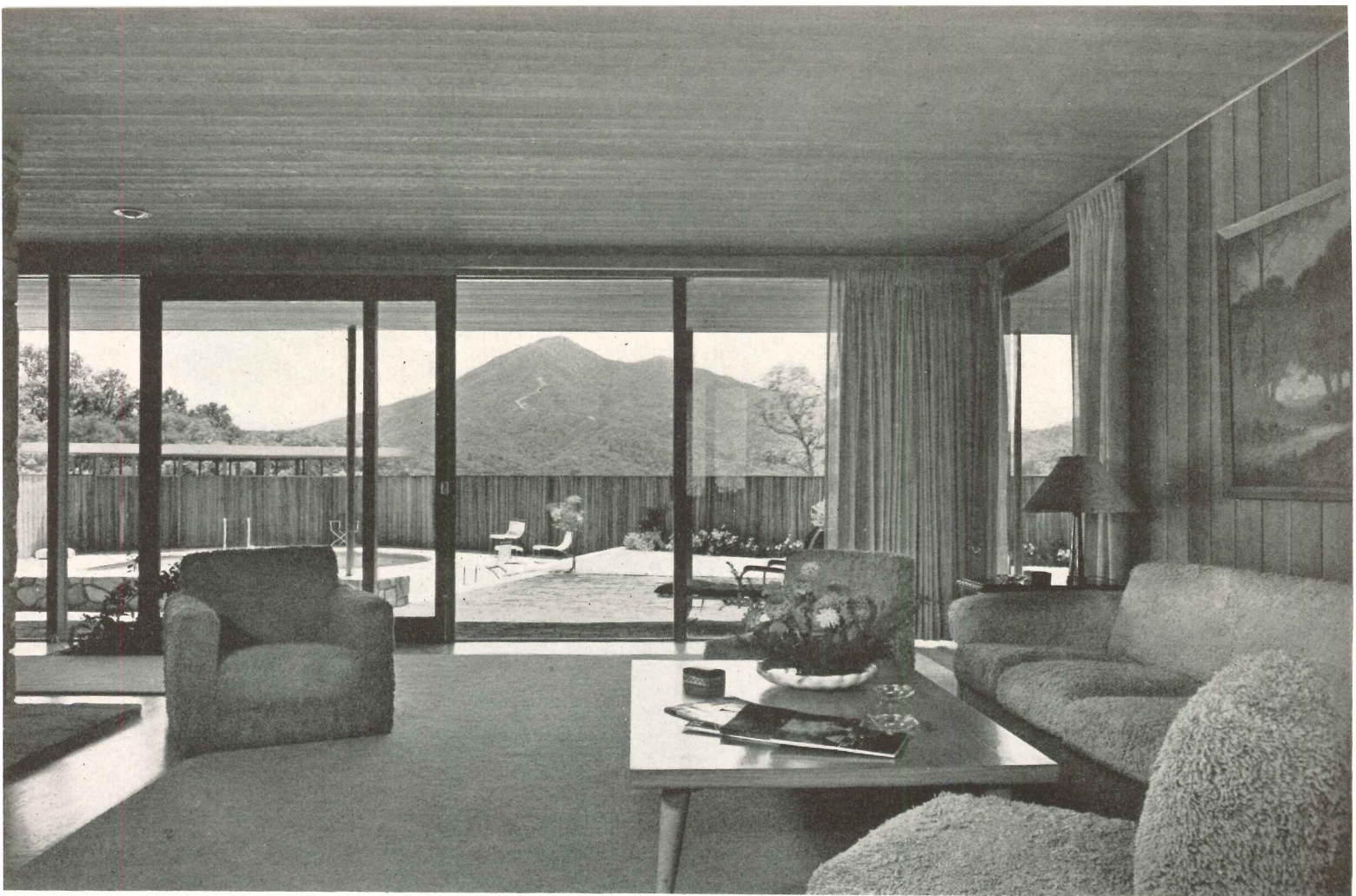

*The upper view of the living room gives some idea of the scale of the house and its vistas. It easily accommodates the massive furniture (by Frank DeWitt), indeed the heavy furniture is really necessary to the room. The heavy masonry at the fireplace also is in scale, as is the huge painting on the opposite wall. Living-dining room walls are natural redwood*



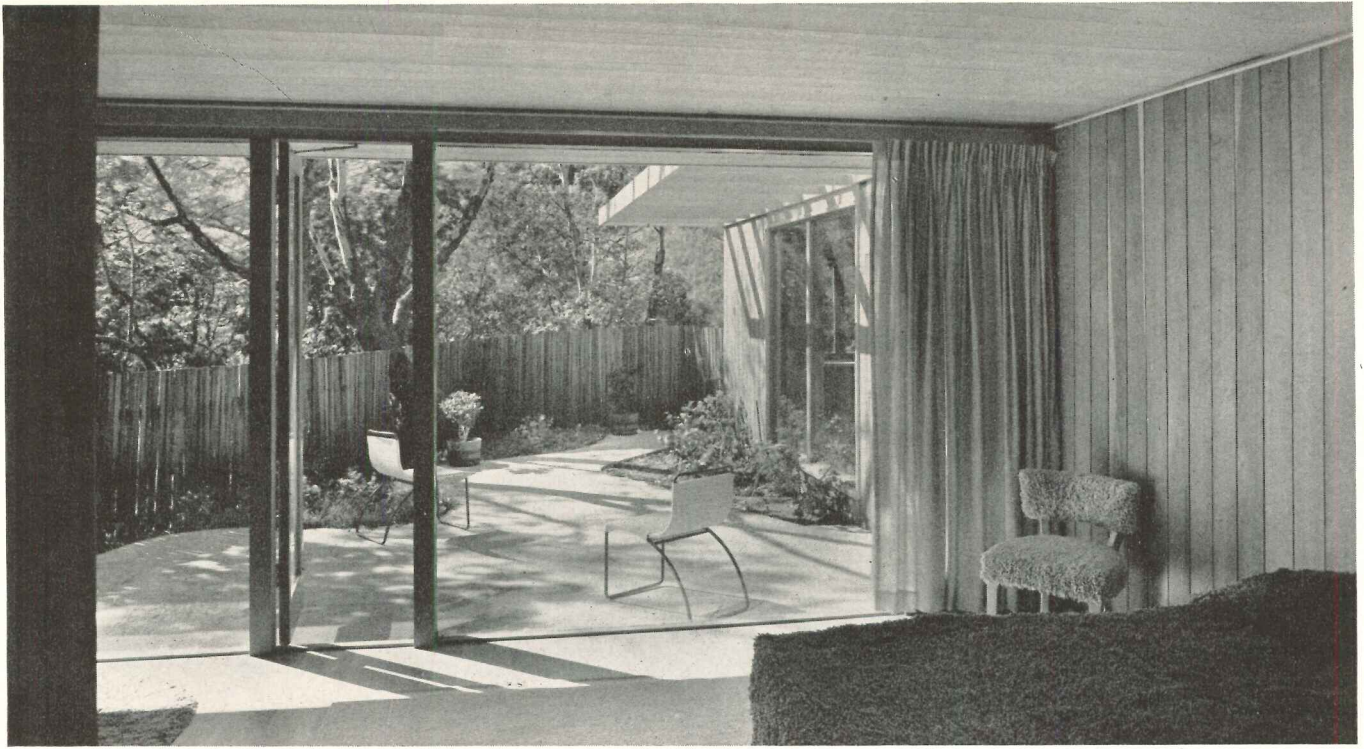

Roger Sturtevant Photos

*The principal bedroom has its glass wall opening into a private garden formed by the outside storage room, the house itself and the last section of the fence. With this assurance of privacy, even the dressing room can have a full glass wall (dressing room and bath at lower right)*

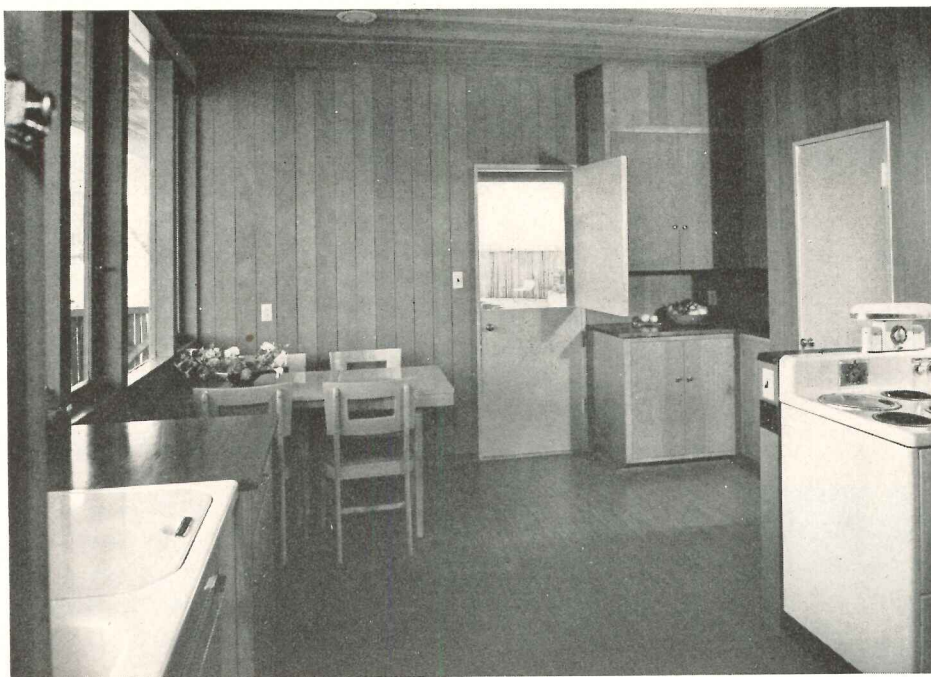
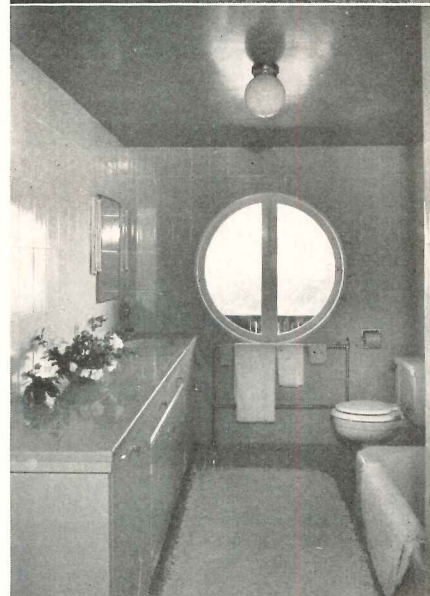
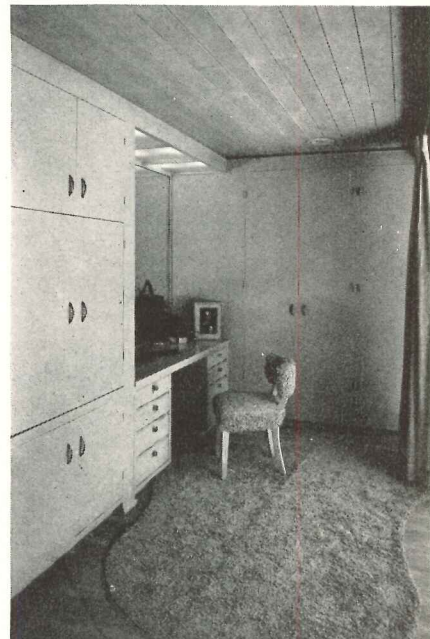



1. Steel Armchair, Mies van der Rohe. 2. Molded Plywood Chair, Haskelite Corp., Saarinen & Eames (Sunami Photo). 3. Floor Lamp, Baldwin Kingrey, Harry Weese. 4. Glass Set, J. & L. Lobmeyr, Adolf Loos. 5. Prefabricated Kitchen-Bath Unit, W. Brooks Cavin, Jr. 6. Storage Wall, Tullio Buzzi (DOMUS). 7. Printed Fabric, Arundell Clarke, Philip C. Johnson. 8. Printed Fabric, Alexander Girard (Astleford Photo). 9. "Primitive Forms," Print, Design Unit New York, Baldwin & Machado

1

2

3

4

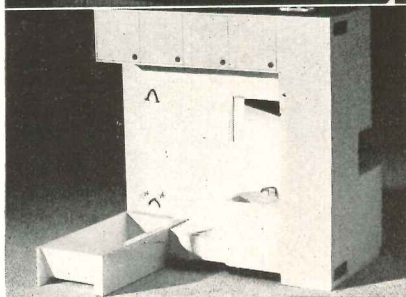
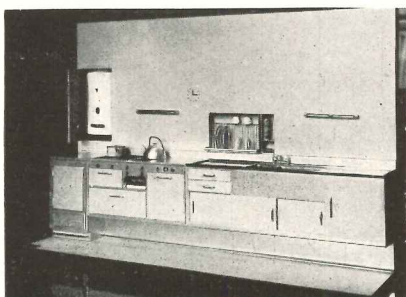
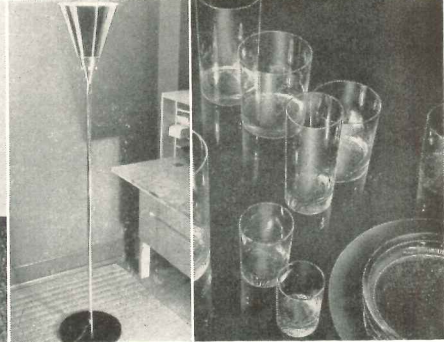
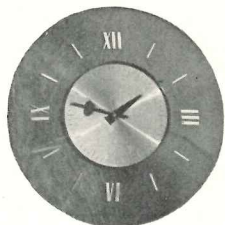
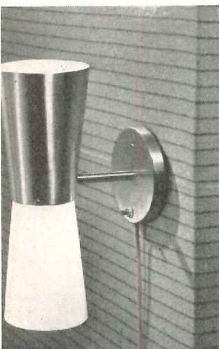

5

6

## ARCHITECTS

THIS is by no means the first report on the activities of architects as industrial designers, but it might well be the last. For architects are doing so much designing for industry that even this attempt to show current work has run into pages and pages of postage-stamp pictures.

It wasn't so many years ago that industrial design was being held out to architects as a new line of activity. But it is really only the phrase that was new — design of objects and products of manufacture 'way back in history was done by the same talent that designed buildings. So in doing it now architects are only doing what their forebears did even before they branched off into "architectural design." This latter was really a specialization of the "master builder" phase of architectural history. During these eras industry went its own way, intent on mechanics and function and superimposed or superficial decoration, and only of late has it appreciated the integral relationship of these to form.

In truth architects, as "industrial designers," are leading the way in organic design — industry got around to wanting "design," but probably what it really sought was, say, "styling for salesmanship." So

Photographs not identified or numbered on this spread appear with proper identification on the following pages

7

8

9

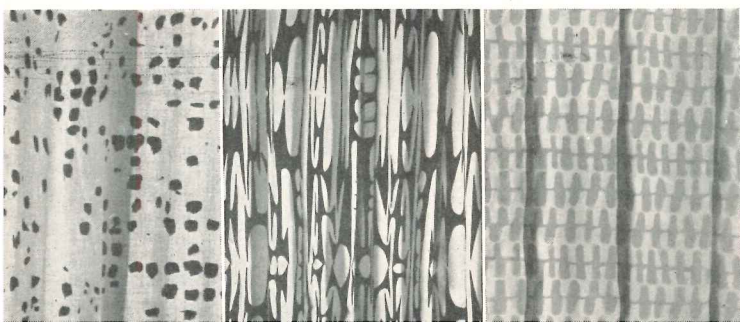

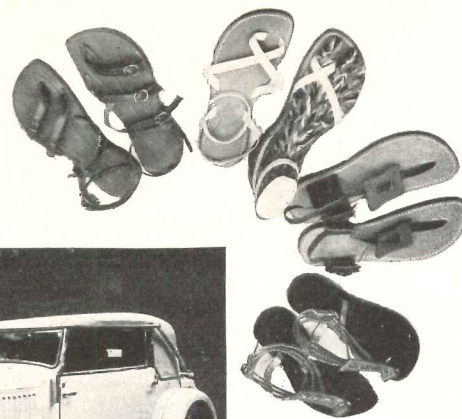
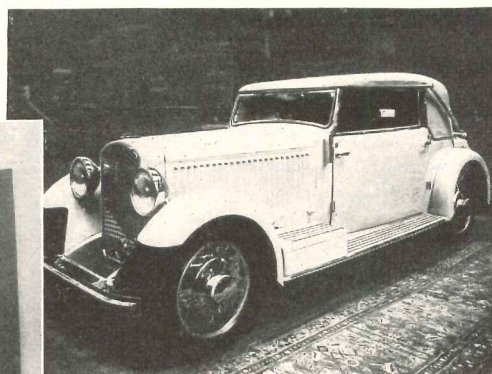
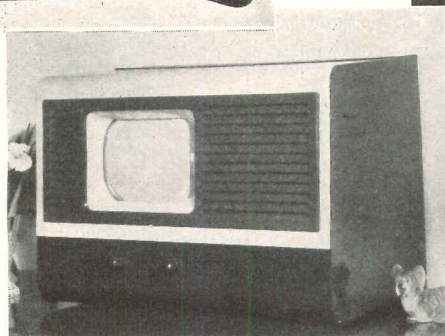
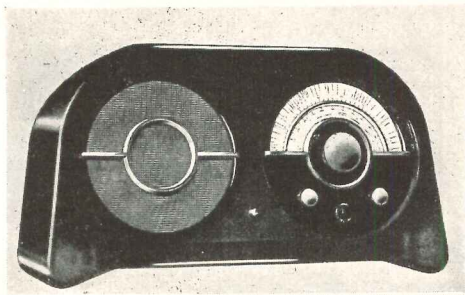

The editors are indebted to the Department of Architecture and Design, Museum of Modern Art, for the privilege of selecting many illustrations from its collections

## DESIGN FOR INDUSTRY

*A current visual report on industrial design by architects, covering products ranging from bathing slippers to mechanical cores for buildings*

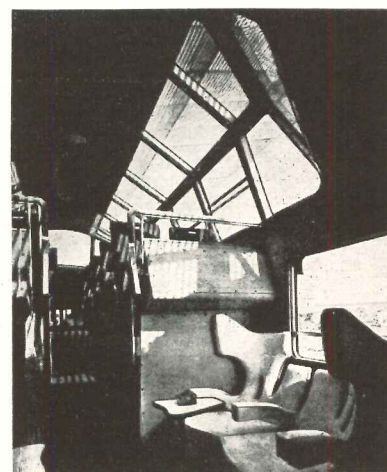

a great deal of what was earlier called industrial design was merely cosmetics on the skin of the product. Now manufacturing generally is getting more benefits than it contemplated when employing architects to pretty up its products. It is getting design, good design, organic design, and therefore economical, efficient and workable design.

In Europe it appears that industrial design has always been done by architects, without the prior intervention, or invention, of the "industrial designer." Some would say that was explained by the fact that architects in Europe did not stray so far from organic design as did those in America, or that they appreciated it earlier, or something of the sort. But it also might be explained by the fact that in Europe industry did not make such "industrial" progress as here, and thus go so far afield from true esthetics. Certainly it is observable, at any rate, that European architects migrating to these shores just naturally expected to design products for industry, and did so, while American architects looked on entranced by this "new field."

The current report, then, is simply that American architects did get into industrial design, and both they

and industry have profited. Indeed, American architects could hardly have stayed out — they were dragged in. Their three-dimensional design talent and training made them naturals for the design problems of industrial products, materials and assemblies. Even if some other group did get there first in acquiring the titles and prerogatives of "industrial designers," the architects were invited in in one way or another. Many have been the "boys in the back room," many have taken commissions themselves, and many have simply got there on the better mousetrap route — they designed hardware, furniture, fabrics, accessories, built-ins and what-nots, until their products began to displace older lines. Names in this category include many of the big names of architecture — Howe & Lescaze, Mies van der Rohe, Breuer, Eames, Aalto, Le Corbusier, Nelson, Saarinen, Koch, etc. ad infinitum.

So the influence of architects — dating back to those unnamed souls who designed double-hung windows, radiators, hardware, and so on — has quietly come to be appreciated to the point where architects are now called in to design all manner of things, until mere size alone may make the next current report impossible.

ARCHITECTS DESIGN FOR INDUSTRY

*Utility Cores and Storage Units*

10. Utility Unit, Ingersoll Steel Division, Borg-Warner Corp., J. Fletcher Lankton (Gie Gaddis Photos). 11. Built-in Kitchen, Thermidor Elec. Mfg. Co., Harwell H. Harris. 12. Mechanical Core, Jane Drew & E. Maxwell Fry. 13-14. Prefabricated Kitchen-Bath Unit, W. Brooks Cavin, Jr. 15. Basic Storage Components, Herman Miller Furn. Co., George Nelson

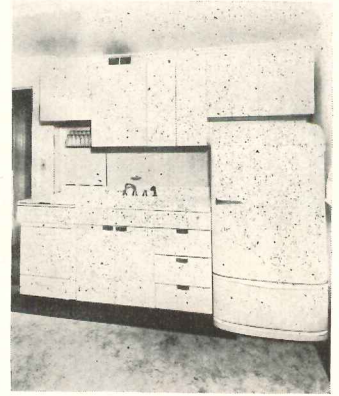

10



11

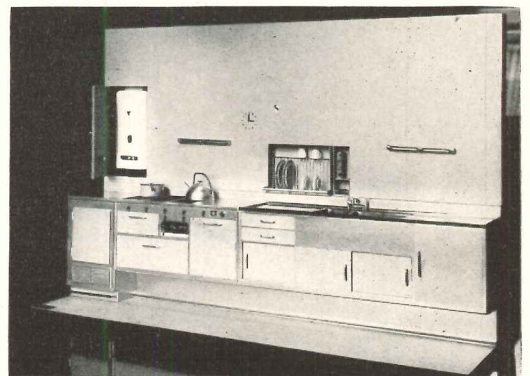

12

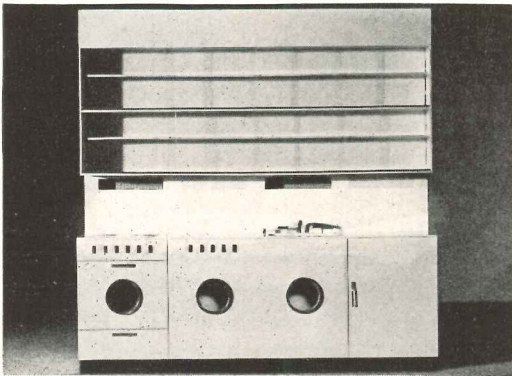

13

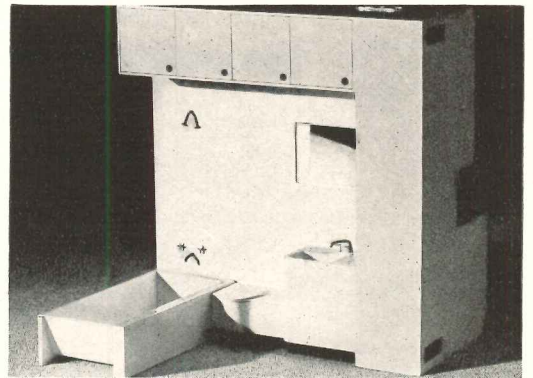

14

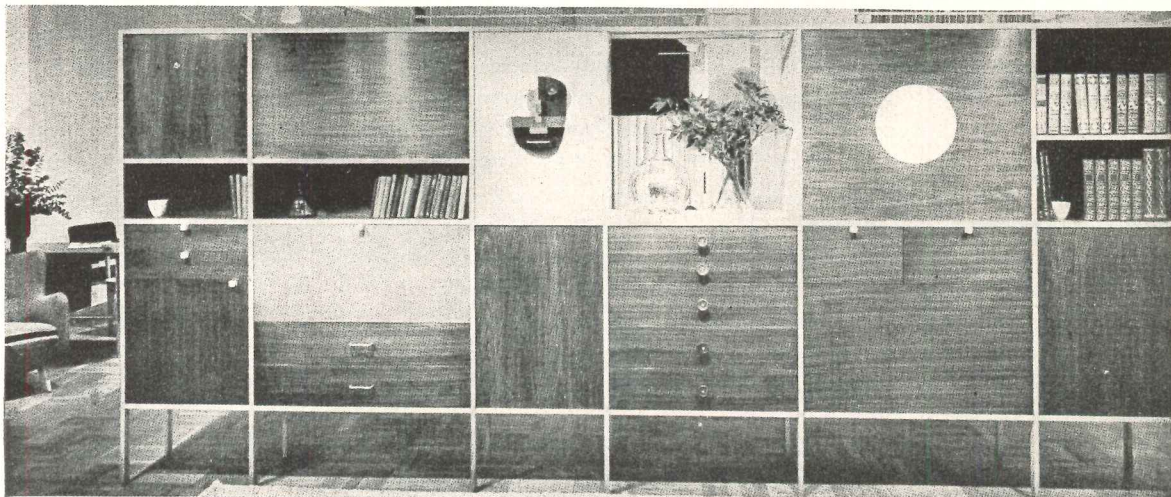

15



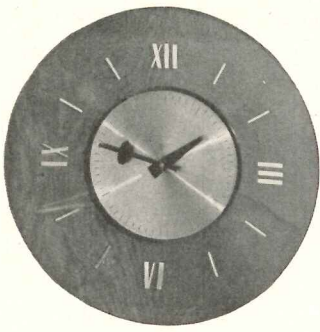

16

16. Electric Clock, Howard Miller Clock Co., George Nelson. 17. Electric Clock, Howard Miller Clock Co., George Nelson. 18. Electric Clock, Howard Miller Clock Co., George Nelson. 19. Clock, Howe & Lescaze (Steiner & Nyholm Photo)

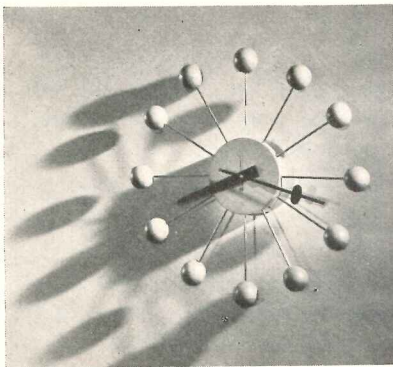

17

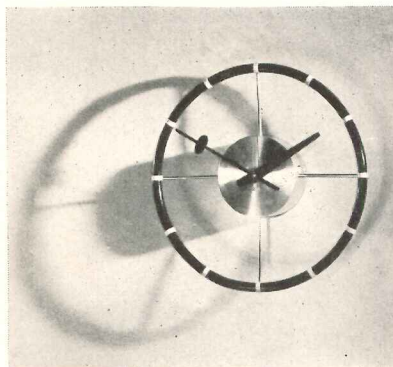

18

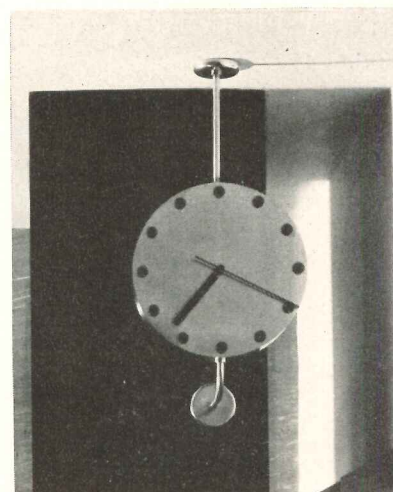

19



20

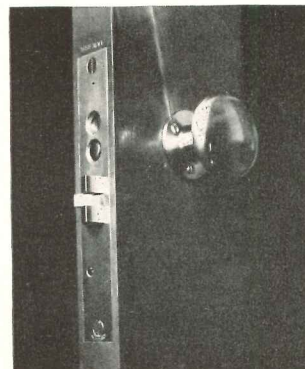

21



22

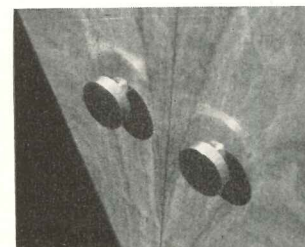

23

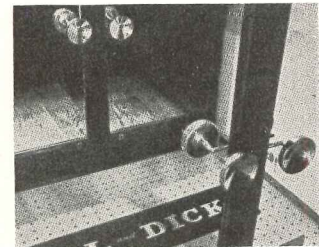

24

20. Door Handle, after designs by Mies van der Rohe. 21. Knob & Lock, P. & F. Corbin, Howe & Lescaze. 22. Door Push, Pietro Balluschi (Stoller Photo). 23. Door Knob, Philip C. Johnson. 24. Door Knobs, Nemeny & Geller (Stoller Photo)

25



26

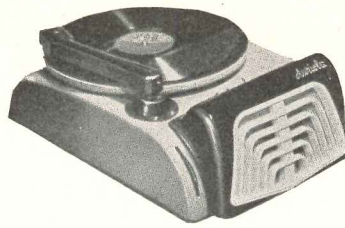

27

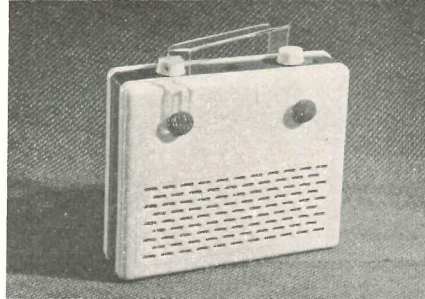
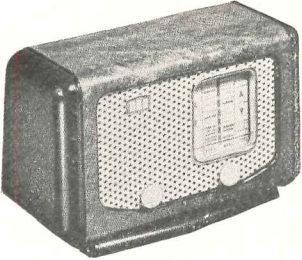

28

29

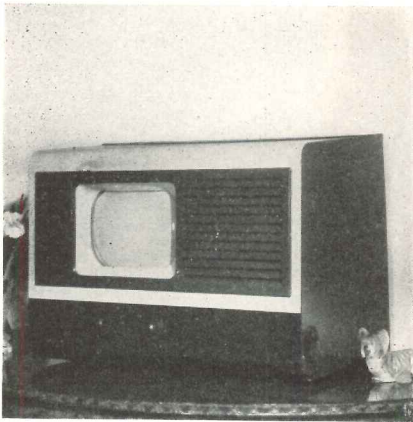

30



25. Radio (1933), E. K. Cole, Ltd., Wells Coates.  
 26-27. Radios designed for mass production in Italy, O. F. Henrich, Milan (Bauen & Wohnen).  
 28. Radio Portable, E. K. Cole, Ltd., Wells Coates.  
 29. Television Set, Ferranti Ltd., Christopher Nicholson.  
 30-31. Radios designed for mass production in Italy, O. F. Henrich, Milan (Bauen & Wohnen).  
 32. Radio (1932), E. K. Cole, Ltd., Serge Chermayeff.  
 33. Radio-Phonograph, Internat'l. Detrola Corp., Al. H. Girard.  
 34-35. Radios designed for mass production in Italy, O. F. Henrich, Milan (Bauen & Wohnen)

31

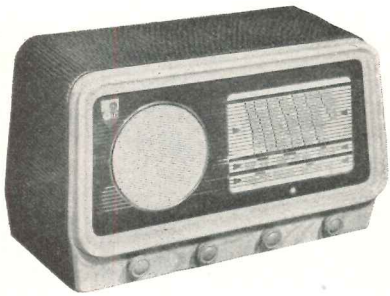

32

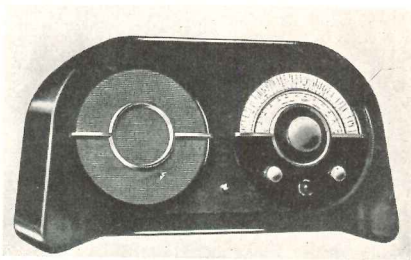

33



34

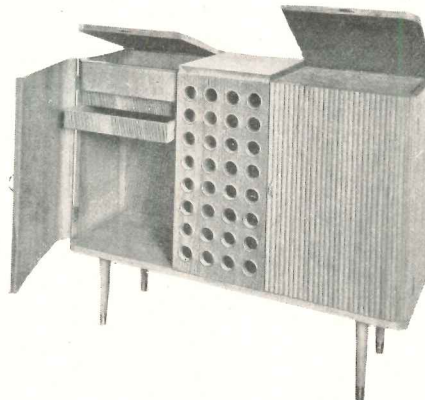

35

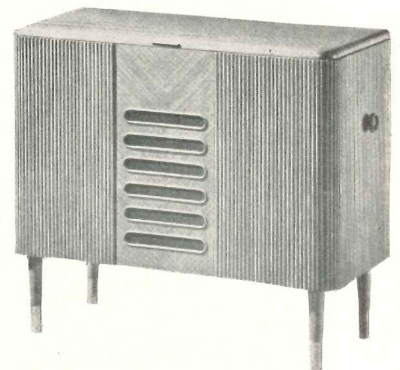

36

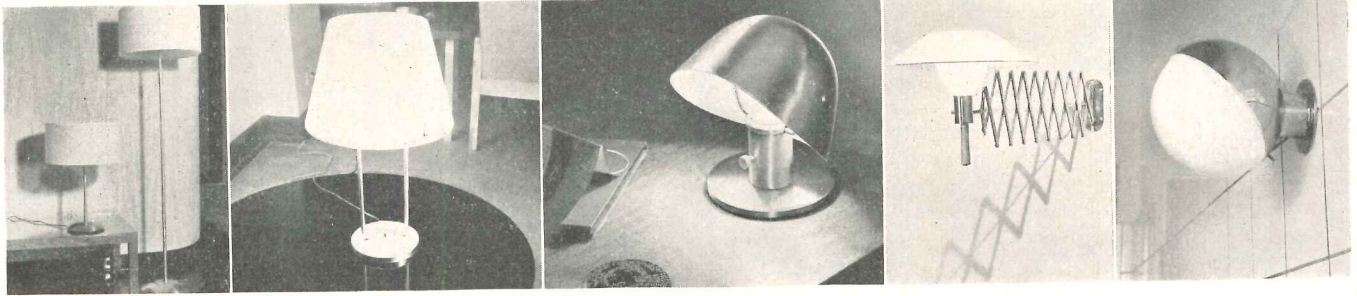
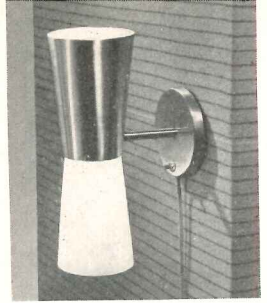

37

38

39

40

41

*Lamps for the Office and Home*

36. Two-Way Wall Lamp, General Lighting, George Nelson (Sanders Photo). 37. Table and Floor Lamps, Victor Pearlman Co., George Fred Keck. 38. Table Lamp, Baldwin Kingrey, Harry Weese. 39. Television Lamp, General Lighting Co., George Nelson (Sanders Photo). 40. Wall Bracket Extension Lamp, General Lighting, George Nelson (Sanders Photo). 41. Wall Fixture, State Radiohouse Copenhagen, Vilhelm Lauritzen. 42. Fluorescen Desk Lamp, Mutual Sunset, Weese & Baldwin (Sunami Photo). 43. Desk

Lamp, Kurt Versen, Howe & Lescaze. 44. Table Lamp, Mutual Sunset, Weese & Baldwin (Fenn Photo). 45. Gooseneck Desk Lamp, Mutual Sunset, Peter Pfisterer (Sunami Photo). 46. Two High Arms, Mutual Sunset, Peter Pfisterer (Fenn Photo). 47. Two Arm Floor Lamp, Mutual Sunset, Peter Pfisterer (Fenn Photo). 48. Standard Lamp, New Design, Philip C. Johnson (Lundquist Photo). 49. Floor Lamp, Mutual Sunset, Peter Pfisterer (Fenn Photo). 50. Gooseneck Floor Lamp, Mutual Sunset Lamp Mfg. Co., Weese & Baldwin (Fenn Photo)

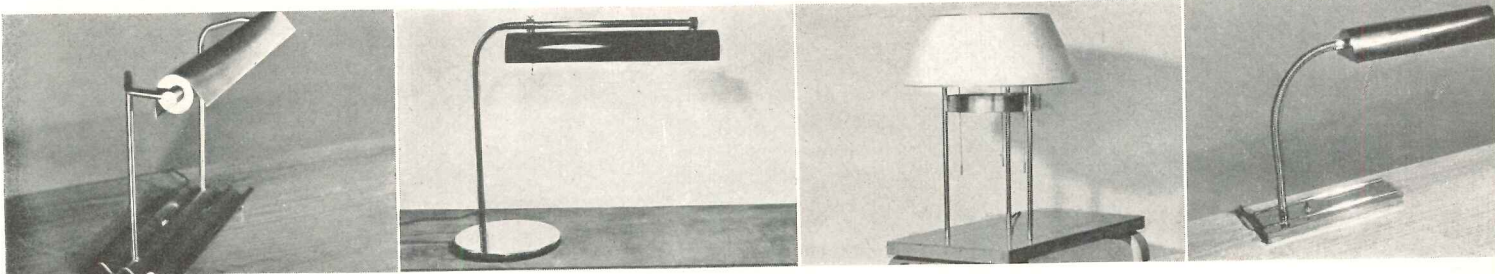

42

43

44

45

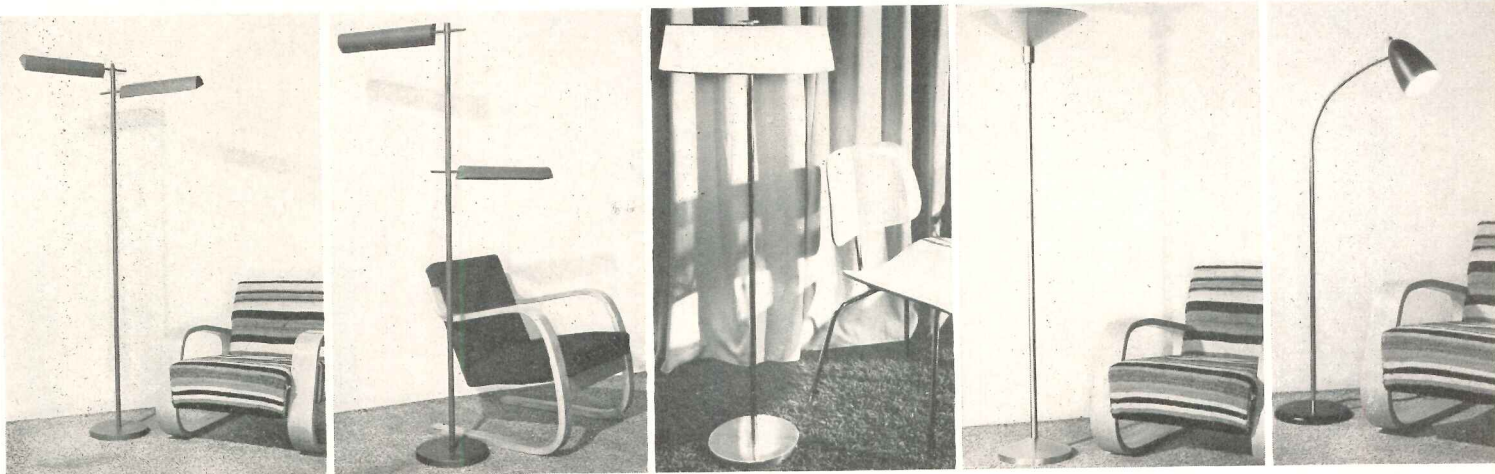

46

47

48

49

50

ARCHITECTS DESIGN FOR INDUSTRY

*Metal Chairs*

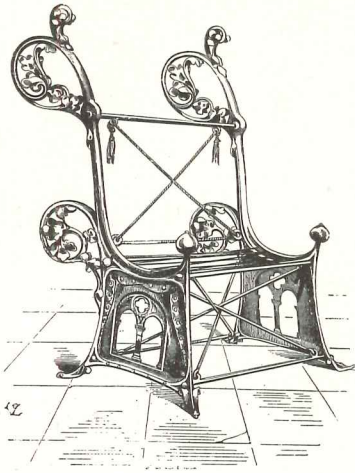

51



52



53



54



55



56

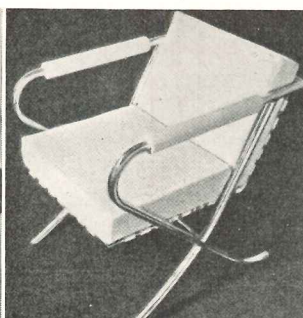

57

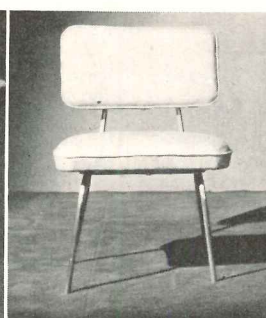

58

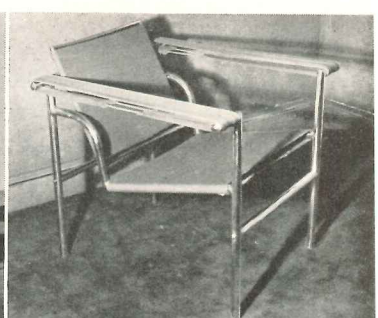

59



60

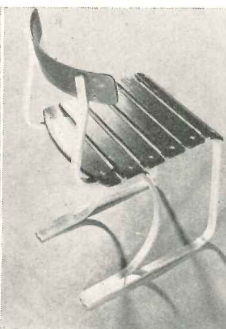

61



62



63

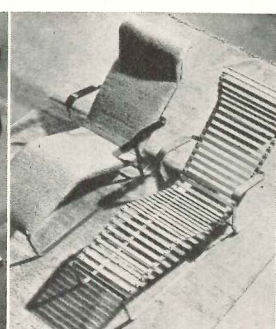

64

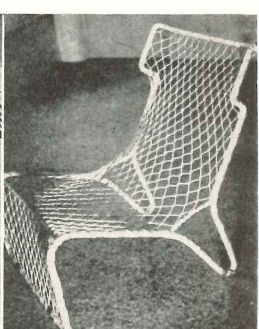

65



66



67

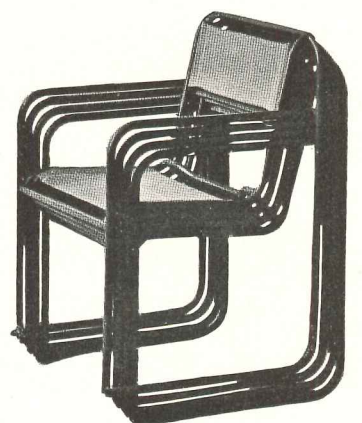

68

Garden Equipment

69

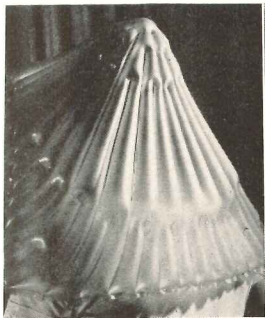

70

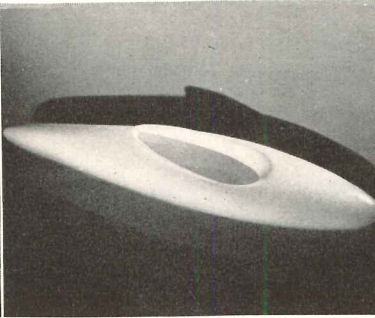

71



72



73

51. Chair (1872), Dictionnaire Raisonné du Mobilier Français, M. Viollet Le Duc. 52. Steel Chair, Mies van der Rohe. 53. Tubular Steel Chair, Thonet, Marcel Breuer. 54. Tubular Steel Chair, Mies van der Rohe. 55. Upholstered Steel Chair (1949), H. G. Knoll, Mies van der Rohe. 56. Armchair, Hans Knoll, Serge Chermayeff. 57. Steel Armchair, Metz en Co., J. J. P. Oud. 58. Chair, Herman Miller Furn. Co., George Nelson (Stoller Photo). 59. Steel Chair, Thonet, Le Corbusier. 60. Steel Chairs, Metz en Co., J. J. P. Oud. 61. Aluminum Garden Chair (1933), Marcel Breuer. 62. Molded Plywood Chair, Herman Miller Furn. Co., Charles Eames (Sunami Photo). 63. Aluminum Chair (1933), Paris Competition, Marcel Breuer. 64. Aluminum Chairs, Wohnbedarf, Marcel Breuer. 65. Iron Garden Chair, Luigi Vietti. 66. Wood Slat chair, Lloyd Mfg. Co., Weese & Baldwin. 67-68. Stacking Chairs, P. E. L., Serge Chermayeff. 69. Terrace Chair, John B. Salterini, Bernard Rudofsky (Richardson Photo). 70. Protective Headgear of Inflated Vinylite, Gallowhur Chem. Corp., Wm. H. Miller, Jr. 71. Collapsible Vinylite Boat, Gallowhur Chemical Corp., Wm. H. Miller, Jr. 72. Saddle Stool, Design Unit New York, Benjamin Baldwin (Melton Photo). 73. Barbeque Wagon, Lloyd Mfg. Co., Weese & Baldwin. 74. Barbeque Wagon, Lloyd Mfg. Co., Weese & Baldwin. 75. Barbeque Wagon, Lloyd Mfg. Co., Weese & Baldwin. 76. Table and Bench, Lloyd Mfg. Co., Weese & Baldwin. 77. Canvas Cot, Lloyd Mfg. Co., Weese & Baldwin



74



75

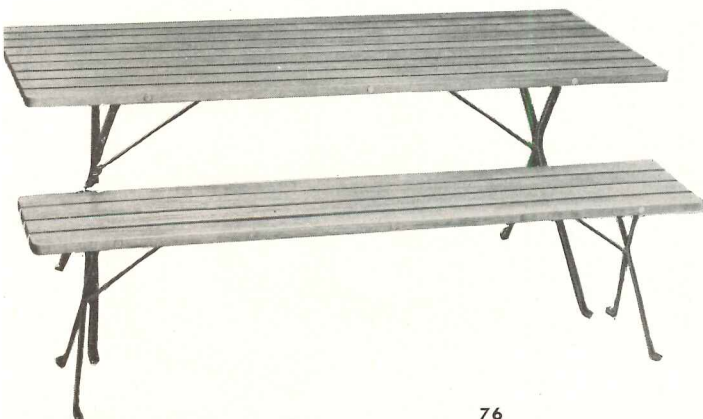

76

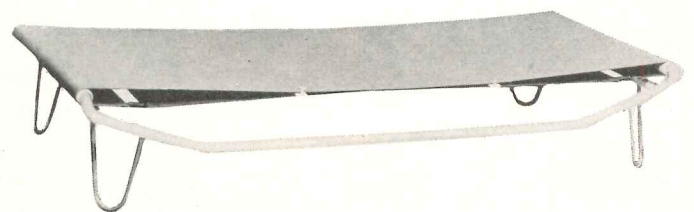

77

109

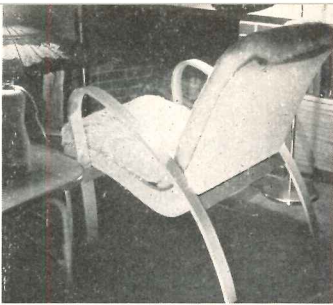

78



79



80



81



82



83



84

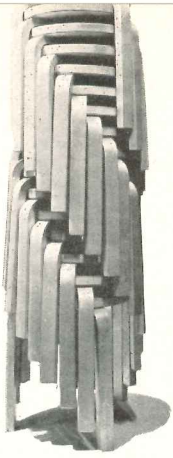

85



86

## ARCHITECTS DESIGN FOR INDUSTRY

### *Chairs*

78. Armchair, Carl Koch. 79. Easy Chair, H. G. Knoll, Eero Saarinen. 80. Reclining Chair, Isokon, Marcel Breuer (Russo Photo). 81. Reclining Chair, H. G. Knoll, Eero Saarinen (Gildart Photo). 82. Molded Plywood Nursery Chair, Charles Eames. 83. Side Chair, Carl Koch. 84. Arm Chair, Svenska Moebel., Axel Larsson. 85. Stacking Stools, Alvar Aalto. 86. Molded Plywood Chair, Charles Eames. 87. Molded Plywood Side Chairs, Haskelite Corp., Saarinen & Eames. 88. Upright Chairs, H. G. Knoll, Abel Sorensen (Stevens Photo)



87



88

**Beds, Tables, Sofas**

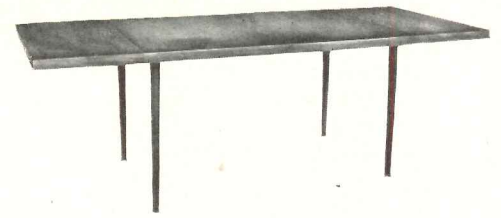

89

89. Dining Table, Red Lion Furn. Co., Saarinen & Eames. 90. Bed, Red Lion Furn. Co., Stonorov & von Moltke (Sunami Photo). 91. Couch, Red Lion Furn. Co., Stonorov & von Moltke (Sunami Photo). 92. Dining Table, Herman Miller Furn. Co., Charles Eames (Eames Photo)

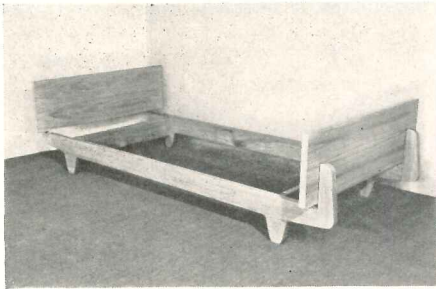

90



91

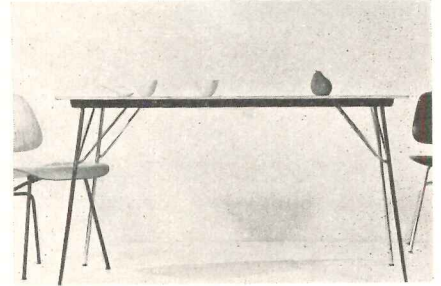

92

**Desks, Dressers, Bookcases**

93. Unit Cabinets, Red Lion, Stonorov & von Moltke. 94. Desk and Chair, Red Lion Furn. Co., Stonorov & von Moltke (Fenn Photo). 95. Unit Cabinets, Charles Eames. 96. Drafting Desk, Bodafors, Axel Larsson



93



94

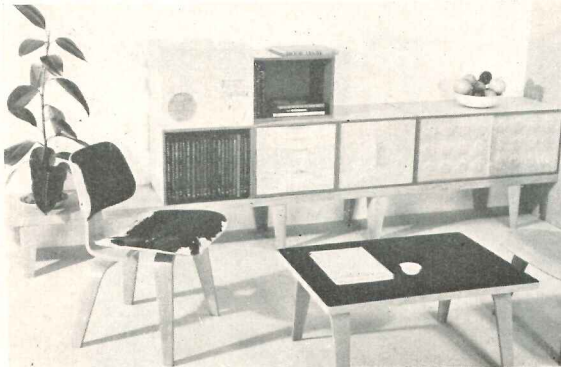

95

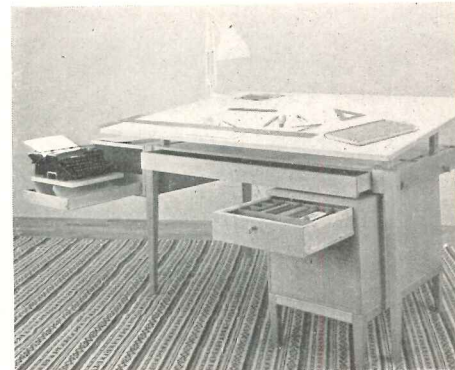

96



97



98



99

**Glassware**

97-99. Glass Sets, J. & L. Lobmeyr, Josef Hoffman. 100. Glassware, Alvar Aalto (Sauren Photo). 101. Table Glassware, Rheinische Glasshuetten (1901), Peter Behrens. 102. Vases, Artek, Alvar Aalto (Sunami Photo). 103. Brass Ashtray, Jacobsen & Moller (Hammerschmidt Photo). 104. Flatware, Dominioni & Castiglioni, Milan. 105. Andirons, Mario Corbett. 106. Flower Pot, Kuenstlerwerkstaetten, Josef Hoffman (Gerlach Photo)

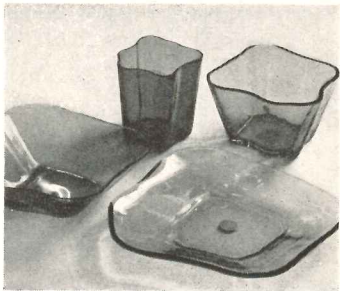

100

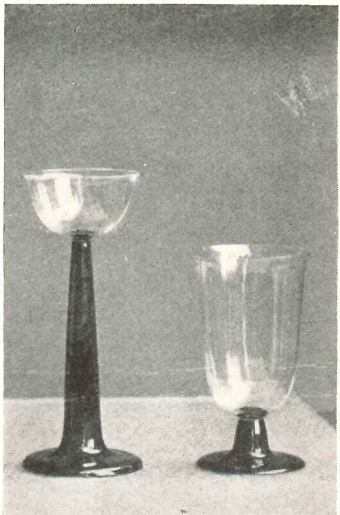

101

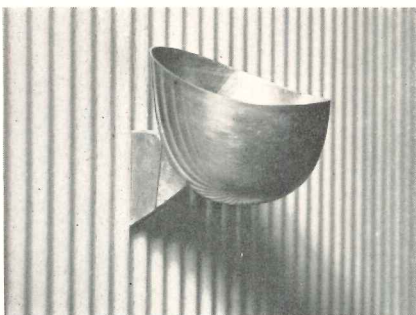

103

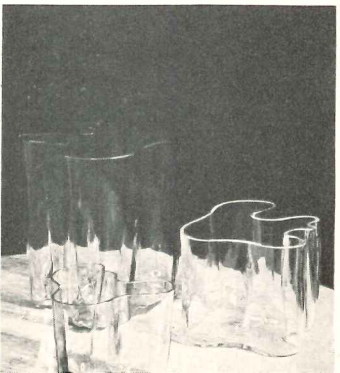

102

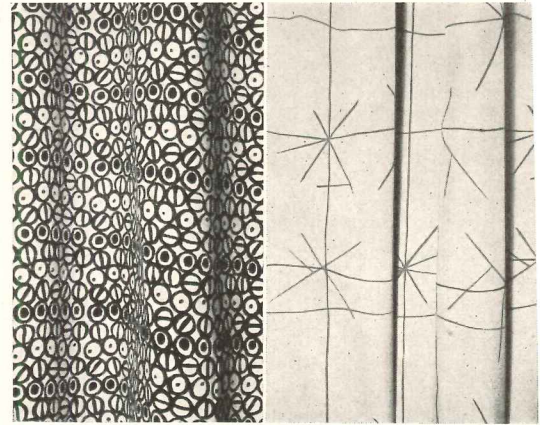

107

108

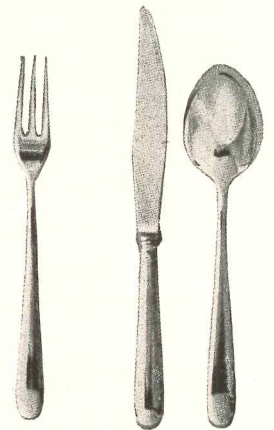

104

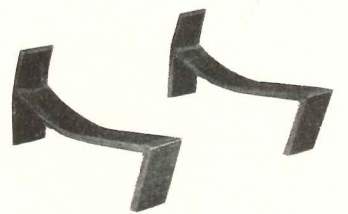

105

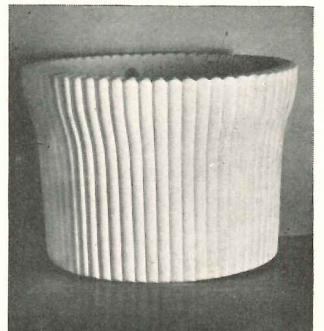

106



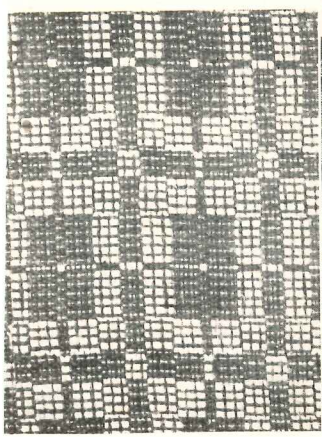

109

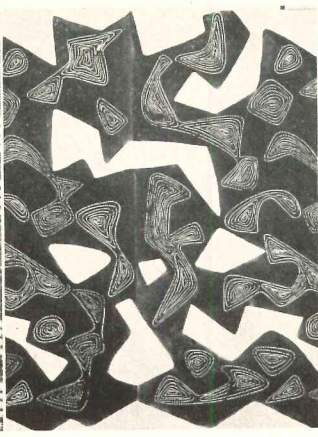

110

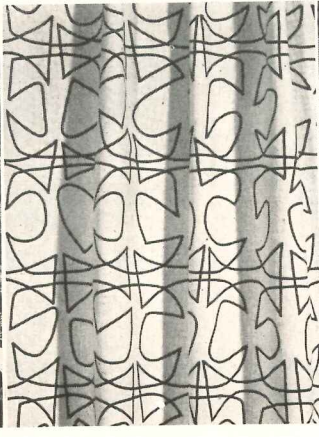

111



112



113

**Fabrics**

107. "Barrel Heads," Print, Design Unit New York, Baldwin & Machado (Melton Photo). 108. "Starry Pines," Print in green and grey, Baldwin Kingrey, Baldwin & Machado (Melton Photo). 109. Voorhees, Walker, Foley & Smith. 110. Concentric Lines on Blue Fields on White Ground, Print, Alexander

Girard (Sunami Photo). 111. Printed Fabric, Alexander Girard (Astleford Photo). 112. Brown, Yellow and Purple Print, Girard, Saarinen & Eames (Sunami Photo). 113. "Flight," Print in any color on yellow background, Baldwin Kingrey, Baldwin and Machado (Melton Photo)

**ARCHITECTS DESIGN FOR INDUSTRY**

**Shoes and Stockings**

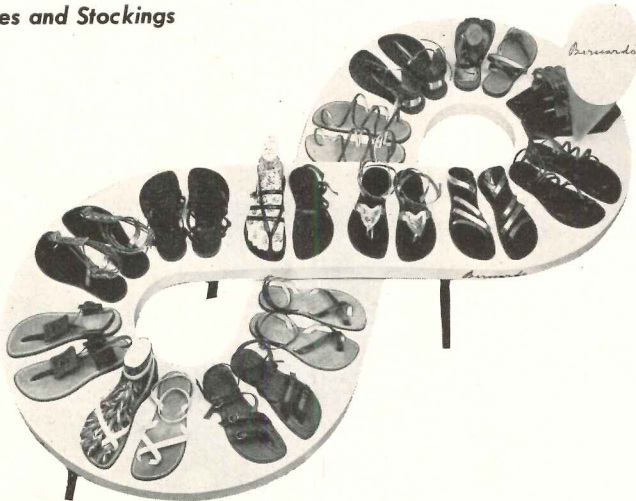

114



115

114. Sandals, Bernard Rudofsky. 115. "Glove" Stockings, Bernard Rudofsky

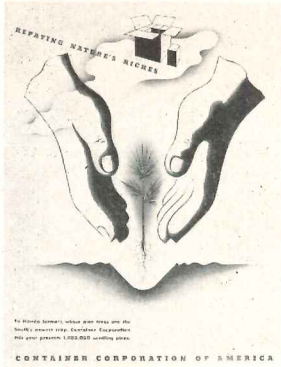

116



117

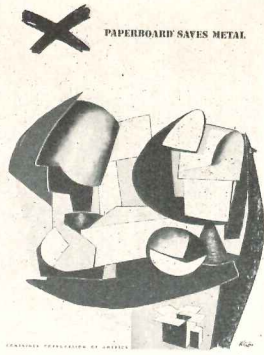

118

**Advertisements**

116. Advertisement, Container Corporation of America (1942), Jean Carlu. 117. Advertisement, Container Corporation of America (1945), Adolfo Halty-Dubé. 118. Advertisement, Container Corporation of America (1943), Jean Hélon

**ARCHITECTS DESIGN FOR INDUSTRY**

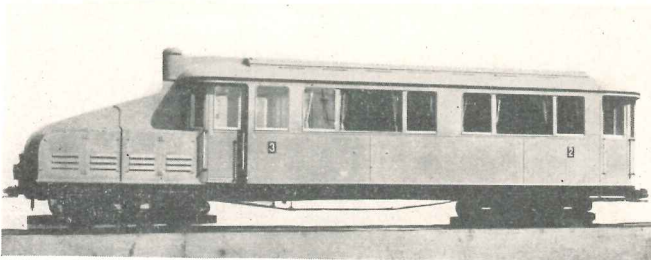

121

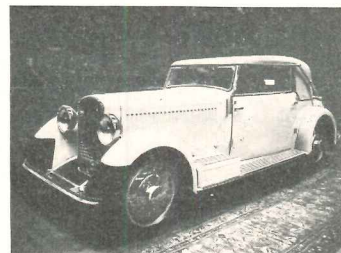

122

121. Diesel Engine Cab, Danzig (1914), Walter Gropius. 122. Convertible, Adler Works (1929), Walter Gropius

**Transportation**

123. Upper Observation Dome, California Zephyr, Chicago, Burlington & Quincy Railroad, Harbeson, Hough, Livingston & Larson. 124. Lounge, Empire State Express, New York Central Railroad, Paul P. Cret. 125. Tavern Lounge, Florida East Coast Railroad, Harbeson, Hough, Livingston & Larson. Photos courtesy of The Budd Company

123



124



125





119

### Electric Typewriters

119. Electric Typewriter, International Business Machines, Eliot Noyes Designer (Norman Bel Geddes & Co.). 120. Electric Typewriter with Carbon Ribbon Attachment, International Business Machines, Eliot Noyes Designer (Norman Bel Geddes & Co.)

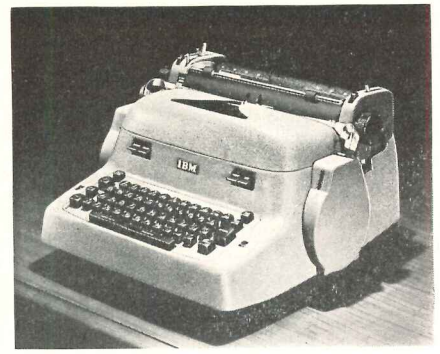

120

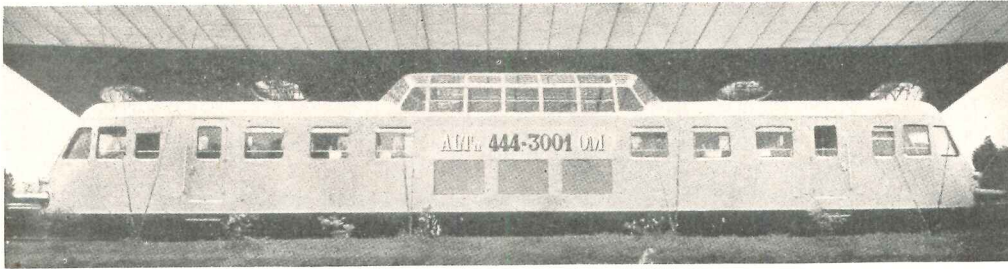

126

126. Electric Train, Italian Railroads, Renzo Zanavella (DOMUS). 127. Platform Shelter, Milan, Renzo Zanavella (DOMUS). 128-129. Train Interior, Renzo Zanavella (DOMUS)

127



128

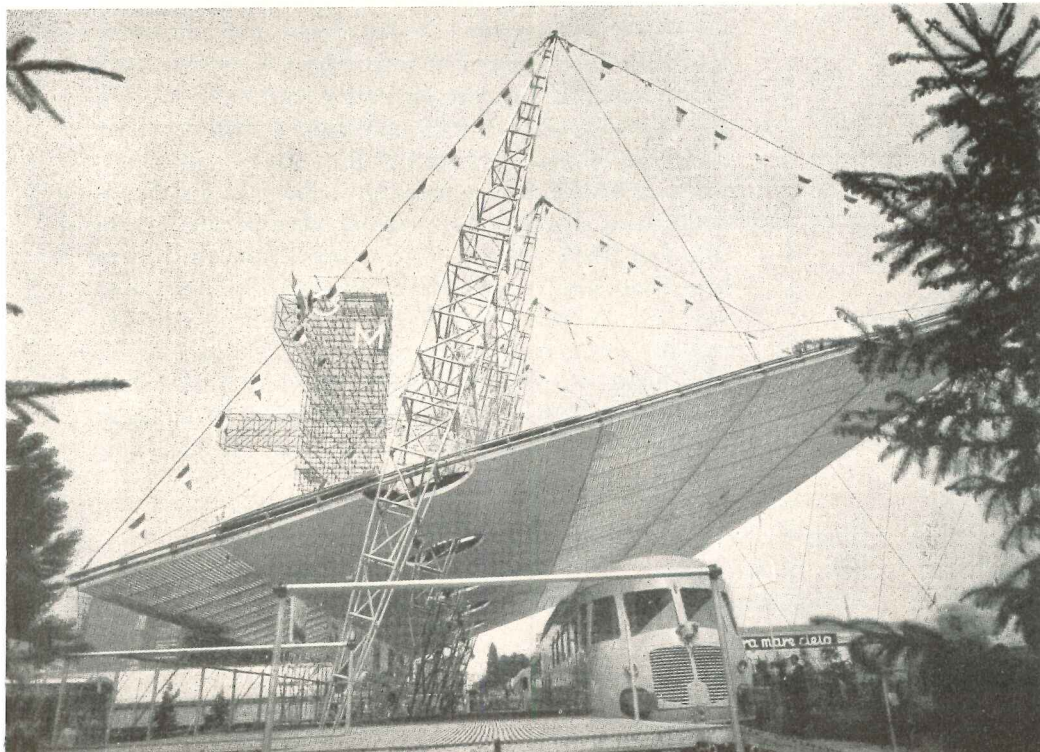

129





The White House as it looks today from Pennsylvania Avenue; present rebuilding program will preserve this facade

## REBUILDING THE WHITE HOUSE

By Frederick Gutheim

NEWS that the White House was falling down, that it had grave structural defects, was a fire trap, would violate the building codes in any sizable American city, and would have to be reconstructed at a cost of somewhat more than \$5,000,000, was received by most architects with incredulity. How does a building that has seen a century and a half of service so suddenly fall into disrepair? Why does it cost so much to reconstruct it when a replica could be built for half that sum? What, perhaps most of all, is to be done to the building that would involve such an expenditure?

The ills to which the White House has fallen heir, and which must now be remedied are of two sorts, those of structure and those of function.

As to the structure, the chief difficulty arises from interior masonry partition walls which, in James Hoban's original design, were not load bearing. As the building underwent successive remodelings to accommodate more people in the attic — a process that culminated in 1927 with new steel roof trusses — the partition walls came to support a large part of the weight of the new roof. Unluckily the brick partition walls, only 9 in. wide at the second floor, on which this weight of 90 tons rests, had no footings. (The original exterior walls, supporting the original roof load, did.) The result is that the now bearing partition walls have slowly been pressed into the ground. As they have sunk, the partition walls have also pulled away from the exterior walls of the building. In some places the settlement has left gaps 2 or 3 ins. wide. Bureau of Standards engineers have made careful measurements of the interior wall movement, and their final conclusion is that the building is undergoing a progressive collapse, slow at the present time but likely to accelerate at any moment. Failure here would lead to a general collapse of the entire structure. This is the chief reason the President, his family, and his entourage have vacated the building and are now living across Pennsylvania Avenue in the Blair House, a residence remodeled by the State Department several years ago for the reception of distinguished



Plaster has been removed from one of the brick partitions to show settling cracks; these walls have no footings, were never intended to bear present loads

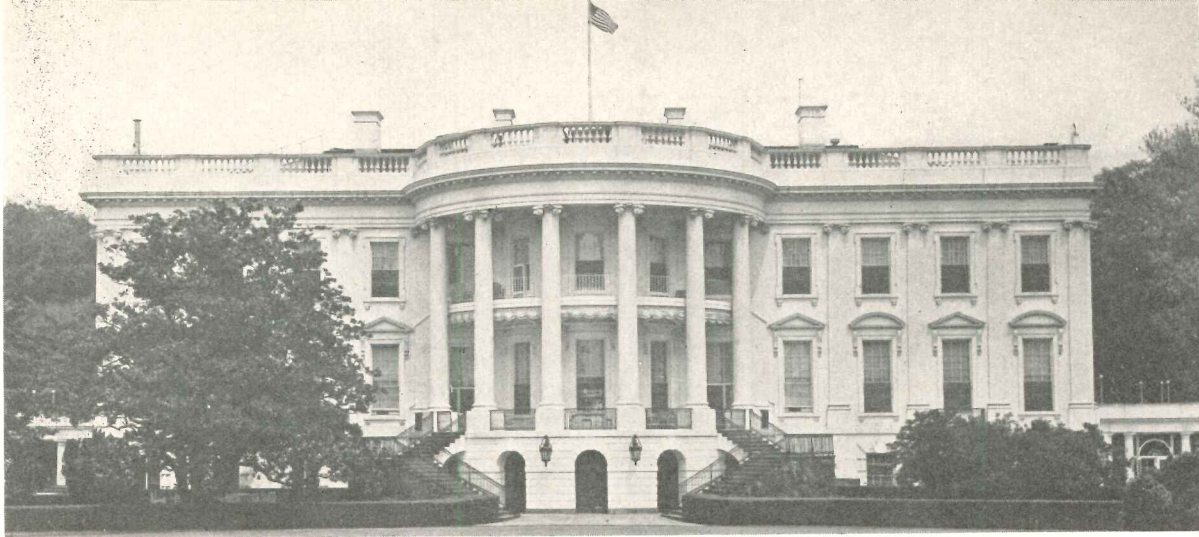

*Almost every president has added to or remodelled the White House; President Truman added his famous balcony*

visitors of state. It is unlikely the White House can be reoccupied for two to three years, for the work of reconstruction will be slow as well as costly.

The second major structural factor is the result of the passion for "improvements" that marched steadily with the 19th and 20th centuries, until today there is scarcely a beam in the entire building that has not been bored or cut through dozens of times to accommodate water and sewer pipes, gas pipes, heating pipes, electric and telephone wires, automatic fire alarm and guard signal systems, elevators, a fire extinguishing system, and other mechanical innovations. In the very structure of the building itself (for propriety and taste would not countenance it exposed), generations of architects and builders have concealed the complete mechanical equipment of a modern office building, none of which was provided or even contemplated by the original builders.

The slow murder of the original building led finally to the vibrating floors, the shaking chandeliers, wall cracks, and the dramatic collapse of the floor in Miss Margaret Truman's second floor sitting room, when a beam split under some unexpected load and one piece of it punctured the delicately groined ceiling in the private family dining room below.

Other less important and less extensive structural defects have been disclosed, among more important of which is the loosening of the heavy ornamental plaster ceiling in the East Room. In addition, the usual accumulation of ancient electrical wiring not encased in conduits, and other defects in construction now barred by building codes in most cities, were unearthed. This is presumably what Public Buildings Commissioner William E. Reynolds had in mind when he said the building would not pass the building codes.

To ascertain the state of the building, foundations — or the lack of them — have been uncovered, floors have been taken up, and plaster removed from walls and ceilings. In this investigation, the first thoroughgoing structural exploration in its entire history, experts of the Federal Works Agency, the Public Buildings Administration, the National Park Service, and the Bureau of Standards have participated. Up to now the White House has been redecorated, remodeled, or mechanically improved, but so far as the structure

itself was concerned, it was ignored or patched up with tie rods and turnbuckles.

Before going on to other problems presented by the building, it seems worth while to mention two facts that have emerged from the extensive survey. The first is that had no extensive changes been made in the building, it would have remained wholly satisfactory to this day. The original design and construction were first rate, and although one finds here and there the usual anomalies of all old building — stones mixed indiscriminately with brick construction, lime mortar, and the rest — it has stood the test of time remarkably well. Unlike many 18th century buildings, in England particularly, that were so poorly built they had to be torn down, the White House shows that our ancestors built well.

The second is that had the functions of the building not multiplied beyond the most remote conception of its original designers, bringing far heavier floor loads, new demands for entrances and exits, larger attendances at state dinners and official receptions, a greater retinue of servants, household and domestic attendants, private and official secretaries, and the like, the structural problems themselves would be far less acute.

The White House, in short, is neither worn out nor used up; it is overloaded. One does not expect a residential building to stand up to the kind of traffic expected in a railroad terminal. That is why structural considerations alone are an inadequate measure of the reconstruction about to be undertaken. Some decisions on the functions of the building come first.

The President's House — to give the building its first and best name — was conceived as a residence for our chief of state. In contrast to the palaces of European rulers in 1792, when Hoban won his \$500 prize in a competition for the building's design (and embarked upon a career as a public buildings designer that in-

Douglas William Orr, former president of the American Institute of Architects, is one of two recently named by President Truman as public members of the commission which will supervise the rebuilding of the White House. The other public member is Richard Erwin Dougherty, former president of the American Society of Civil Engineers. Both have already served as members of the President's Advisory Committee on Safety of the White House.

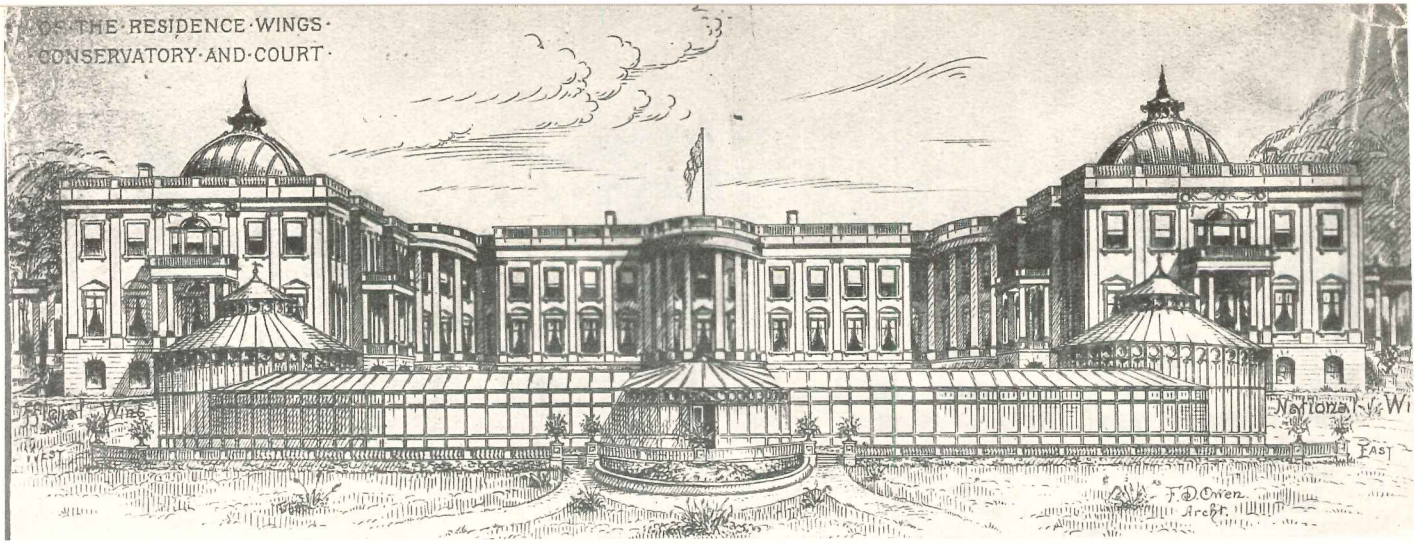

Scheme for "improving" the White House, presented to President McKinley in 1899; A.I.A. opposition killed it

cluded the reconstruction of the White House after the British had burned it in 1814) the building was a modest one. Here, it was assumed, the chief of a democratic state would live, and here he would entertain on an appropriate scale befitting the dignity of the nation. Abigail Adams, the first "first lady" to occupy the building, remarked in astringent language "it is an establishment well proportioned to the President's salary." But it did express a national ideal.

At the point in 1800 when Mrs. Adams was able to claim six of the 30 rooms in the President's House (builders still occupied the rest) and begin complaining that the plaster was not dry and the paint was still wet, the Washington bureaucracy consisted of 128 persons and the nation had a population of about three million. But in less than a hundred years, guests attending obligatory receptions at the White House came down with

pneumonia as the result of standing in queues in the snow to enter the building, and temporary wooden stairs were erected to provide an exit from the East Room through one of the windows.

Cabinet meetings that began on the second floor of the White House adjoining the President's oval study — the room now leading to Mr. Truman's famous balcony — by the time of Lincoln's war administration had thoroughly invaded the President's domestic sanctuary. The presidents and their families never really succeeded in recapturing their living space after the invasion during the civil war days, when telegraphers, secretaries, cabinet chiefs, functionaries, and even office and commission-seekers made free with the place. They stirred restlessly and demanded stained glass screens from Tiffany, or fumed oak wainscot in the prevailing mode, but they never succeeded in getting space and privacy. The cabinet continued to meet on the second floor of the White House until Theodore Roosevelt called a halt, and changed the scene to the new White House executive office wing.

The emancipation of the White House from this intolerable jumble of domestic and official functions was achieved in the Roosevelt administration by the simple device of removing all the office work to a separate wing erected at the end of the west colonnade. That liberated the second floor of the White House itself. The first was largely dedicated to the Red, Green, and Blue Rooms, the East Room, and the Dining Room — all reserved for state occasions. The basement (which to the south is wholly above ground) became the stronghold of cooks, gardeners, carpenters, doctors, dentists, librarians, and anyone else who was able to find a place in the President's household and hang onto it.

The Roosevelt reform, accomplished under the direction of Charles Follen McKim, was decisive. It estab-

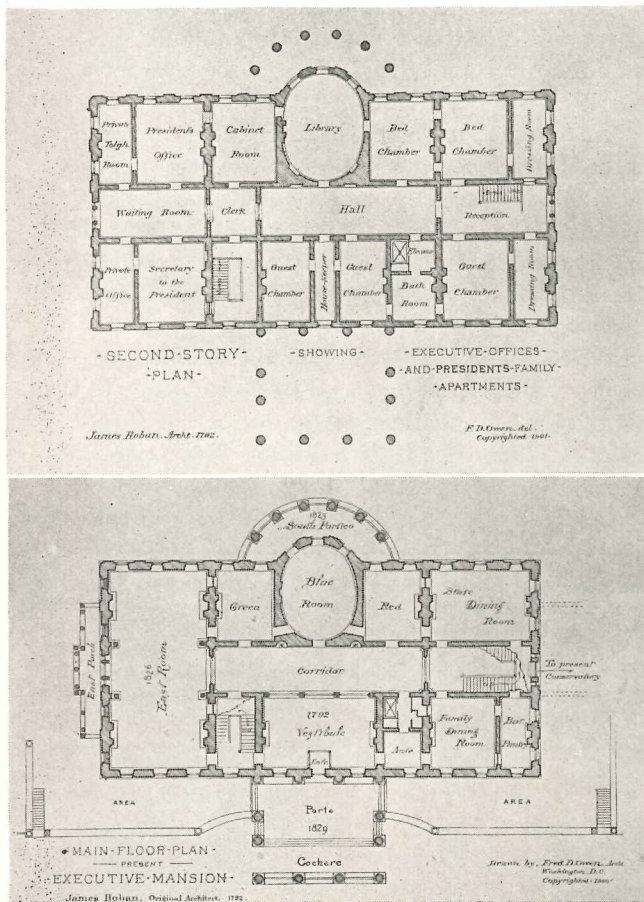

Floor plans of the White House, circa 1900, as drawn by F. D. Owen, architect for the enlarging scheme shown above; dates show when various rooms were added

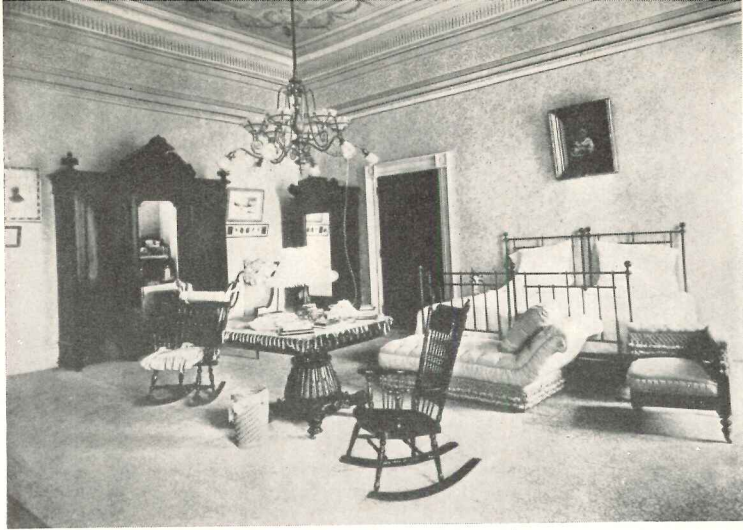

President McKinley's bedroom

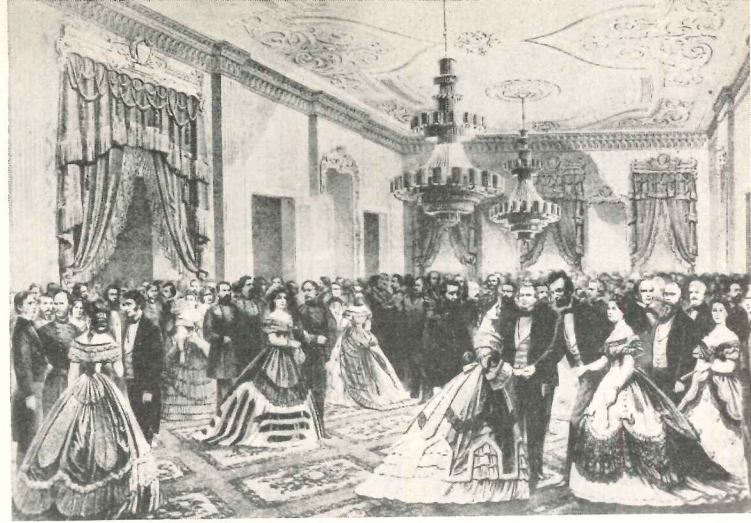

A Lincoln reception in the East Room

lished for good the residential character of the White House, which had been menaced only a few years earlier by President McKinley, who sponsored a plan conceived by Colonel Theodore Bingham — an atrocity that can only be described as miniature versions of the then-popular Library of Congress, mounted on top of two enormous wings that would have obliterated the original building.

That President Roosevelt was decidedly aware of what he was doing with the McKim plan is amply confirmed by his famous letter to the American Institute of Architects, and the determination of that body ever since to maintain the delicate balance between a residence and a public building that McKim had given it.

Every proposed change in the White House since has been motivated chiefly by a desire to obtain more space for the expanding functions of the executive office. The

*(Continued on page 182)*



Scaffolding supports the sagging ceiling of the famous East Room. Upper view shows that this ceiling has sagged six inches. Beneath the scaffolding in the lower view (April 6) are C. W. Barber, chief structural engineer, PBA, and Lorenzo S. Winslow, Architect of the White House

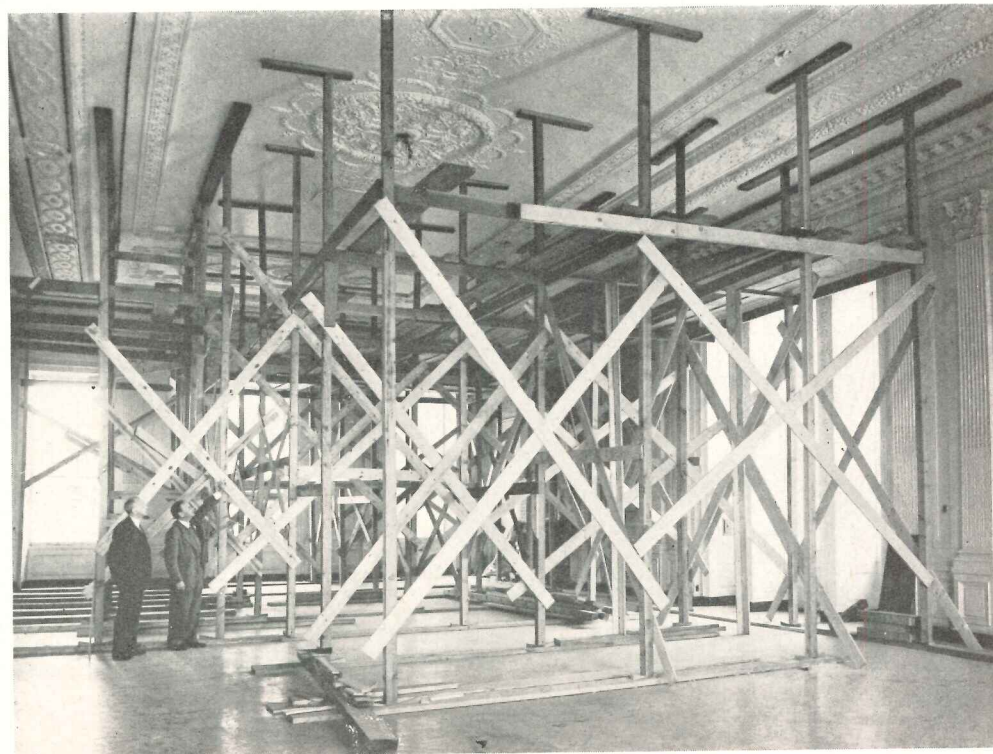

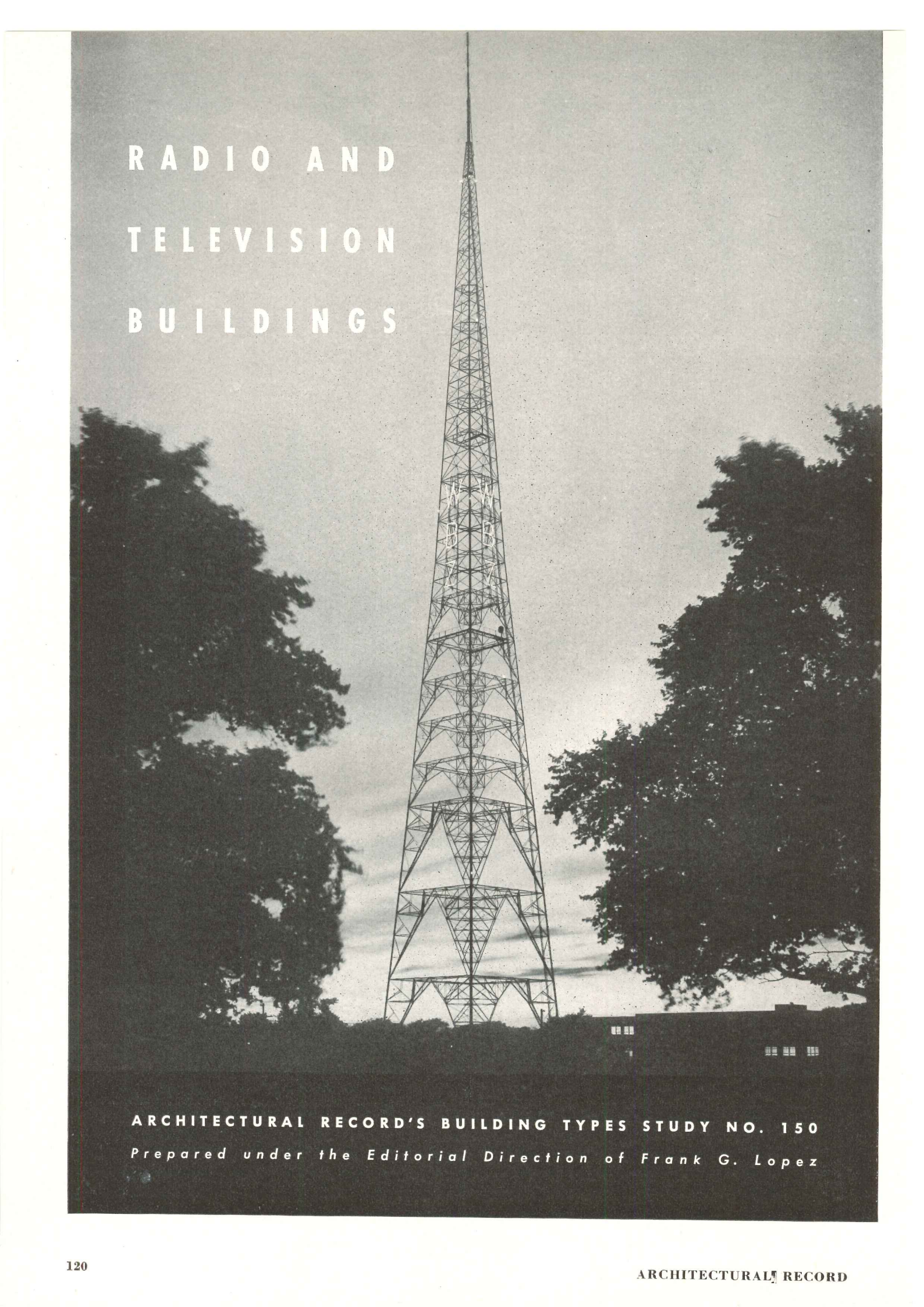

RADIO AND  
TELEVISION  
BUILDINGS

ARCHITECTURAL RECORD'S BUILDING TYPES STUDY NO. 150  
*Prepared under the Editorial Direction of Frank G. Lopez*



THERE are just enough similarities between radio and television broadcasting to confuse the building designer. However, radio is concerned with reproducing *sound*, while TV's greatest problem, not thoroughly licked though commercially quite feasible, is satisfactory *visual* reproduction. Visual broadcasting entails not only photogenic scenes and performers; to create its illusion TV has borrowed techniques and performers from the legitimate theater and the movies; in many studios properties are literally borrowed from the neighborhood retail store, after the fashion of an amateur dramatic club. Radio has borrowed performers from the theater and, often, the audience. Radio requires a studio sized and acoustically treated to suit the performance, containing a few props, sound effects, microphones, and enough light for reading scripts. In the 'live' studio TV requires a blaze of light, stage sets, many props, usually three cameras per show, all movable on dollies; mikes on booms, also mounted on dollies (these can't appear on the receiver screen); and a host of performers and production personnel: actors, camera and mike operators, dolly pullers, electricians, property men, stagehands, and assistant directors. Cameras, mikes, and lights demand complex wiring which usually covers the floor like a mass of snakes; no better system has been found; changing the camera cable's length causes serious technical difficulty.

Congestion of TV equipment, wiring, and personnel is so great that a studio audience is tolerated only when it is indispensable to a show. The program director in charge of a production works from the glass-walled control booth, supervising the performance and numerous control technicians simultaneously, and talking to the studio staff over an intercommunication system. The sponsor is usually in a separate booth to minimize interference with the broadcast.

Partly because technical changes are foreseen and partly due to complexity of broadcasting channel allocation, the Federal Communications Commission has granted no TV licenses in recent months. Impatient though broadcasters are with this 'freeze,' in the long run it should save both them and the public money

and confusion. By early summer the Commission reportedly expects to decide on TV allocations in the VHF (very high frequency) channels; by late summer the freeze may be lifted. This would mean rapidly accelerated construction of TV facilities this fall. UHF (ultra-high frequency) broadcasting, a rumored possibility, depends upon development of suitable power. The following figures, obtained from FCC, tell the story as of March 31, 1949:

TELEVISION STATIONS IN THE U. S. A.	RADIO STATIONS, FM
Now operating, fully licensed . . . . .7	Now on the air . . . . .724
Operating	Authorized but not yet op't'g . . . 199
Special Temporary Authority . . .52	Total now authorized . . . . .923
Total now operating . . . . .59	
Authorized but not yet op't'g . . . . .62	RADIO STATIONS, AM
Total now authorized . . . . .121	Now on the air . . . . .1974
License applications pending . . .323	Authorized but not yet op't'g . . .175
Total authorized & pending 444	Total now authorized . . . . .2149

Considering its relative youth, licensing difficulties, high building costs, fantastic equipment cost, and the frequent introduction of substantially improved equipment natural in so young an industry, the TV situation is phenomenal. Color television (for which two systems — one mechanical, one electronic — are understood to be now feasible) can further complicate matters.

Preoccupation with technicalities of visual broadcasting has been accompanied by a low level of intrinsic quality of TV programs. Coincidentally, the purely architectural worth of many TV buildings also parallels program quality; the same factors contribute to this condition and, if only for the promotion value of a good building, the same dependence upon public opinion may bring improvement.

Sky-high equipment cost, newness, and experimentation lead to much remodeling of buildings for TV, particularly for big-city studios where network programs originate and where land and building costs are highest. Architectural opportunities are somewhat limited in the case of these large studios, but medium-sized studios offer many. By far the greatest number of TV stations now contemplated is medium-sized, each containing a

George W. Warnecke & Co., courtesy Monitor Roofing Co

Left, transmitter tower, Station WBZ, Boston, Mass.; 649 ft. tall, it is surmounted by a three-section turnstile TV antenna which is supported by a two-section pylon FM antenna. Combined antennae are 76 ft. long, weigh 7442 lb., atop a heavy-duty steel tower which expands from a 29-in. square top to a 75-ft. square base carried on concrete foundations. Contrast the elegance of this competently engineered design with the typical hodge-podge of receiving antennae on the roof of a New York apartment house (right)

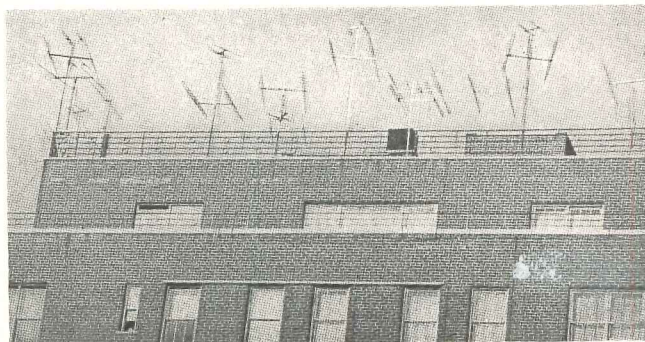

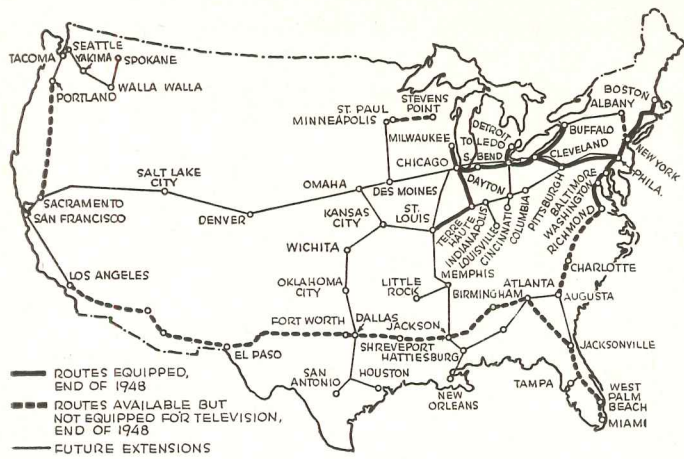

Above left, routes of coaxial cables and microwave relay facilities for television networks

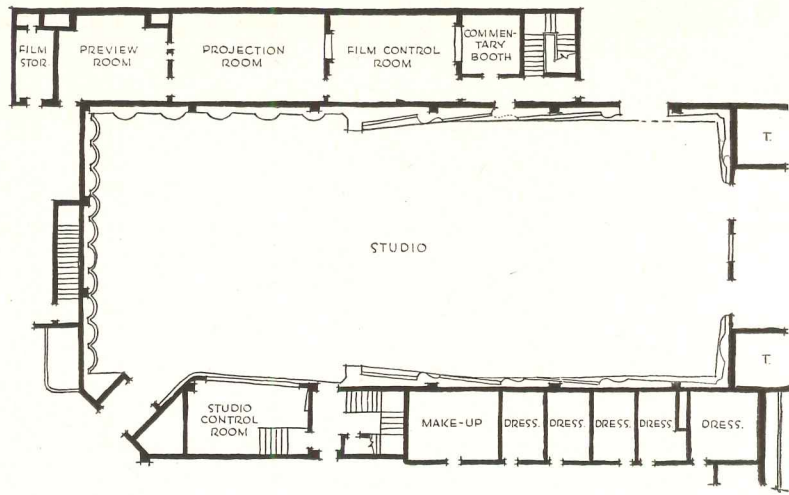

Three ways of providing for television: above, NBC's Studio F, Hollywood, Calif., a converted radio studio; below, WFIL-TV, Philadelphia Inquirer station, built new, will also televise from the adjacent Philadelphia Arena and has remote transmitter in the Widener Building; bottom of page, part plan of WCBS-TV's New York studios in remodeled office space in the top of Grand Central Station

relatively small studio, mobile facilities, rebroadcasting facilities, control and transmission equipment, and offices. After these principal network links are established small studios will come along. Whether a small station can be designed to grow efficiently is an unresolved question.

For all the technicality of TV problems there is sound consulting advice available in the form of lighting, air conditioning, and sound control experts. Coordination of all types of equipment, and of spaces and techniques both borrowed and inherent in TV, is an architectural problem about which the TV station manager has much to say. He has opinions on the staggering circulation problem. He is an authority as well as a client; his decisions carry much weight, which may account for some makeshifts — even mistakes — which characterize many TV buildings. Certainly those stations in the design of which good architects have been employed demonstrate the value of competent architectural effort.

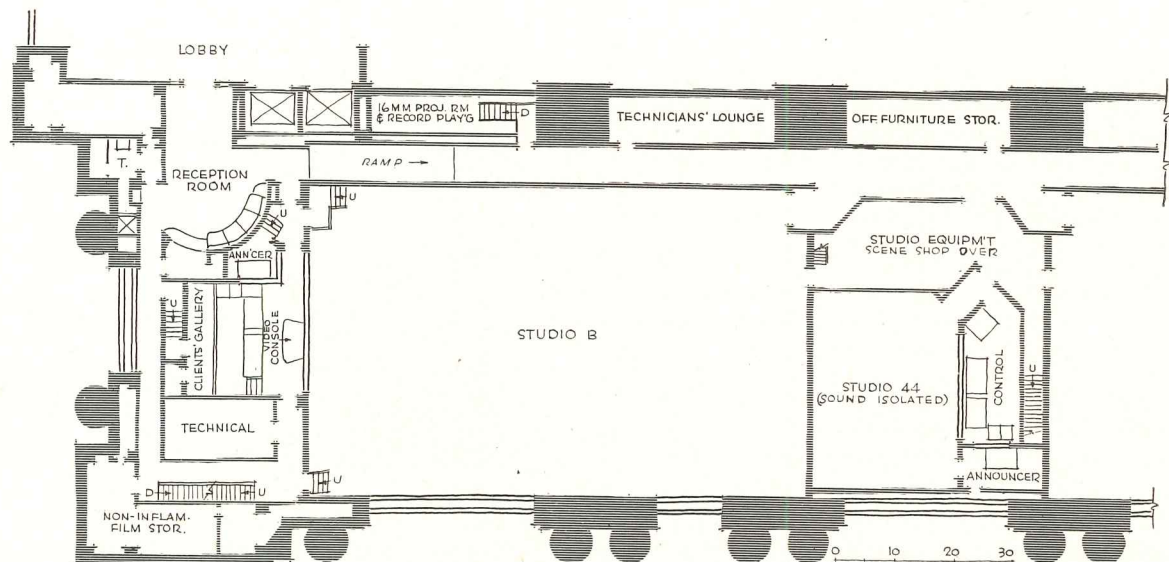
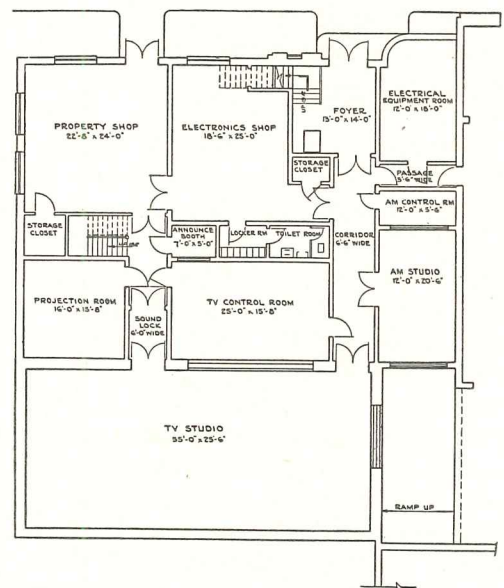

# DESIGN OF TELEVISION STATIONS

By J. P. Allinson

THE financial importance of television buildings is indicated not only by their increasing number but also by the high cost of their equipment; telecasting equipment, air conditioning, lighting and sound control equipment for the 59 stations now licensed runs well up into the hundreds of thousands of dollars. Add the expense of actual construction and the dollar outlay becomes truly impressive. Whatever the opinion of TV as a cultural medium (and a few recent programs have had critical acclaim), the 2,000,000 estimated viewers of the last Presidential election constitute an audience which cannot be ignored. The industry generally is in a developmental stage — its youth, scarcity of suitable space, and astronomical costs not only complicate the design problem but also make it necessary to limit this article to a survey of ideas in the field at the moment.

## TYPES OF STATIONS

**Network Originating Studios** Many of the networks (ABC, CBS, NBC, Mutual, Dumont, and Don Lee) have recently completed or are about to open new plants. Several have tremendous expansion plans; most consider their present facilities experimental. The large central station in which network programs originate is most complex, likely to be scattered among several floors or even several buildings in the downtown part of a large city. Often it is a remodeling job, designed by the network's architectural staff. The typical large station contains numerous studios, each with a control booth, central control facilities, and a full complement of technical, production, and administrative areas. Such close scheduling of TV broadcasts is necessary, in order to make maximum use of the costly space and equipment, that *circulation* assumes paramount importance, and

The author and the editors wish to thank the following individuals and organizations for their assistance in compiling the information contained in this Building Types Study, for permission to reproduce drawings and photographs, and for their help in checking preliminary copy.

Television Networks: ABC, CBS, Don Lee-Mutual, Dumont, NBC and their engineering and publicity departments; TV Stations KNBH, WABD, WPIX, WRGB; Paul Adanti, General Manager, WHEN; L. E. Littlejohn, Chief Engineer, WFIL-TV; Kliegl Bros. Lighting; Television Associates Inc.; Anemostat Corp. of America; the editors of "Communications", "Electronics", "Televiser Monthly", and of General Electric's "Television Show Business" and RCA's "Broadcast News" and "RCA Review;" and J. W. Eriksen, Engineer, The Austin Co. Organization chart, top right, appears courtesy NBC.

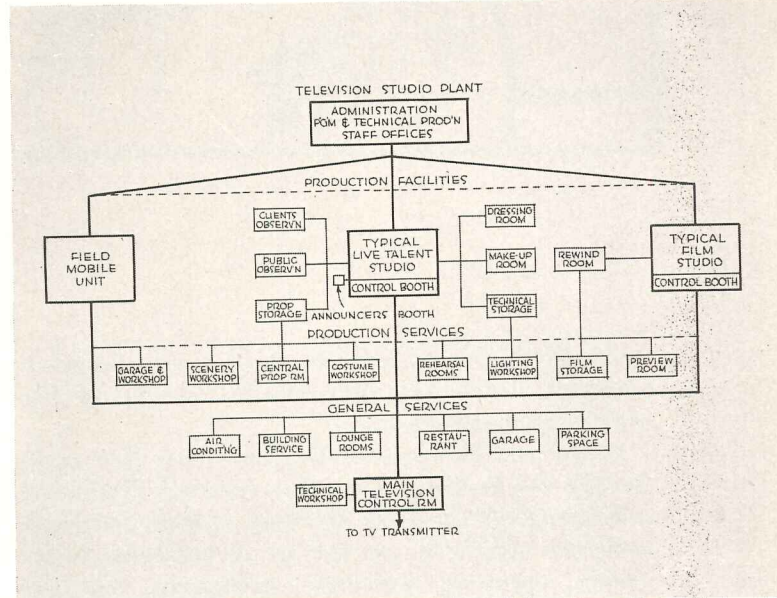

## CIRCULATION PROBLEM IN A TELEVISION STUDIO

### FIVE KINDS OF PEOPLE

1. "TALENT": ACTORS, ANNOUNCERS, ETC.  
DIRECT ACCESS TO STUDIO, DRESSING ROOMS, ETC.
2. TECHNICIANS: DIRECTORS; CAMERA, MIKE, LIGHTING MEN, PRODUCTION; ETC.  
DIRECT ACCESS TO STUDIO, CONTROL ROOM, TRANSMITTER, SHOPS.
3. SPONSORS.  
ACCESS TO SPONSORS' SPACE, ADMINISTRATIVE SPACE ONLY.
4. PUBLIC, INCLUDING STUDIO AUDIENCE.  
ACCESS TO PUBLIC LOBBY ONLY, EXCEPT FOR SHOWS REQUIRING AUDIENCE.
5. ADMINISTRATIVE AND OFFICE PERSONNEL.  
ONLY KEY PERSONNEL REQUIRE ACCESS TO SPACES OTHER THAN OFFICES AND PUBLIC LOBBY.

### THREE KINDS OF THINGS

1. SCENERY AND PROPS STORED ON PREMISES.  
DIRECT ACCESS BETWEEN STORAGE, SHOPS, AND STUDIO.
2. PROPS AND SCENERY NOT STORED ON PREMISES.  
DIRECT ACCESS BETWEEN TRUCK LOADING, TEMPORARY STORAGE (STAGING) AREA, AND STUDIO.
3. TECHNICAL EQUIPMENT: CAMERAS, MIKES, LIGHTS, ETC.; PERHAPS MOBILE TRANSMITTER.  
ACCESS BETWEEN TECHNICAL SHOPS, GARAGE, AND STUDIO.

*The  
Television  
Production*

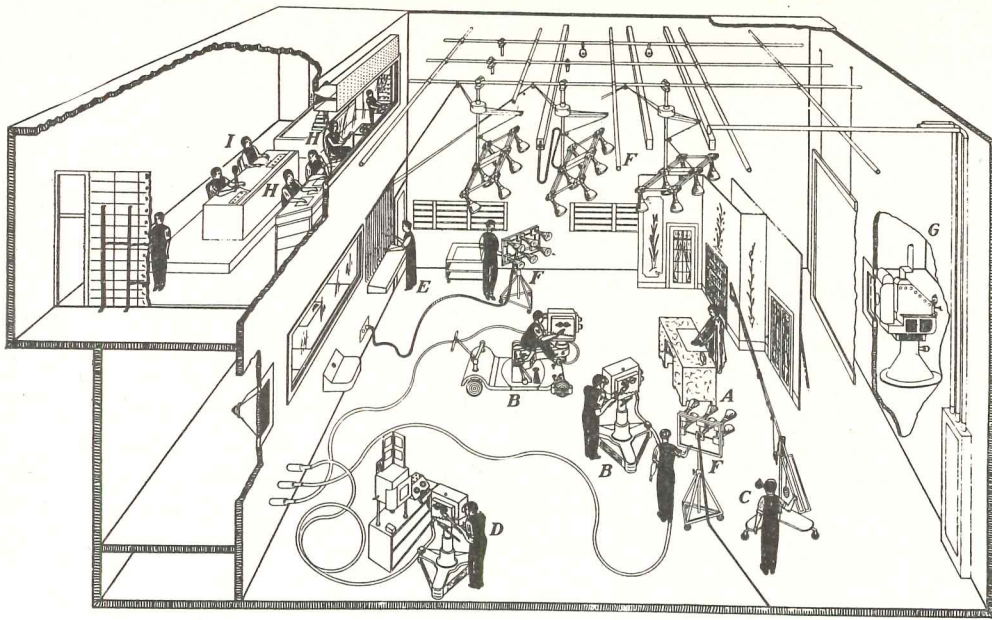

1.

Requirements for live-talent studio; sketch by Engineering Dept., NBC. A, scene being televised; B, cameras; C, microphone boom; D, camera picking up titles and video effects; E, lighting controls; F, lights (only a few shown) adjusted from E; G, slide projector for rear projection of scenery; H, audio and video control; I, program direction

the *traffic department* becomes the nerve center where schedules, distribution of programs through the network, etc., are handled.

People and things (see diagram) must flow easily through the building; control is essential. Executives and managerial personnel, sponsors, visitors, and studio audiences ordinarily use one set of entrances to the station; operating personnel — technicians and production staff — another; talent — actors, performers — a third. The diagram indicates the necessity for keeping the various kinds of traffic separate. In a one-story building, production shops and storage rooms might be on the opposite side from spaces reserved for talent, who should be able to enter directly from the street or parking space to their dressing rooms. Costume storage, make-up and artists' lounge rooms should be adjacent; if on another floor, a quick-change room should be pro-

vided near the studio. Ample rehearsal space is needed.

Production spaces are like those in the legitimate theater, but have to be larger and more accessible because the TV show is put on for one performance only, not for a long run, which means storage for many types of properties and scenery and delivery space for many more; carpentry and paint shops for the continuous making or revamping of scenery for new productions, and wide corridors, sound locks, doors, etc., for moving large units expeditiously from shop or shipping entrance to studio. Production personnel includes stagehands, prop men, etc., who have no occasion to enter talent's quarters but must have direct access to the studio. Technicians include those who work in the studio itself — camera and microphone operators and lighting men — and those who man the control rooms — video and audio operators, etc. — both of whom have contact

2. Live studio, KGO-TV (ABC) in San Francisco, view from control room showing sound-deadened walls, ceiling; portable and ceiling lights, air ducts, 3 cameras; at bottom, monitors as seen by video technicians. 3. Proposed alteration of Civic Theater, Chicago, for ABC telecasts. 4. Daytime studio from audience seating, WABD (Dumont), New York. 5. Making a telecast, KNBH (NBC), Hollywood

2

3

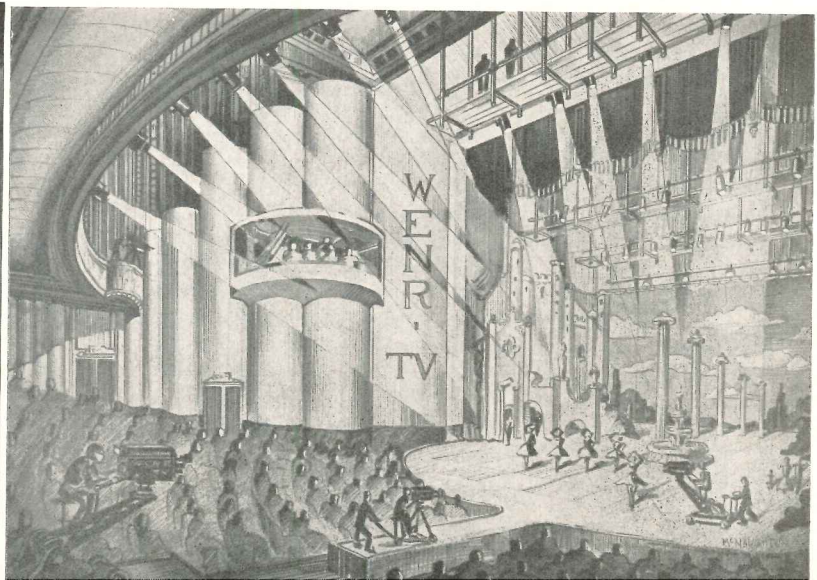
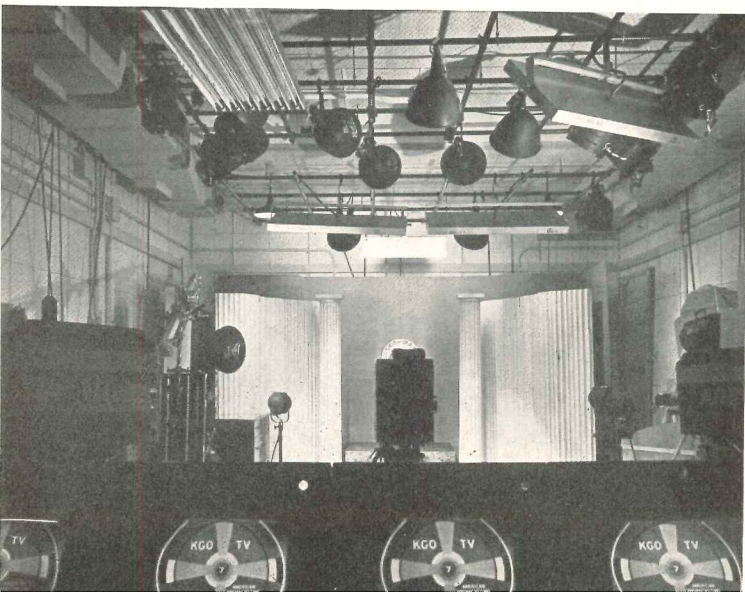

with the performers in the studio only. Technical spaces include not only the studio and master control rooms but also the transmitter room, equipment spaces and shops for working on equipment. It is convenient to have the garage for the mobile truck transmitter accessible to the technical shops. The entire production is supervised by a director (who works from the studio control room), one or more assistants (who work in the studio) and a script girl who is constantly at the director's elbow. The director talks to his assistants, lighting and production chiefs, and camera and microphone men over some type of intercom system: pocket radio, wired phone headsets, in some cases a low-volume loudspeaker.

In most studios audiences are not admitted, because they are the source of unwanted noise and because the congestion of equipment and personnel in the studio is so great that an audience cannot be allowed. Only in a few, and these mostly of the theater type for shows which demand audiences, is the public admitted. TV cameras require a great deal of space in which to maneuver — they are mounted on dollies which are pulled by men — and this also restricts the amount of space which can be given over to an audience. Audience circulation through the building must be very closely controlled. Many station operators would like to place similar limitations on sponsors as well, but this is rather difficult to achieve. Usually the sponsor has a booth completely separated from the studio and control room, with a glass wall into the studio for direct observation. CBS, in its new Grand Central studios in New York, places the sponsors in the control room itself, a practice which makes most program directors shudder. Regulations governing places of assembly must be respected.

Films, slides, commercials, etc., are dubbed into the TV program as it goes over the air from a telecine room, and announcers have a small studio; these are all grouped around the control room. In a large station, much dubbing in may be controlled from the master

control room; it may also be done from the studio control. The transmitter and tower may be at the station or remote.

**Very Small Stations** At the opposite end of the TV building scale is the small local station for receiving network programs and making spot announcements, etc. This type is likely to be located at the ideal transmitter site, which may not be "downtown." Space requirements include a room for telecasting equipment and transmission, for network pick-up equipment, etc.; a small announce booth, telecine space and film storage. Personnel is usually limited; commercial and administrative offices are combined; minimum toilet facilities are provided. There may be a small room for costuming, make-up, etc., for the rare occasion when the local mayor will make a personal appearance on TV.

If there is any likelihood of televising local sports or other events, the station will have a mobile transmitter truck, which will require a garage. Often this space is so designed that the truck can drive virtually into the studio itself; on occasion the truck control equipment might be used instead of a studio control console (there is a difference of opinion on this practice). More common practice is to install, when the station is located at the transmitter site, a microwave receiver to pick up signals from the mobile transmitter. Switching between all the different types of programs is handled by the combination transmitter and master-control operator.

If the station transmitter has a downtown location, a small studio is probably essential because the possibility of telecasting simple studio shows is increased. Another variation, which interests a great many TV operators, has an out-of-town transmitter site and, downtown, a small plant containing film and slide projection facilities, small studio, announce booth, and control room which serves as master control, coordinating all program sources. The plant can be linked to the

4

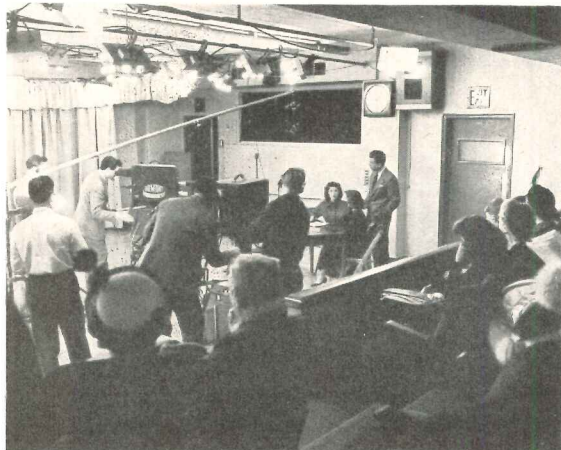

5



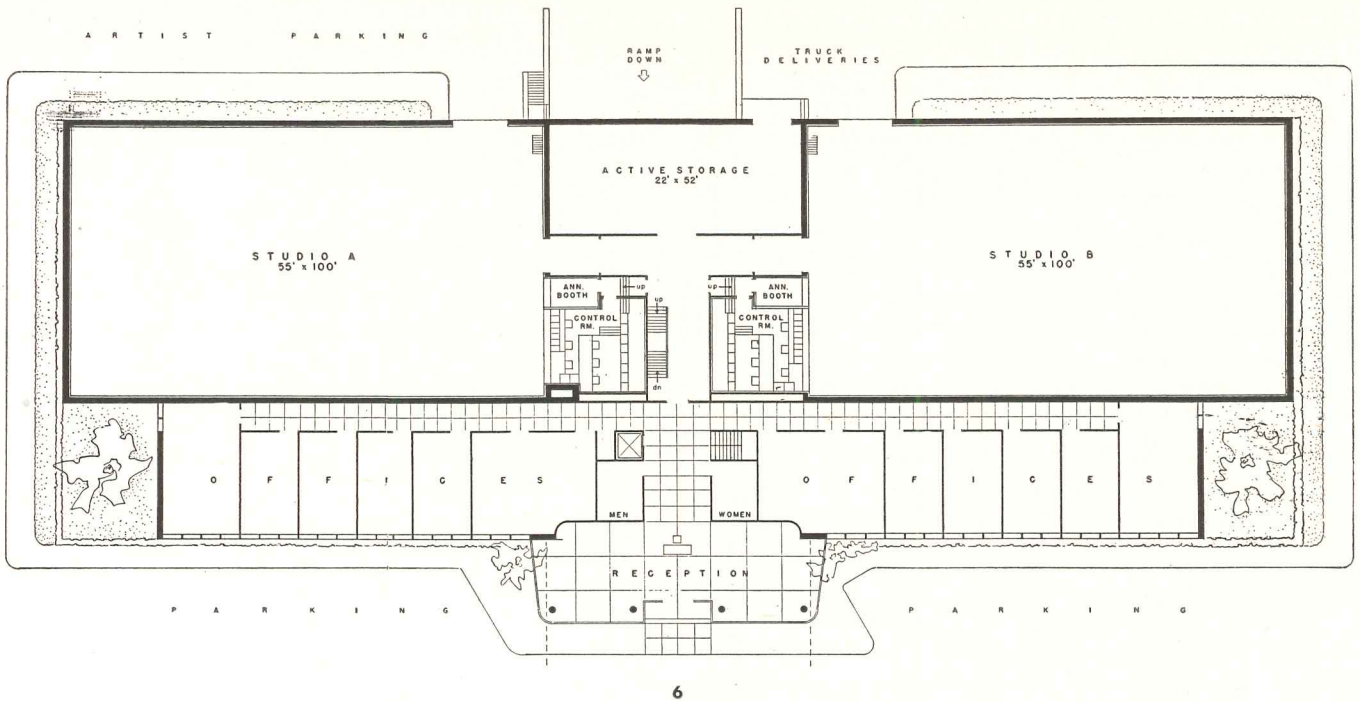

transmitter by microwave; mobile signals can be received and coordinated at the downtown plant or at the transmitter. All these variations on the small station assume a tie-in to one or more of the networks; cost of producing a "live talent" show is prohibitive for the small operator. As the accompanying map shows, coaxial cables and microwave relays essential for direct distribution of network programs are not likely to cover the entire country as rapidly as the demand for TV stations requires. The industry's answer to this dilemma is *kinescope recording*, or precision photography of actual TV programs. The technical difficulties are being solved, and kinescope promises to become a major source of network-quality programs.

**Intermediate Stations** Between the two types outlined — definitions here are arbitrary, assumed solely for convenience — lies a third principal type. It may be considered an expansion of the small station; it incorporates many features of the key network station, but is not considered adequate for full-scale network

10. Studio suggested by William Foss, TV consultant, to use mobile unit controls at first, to which more equipment and another studio may be added efficiently

program origination. Although this type may contain more than one "live" studio, it can be planned quite successfully for a single, fairly large studio and control room around which are grouped announce booth, telecine room, network receiving equipment and transmitter room; from the one control room all master switching between studio, film, and remote programs can also be handled. The distinction between this and some variations on the small studio lies principally in technical facilities for programming. The studio itself is ordinarily larger to accommodate the desired 3 image orthicon TV cameras and mike on a telescoping boom, but otherwise total space requirements are little greater.

The telecine room here will probably contain two "multiplexers," or angular mirror setups for film and slide projectors which make possible the use of a single stationary TV camera (rather than a moving TV camera to be shuttled back and forth between movie projectors, which is common in smaller studios). Facilities for film processing, airing and editing should also be provided. It should be possible to add a second studio efficiently in the future; this may be a rehearsal room at the beginning. An eventual master control room and more office space should also be envisioned at the outset, and some provision must be made for the ultimate wiring system.

Even for the minimum, it is often advisable to plan for two studios, either both the same size or one fairly large — say 25 or 30 by 40 feet — and one small, for one-set performances. Adding the master control room eases coordination of technical facilities, permits operation by one man during long network periods, permits equipment repairs and maintenance without disturbing facilities; and one man can keep continuous watch over equipment performance. The projection room is best located next the master control room; when two studios are planned, a satisfactory working arrangement is to have this pair of spaces between the studios, with the studio control rooms above.

10

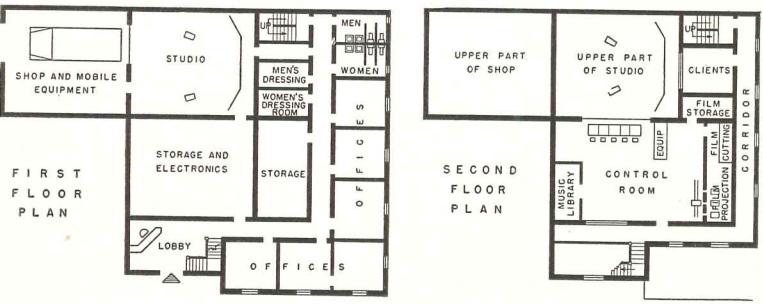

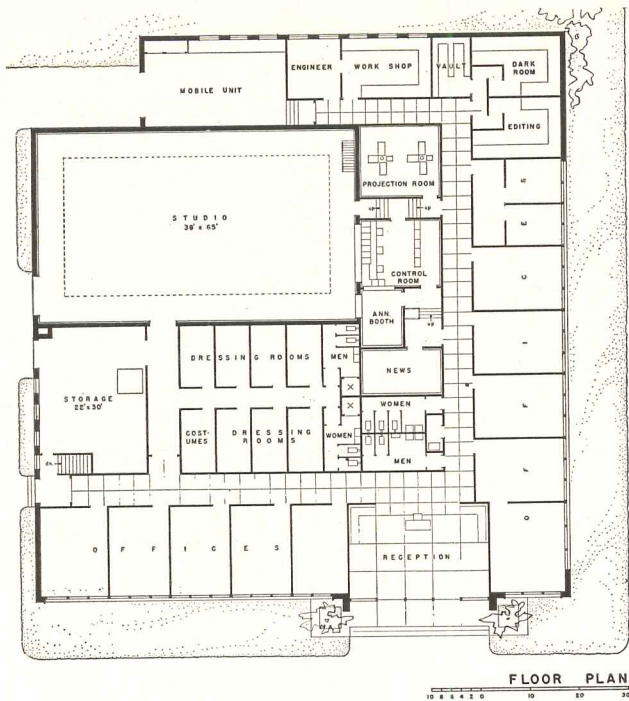

7

### BUILDING DESIGN CONSIDERATIONS

Whatever the station size, rigid economy and compactness are essential. Equipment cannot be skimped, but little can be spent on impressive architecture and even such considerations as noise control and acoustics are handled inexpensively. Compactness also helps the plant to run smoothly, reducing operating costs. Many of the schemes illustrated are admittedly faulty because many existing studios are remodeling jobs or revamped radio studios, in which space and structure impose serious limitations.

The building designer will cooperate with the station manager or engineer, network advisors to affiliates, the video engineer, and probably a TV consultant. He will learn that a TV station requires three or four times as

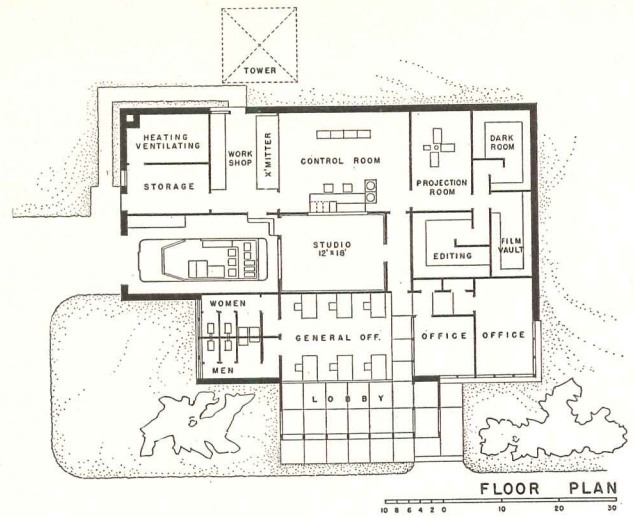

8

much space as a comparable radio station. Space estimates are difficult to make, but NBC engineers, for instance, suggest that a single live-talent studio entails five times the studio area for auxiliary spaces; that for a station containing three live studios the proportion is reduced to three times studio area. Production methods are almost certain to change, so flexibility of the original space and provision for expansion are important. TV plants have been developed both horizontally (all principal areas on one main floor) and vertically (multi-story). The horizontal plant offers production advantages, is easily expanded, but requires much land. Multi-story schemes may cost less initially but are difficult to expand; when enlarged, the plant's facilities may be scattered, leading to difficulty — and consequent high cost — of operation.

6, 7, 8. Floor plans of typical very large, intermediate, and small stations developed by Rene Brugnoli, Archt., and Ben Adler, TV Consultant. 6 has rehearsal rooms, building equipment, etc., in basement; master control, equipment, etc., on second floor. 7 has scene shops etc., under storage and dressing rooms, elevator to storage space. 8 envisages use of mobile equipment for control. 9. Plan, WXEL, station now under construction, Parma, Ohio; Rene Brugnoli, Archt. Note resemblance to typical schemes; also close relation between control and transmitter space. Studio wall opens up for supervision of telecasts from adjacent sports field

9

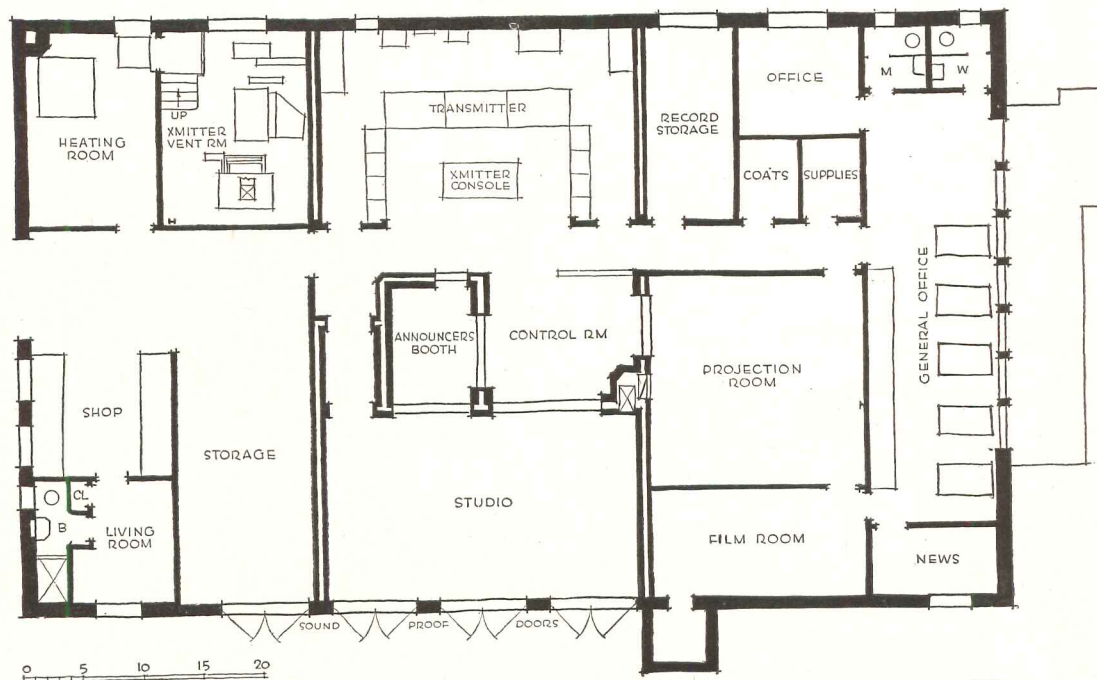

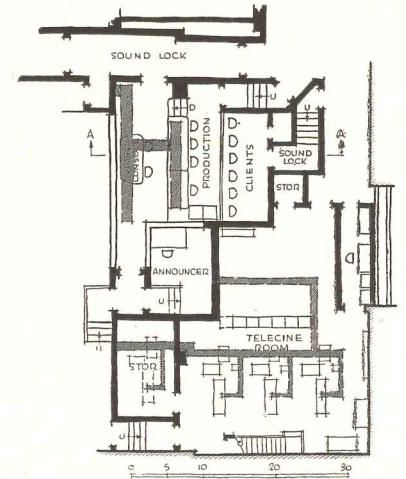
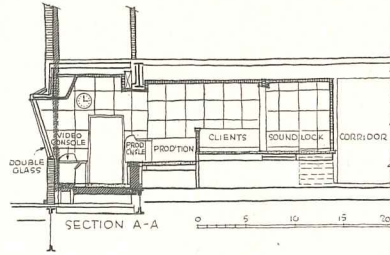

11

Below: 12. Control room equipment and sightlines suggested by General Electric engineers

Above: 11. Section and plan through control room, new CBS studios in New York. Sponsors are separated from program director only by a rail, which is not common practice. Shaded areas show ducts for electronic connections in control room and telecine studio

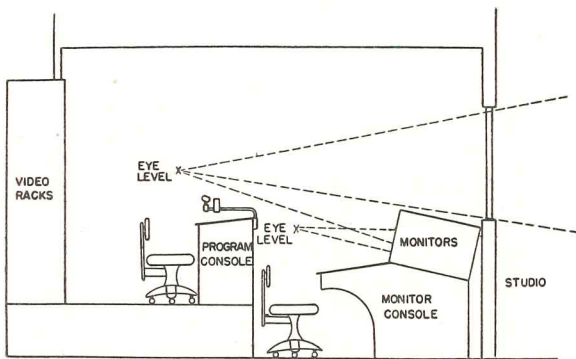
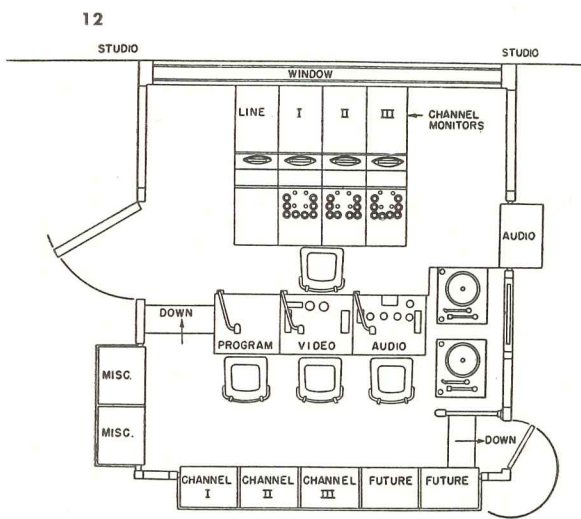

Considerable parking area on the site is desirable. Convenient access for truck deliveries and garage space for the mobile TV unit are musts. Noise in the locality, airborne or carried into the studio by the soil or building structure, may cause trouble; occasionally this problem may render undesirable an otherwise satisfactory location. If the building has other tenants, their noise-producing activities must be considered; pumps, fans, printing presses and industrial machinery are offenders.

**"Live" Studios** Technically, video and audio equipment constitutes the heart of the TV plant, but building design usually centers around the studio for live talent. Here the practical requirements of TV — sometimes as many as eight sets ready at one time in one studio, room for the numerous operating, producing and acting personnel, equipment, and lighting evolved from stage and movie techniques — take precedence over such matters as acoustics. For a non-audience studio, NBC finds an 18-foot ceiling the absolute minimum, with some disadvantages; 22 feet is preferred, 25 desired, and for

Control Rooms. 13, 14, Studio 8G control, WNBT, New York, is on mezzanine. 15, WABD Studio A. 16, Master control, WFIL, Philadelphia

13



14

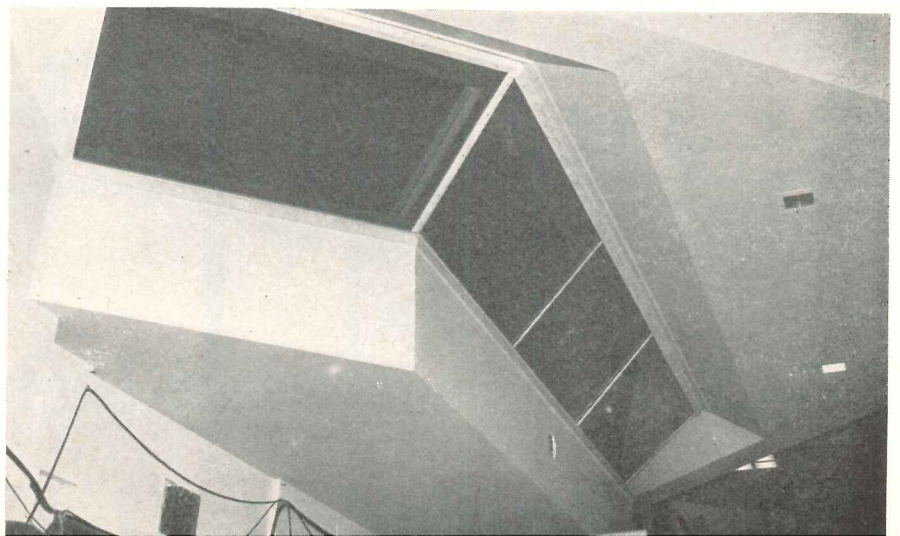



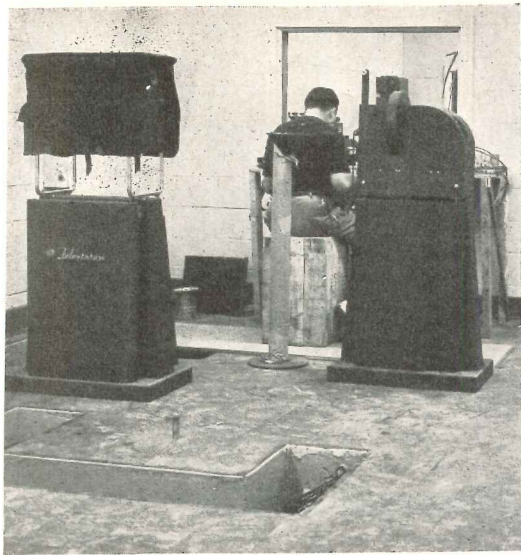

19

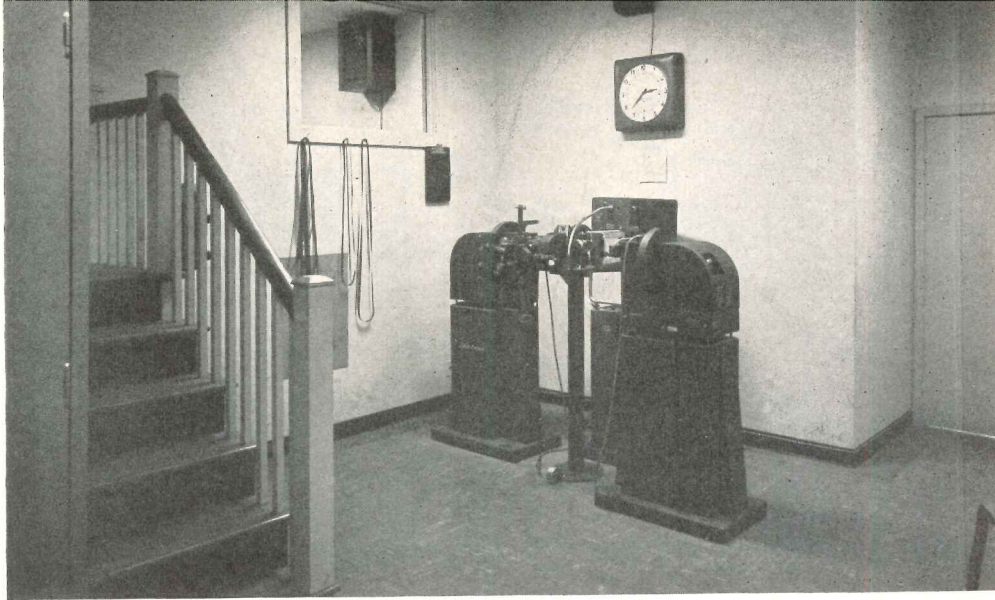

18

19. Installing equipment, telecine studio, KNBH; note floor chases for electronic wiring. 18, Telecine studio, WHEN, Syracuse, N.Y.; stairs lead to control room. 17. Transmitter building, Station KNBH, Hollywood, Calif. Note "turnstile" TV antenna

some studios designed to permit up-angle shots, 35 feet. Some telecasters believe there is no maximum, others that more than 25 feet is wasted; if sets are to be flied or if lights are to be manipulated from a suspended catwalk more height is needed; air conditioning such high rooms is costly. All these factors must be weighed. In area, 25 x 40 ft. is probably the smallest practicable, 30 x 50 is a desirable minimum, 40 x 60 or 40 x 80 is preferred; yet many stations have smaller studios. Entrances should be protected by sound locks and even if the studio is not sound-isolated, it is often surrounded by corridors, storage rooms or offices to reduce noise penetration. Building equipment, which is more fully discussed below, has some definite effects upon studio design.

**Auditorium or Theater Studios** Shows which demand audiences introduce the problem of providing for 300 to 500 people — seldom more — extraneous to the production, who cannot be admitted to the studio floor and whose convenience has less importance than that

15

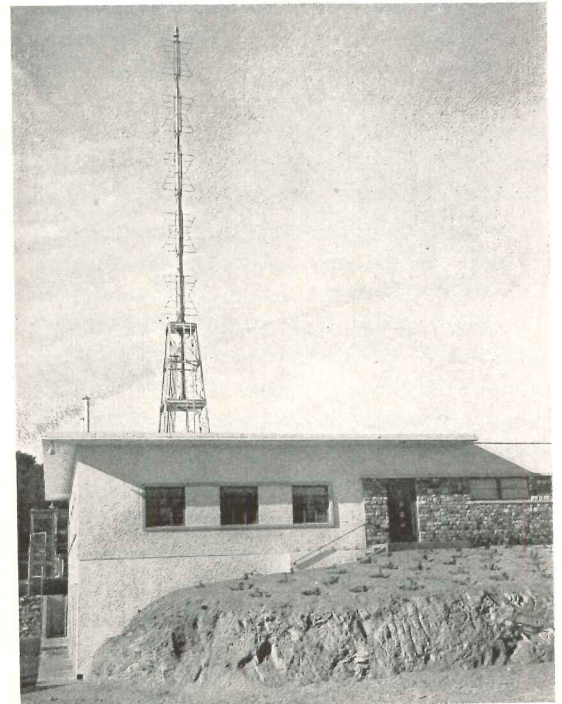

17

16

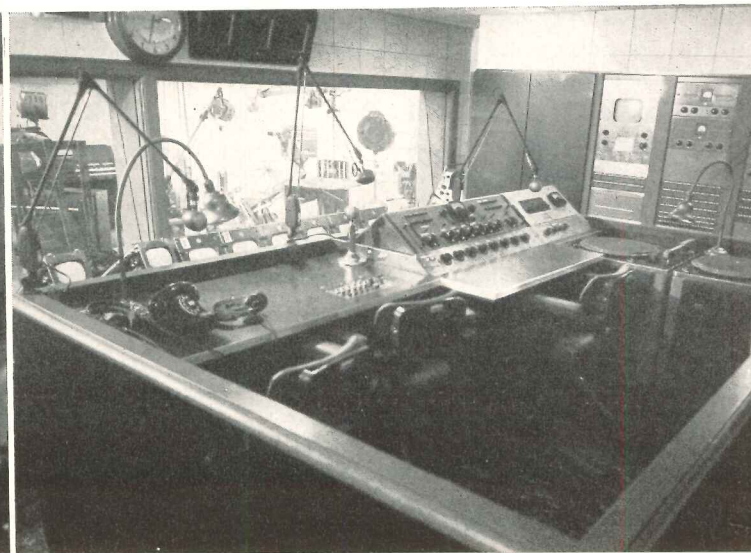

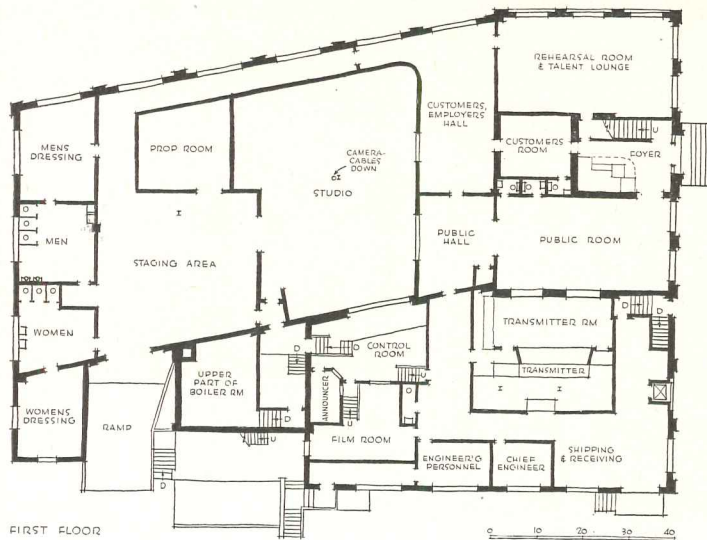

20

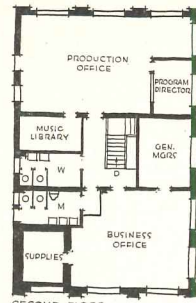

SECOND FLOOR

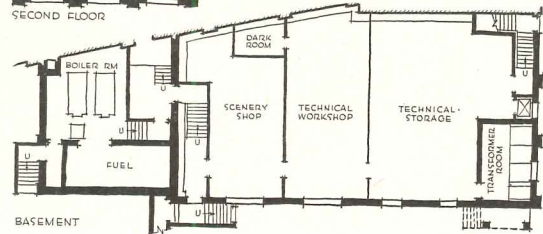

BASEMENT

20, 21. *WHEN*, in a remodeled factory, functions well although circulation appears devious. Column in center of studio affords a central location for camera cables. Note large staging area for scenery, etc., for successive shows

of the audience which sees the telecast on a \$199 receiver. The studio audience cannot be close to the performance because cameras and microphones must move about freely. It is often seated in a steep balcony (which may require a high ceiling), separated from the studio floor by a rail. Since many productions in this type of studio are musical, the acoustic properties may receive more attention. Several radio studios have been adapted for TV audience shows and function fairly well. Adaptation of legitimate theaters has both proponents and opponents; lighting and microphone installations are difficult enough, but providing for the desired three TV cameras becomes a real problem. There is usually one camera in the center; ideally this should be able to "dolly in" for close-ups, which may necessitate a runway similar to that in a burlesque theater. To give roundness to the televised actors and reality to the telecast performance, the other cameras may be at the sides of the auditorium, one perhaps lower than another. Only after experimenting with camera angles can camera platforms be built in with surety. The control room in a remodeled theater might be in a side box; in a new theater it might be under the raised audience space.

**Film or Projection Studio** These have in the past consisted of a room in which movie and slide projectors are positioned against glazed ports in one wall, on the other side of which a TV camera has been shuttled back and forth to pick up succeeding reels. Recently multiplexers (previously mentioned) have been developed; space requirements for these appear on accompanying plans. Much movie film is 35 mm. and inflammable; for this, fireproof storage vaults, vented to the outdoors, are needed. 16 mm. film, non-inflammable, is also used and requires cabinets only for storage. Both film projection and kinescope recording (which is to TV as transcription is to radio) necessitate processing, cutting and rewind space.

**Announce Booth** Usually placed so it has a view through double glazing into both studio and control

room, the announce booth in some large stations is isolated from the studio. Occasionally it is supervised only from the master control room. Whatever its location, the booth is usually an interior room for a single person, who requires an audio and a video monitor like those in the control room.

**Control Rooms** The studio control room contains video consoles which house part of the electronic equipment and monitors which show the picture recorded by each TV camera; racks for more electronic equipment; more consoles for audio control; at least two "turntables" (record players); a monitor TV screen on which the actual telecast appears; and room for two or three video operators, an audio operator, the program direc-

25. Control room, *WHEN*, showing windows into film room and announce booth. Operating desk (another variation on program director's equipment) in foreground, video console just visible at lower right corner

25

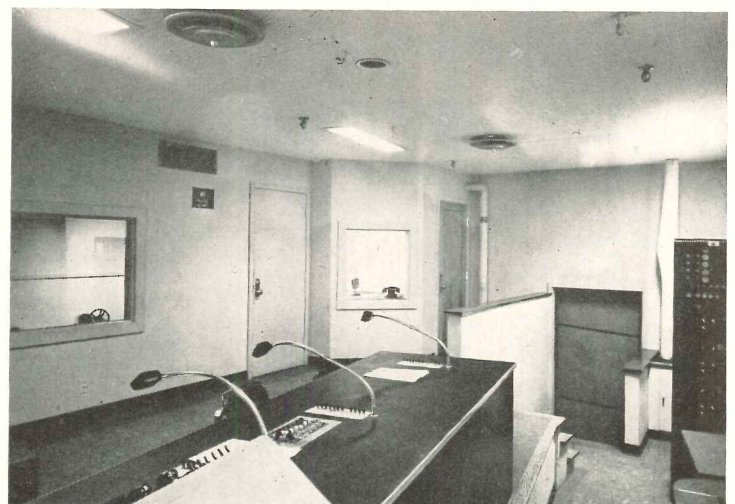

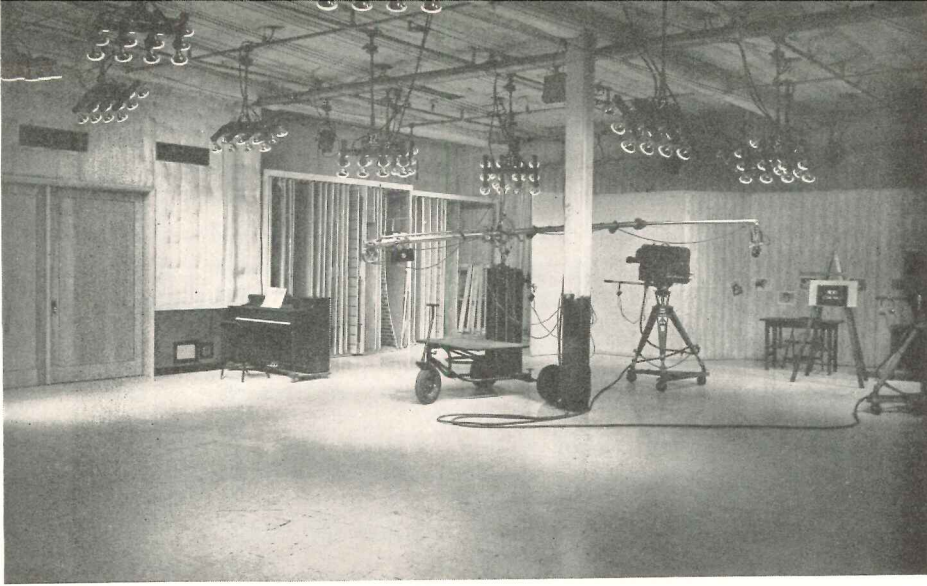

21

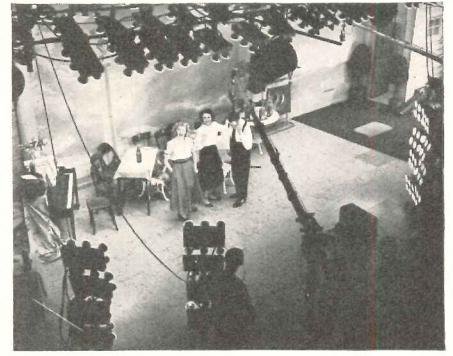

22

22. Lighting by incandescent reflector lamps, WABD. 23. Lighting with slimline fluorescent banks, WPIX, New York

tor, and often a script girl. For a large studio the control room might be 16 x 24 ft.; for a medium-sized studio, 14 x 16 ft. Equipment is usually though not always set on two levels, with the director and audio operator 2 ft. above the other operators, so the director can see over the video technicians' heads. Ceiling height is 8 ft. above the higher level. In most cases the control room is centered on one long wall of the studio, with a double-glazed window set with its sill 3' 10" to 5 ft. above the studio floor, and with the lower control room floor 2 to 4 ft. above the studio floor. In other instances, the studio control room is a full story above the studio floor; sometimes the window is flush with the studio wall, sometimes it projects into the studio and is glazed on three sides; there are those who believe the director should work entirely from the monitors, in a control room which has no view at all of the studio.

The master control room, required where there are more than two studios, is similar in equipment to studio control, but need not have a direct view into studios. Here switching from one to another program and ultimate refining of the telecast are done. This may be a very large space; for a two-studio station, 15 x 25 ft. to 18 x 26 ft. should suffice. In a one-studio station master and studio control may be combined, or there may be one control room for the live studio and a combined master-and-film-studio control. The combination can be accommodated in a 16 x 17 ft. room with an additional equipment room about 9 x 17 ft. Master control consoles may be arranged in U shape for operating convenience. In WJZ-TV's new studios, the film studio has a separate control room from which film may be fed into any studio as well as telecast independently. In the very small station everything is controlled from one room, which may also contain part of the transmitter equipment.

**Transmitter Rooms, Technical Shops and Offices** Method of operation and size of the station govern transmitter room requirements; for a one-studio station, all transmitter equipment and personnel can be accommodated

23

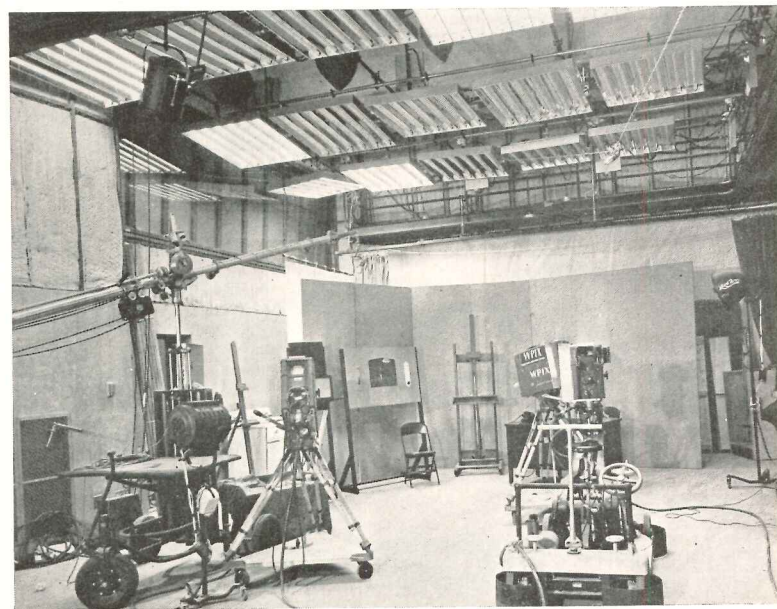

24. Lighting catwalk and fixtures suspended on rods, WCBS-TV, New York. Fixture positions are set from below with poles or from ladders

24



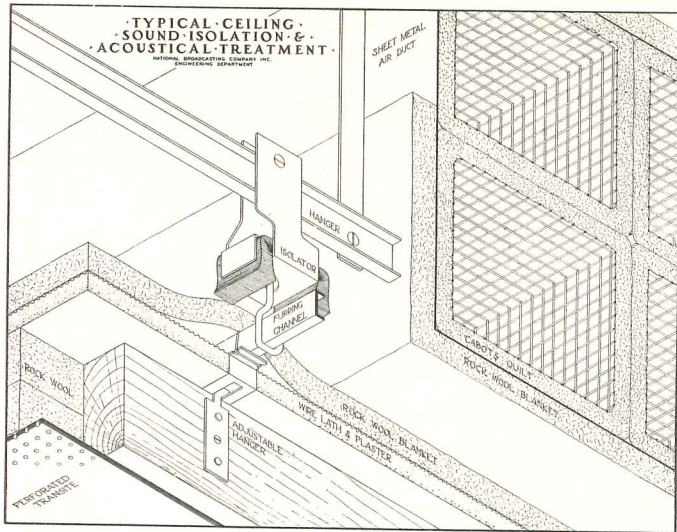

26

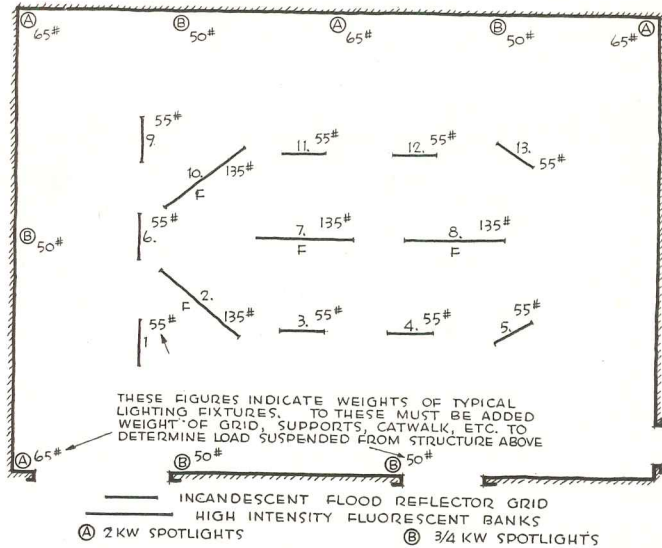

27

in a room approximately 24 x 30 ft. In other cases the room must be appreciably larger. Occasionally station operation makes it advisable to include some transmitter equipment in the master control room, sometimes in a combined studio-master control. An engineering workshop is needed for equipment maintenance and storage, and the chief engineer usually needs a private office. When the transmitter tower is not at the studio loca-

30



tion, part of the equipment may be at the studio and part at the transmitter building, or all at the transmitter, where an announce booth may also be included. A direct line of sight is required for relaying signals from studio to remote transmitter by microwave but not when signals travel by coaxial cable.

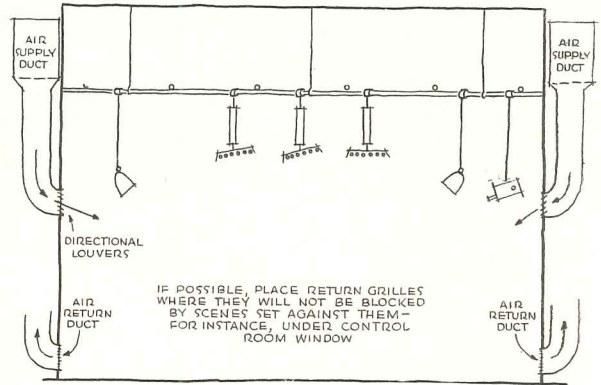

28

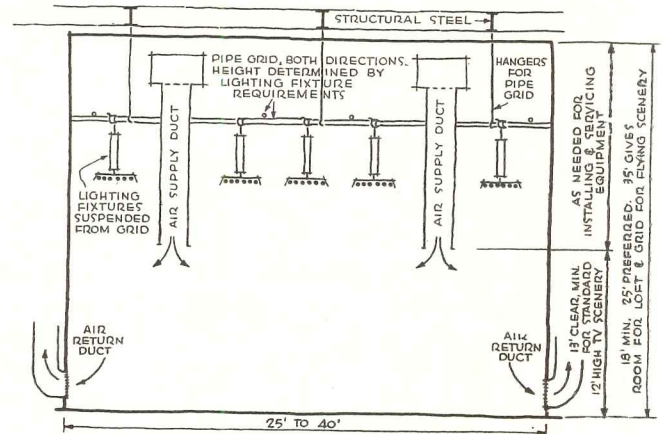

29

**Production and Talent Areas** For live talent (actors, lecturers, performers), provisions are much like those in the legitimate theater: direct access from building entrance, dressing and make-up rooms, toilets, a lounge, all dependent in size and number upon the extent to which live shows are contemplated. Production areas are also similar to those in the theater, with the added considerations that shows must change quickly (meaning immediate, easy access), that many articles are borrowed or rented for one performance only (necessitating truck deliveries convenient to the studio), and that many of these objects are large and weighty (requiring wide entrances, floors capable of bearing heavy loads and with durable surfacing in studio, shops and delivery areas). Spaces required include a scene dock

(Continued on page 178)

Suggested TV theater; audience space is elevated above production floor, and extends over it to give room for camera manipulation

by Elwell, Art Director  
NBC Television

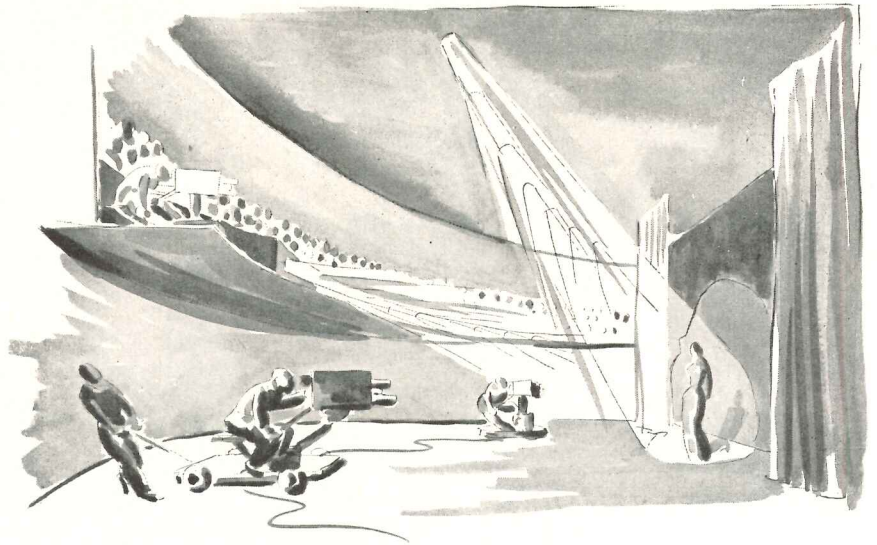

## THE TELEVISION PRODUCING PLANT

Notes on some essentials, excerpted from a comprehensive study made by one of the industry's top designers

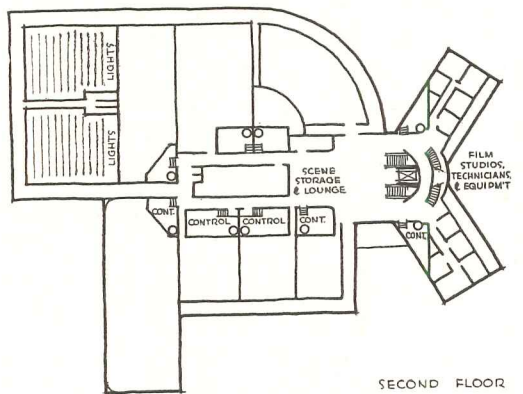

SECOND FLOOR

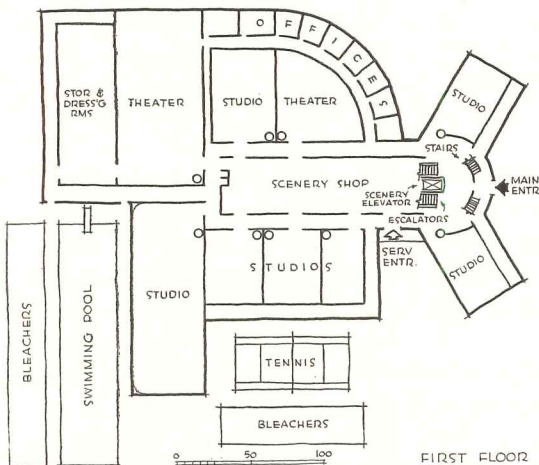

FIRST FLOOR

First and second floors, suggested TV building; basement houses storage, rehearsal rooms, ports for underwater shots into swimming pool; third floor, restaurant, etc. Adjacent sports facilities make possible telecasting under studio conditions.

STRAIGHT LINE travel is essential for efficient television production. For quick moving, everything visual (scenery, props, effects) should be on one level, and all audio and video control should be on another level to avoid interference. To reduce handling, mechanical and manual, of scenery, props, and electronic equipment, one should be able to move it directly and *horizontally* from rolling transportation into place in shop or studio. Even using an elevator consumes time, which is of prime importance. Hence it is advisable to set first floor level at the height of a truck bed above grade.

A TV plant functions best if designed at the outset for maximum likely performance — 24-hour telecasting — and, if this is not immediately feasible, reducing the scheme, but always so that additions can be made without impairing efficiency. Building size depends upon quantity of rebroadcast network programs plus number of "live" hours desired. Circulation is complex; in the accompanying plans, the 10-ft. corridor surrounding the shop is a sound baffle as well as a hall in which production and technical personnel can move quickly from studio to studio while, equally quickly, scenes, costumes and props, perhaps from two different shows, may also be passing. The public (audiences) is never permitted to enter the first floor or the studios proper; it moves directly to the second, to seating areas of TV theaters only. Audiences are composed of 300 to 500 people per show.

A studio here means a workshop for producing TV shows which need no audience; a TV theater, for those which do need audiences. Two theater types are shown, a large one for plays, musicals, symphonies, basketball, etc., and a smaller for lectures, soloists, and other restricted presentations. Live telecasts require a studio not smaller than 30 by 50 ft., with a normal ceiling height of 18 ft. to accommodate 12-ft. high scenery; the main sight interest is 6 ft. above the floor, centered about an individual's head. The exceptional high-angle shot may demand a 28 ft. ceiling, so one studio this high is advisable. Rehearsal space under all studios, exactly the size and shape of the studio above, permits exact blocking out of action, cameras, etc.



## WBZ RADIO AND TELEVISION CENTER

*Architectural Dept., Westinghouse Electric Corp., Designers*

*Boston, Massachusetts*



**I**N 25 YEARS of broadcasting WBZ has grown from a simple monks-cloth-draped penthouse at Westinghouse's East Springfield works, first to quarters in a succession of hotels, now to this new plant on Boston's Charles River, housing WBZ-WBZA, WBZ-FM, WBZ-TV. Television studio (45 by 50 by 23 ft. high, sound-deadened with mineral wool on walls and ceiling) and control, projection and production spaces are grouped so facilities common to TV and radio can be used jointly. Circulation is particularly well handled. Auditorium-studio A, primarily radio, has TV camera and lighting outlets, seats 160, is 35 by 68 by 18 ft. high with stage 22 by 30 ft. TV film, network, studio and remote shows are controlled in TV equipment room. Studio flooring, left, is rubber tile to take heavy traffic.

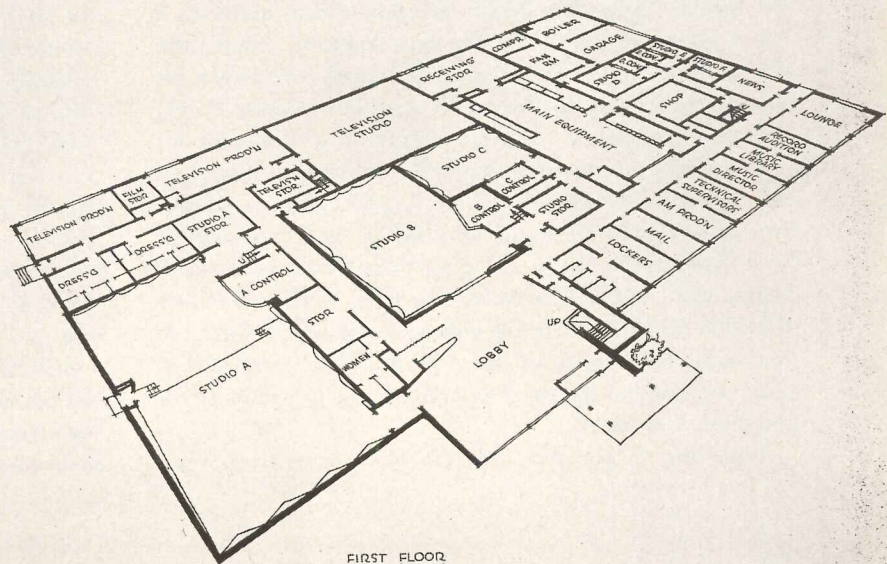
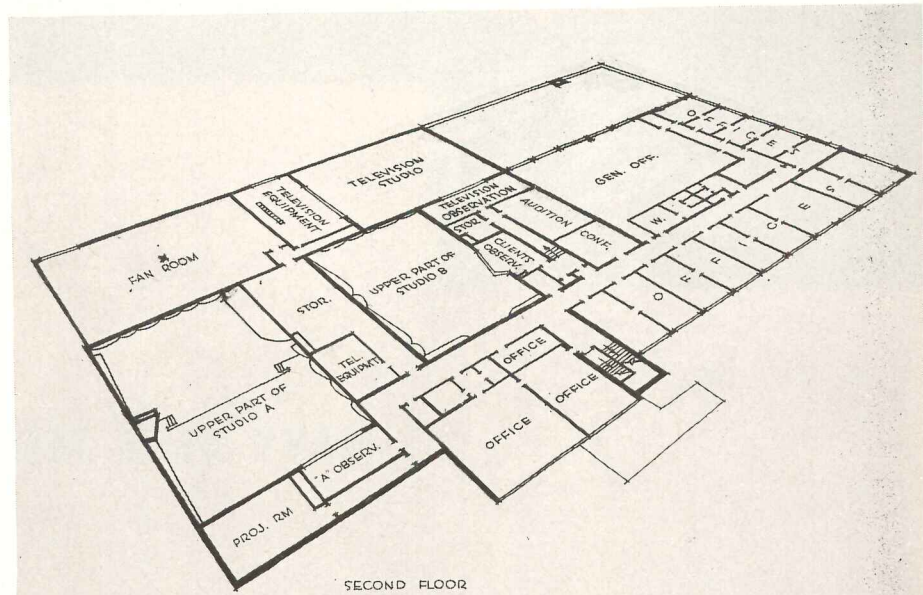

Above, WBZ-TV mobile truck. Below, film projection room: TV cameras, movie and slide projectors and multiplexers; film camera control consoles in foreground. In plan, note segregation of public, administrative, talent, technical and production traffic; also receiving space near equipment room and TV studio, actors' rooms serving TV and radio studios.



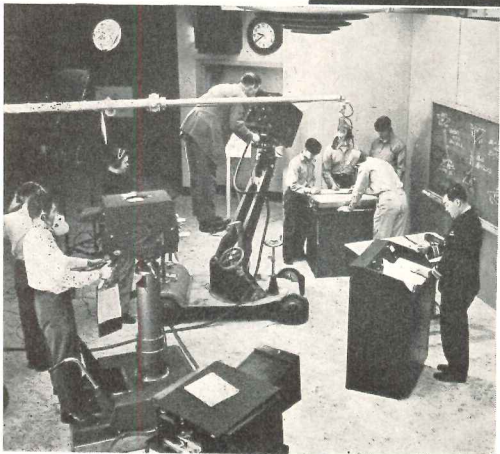
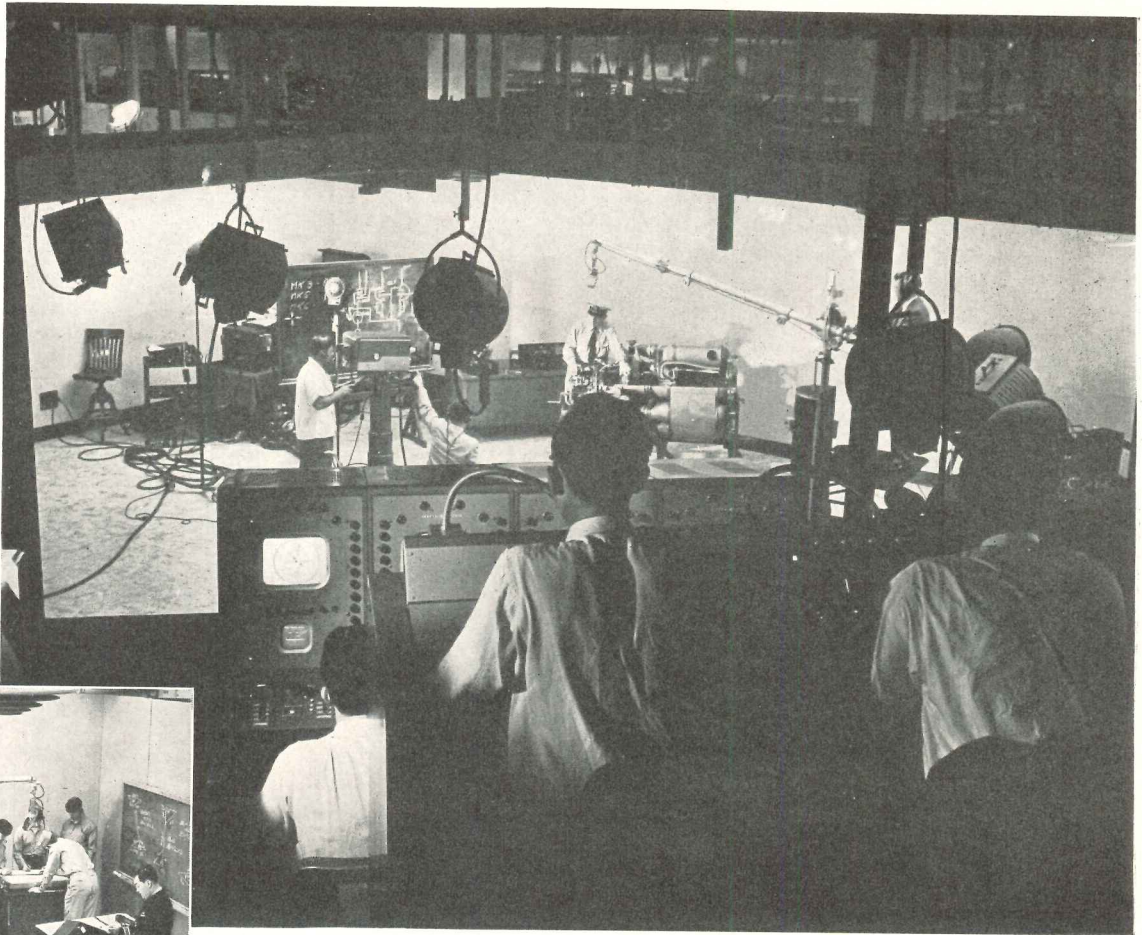

*Special Devices Center, U. S. Navy*

*Sands Point, N. Y.*

## NAVY USES TELEVISION FOR TEACHING

**E**XPERIMENTAL television broadcasts to classrooms distant from the studio are now being made in a Navy investigation of TV for mass training. Under the direction of the Office of Naval Research, lectures were first beamed from the Navy TV station at Sands Point, Port Washington, N. Y., to a classroom at the same location. Last January thrice-weekly telecasts began to the Merchant Marine Academy 5 miles away; soon the broadcasts, via cable and microwave, are expected to be utilized as far away as Squantum, Mass., and Anacostia, Md. The TV lectures are part of the standard NROTC curriculum in 52 colleges and universities. A thorough evaluation of the TV-training program is being supervised by the Department of Psychology of Fordham University.

Achieving a personal relationship between the in-

structor in the studio and the trainee in a distant classroom is an important objective. The Navy has announced tests to develop a TV classroom, inquiring into suitable size, shape, seating, acoustics, illumination, size of TV screen, and placement of microphones which will enable trainees to ask questions directly of the remote instructor. Eventually a prefabricated classroom might be developed. In the studio, because participants' activities are more localized than are those in commercial TV, lighting can be to a great degree fixed; fixed lighting sources reduce interference between lighting and air outlets placed as shown. This permits an extremely efficient air conditioning system, one which makes no attempt to condition the unimportant space above lighting fixture level. Air conditioning apparatus is isolated against sound and vibration transmission,



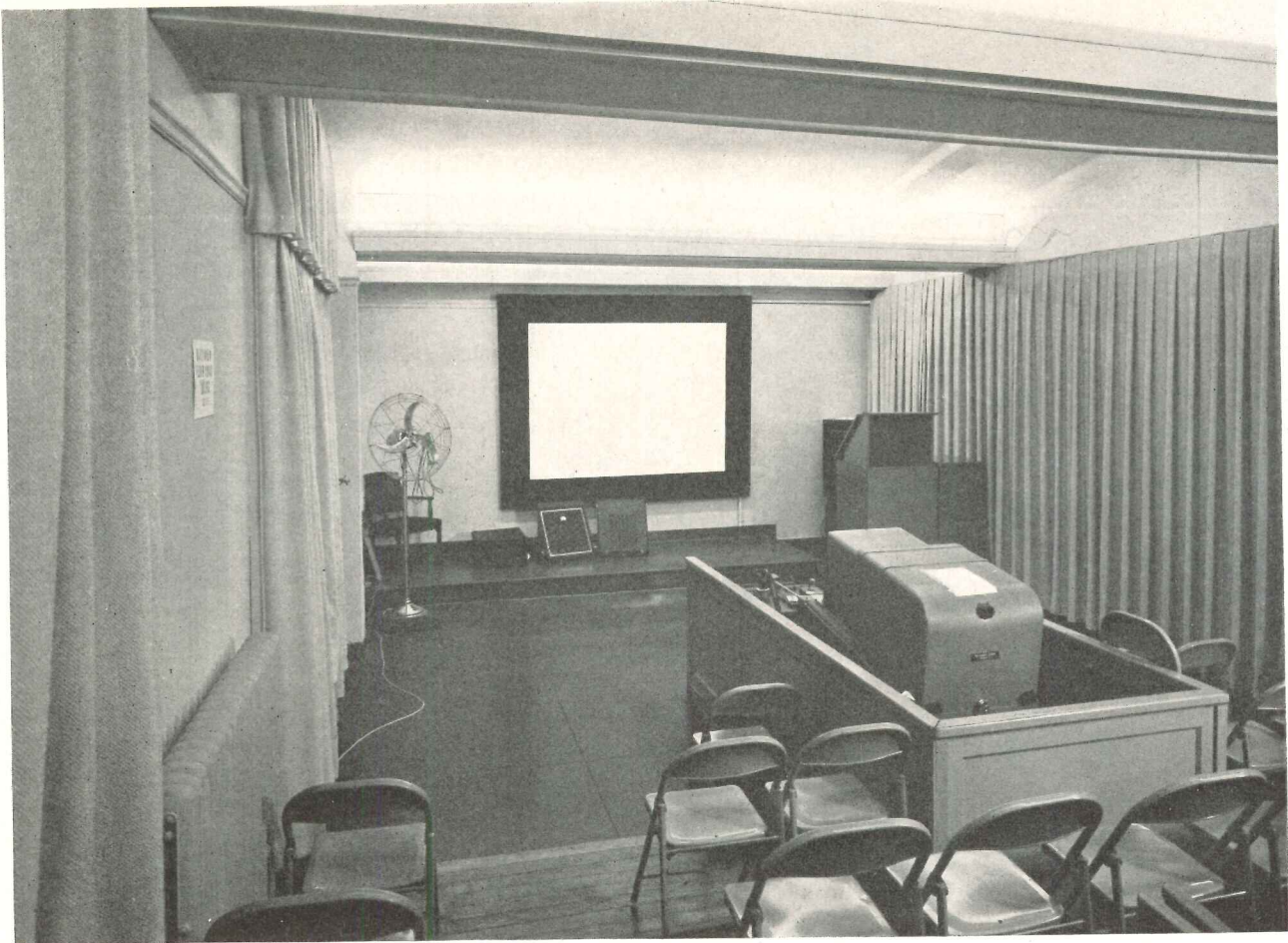

Photos this page by Joseph W. Molitor

Facing page: TV control room and studio, with lecture and demonstration in progress. Above, experimental receiving classroom; right, large-sized air conditioning ductwork, sound-deadened, in basement below studio. Bottom left, studio lighting (fluorescent troffers, fixed and portable floods, spotlights) and air conditioning outlet in center—possible only when lighting is relatively fixed. Bottom right, electronic racks, accessible front and rear for ease in servicing.

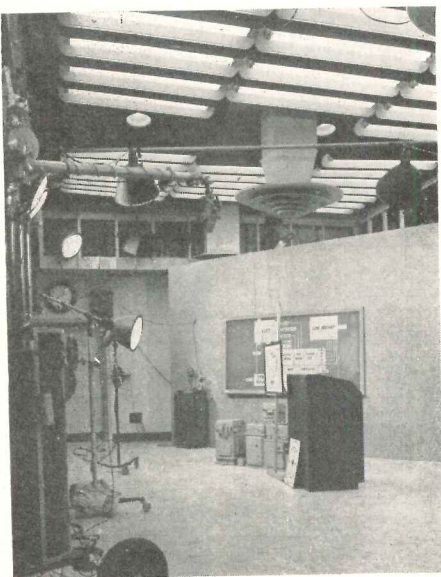
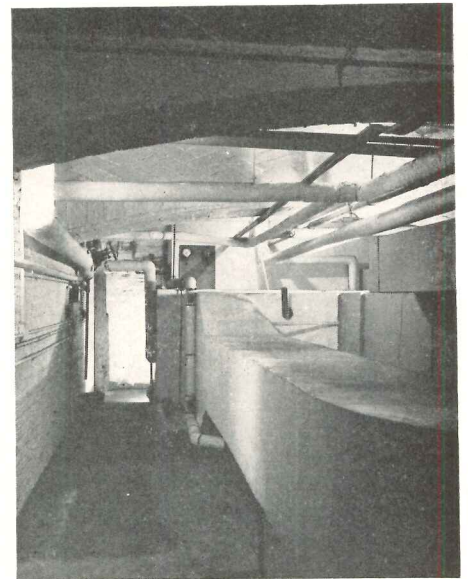



**WICU**

*Erie, Pa.*

**DUMONT NETWORK AFFILIATE**

*Nelson and Goldberg, Engineer and Architect*

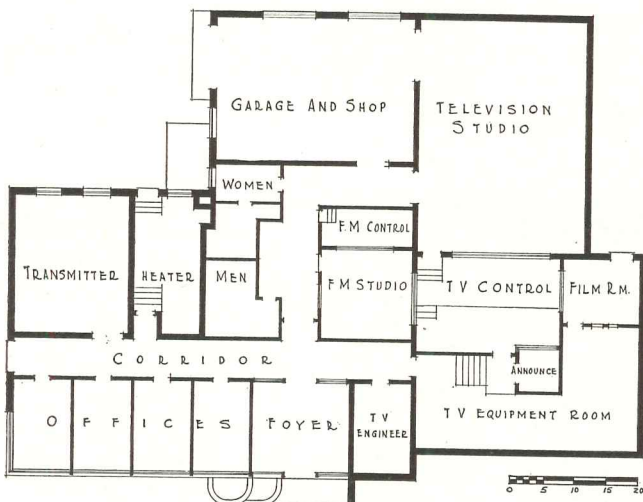
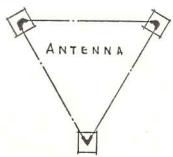

STATION WICU, completed late in April, 1949, is a small, limited-budget, one-studio television plant. Its plan is organized to permit operation with minimum personnel; special provisions for audiences are omitted because most live shows will come from networks. On occasion a few live shows may originate in WICU and others may be televised from local sources. When necessary, the studio can hold about 100 people. Limiting the local live program has made possible omission of some production and talent spaces and reduction of others. Grouping both studios (one for the FM component of the telecast), FM control, film room, announce booth and TV equipment about the TV control room helps reduce operating personnel. Equipment room is designed for double present requirements and transmitter room is located so it can be enlarged readily. Acoustic treatment is kept to a minimum in FM studio, eliminated in TV studio, where portable drapes and scenery are relied upon to deaden sound. Air conditioning has not been installed, though provision is made for future packaged air conditioners; at present recirculating air heating and individual ventilators change the air in non-fenestrated rooms; transmitter room has a power exhaust for heat generated by the equipment. Construction cost approximately \$12 per square foot.

In contrast, the 3-million-dollar Mutual-Don Lee

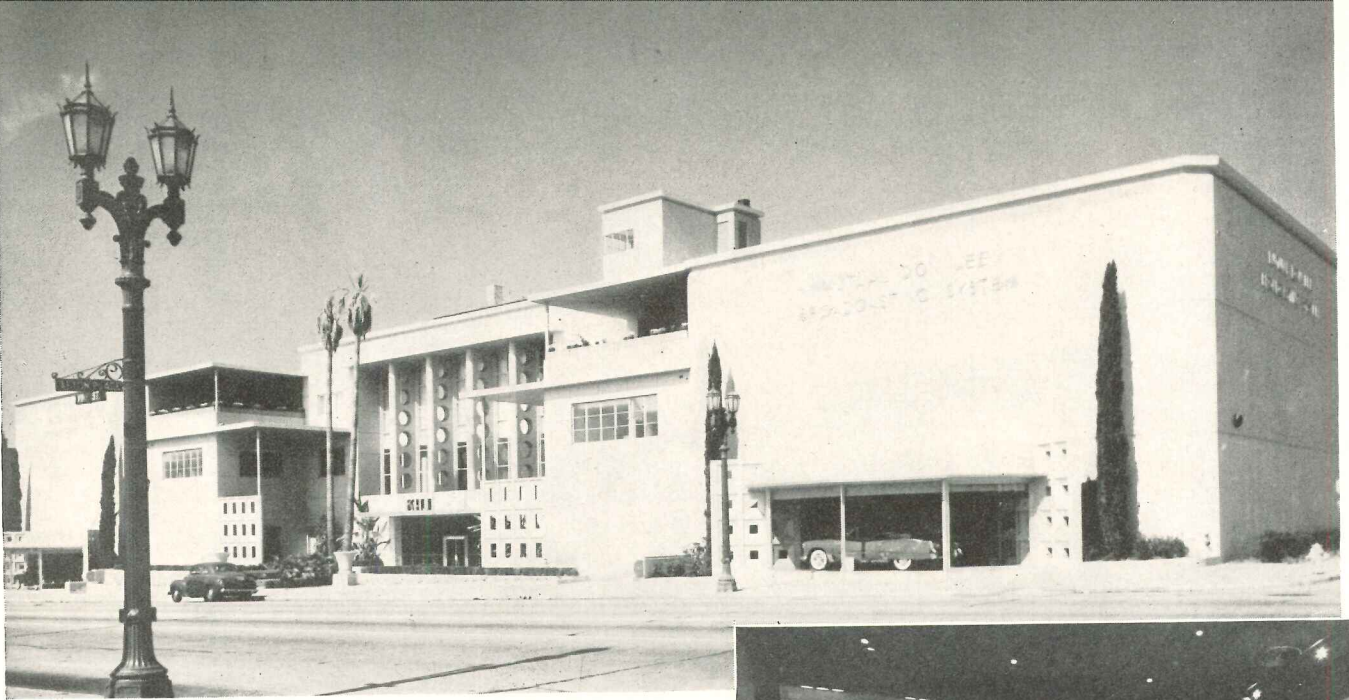

**KHJ** *Hollywood, Calif.*  
**MUTUAL-DON LEE**  
**PRODUCTION CENTER**

*Claude Reelman, Architect; Herman Spackler, Associate*



building is a two-story, 14-studio radio and TV center where live shows originate. Covering a whole city block, it has ample parking space at the rear (not shown) and is noteworthy for its excellent circulation. Studio audiences may enter any of the theater-studios from the street; talent can proceed directly to dressing rooms and stages; administrative personnel is on second floor, which contains executive, business and sales offices, audition rooms, publicity department, and (on mezzanines) clients' booths and echo rooms for theaters. Each theater is 115 by 65 by 33 ft. high, has a 60 by 65 ft. stage for a 100-piece orchestra, and seats 350 people; all are permanently equipped for TV. There are four theaters, four non-audience studios, three commentator-and-disc-jockey studios, and three announce booths. Master control, set behind a sound-proof window into the main lobby, is 33 ft. long, 10 ft. high, weighs 8½ tons; through more than 800 switching positions a single engineer can handle as many as six programs running simultaneously through the board over 14 outgoing and incoming network lines, as well as circuits from studios, recording studios, cue circuits, video circuits, remote circuits, and house monitors. Basement houses sound-isolated air conditioning apparatus, storage space, employees' lounges, etc. Large studios are all "floated" construction for sound isolation.

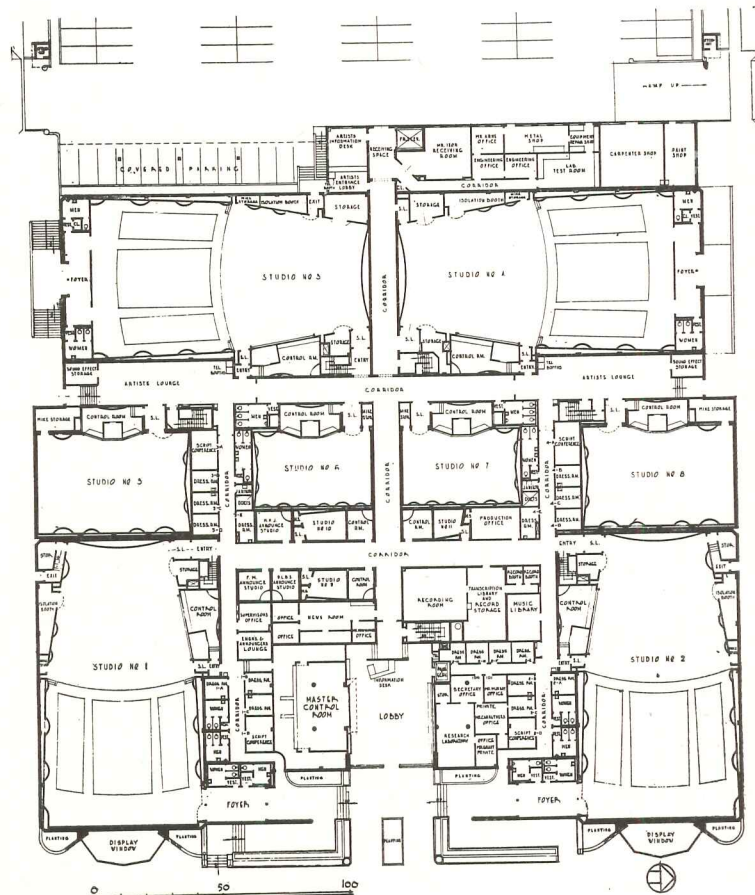



## WHAM, THE RADIO CITY OF ROCHESTER, N. Y.

*W. G. Kaelber & L. A. Waasdorp, Architects*

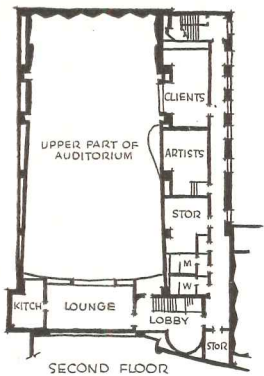

THE recently completed Stromberg-Carlson station, WHAM, provides for AM and FM radio and television. The five smaller radio studios and large auditorium studio are sound-isolated, with floating walls, floors and ceilings inside the reinforced concrete structure. TV studio, approximately 45 by 55 ft., was included in initial design but was completed after the remainder of the building, in time for telecasting to start in late spring, 1949. Access for bringing large props and scenery into the TV studio seems restricted, but some programs may be handled from Studio A. Note economical layout of TV equipment, film studio, vault, shop, transmitter.

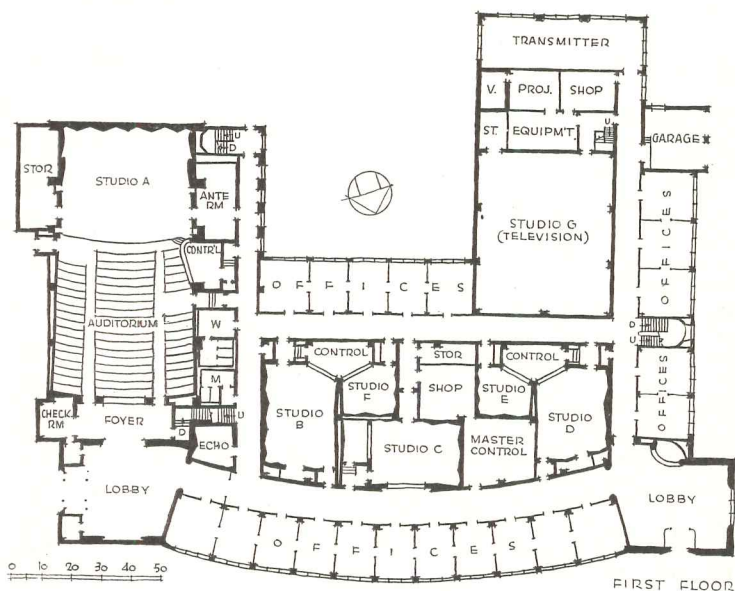

Tile and face-brick walls and concrete floor slab are carried by a peripheral grade beam, 12 by 24 in. in size, which rests on footing posts, all of concrete. Roof (built up, on gypsum decking) is framed with 24 in. open-web steel joists; top flanges are extended to carry overhangs; clear span is 45 ft.; interior partitions are non-load-bearing. Beneath floor are chases for radio wiring and air conditioning ducts

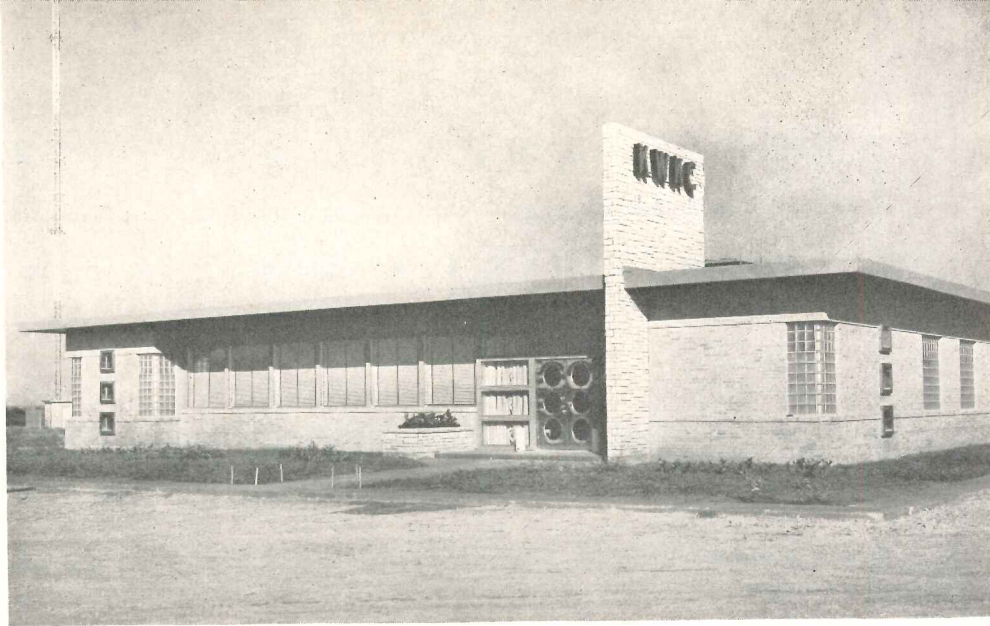

## KWKC, SMALL FM RADIO STATION IN ABILENE, TEXAS

*Hughes & Olds, Architects and Engineers*

STATION KWKC, built in 1948, is a radio studio and transmitter building for the Citizens Broadcasting Co. The two studios and announce booth grouped around the control room can be augmented by converting adjacent storage space; like the other studios, this has been constructed with acoustically surfaced walls and ceiling, with mineral wool insulation in the studing. News ticker, though well isolated, is nevertheless convenient in a small station.

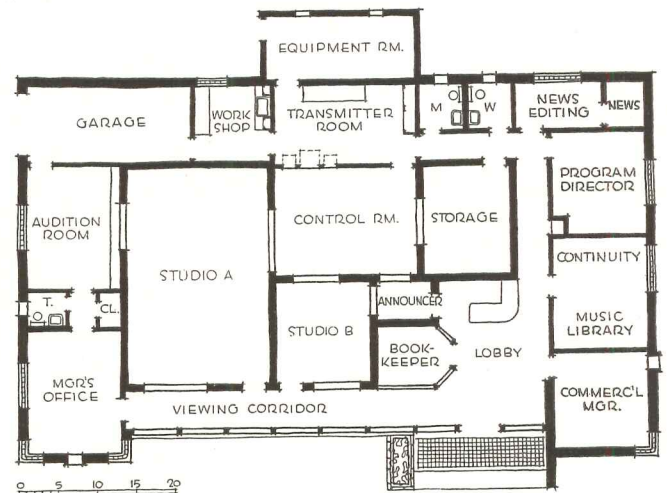

### CONDENSED BIBLIOGRAPHY: BUILDING FOR TELEVISION

Note: Television has progressed so rapidly that few publications on its building requirements exist, and most of these are outdated. Much information is contained in periodicals; space permits listing only a few articles from such sources. Additional information can be obtained from the editors of the various magazines.

#### ARTICLES, BOOKS

- American Television Directory, The*, American Television Soc., 17 E. 45 St., New York, N. Y. 1946
- Challenge of Television, The*. John Flory. Educational Screen vol. 23, p284.
- Facilities Housing for TV*. Brugnoli and Adler. Broadcast News.
- Forecasts in FM and TV*. Columbia Broadcasting System, New York, N. Y. 1945
- Official Yearbook of the Television Industry*. Television Broadcasters Ass'n., 500 Fifth Ave., New York, N. Y.
- Planning the Television Station*. A. N. Goldsmith. Televiser, Nov-Dec 1945
- Practical Equipment Layouts for TV Stations*. Broadcast News.
- Radio Broadcasting and Television* annotated bibliography). Oscar Rose, ed. H. W. Wilson Co. N. Y. 1947
- Story of a Penthouse Station*. S. H. Cuff. Televiser, Jan-Feb 1946
- Telecasting and Color*. Kingdon S. Tyler. Harcourt-Brace. N. Y. 1946
- Television Encyclopedia*. Stanley Kempner, ed. Fairchild Pub. Co. N. Y. 1948
- Television Show Business*. Judy Dupuy. General Electric Co. Schenectady, N. Y. 1945
- Television Station Costs*. Wm. Foss. Electronics, Dec 1948
- Television Studio* (revolving stages). Arch. Forum. May 1944, p6.
- Truth about Color Television, The*. A. B. Dumont Laboratories. N. Y. 1946

*WFIL's TV Studios*. L. E. Littlejohn. Broadcast News, Sept 1947, Oct 1948

#### PERIODICALS

- Broadcast News*, Radio Corp. of Am., Engineering Products Dept., Camden, N. J.
- Broadcasting*, National Press Bldg., Washington 4, D. C.
- Communications*, 52 Vanderbilt Ave., New York 17, N. Y.
- Educational Screen*, 64 E. Lake St., Chicago, Ill.
- Electronics*, 330 W. 42 St., New York 18, N. Y.
- FM-TV*, Savings Bank Bldg., Great Barrington, Mass.
- International Projectionist*, 19 W. 44 St., New York, N. Y.
- Radio Daily*, 1501 Broadway, New York 18, N. Y.
- RCA Review*, Radio Corp. of Am., Laboratories Div., Princeton, N. J.
- Tele-Tech*, 480 Lexington Ave., New York 17, N. Y.
- Televiser*, 1780 Broadway, New York 19, N. Y.

### PRECAST SYSTEM DEVELOPED FOR LOW-COST DORMITORIES

*McKim, Mead and White mix precast and poured-in-place concrete to keep costs down*

EVERY day there are more and more applications of precast concrete, fostered by high material and labor costs plus the urgency of rapid construction for many types of buildings, especially housing.

A method developed by architects McKim, Mead and White for economy in a group of dormitories that has recently aroused considerable interest uses precast wall slabs as the supporting elements. No columns are required except in large areas such as dining rooms and lounges where the columns supplement load-bearing wall slabs. The only beams are spandrel beams between each floor, and these can be omitted when window frames are cast with the wall slabs.

This construction method is unique in that the precast slabs are not anchored to the floor supporting them—they are merely set on a bed of mortar. The structure is tied together by having steel handling hooks (set in the top of

the panels when poured) and the top half inch of the panel cast into and thus made integral with the floor slab above.

#### **Dormitory Studies Made**

The new method resulted from intensive studies conducted by the architects in collaboration with E. J. Rappoli, contractor, and Fred N. Severud, structural engineer, for a dormitory project at the University of Vermont.

University officials requested the architects to design accommodations for about 600 students, to be built at a cost not to exceed \$850,000, including grading, roads, walks, furniture and professional fees. They also stipulated that the buildings be ready for occupancy within nine months.

To meet this challenge, a complete re-examination was made of accepted standards of college dormitory accommodations, with the result that the precast system was evolved and new standards such as smaller room sizes and

the finishing of interiors by painting directly on concrete were considered acceptable.

Very rapid construction and economy resulted from simplicity of design; elimination of many of the conventional construction steps such as plastering, and the work of many trades; use of repetitive shapes of panels; and adoption of the new standards.

Four buildings were erected at the University of Vermont during 1947, providing for 467 students at a cost of \$762,000, including grading, roads and walks. Construction was started at the end of March; two buildings were completed and occupied on Oct. 15 and the remaining two on Nov. 1.

And more recently, the system was adopted at the University of Connecticut. Construction on eight dormitories started in March, 1948; four of the units were completed early in September and the other four before the first of January. These buildings house 1253 students at a cost of approximately \$1,880,000, including treatment of grounds, roads and walks, but not furniture and professional fees. Two additional men's and women's groups, each housing 1200 students, are scheduled for completion in February and July, 1950, respectively.

A nurses' home for Mary Fletcher Hospital at Burlington, Vt. was also built by the precast method.

The new standards that developed out of the studies are: (1) story heights are 8 ft. 6 in. (clear height 8 ft. 1½ in.); (2) plastering and associated work are omitted; (3) a room 11 by 14 ft. accommodates two students; (4) wardrobes are usually provided in place of built-in closets; (5) the toilet fixture ratio is reduced to a minimum (found entirely

*"Air view" sketch of student housing at Univ. of Connecticut, on which work is completed or under way, being built with precast wall slabs. Buildings at top are completed except for bottom of "U," which is nearly done. Work is just starting on remaining ones*

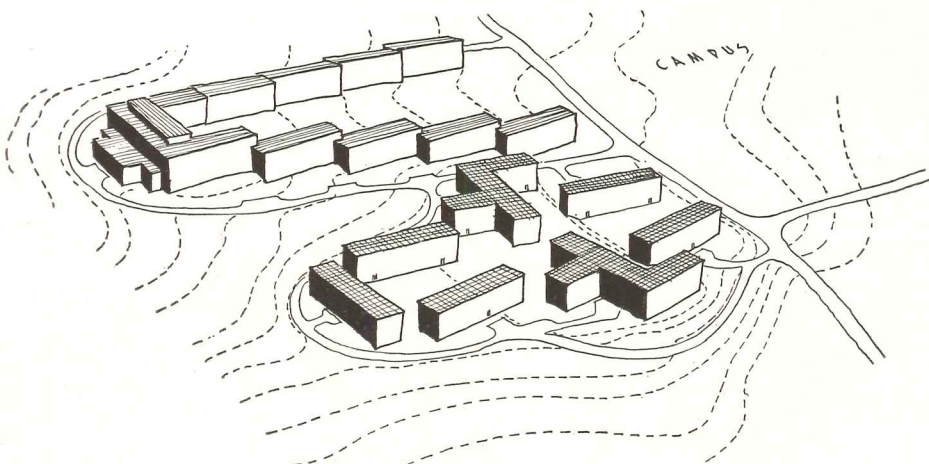

satisfactory to occupants); (6) electrical work is kept to a minimum (each room has two duplex convenience outlets and one lighting outlet).

### The Construction Technique

The slabs are cast one atop the other in edge forms, "sandwich" fashion. Footings, foundation walls and all floor and roof slabs are poured in place. The flat floor slabs are continuous and span from exterior to corridor walls. Each floor, then, serves as a platform on which the next tier of precast slabs is set.

For precasting the slabs, the edge forms are erected on solid, smooth platforms of wood or concrete. Reinforcing steel, and hook bars to facilitate handling, are placed in the form together with any necessary outlets and conduit, and then 2500 psi concrete is poured. The first slab is given a smooth trowelled finish, and after 24 hours is coated with lacquer and then form oil to prevent adhesion of the next slab which is poured on top; sometimes canvas sheets are used as the separating medium. Up to six slabs have been poured in one stack with the sandwich method, but this is not necessarily the limit. Panels have been cast at the site and at points as far as 60 miles from the site.

After a curing period of seven days, the panels are set in place by crawler cranes. Two different means of support have been used to hold the panels until they are finally anchored in place. At the University of Vermont simple wood bracing was used, and then forms were put over the panels for the cast-in-place concrete floors. At the University of Connecticut, the supports for the floor forms were erected first. Slabs of the outer wall were set against the supports, and slots were left for partition slabs.

The precast exterior walls are faced with a 4-in. wall of brick, set 2 in. away from the panels to form a cavity wall. Outer wall panels have galvanized iron channels cast into them to hold the keys which tie the brick shell to the panels. Exterior wall panels, as used in the Vermont and Connecticut dormitories, are 8 in. thick except under window openings. Here a 4-in. spandrel panel is used, set even with the outside face of the wall slab, creating a recess for tucking away convectors and steam risers. Beams above the windows have sleeves cast in them to allow the pipes to go up through. Basement walls consist of 8-in. slabs, facing the interior, separated by a 2-in. cavity from an outer, sand-cast, 5-in. slab. Brick replaces the 5-in. exterior slab above the basement.

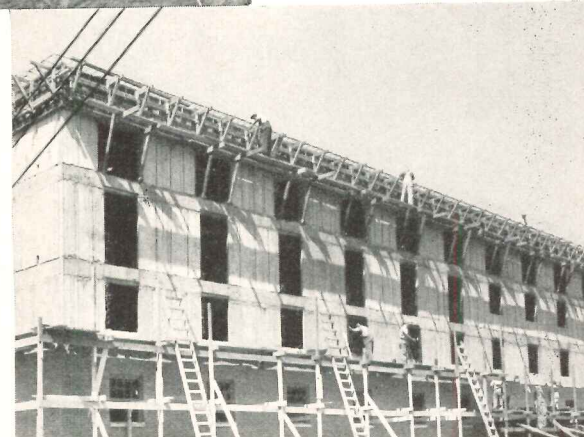
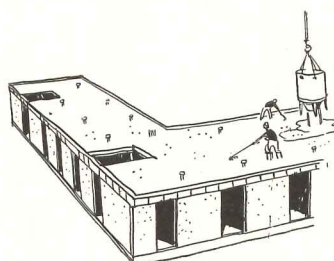
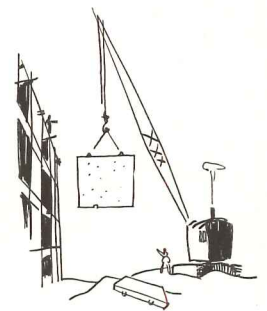
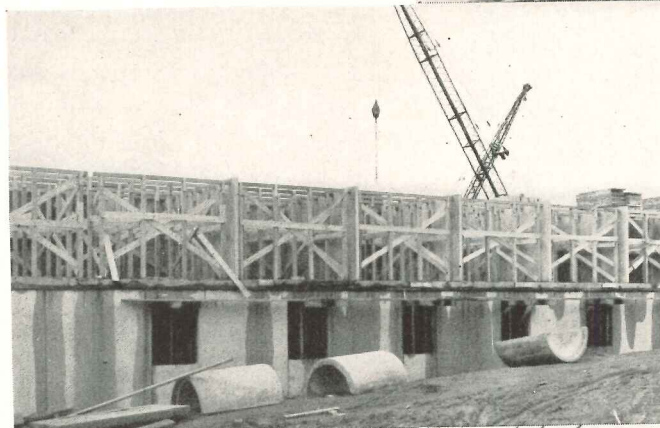
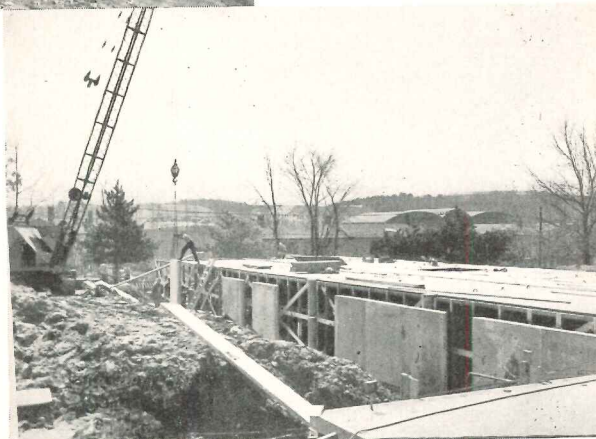
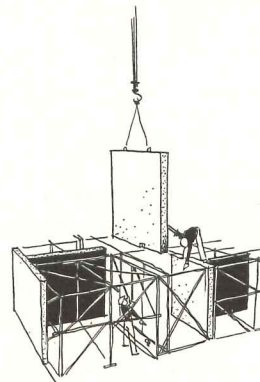
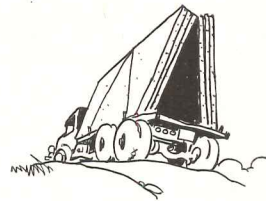
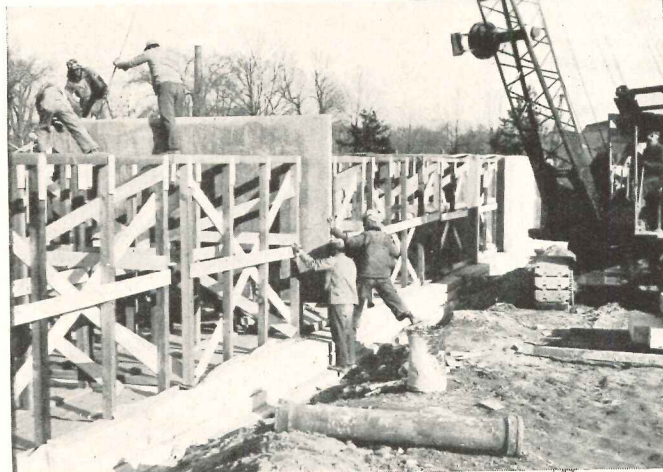
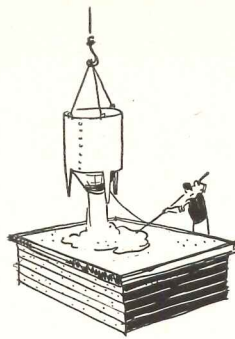

# ARCHITECTURAL ENGINEERING

TECHNICAL NEWS AND RESEARCH



Photo, left: setting up precast wall slabs at the Univ. of Vermont. Simple wood bracing held slabs in place; floors were poured in place in forms built over slabs. Details below photo show typical dormitory construction. Bottom right: some of the first dorms built at the Univ. of Connecticut

Concrete panels used for partitions between the rooms have a notch cast in at the bottom. At this point the electric conduit, which is cast into the floor slab, rises up to permit attachment of double convenience outlets.

All interior joints are grouted, and excess mortar is rubbed down. After removal of the floor slab forms, fins and rough spots are ground if necessary and finished as smoothly as possible, except where acoustical tile is applied, when fins projecting not over  $\frac{1}{8}$  in. are permissible. The interiors besides having the equivalent of plastered room finish have the additional advantage of practically indestructible surfaces. In toilets, kitchens and in some cases stair halls, a glazed brick-tile finish has been used over the concrete panels for sanitary reasons and to reduce maintenance.

On first thought there might be some question about the acoustical qualities of this construction. The architects have found that in bedrooms, the usual furniture and hangings are adequate to create satisfactory acoustical conditions. In corridors, ceilings are treated with acoustical tile, and in later buildings this

treatment is being extended to other spaces. Transmission of sound through walls and floors has not been found to create a serious problem, and the concrete walls are not colder than ordinary plastered walls. The concrete floors are finished with asphalt tile.

Besides the fast construction possible, the "edge slab method," as it is called, provides permanent, fireproof housing at exceptionally low cost.

## BUILDING COSTS WITH PRECAST CONSTRUCTION

Cost per cu. ft.	No. of Persons Accommodated	Cost per Person
\$0.83	567	\$1,344
Univ. of Vermont Dormitories (Minimum amount of lounge space, no dining facilities)		
1.014	1,560	1,662
Univ. of Connecticut Dormitories (Includes dining hall, lounges and kitchen)		
0.97	180	1,860
Nurses Home at Mary Fletcher Hospital, Burlington, Vt. (Includes library, 3 class rooms, large recreation room; no dining facilities)		

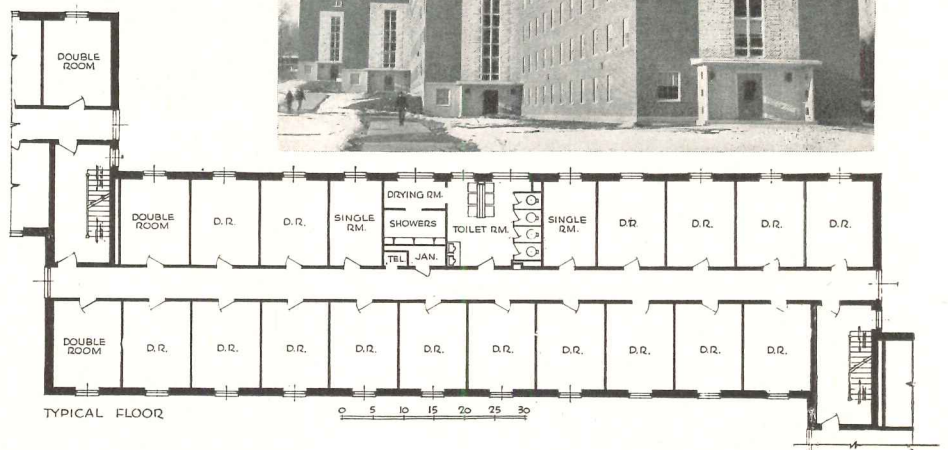
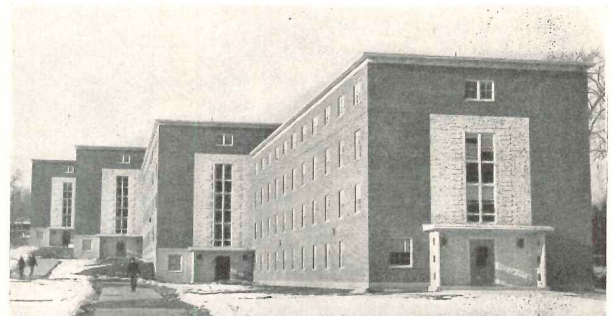
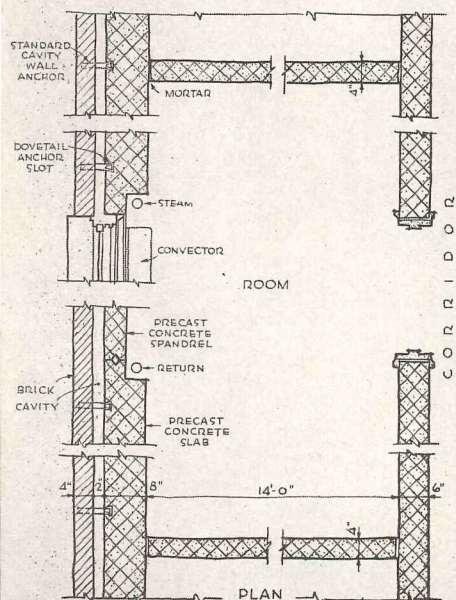
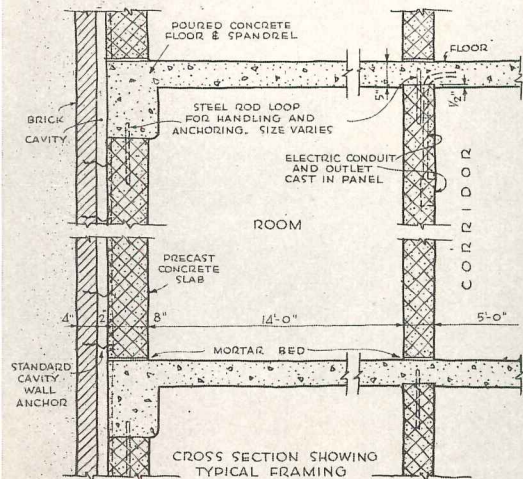



# GLARE-FREE LIGHTING METHODS STUDIED BY M.I.T.

By H. L. Beckwith, C. M. F. Peterson and Parry Moon

Lighting methods, equipment and concepts are changing rapidly these days in an effort to achieve high levels of illumination without glare. A committee was formed at M.I.T. in 1946 to evaluate modern lighting trends especially with respect to schools, and during their studies both luminaire and luminous ceiling types of lighting were installed and tested. The RECORD reports here their findings.

To provide a satisfactory luminous environment for people who are doing close visual work, we need:

- (a) Enough light.
- (b) Glare-free light (requires a 3-to-1 brightness ratio).

## BANISHING GLARE, SHADOWS

The first requirement is obvious and needs no comment. The second deals with the fact that excessive contrasts in the visual field must be absent if eye-strain is to be eliminated. It is now generally realized that both glare and troublesome shadows are banished and a pleasing psychological effect is produced if the brightness of the brightest surface in the room does not exceed 3 times that of the work, and if the brightness of the work does not exceed 3 times that of the darkest surface in the room. This single criterion, as recommended by the Illuminating Engineering Society, provides the simplest rule for obtaining excellent quality in lighting.

As indicated in Table I, a 3:1 brightness ratio cannot be obtained when bare lamps are employed. It has been found that a 3:1 ratio requires a light source of very large area, which is obtained most effectively by using the entire ceiling. Evidently either a *reflecting* ceiling or a *transmitting* ceiling may be used for high-quality lighting. In the former, the ceiling is painted white and light is thrown onto it from below. In the latter,

a hung ceiling of translucent plastic is interposed between the lamps and the room.

## LIGHTING BY REFLECTION

Perhaps the simplest way of obtaining a luminous ceiling by reflection is to use

hanging luminaires that direct most of their light toward the ceiling. The parts of the luminaire that are visible from below should be made of a dense translucent material whose brightness is not widely different from the ceiling brightness. Several luminaires of this type are

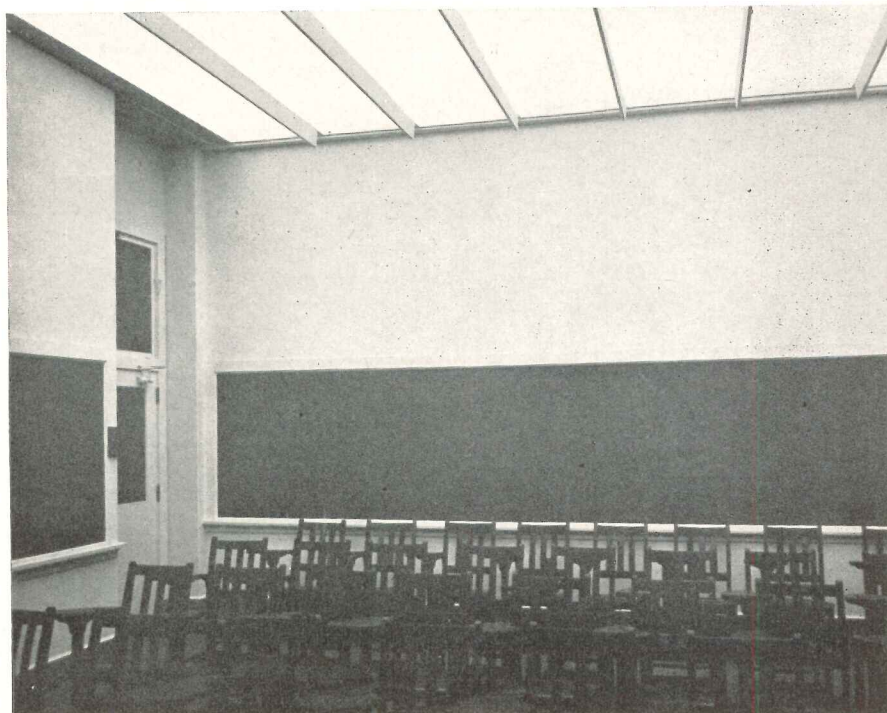
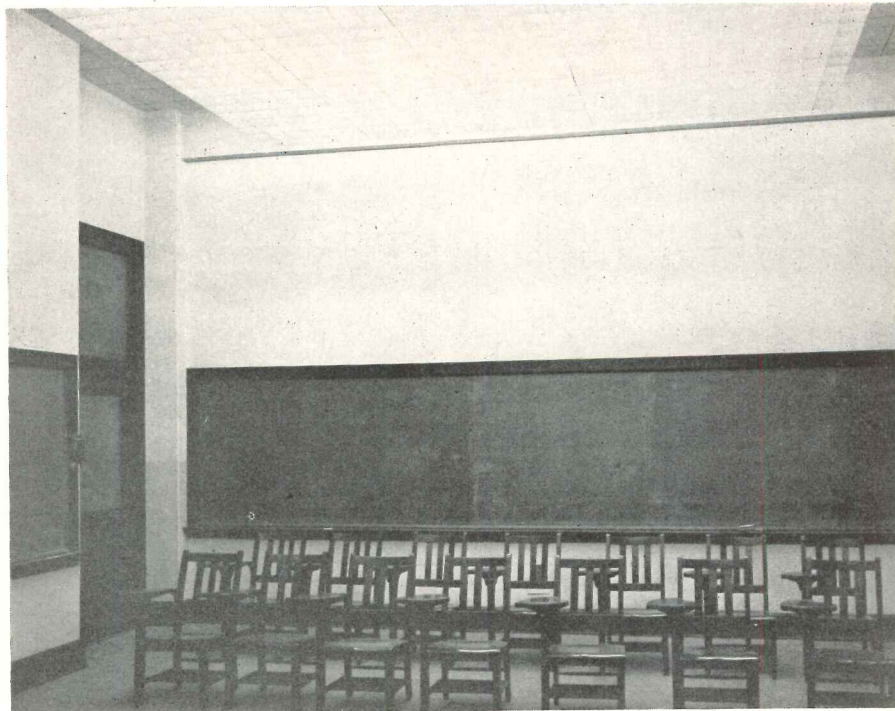

In studies evaluating modern lighting trends M.I.T. installed a louverall system (top) in one classroom and a ceiling of light diffusing plastic in another (bottom). Strips hanging below the plastic are for acoustic treatment. In new classrooms, lighter colored furniture, chalkboards would normally be used

**TABLE I**  
**Approximate Average Brightness of Some Fluorescent and Incandescent Lamps**

Lamp	Brightness (Blondel)*	Brightness Ratio**
40-watt, T-17, 4500° white fluorescent	9,900	24.7
40-watt, T-12, 4500° " "	17,300	43.3
96-inch, T-8 at 200 ma	17,700	44.2
at 300 ma	23,200	58.0
32-watt circular fluorescent	22,000	55.0
60-watt A-19 incandescent	70,000	175
100-watt A-21 "	120,000	300
200-watt PS-30 "	130,000	325
500-watt PS-40 "	200,000	500

\*1 blondel = 0.1 millilambert.

\*\* For illumination of 46.5 lumen per sq. ft. on white paper having a reflectance of 0.80.

now commercially available. An experimental luminaire, designed by the lighting committee, is shown in the photo at top of page 147. When used with highly reflecting room surfaces (ceiling at least 80 per cent, walls at least 50 per cent, floor and furniture at least 30 per cent) such luminaires satisfy the 3:1 criterion and provide an ideal luminous environment.

### TRANSMITTING CEILING

Another method of obtaining excellent visual conditions as studied by the lighting committee uses a hung ceiling of diffusing plastic. The bottom photo on page 145 shows a typical classroom lighted in this way. Forty-four 72-in. T-8 fluorescent lamps, spaced 24 inches apart, are mounted directly on the structural ceiling. The total load is 2200 watts or 3.26 watts per sq. ft. The average illumination at table level is approximately 60 lumens per sq. ft.

Approximately 18 in. below the true ceiling are perforated steel strips 6 in. deep, containing glass fiber absorbing pads which provide the acoustic treatment for the room. Without treatment, the reverberation time of the classroom was approximately 4 seconds, but this value was reduced to slightly more than

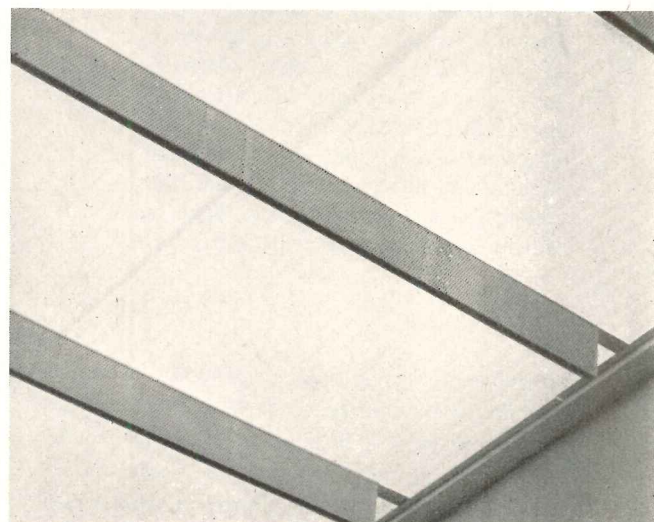
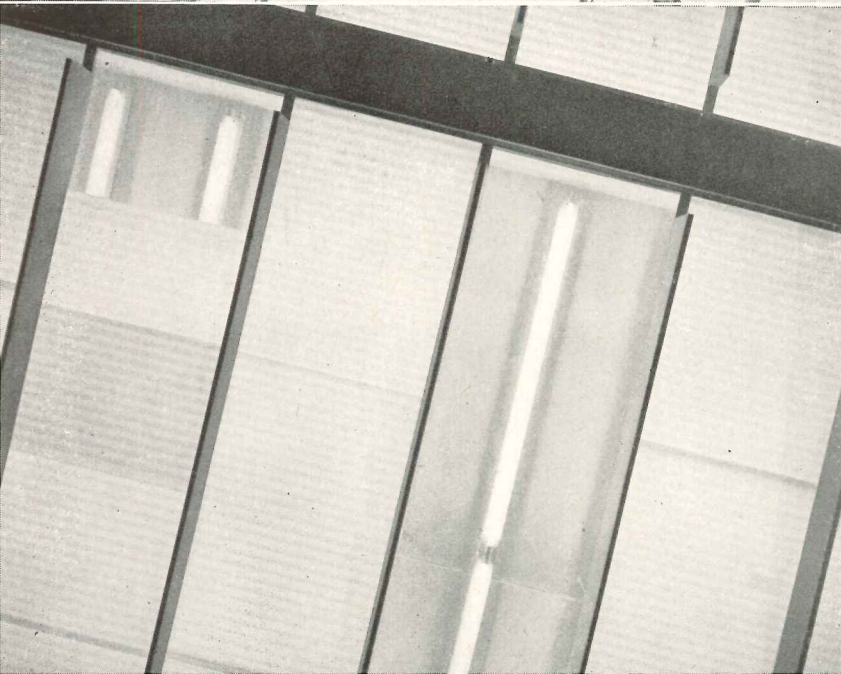
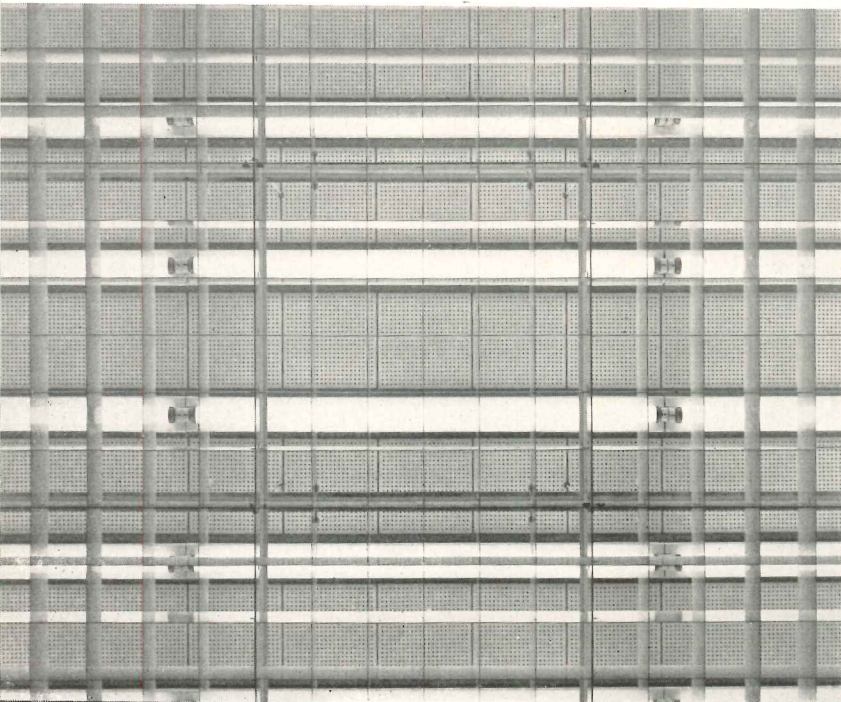

Top left: looking up at the louverall ceiling; fluorescent lamps are shown attached to acoustic tile. Bottom left: looking up at ceiling of light diffusing plastic; sheets can be pushed back for maintenance. Right: closeup of the perforated strips which provide acoustic control

1 second by the acoustic strips. Credit is due the M.I.T. Acoustics Laboratory which collaborated with the lighting committee on the acoustic design.

Above the acoustic strips are sheets of  $\frac{1}{8}$  in. light-diffusing plastic approximately 36 by 48 in. The sheets are corrugated for greater stiffness. They are easily moved to allow access to the lamps, as shown on opposite page.

As would be expected for a pioneer installation, the cost of lighting the room was rather high. Table II shows the total cost of lamps, ballasts, and wiring (done by local contractor).

How can these costs be reduced in future installations? With larger rooms, or several rooms installed at the same time, the labor cost per lamp would be lowered somewhat. Also, if the user is satisfied with less light, the number of lamps can be reduced proportionately.

The most promising item of economy, however, is the use of thinner sheets of the diffusing plastic which can be obtained for 60 cents per sq. ft. Or plastic-impregnated paper, costing about one cent per sq. ft. can be stretched on metal frames and can be easily renewed if it becomes damaged. It would seem that careful design might allow the transmitting luminous ceiling to be produced at a cost no greater than that of other high-quality lighting systems.

Because of the recent use of the louvered ceiling in a number of lighting installations, a direct comparison between it and the uniform luminous ceiling seemed advisable. Therefore, a louverall ceiling was installed in a classroom adjacent to that with the plastic

ceiling. Lighting was provided by 36, 40-watt T-17 "low-brightness" fluorescent lamps mounted on the ceiling. White enameled steel louvers with 45° cutoff were hung below the lamps. The total load was 1950 watts (2.88 watt per sq. ft.), and the average illumination at desk level was approximately the same as for the luminous plastic ceiling.

Though direct glare is usually cut out by the louvers, they have no effect on reflected glare which may be a very potent source of eyestrain. The photos at bottom this page show examples of reflected glare, experienced in the louver-all room but absent with the luminous plane ceiling.

The great defect of most lighting installations has been excessive brightness variation. The luminaires have been too bright, the floors and furniture have

been too dark. The modern trend is toward the use of lighter colors throughout the room, combined with large light-sources of low brightness. In this way, a 3:1 brightness ratio can be obtained, resulting in an ideal luminous environment.

TABLE II  
Cost of Installing an Experimental Luminous Ceiling

	Total Cost	Cost per sq. ft.
Lamps, ballasts, and wiring	\$1125	\$1.67
Acoustic beams, fabricated and installed	597	0.89
Diffusing plastic	968	1.43
<b>Total</b>	<b>\$2690</b>	<b>\$3.99</b>



Room using luminaires (upper left) designed by M.I.T. lighting committee. Each luminaire consists of two half cylinders, the upper one transparent plastic and the lower, diffusing plastic. The luminaires are of dust-tight construction, and no metal bars or other opaque parts are used on the sides

Demonstration of specular reflections from bare fluorescent lamps. Photos were taken in classroom with louvered ceiling

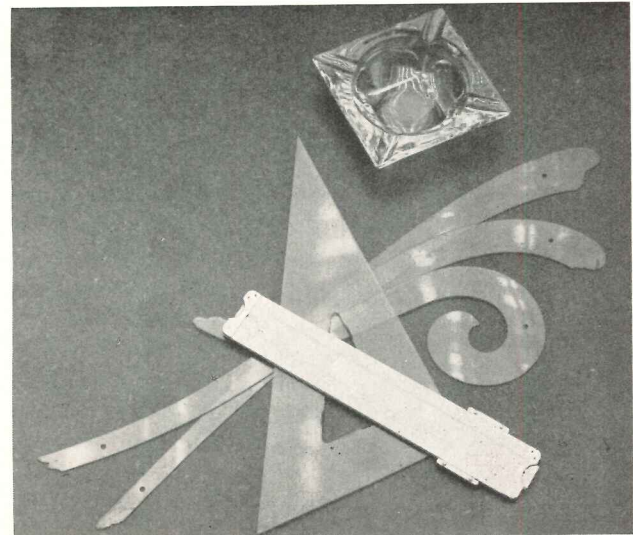
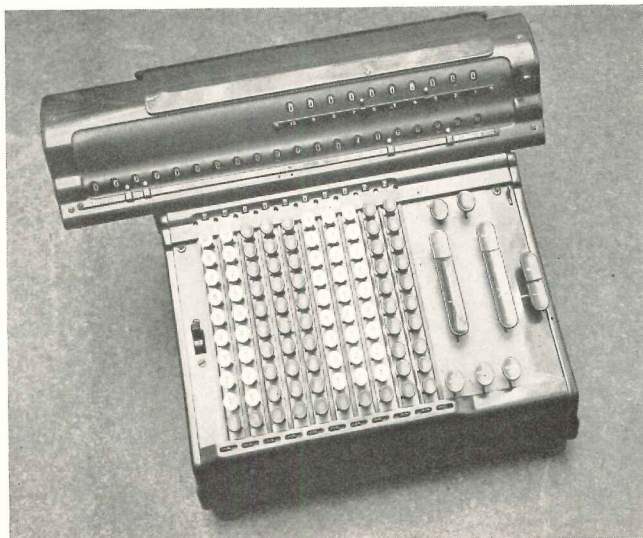

## PRODUCTS for Better Building

### CURTAIN WALL CONSTRUCTION

Curtain wall panels consisting of cellular glass insulation cores and concrete veneers are reported to lower costs, reduce construction time, provide lightweight construction, make more floor space available, and give permanent insulation. They have been fabricated in several practical sizes and thicknesses for use in basic curtain wall systems — spandrel (horizontal), vertical and bay filling — in single or multi-story construction.

The largest panels made to date measure 256 sq. ft. The popular thickness is 6 in. — 2-in. cellular glass core with 2-in. exterior and interior veneers.

The core is *PC Foamglas*, an inorganic, closed-celled, rigid cellular glass insulation, said to be completely impervious to water and vapor, thus stopping moisture vapor migration from one side of the panel wall to the other. There are said to be no "cold spots" in the walls.

Concrete veneers, processed by heavy mechanical troweling, steam curing, and/or vacuum processing, are said to have good weathering characteristics. Exterior and interior faces of the insulated concrete panel require no additional finish, unless desired.

Glass block fenestration has been cast in while panels are being fabricated horizontally in edge forms. A 24-hr. casting-to-lifting schedule has been reported used successfully. Panels can be made on the site or fabricated some distance away and shipped by rail or truck.

The insulated concrete panel wall is described as being adaptable to any design, regardless of floor plan, window arrangement, or structural skeleton.

The 6-in. thick panel weighs from 40 to 60 lb. per sq. ft., depending on the aggregate used. Thinness of the panels increases usable floor area about 72 in. for each running foot of floor perimeter, according to the manufacturer. Final installed cost for jobs to date is reported to be under \$2.00 per sq. ft. of exterior surface. Pittsburgh Corning Corp., 307 Fourth Ave., Pittsburgh, Pa.

### HOSPITAL FOOD CONVEYOR

The development of a new *Selective Menu Food Conveyor* for hospitals is reported to be a real aid for diet therapy programs.

The conveyor has a flexible top deck arrangement which utilizes interchangeable square and rectangular utensils instead of only regular round-well utensils. Eighteen utensils in six sizes come with each conveyor, permitting a great number of top-deck arrangements. There are two round wells for liquid food.

To speed the distribution of food, there is a long side shelf with room for two complete trays. Two heated drawers provide for special diets and rolls.

The top deck is of one-piece, crevice-free construction, the wells being an integral part of the top, making it much easier to clean. The body is also of one-piece, seamless construction. The conveyors are built from heavy-gauge stain-

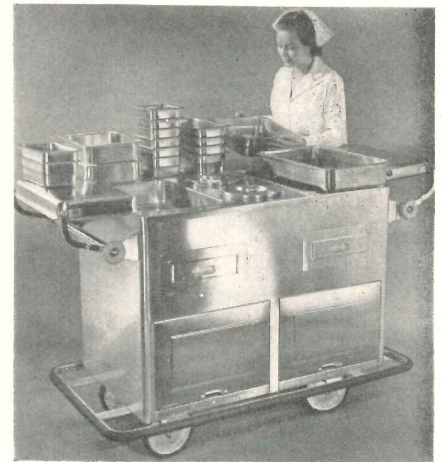

Hospital food conveyor, made of seamless stainless steel, has flexible top deck

less steel. S. Blickman, Inc. 534 Gregory Ave., Weehawken, N. J.

### SIX BOILERS IN ONE HOUSE

Probably one of the largest and most unique residential heating systems installed in recent years is in use in the Harry L. Magee residence, Bloomsburg, Pa. No less than six *H. B. Smith* boilers are used to provide space heating and domestic hot water. Two boilers furnish hot water for the radiant system of the main house, two warm swimming pool water and the other two provide domestic hot water to the house and garage.

Radiant heating is provided by copper tubes imbedded in the ceiling plaster. And in conjunction with this system there are a winter humidifying and air circulation system and a summer air conditioning used in the main house.

(Continued on page 184)

Lightweight, insulated panels made with a core of cellular glass covered by concrete veneers. Left photo shows core being inserted

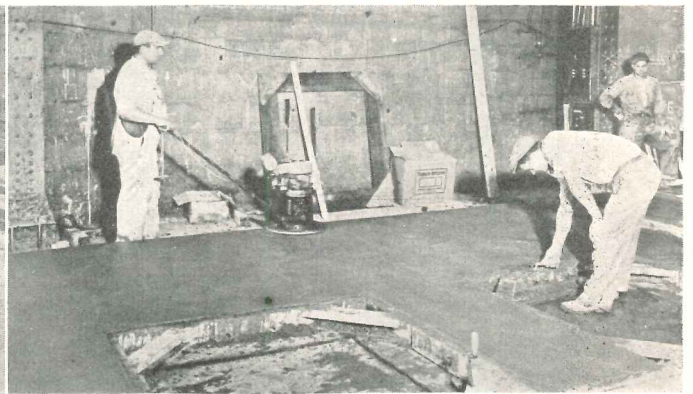
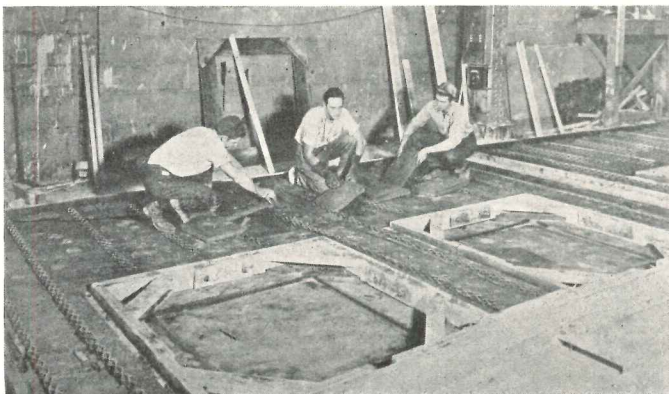



EACH OF THE 1000 HOMES in the Richland, Washington, Housing Project has aluminum heating ducts throughout. Central

Service Company, Seattle, is the builder, J. Fletcher Lankton-John N. Ziegele, Peoria, Ill., Architects and Engineers.

## Aluminum ducts cut installation and fuel costs in 1000 home project!

**HERE'S HOW:** Thanks mainly to reduced surface radiation loss, 5 to 30 per cent *more* heat is delivered through ducts of Kaiser Aluminum than through ducts of other materials—even though initial air temperatures are identical!

Result: Installation savings are possible through elimination of insulation. And fuel consumption is cut because of lower required B.T.U. input.

These facts were proved in tests made by Aladdin Heating Corporation, Oakland, under the direction of a Professor of Mechanical Engineering and a Research Engineer of a

major U. S. university. (Name of school on request.)

On the left, below, is a graph showing results of their tests. Note that new, bare Kaiser Aluminum is even more efficient than a far more costly material! And that *aged*, bare Kaiser Aluminum delivers only slightly less heat than the costlier material!

What's more, ducts made of Kaiser Aluminum are light, easy to handle, yet *tough*. During installation they mean less worker fatigue, less wear on shop equipment, fewer steps in handling. On *your* next job, specify ducts of Kaiser Aluminum!

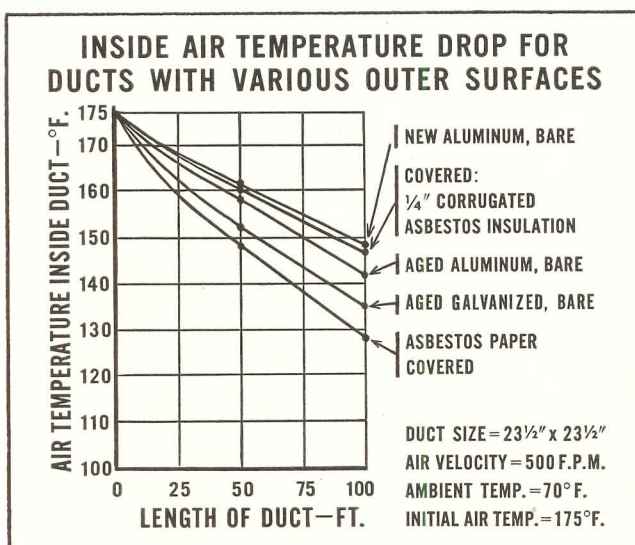

THIS COMPARISON of duct materials proves why you should choose Kaiser Aluminum for all heating system ductwork!

### Permanente Metals

PRODUCER OF

# Kaiser Aluminum

**NEW! FREE BOOKLET** with complete specifications to show you how you can cut duct installation costs and offer clients lower fuel costs with Kaiser Aluminum. Write for "New Conceptions in Ductwork." Consumer Service Dept. AR-6, Permanente Products Company, Kaiser Building, Oakland 12, California.

NAME \_\_\_\_\_ TITLE \_\_\_\_\_

FIRM \_\_\_\_\_

ADDRESS \_\_\_\_\_

CITY \_\_\_\_\_ STATE \_\_\_\_\_

Permanente Products Company, Kaiser Building, Oakland 12, Calif. • Sales Offices and Warehouse Distributors in principal cities.

Copyright, 1949, Permanente Metals Corp.

**IN HEATING, TOO★**

*"It's Smart to be Thrifty"*

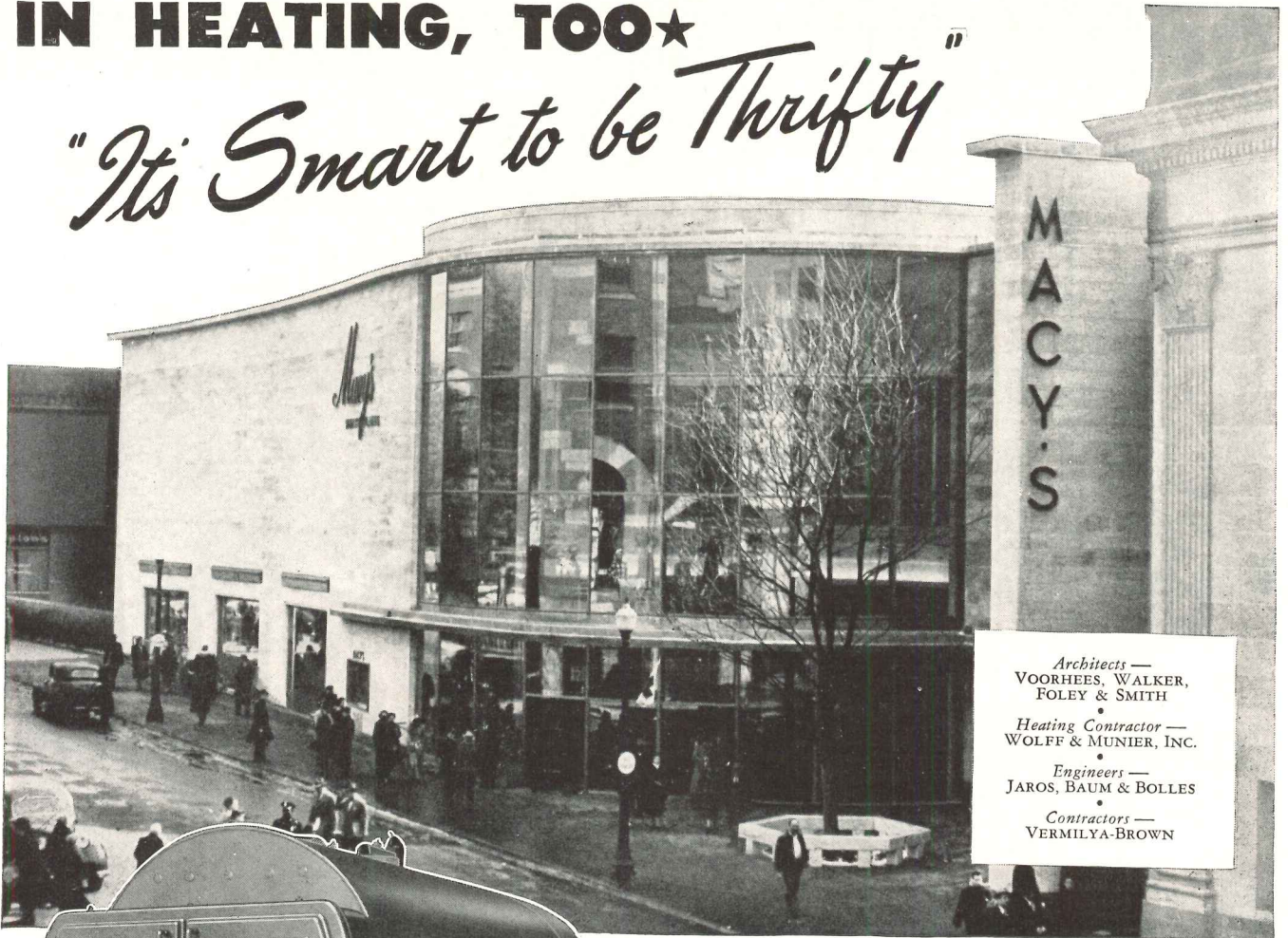

*Architects —*  
 VOORHEES, WALKER,  
 FOLEY & SMITH  
 •  
*Heating Contractor —*  
 WOLFF & MUNIER, INC.  
 •  
*Engineers —*  
 JAROS, BAUM & BOLLES  
 •  
*Contractors —*  
 VERMILYA-BROWN

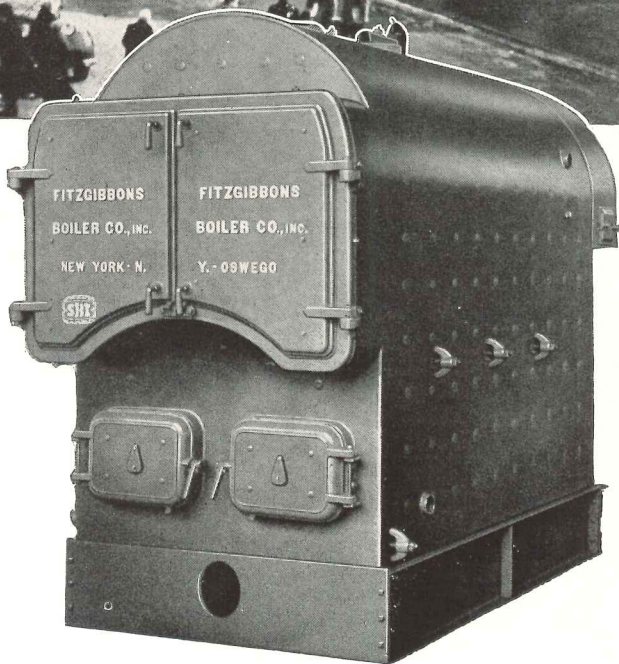

**FITZGIBBONS  
 "D" TYPE STEEL BOILER**

*Available for oil, gas, stoker or hand fired anthracite, in sizes from 2680 to 42500 sq. ft. EDR steam. A.S.M.E. code built, Hartford Insurance inspected, hydrostatically tested, S.B.I. rated.*

**The beautiful new Macy's★  
 White Plains store**, recently opened, is heated by three fuel-saving Fitzgibbons "D" Type steel boilers, thus carrying out the principle of thrift expressed in Macy's famous slogan.

Fitzgibbons quick steaming, rapid circulation and ideally designed combustion area, and Fitzgibbons low cost maintenance, will all do their part to hold down overhead in this modern store.

There are good reasons why architects and engineers specify Fitzgibbons "D" Type steel boilers in so many commercial, office and apartment buildings, hotels, hospitals, and institutional edifices. The "D" Type Catalog gives the story in detail.

Write for a copy.



**Fitzgibbons Boiler Company, Inc.**

General Offices: 101 PARK AVENUE, NEW YORK 17, N. Y.  
 Manufactured at: OSWEGO, N. Y. • Branches in Principal Cities



## CABINETWORK DETAILS

See also May 1949 issue (pages 147, 153, 155)

Based on information from Nuroco Woodwork, New Rochelle, N. Y.

### PANELING

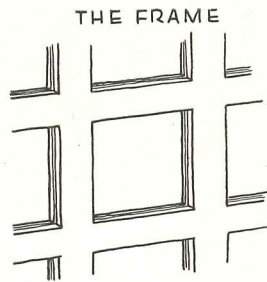

THE FRAME

THE FRAME MUST BE RIGID. PANELS FLOAT FREE, THEIR EDGES HELD IN GROOVES IN THE FRAME.

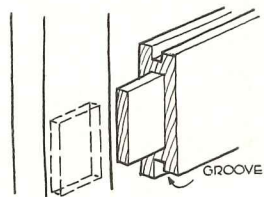

RAILS AND STILES ARE MORTISED. GROOVES RECEIVE SPLINES OR PANEL EDGES.

### PANEL TYPES

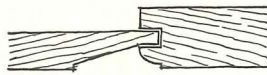

SOLID STICKING PANEL - MAY BE USED IN EITHER SOLID OR PLYWOOD PANELS. USUAL PANEL CONSTRUCTION.

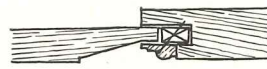

PANELS MAY ALSO BE SECURED BY MEANS OF APPLIED MOLDINGS, NAILED INTO WOOD SPLINES SLIPPED INTO GROOVES OF STILES AND RAILS. (IT COSTS LESS TO CUT GROOVES AND INSERT SPLINES THAN TO MAKE COMPLEX PROFILE WITH SPLINES INTEGRAL IN THE STILES).



LEAST EXPENSIVE METHOD - USED WHERE BACK OF PANEL IS NOT EXPOSED.

### TRUE PANELING (IN WHICH PANEL IS SET FREE IN A FRAME)

#### THE PANEL

THE PANEL IS MADE OF SOLID WOOD - ONE PIECE,

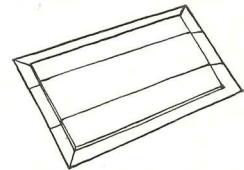

OR OF SEVERAL MATCHED PIECES GLUED TOGETHER,

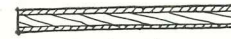

OR OF PLYWOOD,



OR OF VENEERED CORE.

THE ADVANTAGE OF PLYWOOD PANELS IS THAT THEY PERMIT PERFECT MATCHING OF COLOR AND GRAIN IN ALL PANELS. PLYWOOD, TOO, EXPANDS AND CONTRACTS LESS THAN SOLID WOODS. DISADVANTAGE IS THAT PLYWOOD PANELS ARE DIFFICULT TO BEVEL. WHERE BEVELING IS REQUIRED, HERE ARE SOLUTIONS:



USES SOLID WOOD FOR BEVEL; CALLS FOR CAREFUL MATCHING OF PLYWOOD IF PANEL IS TO BE NATURALLY FINISHED.

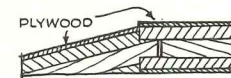

USES STRIPS FROM SAME PLYWOOD PANEL TO ACHIEVE PERFECT MATCH. SUPERIOR TO ABOVE; MAY BE COSTLIER.

### WARDROBE AND CABINET DOORS

#### I. PLYWOOD FLUSH DOORS

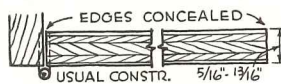

EDGES CONCEALED

USUAL CONSTR. 5/16" - 13/16"

LEAST EXPENSIVE FLUSH DOOR. SELECT FOR UNIFORMITY OF GRAIN, PATTERN (IF NATURALLY FINISHED), GOOD CRUMBLE-FREE CORE. FOR METHODS OF TREATING EXPOSED PLYWOOD EDGES SEE "PLYWOOD EDGE TRIMMING."

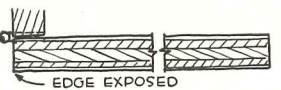

EDGE EXPOSED

CAN BE USED ONLY AT CORNERS. - PRODUCES SIMPLE MODERN EFFECT.

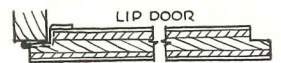

LIP DOOR

PRODUCES RAISED PANEL EFFECT, ESPECIALLY STRIKING WHEN MANY LIKE-SIZED PANELS ARE USED.

#### II. PANEL DOORS



USUAL CONSTRUCTION - USED WITH SOLID OR PLYWOOD PANELS.



BACK NAILING STRIP

BACK STRIP IS USED MAINLY TO SECURE GLASS PANELS. MAY ALSO BE USED TO SECURE WOOD PANELS IN SAME DOOR.

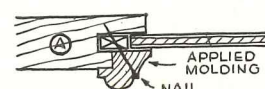

APPLIED MOLDING  
NAIL

APPLIED MOLDINGS ARE USED WHERE SHAPE OF MOLDING MAKES CUTTING IT FROM STILE WASTEFUL (A), OR WHERE PROFILE OF MOLDING PRECLUDES USE OF COPING AT CORNERS (B), OR WHERE MORE THAN ONE MOLDING DESIGN MAY BE USED IN A DOOR.



NAIL

### WARDROBES AND CABINETS

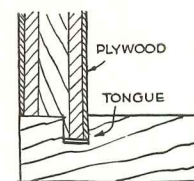

PLYWOOD

TONGUE

TYPICAL GOOD OUTSIDE CORNER CONSTRUCTION WHERE SOLID MEMBER FORMS WARDROBE DOOR FRAME.

SOLID MEMBER

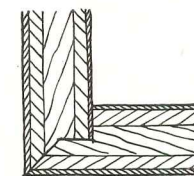

GOOD OUTSIDE CORNER CONSTRUCTION WHERE NATURAL FINISH CONTINUES AROUND CORNER. RECOMMENDED WHERE BOTH MEMBERS ARE PLYWOOD. COSTLIER.

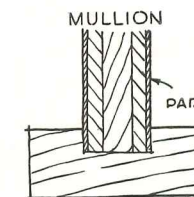

MULLION

PARTITION

GOOD MULLION CONSTRUCTION FOR WARDROBES AND OTHER CABINETS. PARTITION OF 3/4" PLYWOOD IS LET INTO MULLION.

(Continued on page 153)

A striking use of Zourite as trim by  
Robert Kaplan, Architect, New York City.

**ALUMINUM**

# Zourite

**the Modern Material  
for all facing jobs**



**In alumilite finish or in green,  
brown, and black porcelain enamel**

Handsome, durable Zourite is the outstanding modern material for facing facades, walls, ceilings, trim areas, and other exterior and interior surfaces. It is ideal for new construction or remodeling, for commercial, institutional, and industrial buildings.

Made of easy-to-handle aluminum, Zourite can be applied to masonry, wood, and metal surfaces, and it can be fitted around corners, angles, and curves. Shipped complete with attachment clips, strips, and trim members, it comes in 8½-inch and 4¼-inch widths. Remodeling with Zourite requires practically no job preparation—it can be applied to existing surfaces.

In natural alumilite finish or in porcelain enamel, Zourite does not chip or scale. It is washed clean with water. Write for information. 219 North Front St., Niles, Mich.; 2519 8th St., Berkeley, Cal.; 817 East Third St., Lexington, Ky.

THE  
**Kawneer**  
COMPANY

Store Front Metals • Modern Entrances • Facing Materials  
Aluminum Louvered Ceilings • Aluminum Roll-Type Awnings

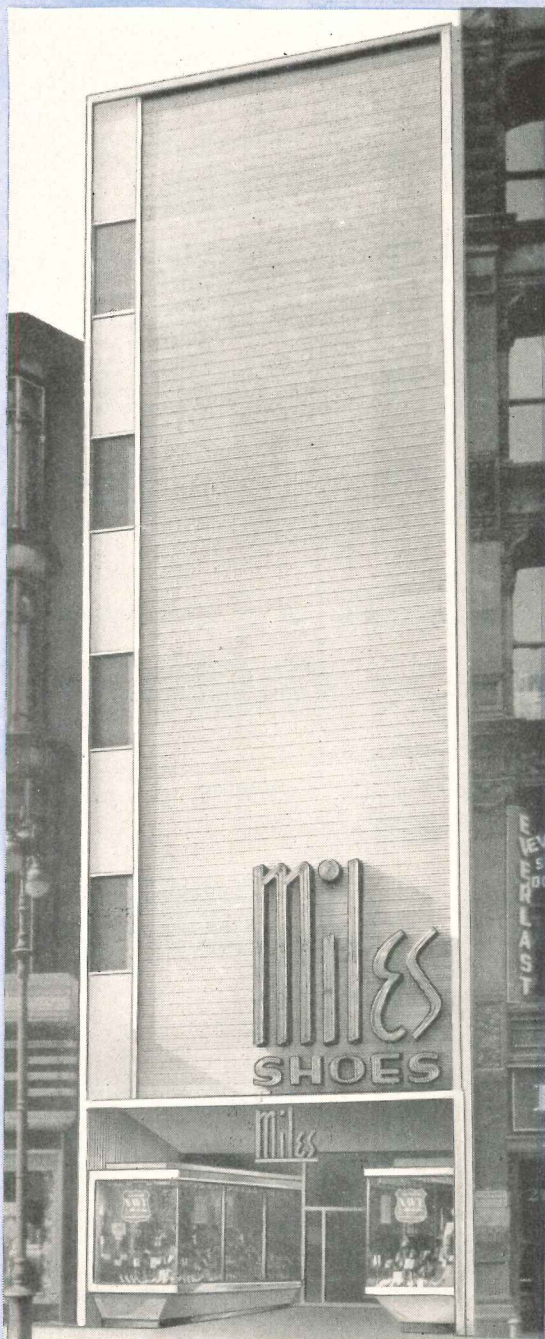

Zourite used horizontally by  
Vincent Furno, Architect, New York City.



An interior application of Zourite by  
Pearson and Tittle, Architects, Montgomery, Ala.



## CABINETWORK DETAILS

See also May 1949 issue (pages 147, 153, 155)

Based on information from Nuroco Woodwork, New Rochelle, N. Y.

(Continued from page 151)

### PLYWOOD EDGE TRIMMING



MOST COMMON SOLUTION - REQUIRES EXPENSIVE CUTTING, GLUING. CORNERS ARE WEAK. GOOD WHEN ALL SIDES ARE EXPOSED.

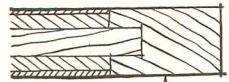

THIS PIECE MAY BE MOLDED

PROVIDES STRONG EDGE FOR HINGES, ABRASIVE WEAR, OR MOLDED WORK. INTRODUCES DIFFERENT WOOD GRAIN AND TEXTURE.

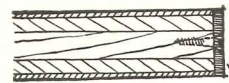

METAL EDGE

PROVIDES STRONG, WEAR-RESISTANT EDGE FOR WORK TOPS AND TABLES. TYPE SHOWN IS FLEXIBLE - CAN BE BENT TO FOLLOW MOST CURVES. FOR GOOD SEAL STRIP, SHOULD BE CEMENTED AND SCREWED TO THE TOP. USED MOSTLY FOR SERVICE TOPS.

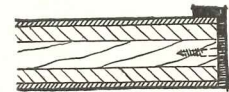

METAL

TOP LIP HOLDS DOWN TOP VENEER - MAKES STRONGER, MORE DURABLE EDGE. WILL NOT BEND READILY.

### UNTRIMMED EDGES

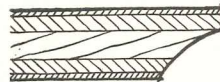

THIS CORNER TENDS TO BE WEAK. RECEDED EDGE HELPS CONCEAL EXPOSED EDGES OF PLYS.

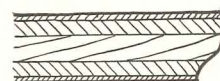

STRONGER AT TOP. CURVED EDGE HELPS CONCEAL EDGES OF PLYS.

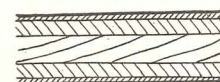

IF SURFACE IS TO BE PAINTED, NO EDGE FINISH IS NECESSARY.

### TABLE LEGS, APRONS METHODS OF ATTACHING TOPS TO LEGS

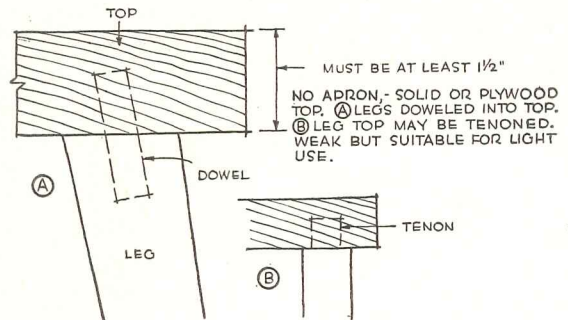

MUST BE AT LEAST 1/2"

NO APRON - SOLID OR PLYWOOD TOP. (A) LEGS DOWELED INTO TOP. (B) LEG TOP MAY BE TENONED. WEAK BUT SUITABLE FOR LIGHT USE.

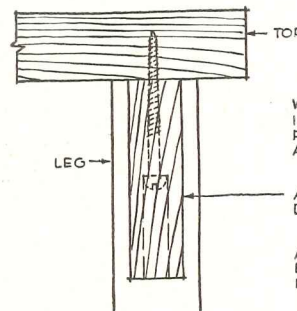

WITH APRON - APRON SCREWED INTO TOP, MORTISED INTO LEG. FOR EXTRA STRENGTH, BRACE APRON AT SIDES AND CORNERS.

APRON (MORTISED OR DOWELED INTO LEG)

ALTERNATE: APRON MAY ALSO BE DOWELED OR RABBETED INTO TOP.

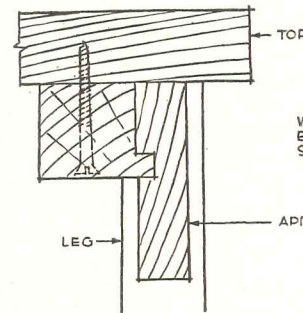

WITH APRON - STRONGEST TYPE, BLOCK RABBETED INTO APRON. SELDOM USED.

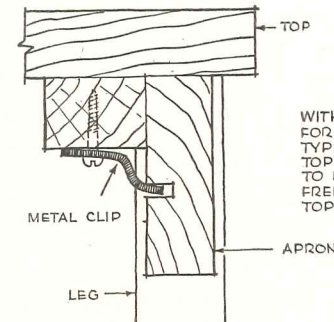

WITH APRON - METAL CLIP USED FOR LONG SOLID TOPS - AS SOME TYPES OF COUNTERTOPS, WORK TOPS. GROOVE ALLOWS TOP TO EXPAND AND CONTRACT FREELY. (NOT REQUIRED WHEN TOP IS OF PLYWOOD)

## MANUFACTURERS' LITERATURE

### Glass Insulation

*PC Foamglas For Home Insulation.* Covers uses of cellular glass insulation for floors, masonry walls, roofs, and in snow melting systems for sidewalks and driveways. Introduction points up special qualities of the insulation which is said to resist passage of moisture or moisture vapor, and to be non-combustible, rot-proof, warp-proof. Specifications are given for insulation of: ground and foundation walls; masonry walls (including application procedures, materials and finishes); roofs (including application procedures); snow melting coils. Physical properties are listed. 12 pp., illus. Pittsburgh Corning Corp., 307 Fourth Ave., Pittsburgh 22, Pa.\*

### Detention Screens

*Detention, Protection and Safety Screens.* Folder on screens for detention and protection applications in psychiatric hospitals or wards, and safety screens to provide protection for children or elderly cases. Exclusive features are pictured and described. 4 pp., illus. Chamberlin Detention Screens, 1254 La Brosse St., Detroit 26, Mich.

### Light and Color

*Color is How You Light It.* Presents results of a study on the effect of artificial light on color, providing a simple method of determining the suitability of six different tones of white light on colors of paints and fabrics. A two page chart is included which shows the appearance of 44 decorating colors under each of six artificial light sources (fluorescent and incandescent). The first part of the booklet deals with the nature of light and color, definitions of color and light terms, the science of seeing, color systems, psychology of color, color matching and color harmony. 14 pp., illus. Sylvania Electric Products, Inc., Commercial Engr. Dept., 500 Fifth Ave., New York, N. Y.\*

### Wood

*Finishing Northern Hard Maple Flooring the MFMA Way.* Folder on the prime requirements for good service finishing and proper maintenance of

northern hard maple, beech and birch flooring. Includes information on the sanding procedure for a smooth floor, tips on the application of finishes, and suggestions for surface cleaning. Maple Flooring Manufacturers Assn., Oshkosh 9, Wis.\*

### Use of Gas in the Home

*The Reference Manual of Modern Gas Service.* Comprehensive manual on installation practices, specifications, appliances and sizing of gas equipment. It provides answers to questions on kitchen planning, gas cooking, gas refrigeration, basements and utility rooms, the modern home laundry, piping, and chimneys, flues, vents. Standardized data sheets are provided on the newest gas appliances. The manual has a loose-leaf binding so that supplementary material can be added. 250 pp. plus manufacturers' data sheets. American Gas Assn., 420 Lexington Ave., New York 17, N. Y. \$7.50.

### Kitchen Equipment

*Plan-It (Cabinet Storage Issue).* The current issue of the Plan-It bulletin, published by Hotpoint, Inc., is devoted to the problem of how much cabinet space is needed for kitchens based on findings of the Small Homes Council and Agricultural Experiment Station of the University of Illinois. Ample and minimum space requirements for liberal and limited kitchen supplies are reported. Hotpoint, Inc., 5600 W. Taylor St., Chicago 44, Ill.\*

*Blueprint for Better Kitchens.* Gives specifications and dimensions of a complete line of base and wall cabinets and cabinet sinks. Typical kitchen installations are illustrated in color. Special features of the cabinet sinks, including an electric garbage disposer, are described. 12 pp., illus. Mullins Mfg. Co., Warren, Ohio.\*

### Intercommunicating Systems

*Intercommunicating Telephone Systems (Bulletin No. 155).* Describes function, operation, capacity, styles of instruments, equipment required, and wiring and power supply for a variety of intercommunicating telephone systems.

Wiring diagrams are included. 20 pp., illus. Auth Electric Co., Inc., 34-20 45th St., Long Island City 1, N. Y.

### Lightweight Aggregate

*Permalite, The New Insulating Plaster Aggregate.* Technical data, specifications, instructions for use, and other allied information on a lightweight plaster aggregate material made from perlite, a volcanic rock. Discusses manufacturing methods, ore deposits and production facilities. The material is now being processed in Torrance, California, and will soon be available from Linden, N. J. 6 pp., illus. Great Lakes Carbon Corp., Building Products Division, 18 E. 48th St., New York 17, N. Y.

### Lighting

*It Happened in Denver's Schools — It Can Happen in Yours.* Report on how new lighting systems were installed in 80 Denver public school buildings. Tells how the project was planned, how classrooms were redecorated, how fixtures were selected. 16 pp., illus. Day-Brite Lighting, Inc., School Lighting Division, 5450 Bulwer Ave., St. Louis 7, Mo.\*

### Access Panels

*Access Panels by Watson.* Shows how access panels can be installed quickly in metal lath, wood lath, marble, tile and plastered openings. The standard size panels are designed to provide instant, convenient access to control points vital in the maintenance of plumbing, heating and ventilating, air conditioning and refrigeration systems. Installation drawings and a list of standard sizes are included. 4 pp., illus. Watson Mfg. Co., Inc., Jamestown 1, N. Y.\*

### Plant Maintenance

*The Tornado Method.* Covers many problems of plant and institution floor care and maintenance. Describes equipment necessary, steps to be followed with both old and new floors, and includes a stain removal chart. Specific instructions are given for all types of floors. Describes necessary equipment and accessories. 34 pp., illus. Breuer Electric Mfg. Co., 5100 Ravenswood Ave., Chicago 40, Ill.

### Glazing Hints

*Facts About Glazing.* Brings out important points in applying glazing compounds to wood or metal sash. Takes

(Continued on page 206)

\* Other product information in Sweet's File, 1949.



## IT'S SAFETY-SET FOR SELLEVISION and Sellevision Moves the Goods

**S**ALES INSIGHT marks the keen merchandiser and *Sellevision*\* literally means more sales in-sight. The store front that has it holds old customers and attracts new ones. It's *selling power* brought to the front and built right into it.

ABOVE ▲ *Borg Flower & Gift Shop, Chicago. Thermopane installed in Brasco Anodized Aluminum Settings.*

Architect:  
*Glenn Q. Johnson  
Park Ridge, Illinois*

*Sellevision* is particularly effective when complete Brasco metal settings are utilized. Our widely adaptable Safety-Set Store Front Construction provides metal sections substantially reduced in size to reveal the largest possible unobstructed glass surfaces. At the same time we maintain the deeper, safer, more uniform grip on the glass which has always typified Brasco sash.

Our details show how this is accomplished and also indicate the use of millwork in standard stock sizes only, making Safety-Set most economical to install. Here is sound, practical, handsome construction . . . painstakingly fabricated in both heavy gauge stainless steel and anodized aluminum. Catalog and comprehensive full size details mailed promptly on request.

\*©

★ ★ A COMPLETE LINE FOR EVERY DESIGN ★ ★

**Brasco**  
SAFETY-SET  
STORE FRONTS

**BRASCO MANUFACTURING CO.**  
HARVEY • (Chicago Suburb) • ILLINOIS

Specialists in Metal Store Front Construction for more than 35 Years

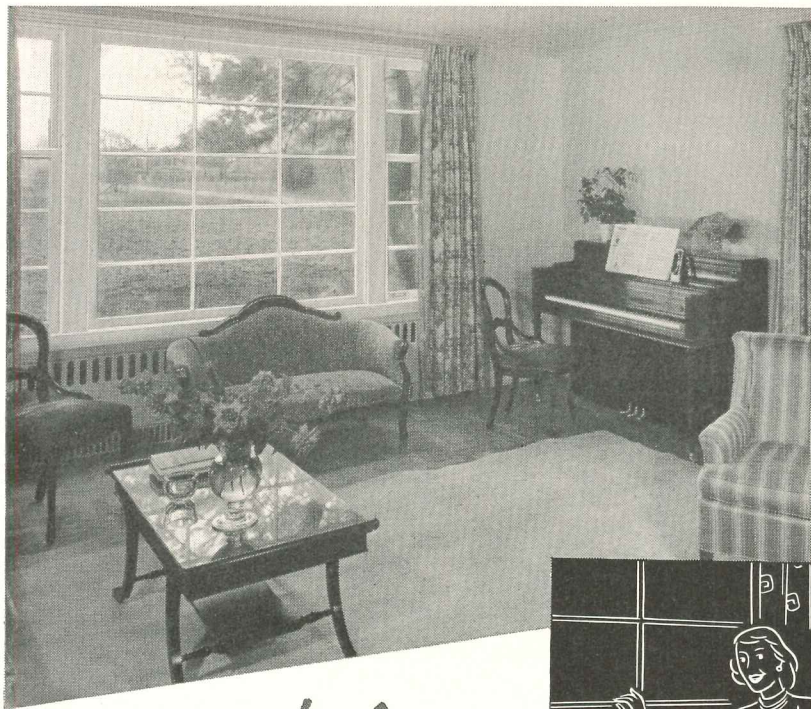

You can *feel*  
the difference



When you choose these *Wood Windows*

Feeling is believing . . . and that's a major reason why Ponderosa Pine windows are so widely preferred. For these windows *feel* more comfortable . . . they have the warmth of wood, a natural insulating material. In addition, because wood does not readily transmit cold, it does not encourage condensation—a frequent cause of redecorating problems.

Ponderosa Pine is a high quality wood—yet Ponderosa Pine woodwork is moderate in cost. Even grained, smooth in texture and low in density, it takes paint or other finishes without “grain raising” and holds them lastingly. In accordance with high industry standards, Ponderosa Pine windows are available toxic preservative treated at the factory—an additional safeguard against moisture, decay or insect attack. And Ponderosa Pine windows and doors offer you a wide scope of choice, because they are made in many styles to fit any style of architecture.

for friendly living

*Ponderosa Pine*  
**WOODWORK**



Mail the coupon for your copy of “Today’s Idea House”—a 32-page booklet full of photographs and useful information about Ponderosa Pine windows, doors and frames.

Ponderosa Pine Woodwork  
Dept. SAR-6, 38 South Dearborn Street  
Chicago 3, Illinois

Please send me a copy of “Today’s Idea House.” (Please print)

Name.....

Address.....

City.....Zone.....State.....

## NEWS FROM CANADA

(Continued from page 10)

### Labor Productivity Still Low

One out of every 13 non-farm workers in 1948 was employed in the construction industry, Central Mortgage & Housing Corporation reports in the current issue of “Housing in Canada,” a quarterly summary of major trends in the housing field. On the whole, construction employment averaged about 289,000 during the year, an increase of 37,000 over 1947, itself a peak employment year.

Although 1948 saw some improvement, “Housing in Canada” states that the present man-hour output of building labor is lower than in 1939. This it attributed to a thinning in the labor ranks of skilled construction workers and the delays and uncertainties of material deliveries owing to certain shortages. While the combined index of residential material prices and construction labor wage rates was 97 per cent higher in 1948 than 1939, it is reported that actual on-site costs were 108 to 118 per cent higher.

### Advice From Senior Architect

Opportunities for architects are many, says A. S. Mathers, F.R.A.I.C., R.C.A., writing in the Financial Post. The article is one of a series designed to help young Canadians decide the all-important question of their future.

Mr. Mathers, a partner in the well-known Toronto firm of Mathers & Haldenby, expresses the opinion that “Mentally a successful architect should be alert and imaginative. He should be observant and possess a pleasing personality and be able to get along well with all sorts of people.”

Mr. Mathers thinks that the best training for an architect is a combination of formal academic study and practical experience on construction work, both in an architect’s office and in the field. Equally essential is familiarity with the administrative end of architectural practice. Postgraduate work, to his mind, is not nearly so important as travel. He warns the young architect not to marry too early. “Many brilliant young men,” he says, “have denied themselves the possibility of later success by assuming the financial burden and restrictions on travel imposed by marriage before their earning power was sufficient.

(Continued on page 158)

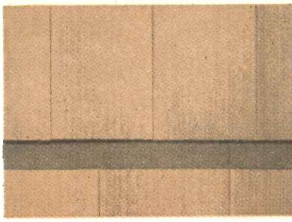

Customers have a choice of smooth-surfaced stained shingles with visible joints or

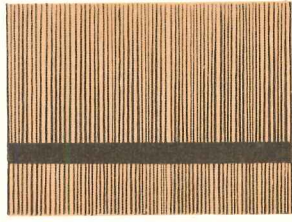

Grooved surfaced shakes which have invisible joints and resemble handplits.

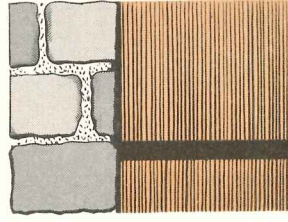

They are excellent for use with other building materials.



Application is easy as ABC. Ship-lap nailing guide is the only "extra" tool needed.

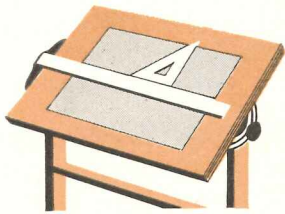

Easy to specify, the complete specification range is covered in Sweet's 8b/7a.

## 14 reasons why Architects specify STAINED SHINGLES and SHAKES

Beauty and versatile application to design are primary reasons for the growing trend to stained shingles and shakes for residence walls. Whether the design calls for shingles or shakes—you have the freedom to specify exposures as narrow as 8", as wide as 16", or any appropriate exposure between these extremes. Full specifications and recommendations are included in Sweet's Architectural File 8b/7a.

Note the other advantages illustrated on this page, particularly the ease of application, good nation-wide distribution and plentiful supply. Manufacturers listed below will send sample shingle and shake products to interested architects on request.

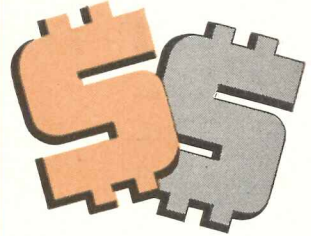

Homeowners get greater value, dollar for dollar, with stained shingle and shake sidewalls.



Carton packages make stained shingles and shakes easy to store, clean to handle, easy to deliver.



Distribution is convenient to dealers everywhere. Write to manufacturers listed below.

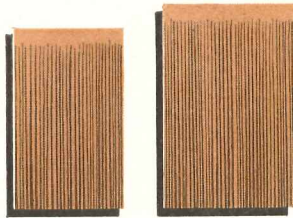

16" and 18" lengths provide wide choice of weather exposures to make project homes look different.

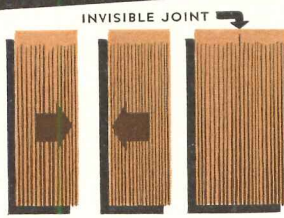

Edges of shakes are true parallel. Joints are tight and blend with the grooved texture.



Every shingle and shake home is an advertisement. One home will lead to the sale of another.



Architects approve and recommend cedar shingles and shakes. Sweet's file has 8 pages of data.

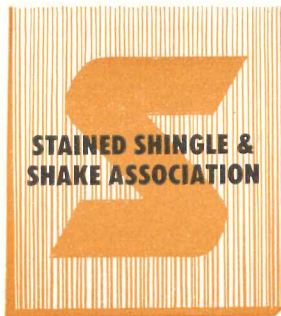

### ASSURANCE OF QUALITY

Rigid grading requirements for the manufacture of stained shingles and shakes have been established by the Stained Shingle and Shake Association. Precision re-butting and jointing, proper drying and packing, minimum widths, and guaranteed coverage per square are maintained by the members of the Association. Address inquiries to the Association at 835 Central Building, Seattle 4, Washington, or write direct to any member listed below.

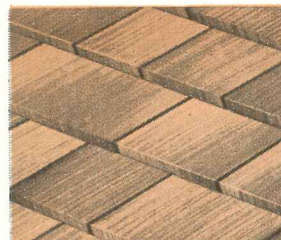

Stained shingles are excellent material for roofs as well as for sidewalls. A real roof value.

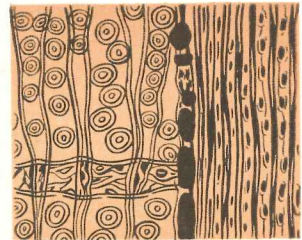

Cedar shingles and shakes have millions of microscopic insulating cells to resist heat transmission.

### ASSOCIATED MANUFACTURERS

- Creo-Dipt Company, Inc., North Tonawanda, New York • Everett Shingle & Shake Company, Everett, Washington • Capilano Timber Company, Ltd., Vancouver, British Columbia • Perma-Products Company, Cleveland, Ohio • West Coast Stained Shingle Co., Seattle, Washington • Portland Shingle Company, Portland, Oregon • Wood Beautifiers, Seattle, Washington • Colonial Cedar Co., Inc., Seattle, Washington • M. R. Smith Lumber & Shingle Co., Seattle, Washington • Canadian Forest Products, Ltd., Vancouver, British Columbia • The Robert McNair Shingle Co., Ltd., Vancouver, British Columbia

# WEISART

## Flush Compartments in any desired color for finest buildings

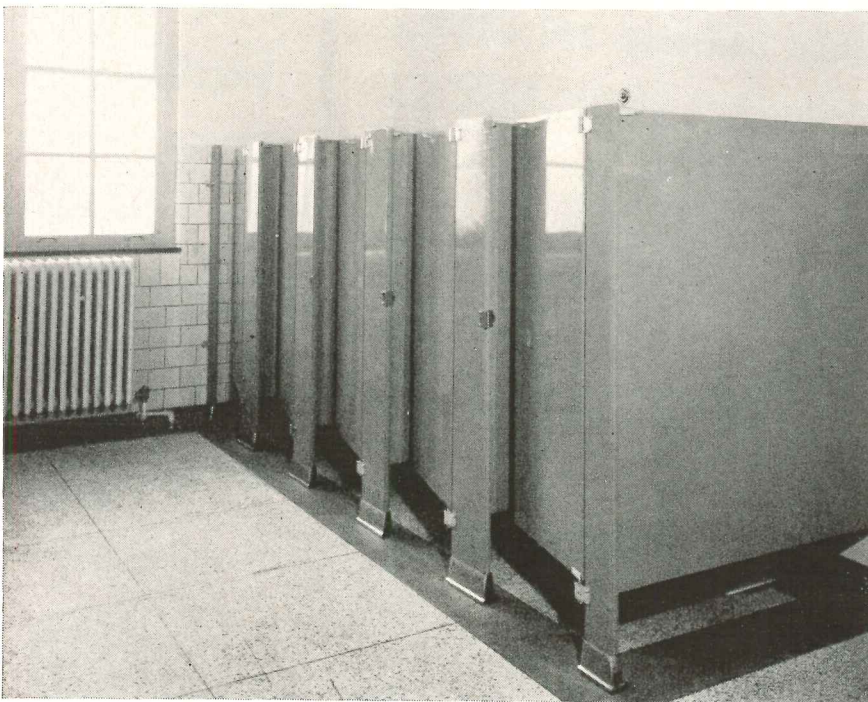

WeisArt installation in Thomas Howe High School, Indianapolis, Ind.  
McGuire and Shook, Indianapolis, architects.

WeisArt Flush Compartments provide the triple protection of galvanized, bonderized steel and modern synthetic gum enamels—materials which have proved most adaptable and desirable for toilet partitions in modern building practice. They are available in any color you wish, to match or harmonize with any color scheme.

Notice the clean-lined appearance of a WeisArt installation. Rigid flush stile construction eliminates post and head rail. Exclusive Weis gravity cut out type top hinges permit doors and stiles to line up at top. The sparkling finish not only enhances appearance—it is both durable and easy to keep spotlessly clean and sanitary. For assured satisfaction in the finest class of construction specify WeisArt Flush Compartments. Write now for information and specification details.

**HENRY WEIS MFG. CO., INC., 603 WEISWAY BLDG., ELKHART, IND.**

### NEWS FROM CANADA

*(Continued from page 156)*

"The field is not overcrowded," Mr. Mathers continues. "There are many openings for the young architect who is prepared to establish himself in smaller cities. It is fairly difficult to get established in large cities where competition with recognized architects must be met." Pointing out the danger of becoming too involved with outside activities, he concludes "Attention to business is the main thing if clients are to be satisfied."

#### Corporation Makes Annual Report

Lending operations of Central Mortgage & Housing Corporation reached an all-time high last year, according to president D. B. Mansur's annual report.

The total number of dwelling units completed in 1948 was 81,243. Loans approved by the Corporation, both direct and jointly with lending institutions, amounted to \$41.2 million. This sum covered 18,827 units, an increase of 72 per cent over 1947's total of 10,933 units.

Of the 81,243 dwelling units completed in 1948, 6,934 or 9 per cent were built under direct C.M.H.C. auspices. Another 11,939 or 15 per cent were built under the National Housing Act jointly with lending institutions. The integrated housing scheme accounted for slightly less than one-third of the National Housing Act units.

The average loan per dwelling unit rose from \$4,869 in 1947 to \$5,399 in 1948. Preference was for single family, one story houses, with single family, one-and-a-half story houses in second place.

Gross revenue during the year was \$11.5 million, realized chiefly from property rentals and interest on Housing Act loans. After allowing deductions for administration, maintenance, depreciation and other charges, a net income of \$2.5 million was left. This sum was transferred to the reserve fund, which stood at \$7.2 million at December 31. In accordance with the legislation creating Central Mortgage the fund was reduced to \$5.0 million by the transfer of \$2.2 million to the Dominion treasury.

#### Completions Up 50 Per Cent

The number of dwelling units completed during the first two months of 1949 is estimated at 11,450 by the Dominion Bureau of Statistics. In the same

*(Continued on page 160)*

# How Arc Welding Simplifies Beam-To-Column Connections

**M**ODERN welded buildings are being erected in less time and at lower cost with arc welding. Structural members are designed to permit fast shop fabrication wherever possible. For erection, columns, girders and beams are aligned, bolted, guyed and then arc welded with Lincoln "Fleetweld 5" electrodes using Lincoln Engine Driven "Shield-Arc" DC welders. The following examples of beam-to-column framing are typical of structural connections being used on multiple story buildings in various parts of the country and are discussed in detail in a new series of Structural Studies, available from The Lincoln Electric Company.

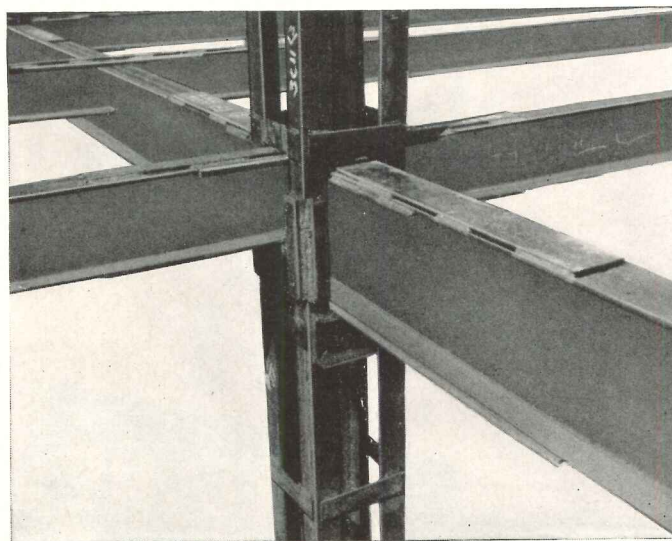

Fig. 1. Main girders, supported on cross channel plates, run directly through main columns. Four column angle sections shown are for temporary support during erection and later serve for composite steel and concrete columns. This construction is used on a Los Angeles Bell Telephone Building extension.

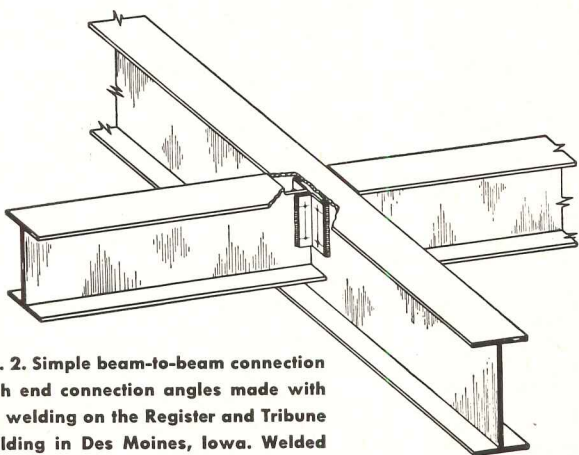

Fig. 2. Simple beam-to-beam connection with end connection angles made with arc welding on the Register and Tribune Building in Des Moines, Iowa. Welded design assures exact span length for beams and exact spacing of main girders.

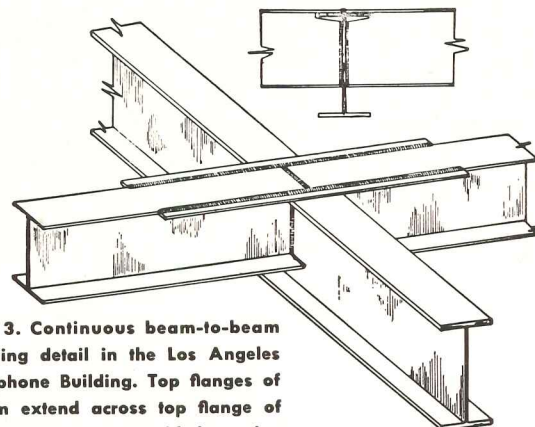

Fig. 3. Continuous beam-to-beam framing detail in the Los Angeles Telephone Building. Top flanges of beam extend across top flange of girder and are butt welded together on center line of girder.

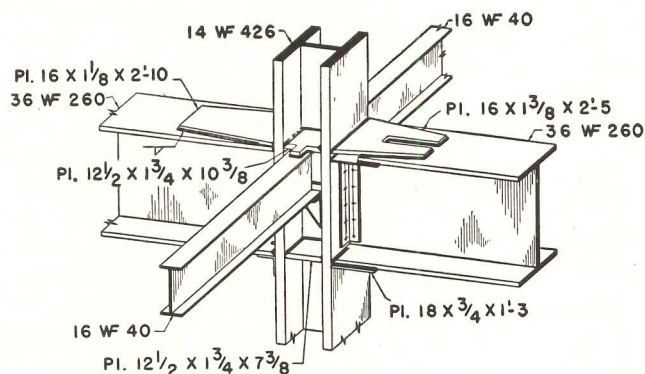

Fig. 4. Framing details at third floor level of ten story addition to Register and Tribune Building. All holes are eliminated from main columns by fillet welding or plug welding erection brackets to web and erection angles to column flanges.

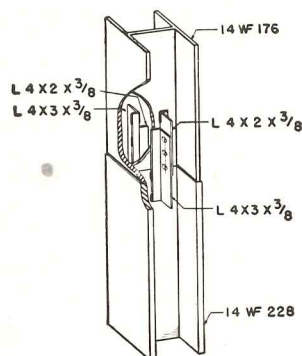

Fig. 5. Column splice at third floor level uses splice angles shop-welded to column webs. During erection, angles serve to hold columns in alignment while field-welding. Column ends are milled square in the shop and edges bevelled for simpler field-welding.

The above is published by **THE LINCOLN ELECTRIC COMPANY** in the interests of progress. More complete details on above structural welded designs are given in S.S.A.W. Plates 113, 114 and 115. Free to engineers. Write on your letterhead to The Lincoln Electric Company, Dept. 152, Cleveland 1, Ohio.

in **MODERN**  
buildings...

it's

**ALBERENE**

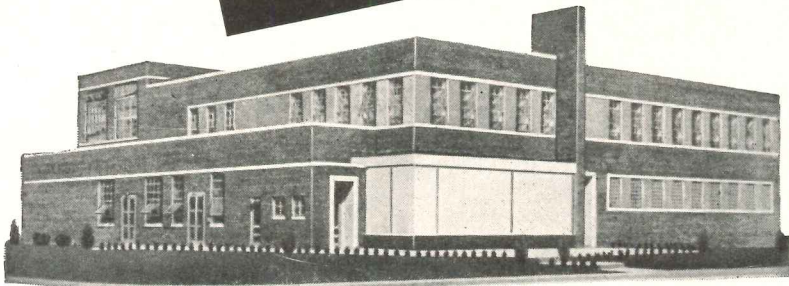

Modern dairy plant in Richmond, Virginia.  
Architects: Ballou & Justice

In this attractive, modern plant, it's *mullions* by Alberene — because Alberene mullions match so well the shadow effect of the windows . . . blend so perfectly with the exterior of the building as a whole.

And . . . it's Alberene Stone, too, for modern-looking, durable, maintenance-free spandrels . . . sills . . . stools . . . trim.

Here's why —

- **Esthetically**, Alberene soapstone is *right* for giving a building — institutional or industrial — the modern touch. *Because* . . . its natural greenish-blue color harmonizes with any decorative pattern. *And* its moisture-proof surface does not chip, scale, or split — it *always* looks good!

- **Financially**, Alberene soapstone is *right* for pleasing even your most budget-minded client. *Because* . . . its reasonable price . . . its ability to be cut into thin sections . . . *and* its outstanding durability makes it *triple* economical.

Why not write or phone us today  
for samples and further information?

**ALBERENE STONE CORPORATION**  
of VIRGINIA

419 — 4th Ave., New York 16, N. Y.

## NEWS FROM CANADA

(Continued from page 158)

period construction commenced on 4,811 units, and the number under construction dropped from 56,456 at January 1 to 49,667 at February 28. Completions in these two months are about 50 per cent higher than in the corresponding period last year.

The Bureau estimates that one-quarter of the dwelling units completed in the first two months of 1949 were for rental purposes and the remaining three-quarters were for owner-occupancy. These proportions are the same as those for rental and owner-occupancy housing built during 1948.

The average length of time required to build the dwelling units completed in February was 7.3 months. This represents the normal seasonal increase. Only 17 per cent of the dwelling units took more than 9 months to complete.

### Low Rents For Non-Vets?

The crying need is for more low-rental housing for non-veterans, Reconstruction Minister R. H. Winters declared in a recent address to the Toronto Junior Board of Trade.

"It is the hope of the government that as much new housing as possible can be provided through private endeavor and local enterprise," Mr. Winters said. "Privately initiated housing may, nevertheless, have to be supplemented by even further government support. Because of the constitutional problem, this will be dependent on the cooperation between all levels of government."

The Dominion Government, through Central Mortgage & Housing Corporation, is now directly involved in building low-rental housing for veterans. The projects are jointly subsidized by the government and the municipalities concerned. Any new proposal is likely to require provincial participation to insure its success. Municipalities complain they cannot provide the necessary schools and services for government housing projects since they don't pay the full rate of taxation. Any expansion in the low-rental field is almost certain to require that local sources of revenue be augmented by provincial grants.

### Townsite for Mining Company

Discovery of new lead, zinc and copper fields 350 miles north of St. John's, Newfoundland, leads to announcement

(Continued on page 162)





*The Navy Uses*  
**MILLS**  
 METAL PARTITIONS

A typical laboratory

**... more than four miles of them ... in the great new**  
**UNITED STATES NAVAL ORDNANCE LABORATORY**  
 Architects: Eggers & Higgins, New York      Builders: Charles H. Tompkins Co., Washington



A typical corridor

The U. S. Naval Ordnance Laboratory at White Oak, Maryland is one of the most modern and best equipped research and development establishments in the world. Comprising nearly 100 buildings on a 938 acre tract, it employs 2,300 people working in nearly every field of physical science and engineering.

Meeting the Navy's most exacting specifications, Mills standard and custom built partitions and wall linings and specially fabricated panels transform building interiors into offices, general laboratories, engineering and mechanical testing laboratories and many other enclosures. As White Oak's space needs change, these Mills partitions will be rearranged to fit the new requirements—quickly, easily, economically.

**T**HIS IS one of the world's largest installations of movable steel partitions.

But *quality* rather than size is its most significant feature . . . quality that is characteristic of Mills Metal Partitions. These movable walls incorporate exclusive features . . . such as all welded construction of individual partition units and sound-deadening treatment of their surfaces . . . features that make Mills the demonstrably superior system for flexible division of floor space.

Insulated and sound proofed to provide ideal working conditions, Mills Metal Partitions are permanent in appearance and function. Yet they can be quickly dismantled and rearranged to meet changes in space requirements. In many instances the change can be accomplished over night or during a weekend.

Simple and refined in architectural design they are available in a wide variety of styles, durable finishes and attractive colors to meet specific requirements for buildings of every type. *The Mills Company, 961 Wayside Road, Cleveland 10, Ohio.*

*Mills Metal Partitions can solve your space division problems. See the new 44 page Mills Catalog in Sweet's Architectural File for 1949 or write for your own easy-to-handle individual copy. Just ask for Mills Catalog 49-0.*



**OAKLAND, CALIFORNIA    HUNTINGTON PARK, CALIF.    FRESNO, CALIFORNIA**  
 3743 Alameda Ave.      2071 Laura Ave.      1703 Fulton St.

**REPRESENTATIVES IN ALL PRINCIPAL CITIES**

(Continued from page 160)

by the Buchans Mining Company that it will spend \$2 million on a townsite in the vicinity. It will include 100 houses, schools, stores and municipal and company buildings. The Dominion Government has also stated that extensive harbor works, road improvement and housing development will be undertaken throughout the island.

**Integrated Plan to Continue**

Doubt as to the future of Central Mortgage & Housing Corporation's integrated housing plan has been dispelled by Hon. R. H. Winters, Minister of Reconstruction and Supply. Until it was suspended on Dec. 31, the plan was widely used by builders to erect houses for sale to veterans at a price approved by Central Mortgage. The Corporation undertook to arrange priorities for materials and to buy any houses remaining unsold after a certain length of time.

In the past, some buyers of integrated houses have relied on the agreement between the builder and Central Mortgage to protect their interests. Mr. Winters says, "While there is nothing in the arrangement that justified this assumption, the Government feels that it would not be prudent to proceed with the plan without taking steps to correct this situation by reducing the possibility of its recurrence and making provision for remedial action where failure does occur in the future."

More than 13,000 houses have been undertaken using the integrated plan and all but 43 of those completed have been sold. Central Mortgage took over the latter in accordance with its purchase commitment. On the other hand, various buyers have been in danger of losing down payments made to the builder, or have had to pay higher prices because the builder ran into financial difficulty. Classic case is a Calgary project where the builder downed tools leaving 40 veterans in the lurch (ARCHITECTURAL RECORD, Jan., 1949). During the ensuing litigation, the counsel for Central Mortgage and the Manufacturers' Life Assurance Company, co-lender under the National Housing Act, assured the victims that their down payments would be refunded.

The new rules provide that no sale is to be made final until the house is 90 per

(Continued on page 164)

AND DISPLAYS

send for your copy *today!*

Special sizes in any style require 1110

MICHAELS PRODUCTS

STOREFRONTS · DOORS  
· THRESHOLDS ·  
LETTERING · ASTRAGALS  
· BRONZE PLAQUES ·

THE MICHAELS ART BRONZE CO., INC. COVINGTON, KENTUCKY

Every architect and builder should have a copy of this brochure. It contains much information on Michaels building products... products that are well known for their unusually high quality. And architects have found that Michaels has the men, the machines, and the know-how to faithfully reproduce in metal their most exacting specifications. A partial list of Michaels stainless steel, aluminum and bronze products is shown below. If your plans call for something special, send us the blueprints. We'll be glad to submit quotations. It will be to your advantage to talk over your requirements with Michaels.

**MICHAELS PRODUCTS**

- |   |   |
|---|---|
| <ul style="list-style-type: none"> <li>Bank Screens and Partitions</li> <li>Welded Bronze Doors</li> <li>Elevator Doors</li> <li>Store Fronts</li> <li>Lettering</li> <li>Check Desks (standing and wall)</li> <li>Lamp Standards</li> <li>Marqueses</li> <li>Tablets and Signs</li> <li>Name Plates</li> </ul> | <ul style="list-style-type: none"> <li>Astragals (adjustable)</li> <li>Stair Railings (cast and wrought)</li> <li>Wrought and Cast Radiator Grilles</li> <li>Grilles and Wickets</li> <li>Kick and Push Plates</li> <li>Push Bars</li> <li>Cast Thresholds</li> <li>Extruded Thresholds</li> <li>MI-CO Parking Meters</li> <li>Museum Trophy Cases</li> </ul> |
|---|---|

**The MICHAELS ART BRONZE Co., Inc., 234 Scott St., Covington, Ky.**  
Representatives Wanted





**Beauty can be  
Practical**

**Bruce Block Floors combine modern beauty with important practical advantages. Acclaimed by architects as ideal floor for homes, apartments, schools, offices, stores.**

There's no floor more stylish or more beautiful than one of hardwood in modern block design. And there's no other type of floor that also has all these practical features: (1) Easily installed over concrete or wood; (2) Lasts the life of the building; (3) Comfortable underfoot—warm, resilient, quiet; (4) Economical to maintain in perfect condition.

Over 100 million feet of Bruce Blocks are now giving completely satisfactory floor service in homes and buildings throughout the nation.

*See our catalog in Sweet's or write E. L. Bruce Co., Memphis, Tenn.*



## **Bruce Block**

### **HARDWOOD FLOORS**

*Product of World's Largest Maker  
of Hardwood Floors*

**Other Bruce Products:** Strip and Plank Hardwood Floors • Yellow Pine and Hardwood Lumber • Bruce Floor Cleaner, Waxes, Finishes • The Bruce Doozit

# Seaporcel does it better -

*... and is better prepared than  
ever to serve its customers ...*  
**IN THE PORCELAIN ENAMEL ARCHITECTURAL FIELDS**

- ① Because of the knowledge and skill acquired through 20 years of specialization in this field by trained, intelligent personnel.
- ② Unexcelled sheet metal and porcelain enameling facilities in a continuously expanding organization.
- ③ Architects' and designers' specifications rigidly adhered to.
- ④ Architectural porcelain enamel produced in any shape, quantity, texture, size, color or shade (only excepting the metallics).
- ⑤ Many stock dies for many shaped pieces.
- ⑥ National sales and service agents with capable erection crews in many sections of the country.
- ⑦ Competitive Prices • Superior Quality • Rapid Deliveries.
- ⑧ A management that is mindful of the help and cooperation of the customers we have served for so many years and whose consideration we hope to merit for many, many more years.

*Write today for catalogue showing application and current jobs or send for a 12" x 12" sample of a shaped part in terra cotta finish.*

## **SEAPORCEL METALS, INC.**

Formerly Porcelain Metals, Inc.  
28-02 Borden Ave., Long Island City 1, N. Y.  
Complete A. F. of L.-Metal Fabricating  
& Enameling Shop

Also manufactured on the West Coast  
**SEAPORCEL CORPORATION OF CALIFORNIA**  
Represented by McFarland Co., 1206 West 7th St., Long Beach, Calif.



\*Reg. U.S. Pat. Off.

# Seaporcel

Member Porcelain Enamel Institute, Inc.

*The background illustration is a Seaporcel Architectural Shaped Part.*

## NEWS FROM CANADA

(Continued from page 162)

cent completed. Down payments made by the purchaser are to be placed in trust until delivery of the house, and the builder must produce paid bills when applying for mortgage advances.

When the house has reached the first floor joists stage of construction, the builder must deliver a conveyance of the property to Central Mortgage, in order to give the Corporation effective control until the work is finished. At the same time as it receives the conveyance, the Corporation provides working capital for the builder by advancing him the difference between the mortgage loan and the sale price.

### Claims Toronto Children Doped

Attention has been drawn to an appalling by-product of the housing situation in Toronto — and no doubt other large cities as well — by Hugo Wolter, consultant to the Civic Advisory Council. He says that the children of many tenant families are being kept in a constant state of repression. Inadequate, congested housing restricts their play and a chance to release surplus energy. They become irritable, unable to sleep and sedatives are given to keep them quiet. A cycle of dosing develops.

Dr. Alan Brown, chief of the medical staff of Toronto's Hospital for Sick Children and leading child authority, agrees that sedatives are being widely prescribed for children. In a newspaper interview he declared that the crowded conditions under which many families must live will be reflected in the psychological outlook and physical health of the children in the next few years. "Most child problems today," he said, "can be traced to poor housing conditions."

In an anticipated federal election year, Mr. Wolter's claim and Dr. Brown's confirmation of it may be expected to add fuel to the flames of agitation for a national public housing program.

### Research Station Set Up

The first regional station of the Division of Building Research, National Research Council, has been established at the Council's prairie regional laboratory on the campus of the University of Saskatchewan. The Division thus enters into active collaboration with a University well known for its outstanding work on deterioration of concrete in alkali

(Continued on page 168)



*Lovely to live with...*



## More Elegant... and more Practical... than floors of comparable cost

On the present-day emphasis on natural beauty in materials, Kencork's pure cork tiles take on added importance in the designing of fine homes. Clients with a flair for elegance readily take to the subtle Kencork tones... realize how graciously Kencork's natural beauty lends itself to any decorative treatments.

On the practical side, Kencork comes well recommended, too. Its service records of 25 years and more are not surprising when you know each Kencork Tile gives you 6 inches of tough elastic cork compressed under pressure to fractions of an inch. Resilient, it yields to footsteps, is outstanding for comfort and quiet. Throughout its lifetime, it is easy and inexpensive to maintain.

Yet... Kencork compares in price with floors that cannot equal it in elegance and practical advantages. Investigate Kencork—for homes, smart shops, public buildings.

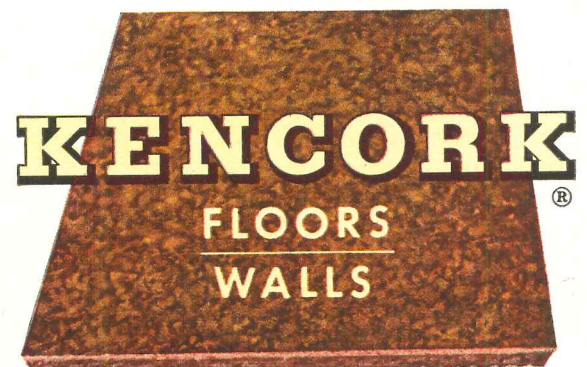

On floors or walls, Kencork's rich browns and golden tans offer a perfect background for modern or period designs.

# SUPER-CLEAN AIR for Super-Safe Flying

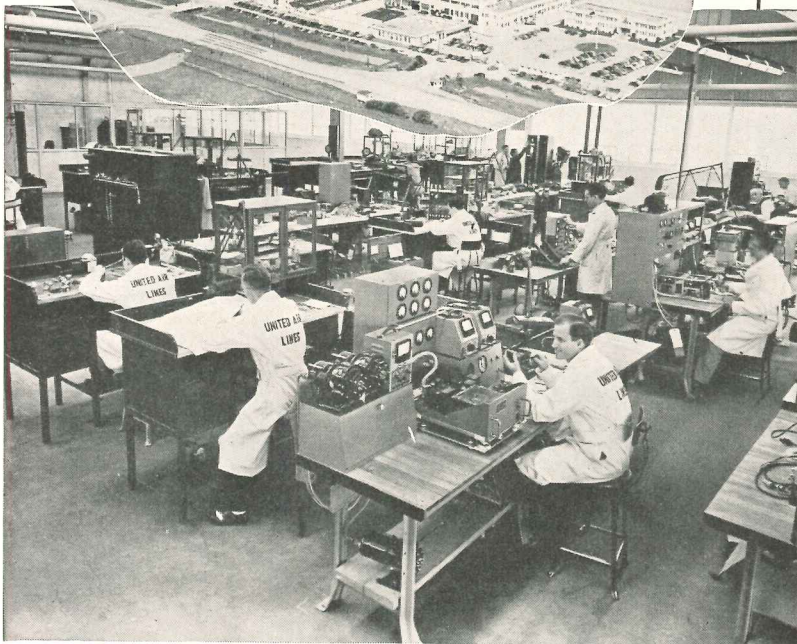
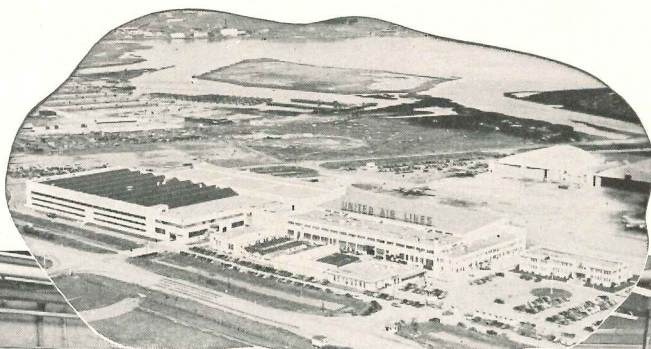

Instrument shop at United Air Lines Maintenance Base supplied with filtered air by AAF Electro-Airmat Electronic Precipitators.

THE AUSTIN COMPANY, *Engineers and Builders*

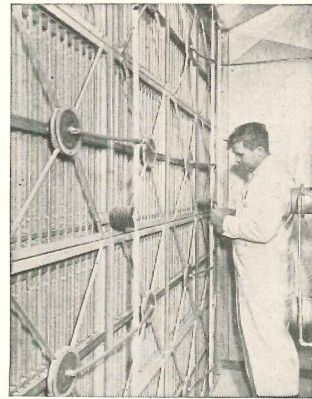

## Dust and dirt are "grounded" for keeps by AAF Electronic Precipitators at United Maintenance Base

**T**HIS new United Air Lines Maintenance Base at San Francisco is dedicated to keeping them "flying right". Nothing has been overlooked that will contribute to precision workmanship—even to providing work areas with air free from dust and dirt.

The instrument shop, pictured at left, as well as the engine overhaul department are supplied with air filtered by AAF Electro-Airmat\* Electronic Precipitators. Here, where even the smallest foreign particle might counteract the efforts of the finest technician, work can be carried on free from the dangers of dust or soot.

Many manufacturers and store owners have found it profitable to become "air conscious". Airborne dust, dirt and soot enact heavy penalties yearly in rejects, mark downs and maintenance costs—all of which can be eliminated by the proper application of AAF air filters.

Your customers' air cleaning problems are in safe hands when you bring them to American Air Filter. AAF recommendations are unbiased because it is the only company manufacturing a complete line of air filters—sound because they're based on over 25 years of engineering success in this specialized field. For complete product and application data, call your nearby AAF representative or write direct to:

**AMERICAN AIR FILTER COMPANY, INC.**  
389 Central Avenue, Louisville 8, Ky.  
*In Canada: Darling Bros., Ltd., Montreal, P. Q.*

**AAF**

**AIR FILTERS  
AND ELECTRONIC PRECIPITATORS**

\*Airmat is the trade-mark (Reg. U. S. Pat. Off.) of the American Air Filter Company, Inc., for various air filters, dust collectors, and filtering media.

**THERE'S A REASON WHY**

when **DRAINS** are called for  
**THE MAJORITY** calls for **Josam**

★ Josam's leadership in the field of plumbing drainage didn't just happen. The reason for it is that Josam has never been content to follow, but has been continuously pioneering and developing new plumbing drainage products. For example, the three products illustrated on this page, are a few of many invented by Josam which are the standard of the industry today. Because of the extent of the Josam line, chances are that there is a product in the Josam line designed to meet the need exactly...even though it looks "special". For example, there are over 870 types of Josam floor and roof drains alone manufactured today. Why take chances on drainage problems, when Josam takes out the guesswork for you. Do as the majority does—get the details first on Josam products. Use convenient coupon below for quick action!

**Josam Non-Clog Triple Drainage Floor Drains**

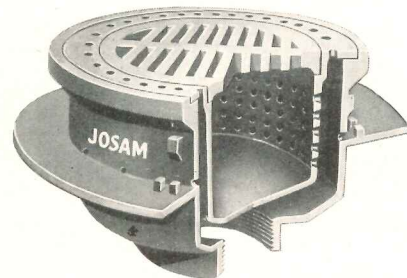

Developed by Josam to prevent drain lines from becoming clogged with debris and to assure continuous drainage of water. If sediment container becomes filled, drainage continues through holes in auxiliary rim, signalling need for cleaning.

**Josam Adjustable Top **LEVELEZE** Floor Drains**

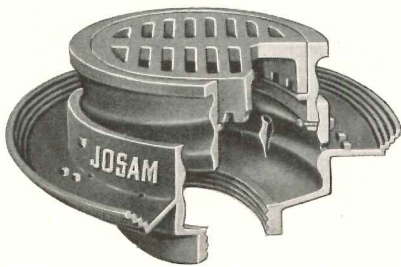

An exclusive Josam development to solve drainage problems caused by variations in floor levels. Now, for any reason, where the floor level is changed after the drain is installed, simply raise or lower the adjustable top—and the new floor is met!

**Josam Roof Drains with Removable Dome Strainer and Sediment Cup**

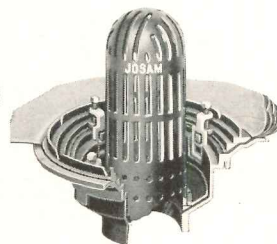

Pioneered by Josam to permit continuous drainage in spite of accumulation of debris on roofs. Today it is the widest used roof drain in the industry because it is adapted to the greatest number of roof conditions. Also available with promenade top, or with extra large dome or with integral expansion joint.

**OTHER JOSAM DEVELOPMENTS OVER THE YEARS**



GREASE INTERCEPTORS



SWIMMING POOL EQUIPMENT



SHOCK ABSORBERS



BACKWATER SEWER VALVES

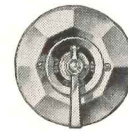

MODERATOR SHOWER MIXING VALVES



OIL INTERCEPTORS

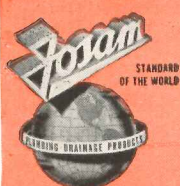

**JOSAM MANUFACTURING COMPANY**

Main Sales Offices, Josam Building, Cleveland 13, Ohio  
 Manufacturing Division—Michigan City, Indiana  
 Representatives In All Principal Cities

**JOSAM-PACIFIC CO.**, San Francisco, Cal., West Coast Dstbrs.  
**EMPIRE BRASS CO., LTD.**, London, Ont., Canadian Dstbrs.

See our Catalog in Sweets'

Member of the Producer's Council

**FILL OUT AND MAIL THIS COUPON—TODAY!**

Josam Mfg. Co., 302 Josam Bldg., Cleveland 13, Ohio  
 Please send free literature on the following types of drains:

NAME \_\_\_\_\_  
 FIRM \_\_\_\_\_  
 ADDRESS \_\_\_\_\_  
 CITY and STATE \_\_\_\_\_

FOR ENDURING WHITENESS

...STUCCO

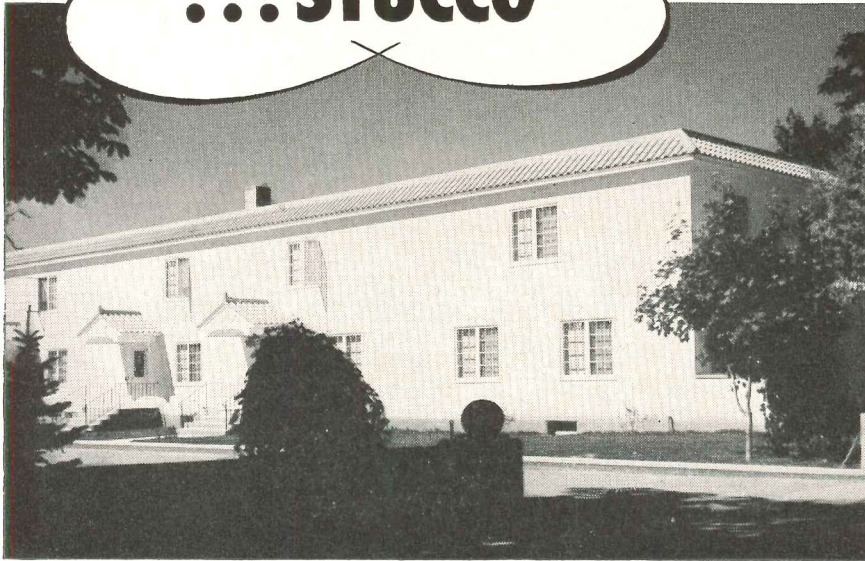

## For lasting stucco... ATLAS WHITE CEMENT

Here's whiteness, appealing brightness that finds and fills the eye... lasting beauty that smiles at time and weather. It is clean, crisp, enduring stucco... made with a matrix of Atlas White Cement.

Such a matrix... pure white, or one of an infinite variety of pigment-based colors... brings out the full beauty of stucco. It also sets off, in blend or contrast, the full color of pigments used in portland cement paint or the aggregates used in terrazzo and architectural concrete slabs.

Utility? Durability? Atlas White Cement complies with ASTM and Federal Specifications for portland cement. It has the same advantages when used for concrete. Stucco, cement-paint, terrazzo, architectural slabs... made with Atlas White Cement... all clean easily and maintenance costs stay low.

### ATLAS WHITE \*DURAPLASTIC

air-entraining portland cement adds new advantages to stucco at no extra cost. It provides increased plasticity that makes application easier; insures greater durability; offers stouter resistance to weather. Ask for details.

For further information on the uses of Atlas White Cement, see SWEET'S Catalog, Section 4B/3 and 13C/5, or write to Atlas White Bureau, Universal Atlas Cement Co. (United States Steel Corp. Subsidiary), Chrysler Bldg., New York 17, N. Y.

*\*DURAPLASTIC is the registered trade mark of the air-entraining portland cement made by the Universal Atlas Cement Company.*

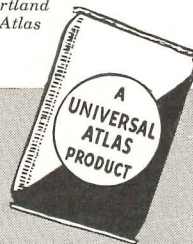

FOR BEAUTY AND UTILITY

# ATLAS WHITE CEMENT

FOR TERRAZZO, PAINT, SLABS, STUCCO

"THEATRE GUILD ON THE AIR"—Sponsored by U. S. Steel Subsidiaries  
Sunday Evenings—ABC Network

## NEWS FROM CANADA

(Continued from page 164)

soils, rammed earth, cinder concrete, insulation, building papers and other construction problems.

The station consists of a room 44 by 22 ft., fitted with apparatus for full-scale testing of wall panels, 8 by 7 ft., under conditions of simultaneous heat and water vapor flow. Refrigeration equipment will provide air temperatures down to  $-40^{\circ}$  F on one side of the panel, while temperature and humidity on the other side are controlled at levels normally encountered inside buildings. It is intended that this cooperative research project will serve as a model for similar enterprises to be initiated by the Division of Building Research with other Universities.

### Construction Pace Quickens

According to MacLean Building Reports, construction contracts awarded for the first three months of 1949 totaled \$203.7 million compared to \$128.5 million for the same period in 1948. This is an increase of nearly 60 per cent. It goes a long way to insure confidence in a recent Department of Trade & Commerce forecast of a 12 per cent dollar gain in new construction investment this year.

March totals were \$67.6 million and \$51.3 million for 1949 and 1948, respectively, showing a boost of over 30 per cent. Revived interest in industrial building and, to a lesser extent, engineering construction, was responsible. Residential and commercial building registered slight set-backs, for the first time in months. Residential remained the largest category for the quarter with awards totaling \$69.4 million.

The staying power of the postwar housing boom has astonished many economists. Since 1946 there's been no shortage of expert opinion that the backlog of shelter demand would shortly be reduced and the force behind high prices peter out. This conclusion cannot be justified in view of the large amount of new housing business being placed. It may be true enough in the long run, but the financial soothsayers appear to have been premature in the timing of their prophecies.

### Easier Credit Seen Inadvisable

The National House Builders' Association continues to agitate for higher loan appraisals under the National

(Continued on page 170)

AR-C-27



TAKE A LOOK AT THIS ESTIMATE! I NEVER KNEW  
FABRON WALL COVERING WAS SO REASONABLE!

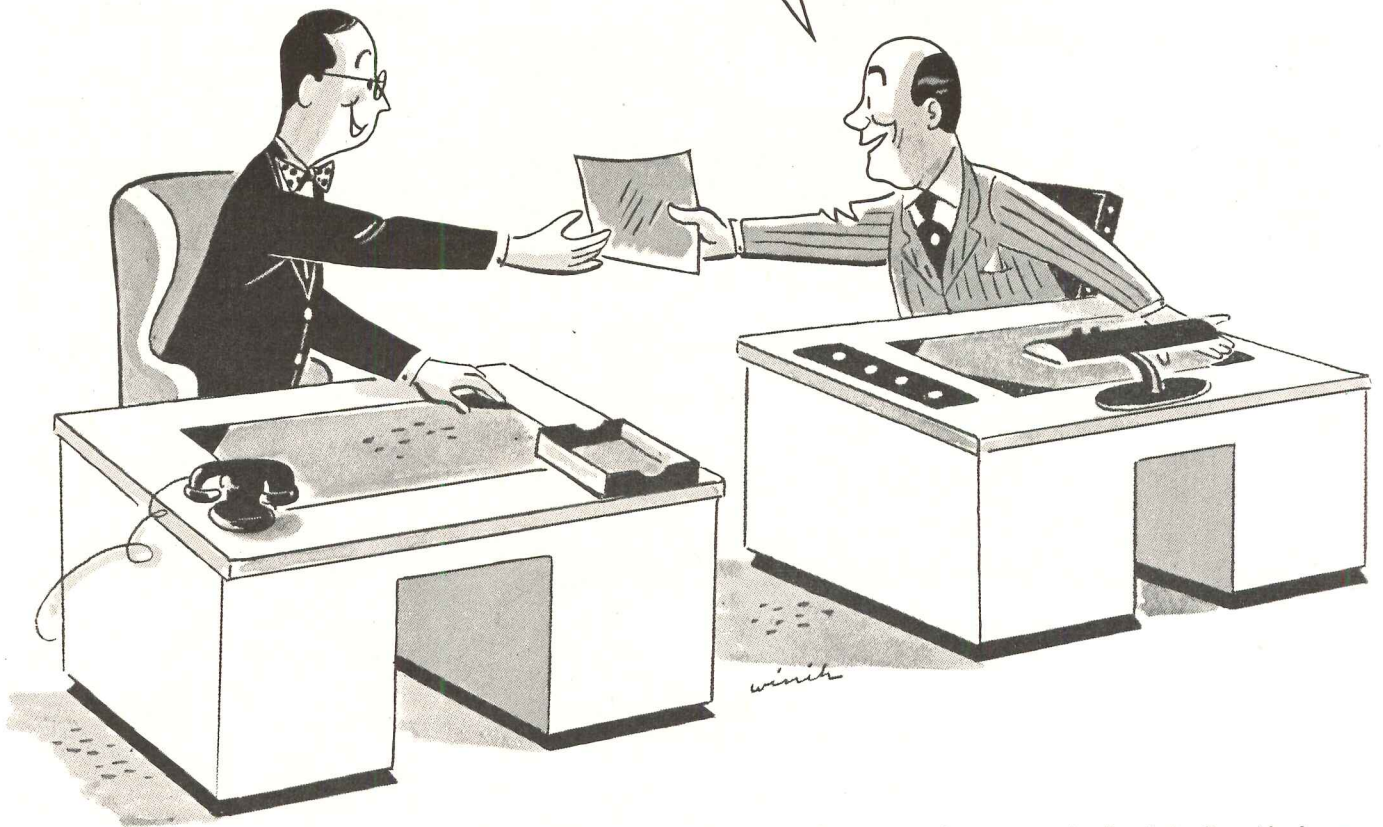

• Some architects naturally assume that FABRON is too expensive for their clients' budgets. What a pleasant surprise when they learn its true cost! For this canvas-plastic-lacquer covering is so beautiful, so practical and of such high quality that they can hardly believe it comes within the average decorating budget. Yet it does. And, in addition, it pays for itself several times over because it reduces maintenance to the minimum . . . eliminates periodic redecorating . . . outlasts paint by several redecorating periods.

If you have taken FABRON's cost for granted, find out its *true* cost on your next institutional project. From your blueprints we'll gladly furnish material estimates and approximate installation costs. Moreover, we'll be pleased to draw up a suggested decorative scheme—complete with samples—if you feel it will be helpful. No obligation, of course.

**IMPORTANT:** FABRON, being a specialty, requires somewhat different handling in specification if it is to be obtained at the lowest cost, avoiding penalties and extras. Let us help you with data on FABRON *before your next project reaches the specification stage!*

FREDERIC BLANK & CO., INC. • Est. 1913 • 230 PARK AVE., NEW YORK 17, N.Y.  
Represented in Canada by The Robert Simpson Company Limited—Special Contract Division

• In one operation, FABRON hides plaster blemishes, prevents expensive plaster repairs, assures complete washability and color fastness. Saves money to the owner by eliminating periodic redecorations. Initial cost falls within present-day budget. Furnished in double rolls. Applied like wallpaper. Easily repaired by invisible inlay method. More than 180 colors, textures and patterns offer a decorative latitude unmatched by conventional treatments. And—FABRON prevents the spread of fire, carries the label of the Underwriters' Laboratories, Inc.

tested  
Underwriters' Laboratories, Inc.  
NATIONAL BOARD OF FIRE UNDERWRITERS



THE ROOSEVELT HOTEL  
New Orleans, La.

Seymour Weiss, Pres. & Mng. Dir.

One of the many hotels where FABRON is used for its good appearance, long term durability and easy maintenance. FABRON is serving in countless institutional buildings such as hotels, hospitals, universities, commercial buildings, theatres, etc.

Fabron®



The canvas-plastic-lacquer wall covering for institutions

(Continued from page 168)

Shower Cabinets designed for...

Modern bathrooms

by...

FIAT

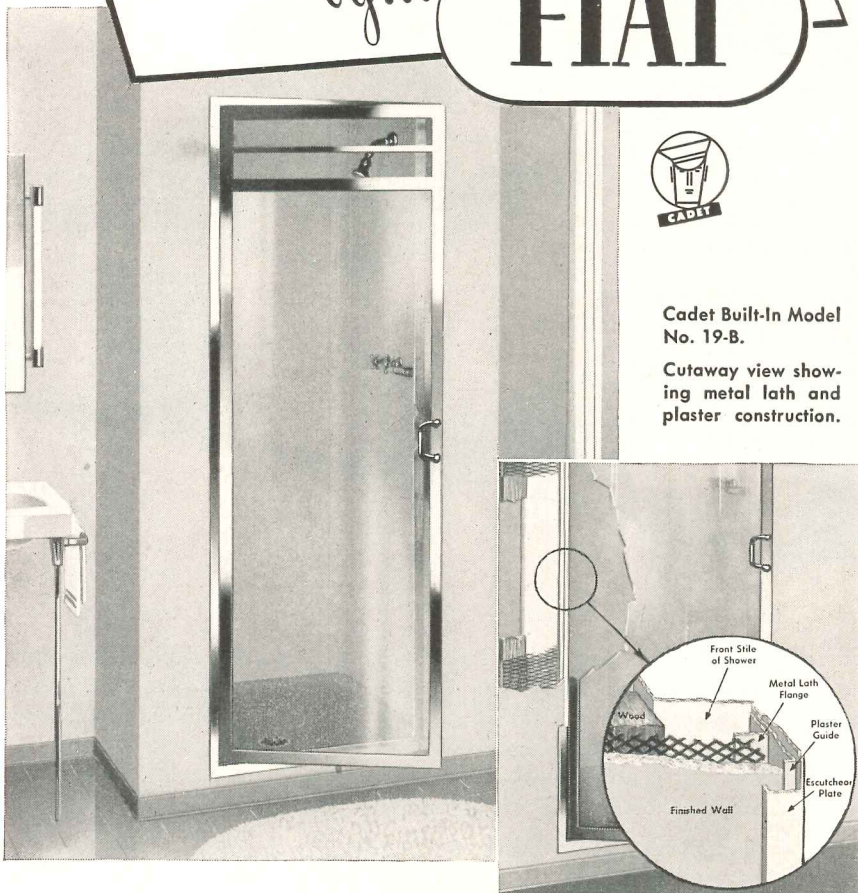

Cadet Built-In Model  
No. 19-B.

Cutaway view showing  
metal lath and  
plaster construction.

### Big Cities Vulnerable Targets

Should lending for industrial expansion and housing construction be brought to an end in Toronto and Montreal? Lt. Col. Douglas S. Harkness, M.P. for Calgary East, thinks so.

In a recent speech in the House of Commons, Colonel Harkness urged the government to take steps to minimize loss of life in the event of an atomic war. To encourage dispersal of industry, he suggested that the Industrial Development Bank refuse loans to firms wishing to build in congested urban areas and extend loans freely to firms wishing to establish elsewhere. Pressure, he said, could be put on other lending institutions to achieve the same end.

Without being alarmists, many residents in Canada's two metropolises have been concerned with the way in which new buildings of vital importance are being crowded together. Toronto, for instance, is putting all its hospital eggs in one basket. When its current building program is completed, over three-fourths of the city's hospital beds will be located within a block's radius of the provincial parliament buildings and headquarters of the hydro-electric power commission, to say nothing of a university where essential scientific work is being done. Montreal, on the other hand, is jamming a new long distance exchange for overseas calls and an international aviation building into space within a stone's throw of the city's two principal railway stations.

The new Fiat shower cabinet models are especially designed for modern bathrooms and for modernizing old bathrooms.

The Built-In Cadet design No. 19-B, for example, has construction features that enable the builder to completely recess the cabinet and to extend the plaster and tile right up to the door frame which has special flanges to receive metal lath and plaster coats.

The plaster joint around the door opening is covered completely by the Fiat escutcheon that frames the door and gives a smart trim finish to the installation.

This recessed Cadet shower cabinet is simple to install and is the only shower cabinet available today that has these special built-in construction features.

Other Fiat shower cabinets now available with prompt delivery are the Commodore 2000-C, Admiral, Ensign, Cadet Corner Type, Cadet 17-R, Skipper and Plebe. See description with specifications of these showers in Sweet's Architectural File, section 246/1 and Building File, section 6a/6 or write for catalog.

FIAT

METAL MANUFACTURING COMPANY

In Canada — Fiat showers  
are made by The Porcelain  
and Metal Products, Ltd.,  
Orillia, Ontario

Chicago 13, Ill. • Long Island City 1, N. Y. • Los Angeles 33, Calif.

# Aluminum



LIFETIME PROTECTION  
FOR A STATELY OFFICE  
BUILDING...OR

*a house  
of  
charm*

Oldest aluminum roof in the world is said to be on the Chief Secretary's Office Building in Sydney, Australia—put there in 1880, and still in sound condition. Here is ample evidence of aluminum's rustproof permanence and freedom from maintenance. Add aluminum's lightness-with-strength, its heat reflectivity, corrosion resistance and soft, natural beauty, and you know why aluminum is so favored and versatile a building material.

See, for instance, how aluminum is used on the House O'Charm, in Detroit. Reynolds *Lifetime* Aluminum Gutters and Downspouts, in the new stipple-embossed finish, mate perfectly with traditional materials; with no need for protective painting, no danger of staining walls. Yet cost is only half as much as for other rustproof materials.

From the moment of Reynolds entry into aluminum production, aluminum output has steadily increased... and with it architectural appreciation of its manifold utility. Aluminum roofing and siding in various forms, aluminum windows, and architectural shapes are among the Reynolds Building Products that offer inspiration to creative minds. For descriptive literature in A.I.A. File form, please write us.

**Reynolds Metals Company**, Building Products Division,  
2014 So. Ninth St., Louisville 1, Ky.  
Offices in 32 principal cities.

**REYNOLDS *Lifetime* ALUMINUM**

IF YOU SEE RUST  
YOU KNOW IT'S NOT  
ALUMINUM



REYNOLDS  
*Lifetime* ALUMINUM  
BUILDING PRODUCTS

House O'Charm, Detroit, Michigan.  
Walter T. Anicka, Architect.  
Bain & Anderson, Builders.  
Specification for rain carrying  
equipment: Reynolds *Lifetime*  
Aluminum Stipple-Embossed  
Gutters and Downspouts, O. G. Style.

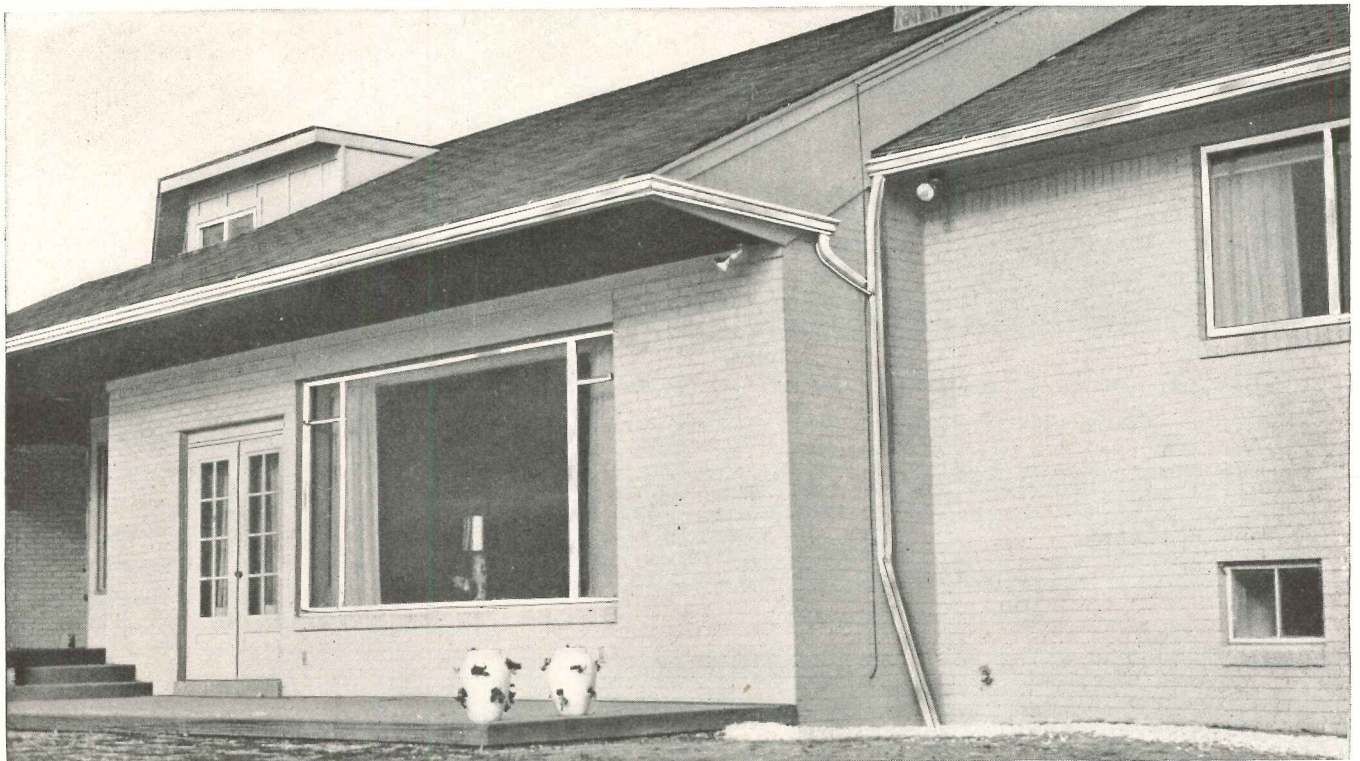

Attorney General Clark: "The vigorous enforcement of the anti trust laws with respect to all matters pertaining to housing will be continued. We are determined that the consumer shall have the benefit of the competitive prices and freedom of selection to which he is entitled."

• Late Bureau of Census figures show a marked growth in the wood prefabrication industry. Preliminary reports

from the 1947 Census of Manufacturers have shown that producers in the Prefabricated Wood Products Industry shipped products valued at \$107 million during 1947, nearly 12 times the \$9 million worth shipped in 1938 when the last such census was taken. Prefabricated homes constituted \$63 million of the 1947 total while \$8.5 million worth of dwellings was produced in 1939.

• A strong effort is being made in Con-

gress to double the financial assistance to states for construction of hospitals and health centers. New national health measures call for increasing the \$75 million per year now extended in federal aid to \$150 million annually. These funds share estimated construction costs of approved non-federal hospitals and health centers up to two-thirds of the total amount.

• Data just released by the Department of Commerce shows 46,000 builders in the country. This is an increase of 13,000 or 33 per cent over the 33,000 reported in the 1939 Census. Figures came from social security returns.

**FRANCKE HUNTINGTON BOSWORTH**

Francke Huntington Bosworth, Architect, and former dean of the College of Architecture at Cornell University, died on April 27 in New York City, following a long illness. He was 73.

Mr. Bosworth, with the late Frank Holden, founded the New York architectural firm of Bosworth & Holden in 1902 and practiced architecture there until the dissolution of the firm in 1918.

In 1920 Mr. Bosworth went to Cornell as professor of architecture and dean of the College of Architecture. He continued as dean until 1928 and as professor until his retirement in 1940.

**EDWARD P. SIMON**

Edward P. Simon, alumnus of Drexel Institute of Technology and former director of the Federal Housing Administration for the Eastern District of Pennsylvania, died at his summer home in Brant Beach, N. J., on May 10 at the age of 70.

An architect by profession, Mr. Simon was senior partner in the Philadelphia firm of Simon & Boulware and designed some of Philadelphia's best-known buildings, among them the Philadelphia Municipal Stadium, the Fidelity-Philadelphia Trust Building and the Curtis Hall of Engineering. He was also the designer of the Meade Memorial in Washington and the First National Bank and Trust Company of Camden, N. J.

**LE BRUN RECIPIENT**

The 1949 Le Brun Traveling Scholarship of \$2800 has been awarded to Miss S. Agatha Turner of Lubbock, Texas, it was recently announced by the New York Chapter, AIA. This is the first time that the well-known award has been made to a woman.

(Continued on page 174)

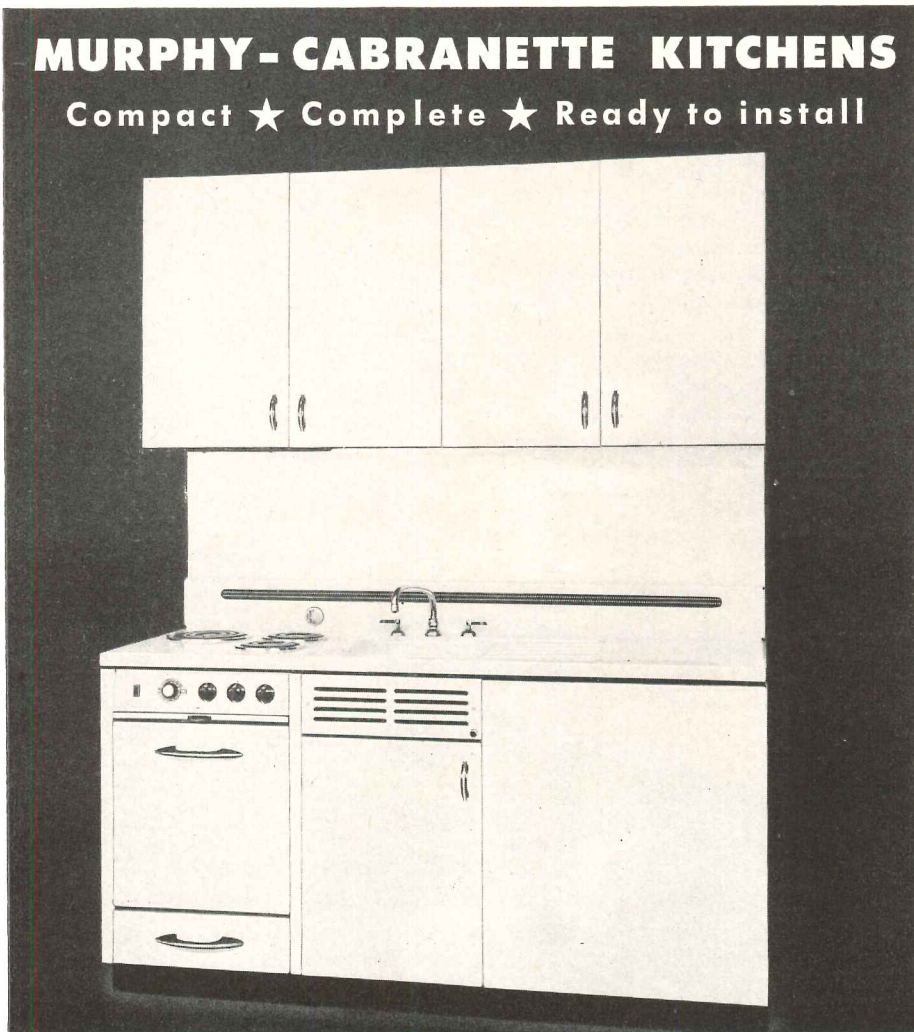

**Durability proven in 25 years of service in rental properties**

You'll find tenant appeal in the enduring beauty of genuine vitreous porcelain, in the one-piece sink and range top free from dirt-harboring cracks and crevices, in the efficient refrigerator with its smart push-button door and stainless steel frozen food compartment. You'll find durability in the vitreous porcelain surfaces that never require repainting but wash

bright and clean with soap and water. You'll find economy in a refrigerating unit of high efficiency, in a refrigerator with super-insulation, in a gas or electric range of advanced design. These are not mere claims. They are facts... proven by thousands of Murphy-Cabranette Kitchens, some of which have been in active service for over twenty years.

Write for new bulletins.

**DWYER PRODUCTS CORPORATION**  
Dept. R6 - MICHIGAN CITY, INDIANA

Fifteen such circular Marlou fixtures hang from the Rolladium ceiling. Each has a red, blue and green light with which seven different color effects can be obtained.

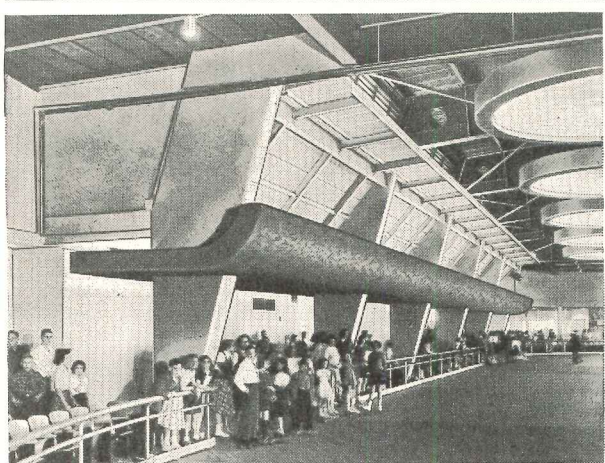
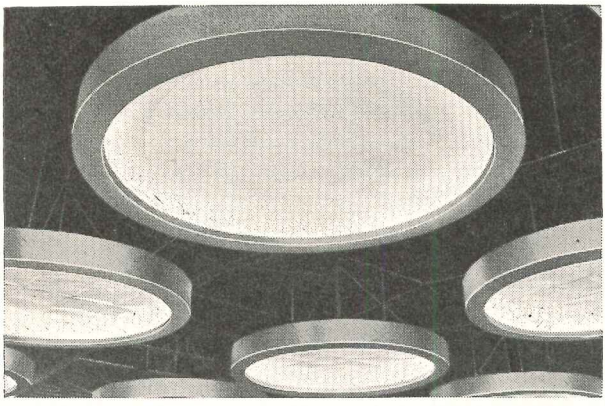

Trough light arrangement achieves soft, mellow indirect lighting in keeping with the ultra-modern decor of the Rolladium.

*Sold Through Electrical Wholesalers*

**MARLOU LIGHTS**

Cold Cathode • Slimline • Planned Lighting

50 South Avenue, Fanwood, New Jersey

**THEY ROLL BY NIGHT...**

**UNDER GLORIOUS  
MARLOU LIGHTS**

. . . in one of the world's most luxurious roller skating rinks (to quote publication, "The American Roller Skater")—the Staten Island Rolladium, New Dorp, Staten Island.

Here may be seen striking examples of Marlou's creative custom lighting, planned with architects—truly *Selective Slim Lighting*—functional, distinctive and incredibly dramatic.

For *your* next lighting project, consult Marlou first!

**Write, too, for illustrated data-packed catalog of Marlou's creative standard commercial and industrial fixtures.**

*Designers and Manufacturers of Distinctive Lighting for Industry*

**STORE REMODELING SHOW**

New York's annual Store Modernization Show will be held in Grand Central Palace June 19 to 24, under the directorship of John W. H. Evans, as heretofore. With the advent of lower prices, a buyers' market and keener competition, store modernization becomes even more of a must as an investment in merchandising than ever before. The ideas, the designs and the techniques of store mod-

ernization will be displayed, as well as all of the materials, accessories and gadgets that contribute to successful merchandising. Winning designs from the current competition for "The best modernized store of the year" will be on exhibition. This competition has been open to Chambers of Commerce and civic groups and prizes totaling \$500 have been offered.

Every day there will be interesting

forum clinics taking up the different problems of store modernization, each presided over and lectured to by experts on the particular phases in question. The question period preceding the set speeches is always a lively debate.

Arrangements have been made for the distribution of invitation tickets through the architectural magazines and other sources which will save the visitor \$1.00 of the combined registration fee and tax which, without the complimentary ticket, would cost \$1.50.

**Design Project at Washington**

Members of the upper three classes at the University of Washington School of Architecture are hard at work currently on the layout of a theoretical super-shopping center for Mercer Island. More than 150 students are engaged in the project, divided into eight working groups. Each group selected what it considered the most appropriate site on the north end of the island, and is now planning and laying out the 36 required business establishments and the parking areas needed for the center. Each group will make a scale model of the project.

**Welding Scholarship Awarded**

James Edgar Steed of Washington Court House, Ohio, a pre-junior in the department of architecture in the University of Cincinnati College of Applied Arts has been awarded the first of four \$250 annual scholarships established at the University by the Lincoln Arc Welding Foundation.

**ON THE CALENDAR**

*Through June 19:* "From Colony to Nation — The Growth of American Culture from 1650 to 1815." Exhibition of painting, silver and architecture, The Art Institute of Chicago, Chicago, Ill.

*June 3-30:* Annual Akron Art Institute School Exhibition, Akron Art Institute, Akron, Ohio.

*June 9-24:* 9th Antique Dealers' Fair, Grosvenor House, London, Eng.

*June 14-17:* 3rd I-B-R Short Course on Steam and Hot Water Heating Systems, Champaign-Urbana Campus, University of Illinois.

*June 1-Sept. 30:* "Details of the City — Photographs by Godfrey Frankel," Museum of the City of New York, New York City.

*June 19-24:* 3rd Annual Store Modernization Show, Grand Central Palace, New York City.

*June 20-23:* 42nd Annual Meeting, National Association of Building Owners  
(Continued on page 176)



• For floors that will look better and clean easier... that will last longer under the hazards to which they are subjected by everyday family life... AZPHLEX Asphalt Tile is unsurpassed. Consider these AZPHLEX plus values:

- MAXIMUM RESISTANCE** to indentation by foot traffic, rolling or standing loads.
- GREASE RESISTANT** in the highest sense of the word — won't stain or soften if subjected to animal, mineral or vegetable greases, alkalis, alcohol or mild acid solutions.
- THROUGH-AND-THROUGH COLORS** and marbling that will never wear off — fine texture that keeps a smooth, easily polished surface.
- UNIFORM HIGH QUALITY** and dimensional stability — every tile die-cut.
- CUSTOM INSTALLATION** to produce exactly the design you specify, in the colors you specify from our wide range of samples.

AZPHLEX is ideal for installation over wood, metal or concrete slab sub-floors, above, on or below grade. It is *flexible* — and so *tough* that 1/8" AZPHLEX is the equivalent of 3/16" regular asphalt tile. Available in 10 clear, true colors: 1/8" and 3/16" thicknesses: 6" x 6", 9" x 9", 6" x 12", 12" x 12", 14" x 28", 12" x 12" DUOTONE and 1" x 24" feature strips in all colors.

For complete information about AZPHLEX, call your AZROCK-AZPHLEX dealer — or write direct to

**UVALDE ROCK ASPHALT CO.**  
Makers of AZROCK and AZPHLEX Asphalt Tile  
FROST BANK BLDG. SAN ANTONIO, TEXAS



# Are you aware that **AVA CABLES** can save up to 40% on conduit size?\*

Yes, on many electrical construction or modernization jobs in dry locations,† where sizable loads are involved, you may be able to work substantial savings with G-E Deltabeston® AVA cable.

Built for locations where operating temperatures are high, Deltabeston cables are insulated with heat-beating asbestos. That's why these cables can go to work at normal temperatures in smaller sizes than ordinary Type R building cables. General Electric Deltabeston AVA cables can actually cut cable size requirements as much as 40%, because their insulation permits smaller raceways.

To you, Deltabeston AVA cables mean *installation speed*, because they can help on many jobs by reducing the number of cables you put in—*material savings*, because AVA cables permit smaller conduit sizes—*weight savings*, because small size means light weight.

It will pay you to talk over the use of General Electric Deltabeston AVA cables with your electrical contractor. For specific information, write to Section Y33-65, Construction Materials Department, General Electric Company, Bridgeport 2, Connecticut.

† As defined by the National Electrical Code.

\* The figure above was worked out for a load of 470 amperes. Similar savings can be realized for other loads.



GENERAL  ELECTRIC

ers and Managers, Mount Royal Hotel, Montreal, Canada.

June 20-24: Summer General Meeting, American Institute of Electrical Engineers, New Ocean House, Swampscott, Mass.

July 13-15: Summer Convention, American Society of Civil Engineers, Mexico City.

Aug. 23-26: Pacific General Meeting, American Institute of Electrical Engi-

neers, Fairmont Hotel, San Francisco, Cal.

**OFFICE NOTES**  
**New Addresses**

The following new addresses have been announced:

Forge Construction Co., Inc., and Powell Construction Co., Inc., General Contractors, 405 North Ave., New Rochelle, N. Y.

Edith Hernandez and Company, Interiors, 136 E. 74th St., New York 21, N. Y.

Kelly & Gruzen, Architects-Engineers, New York office, 80 Fifth Ave., New York 11, N. Y.

George M. D. Lewis, Architect, 445 Kressler Court (off Vine St.), Scranton, Pa.

**Firm Changes**

William E. Brackett, Jr., and M. McDowell Brackett have announced the change of their firm name from William E. Brackett, Jr., Architect, to Brackett & Brackett, Architects. Address: Technical Bldg., Asheville, N. C.

Olof Z. Cervin, A.I.A., until recently a partner in the firm of Cervin & Stuhr, Architects, of Rock Island, Ill., has announced his retirement from architectural practice and his availability to a limited number of clients for advice and counsel. He has established his new office at 3400 10th Ave., Rock Island, Ill., under the name of Olof Z. Cervin, A.I.A., Architectural Consultant.

Lockwood Greene, Engineers, Inc., of New York, has announced the election of Samuel B. Lincoln as president, succeeding Chester S. Allen, elected chairman of the board of directors.

Carroll Martell and Kenneth W. Brooks, both Registered Architects, have announced the formation of a partnership for the general practice of architecture and community planning under the firm name of Martell & Brooks, Architects, with offices in the Fernwell Bldg., Riverside & Stevens, Spokane, Wash.

**ELECTIONS, APPOINTMENTS**

Richard J. Canavan, Architectural Engineer, has been appointed technical secretary of the Producers' Council.

James R. Edmunds, Jr., of Baltimore, a past president of the A.I.A., has been re-elected chairman of the Construction Industry Advisory Council.

**Educational Group Organized**

The North Carolina Architectural Foundation, Inc., a non-stock, non-profit charitable and educational corporation, was organized in January in Chapel Hill, N. C., to promote architectural education and research at North Carolina State College. The Foundation is sponsored by the North Carolina Chapter of the American Institute of Architects. Walter Hook, A.I.A., a member of the sponsoring Chapter, is president of the new organization.

You Design A Building!  
You Engineer A Building!  
You Build A Building!

WHAT FOR?

Beauty?

Stability?

Permanence?

Functional Value?

Ellison, the Balanced Door  
meets these specifications



AND —  
ELLISON is the door that  
lets traffic through QUICKLY

Ellison

ELLISON BRONZE CO.  
Jamestown, New York  
representatives in principal cities

the **BALANCED DOOR**





**CONSERVATIVE GOOD TASTE** characterizes bank modernization today . . . and a strikingly apt medium is ENDURO Stainless Steel—in exterior trim, escalators, stairways, architraves and bank fittings. Banks and financial houses, ultra-conservative in the past, are finding functional design to be a stimulus to better customer relations.

*Enduro-THRIFTY METAL  
OF 10,000 USES*

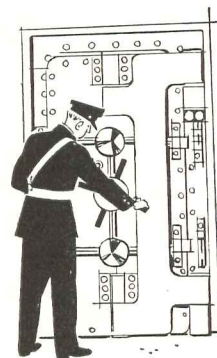

## THE METAL THAT SAYS "COME IN" . . . "KEEP OUT"

Republic ENDURO Stainless Steel . . . one of the most versatile materials at the architect's command . . . lends itself perfectly to functional design, simplicity, good taste, and to the *eye-appeal* that says, "Welcome! We value your patronage!" No less does its obvious strength and toughness, standing guard over architraves and no-admittance areas of the bank proper, tell the prowler, "Keep Out!"

Decoratively, ENDURO's versatility gives full rein to the architect's creative imagination. Its high strength-to-weight ratio makes it practical in thin section, readily contoured, shaped or surface-patterned. Its resistance to

corrosion and its ease of cleaning broaden its applications and make it permanently beautiful. Structurally ENDURO is rugged, lightweight, resistant to heat and cold, has a low coefficient of expansion and possesses unusually long life. It is the *architect's metal!*

If not fully conversant with ALL of ENDURO's characteristics, see Sweet's Architectural File or write today to:

### REPUBLIC STEEL CORPORATION

*Alloy Steel Division • Massillon, Ohio*

**GENERAL OFFICES • CLEVELAND 1, OHIO**  
Export Department: Chrysler Building, New York 17, N. Y.

*Enduro* **STAINLESS STEEL**  
REG. U. S. PAT. OFF.



✓ **Check ALL 10 Advantages:** • RUST AND CORROSION-RESISTANCE • HEAT-RESISTANCE • HIGH STRENGTH • NO METALLIC CONTAMINATION • SANITARY SURFACES • EASY TO CLEAN • EYE APPEAL • EASY TO FABRICATE • LONG LIFE • LOW END COST.



for plywood flats 12 ft. high and up to 5' 9" wide; carpentry shop about 30 x 30 ft. for making stock sets; a large scene studio with paint frame, up to 40 x 80 ft., for setting up and painting sets; rooms for costume storage and possible dyeing and sewing. Sizes noted are for large stations; in smaller plants they might be reduced.

**EQUIPMENT**

**Cameras, Lighting, Electrical System**

Introduction of the new image-orthicon TV camera recently has changed many studio requirements. The old iconoscope camera demanded much higher levels of studio illumination. At the same time, lighting units themselves have been

undergoing change. Current good practice employs a mixture of fluorescent and incandescent lamps in fixtures suspended from a pipe grid which is hung from the studio ceiling; the proportion of each type is the subject of divergent opinions and must be determined for each job. In addition, some portable lamps on standards are used to give roundness to the televised subject. Fixtures are preferably adjustable in direction and height, and although dimmers have not been common, they are included in many recent installations. There is a growing practice of concentrating all responsibility for lighting in one individual, which means some method of remote control for the fixtures. This introduces complex lighting switching; and while some studios have installed catwalks at the level of the ceiling fixtures for manually adjusting lights, in others this is done from ladders. Some lights are adjusted by means of pulleys and cables; sometimes there is a wall-mounted pinrail to which the cables or ropes run. In a TV studio there is no chance to adjust lighting during the performance as there is on the movie stage; once set, the lighting stays. The lighting pipe grid is usually designed to carry 40 lbs. per square ft. of floor area; special tracks, monorails, etc., have also been used, although the need to cut costs may rule these out. Structurally, the ceiling must be capable of supporting the weight of the grid plus weight of fixtures.

To permit utmost flexibility of lighting, a great number of wall receptacles is essential. Three-outlet units ten ft. apart, entirely around the room, are recommended. One authority recommends two rows, one about 2 ft. above the floor, the other slightly below ceiling fixture level; another suggests a single row about 5 ft. above the floor. The studio power load is in the neighborhood of 15 to 25 watts per square ft. of staging area.

Camera cables have to maintain a constant length, so camera plug-ins are often concentrated in one spot, directly under the control room window where they cannot be blocked by scenery. In large studios several locations may be needed. In the control room, wiring may be carried in floor trenches; the same is true of movie-projector units in the film room. Future expansion must be

(Continued on page 180)

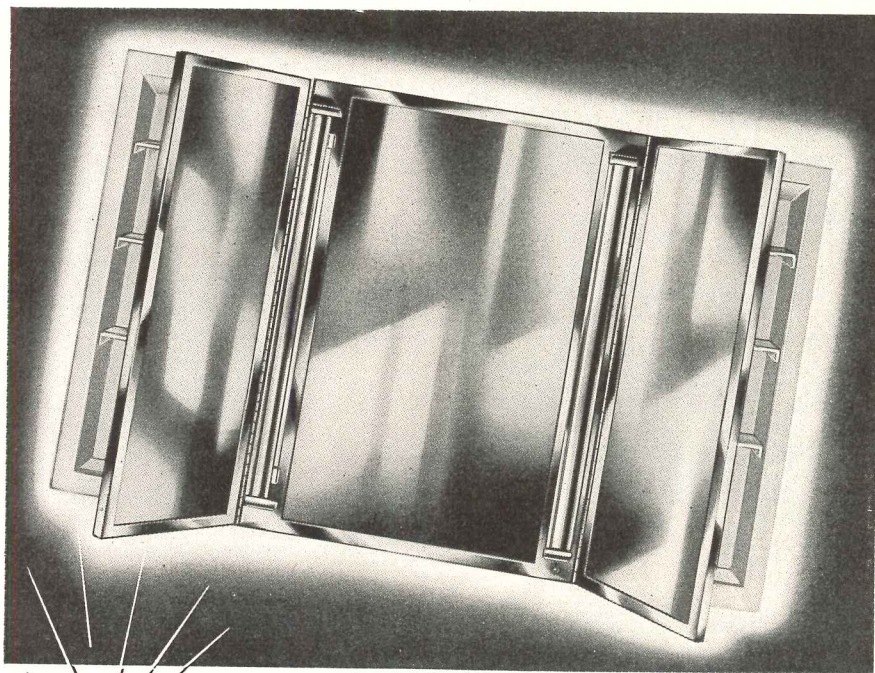

*Your own ideas polished up!*

IT WILL SURPRISE YOU how well your own ideas have been polished up—and how completely they have been incorporated in the designs of the whole Parker Line of bathroom cabinets and accessories. Years of experience have developed Parker's ability to see eye-to-eye with architects in style and utility... just as working with builders has influenced Parker's strict standards of materials and workmanship to meet extreme usage requirements. See the complete line in Sweet's, or send for the new Parker Catalog. The Charles Parker Company, Meriden, Connecticut.

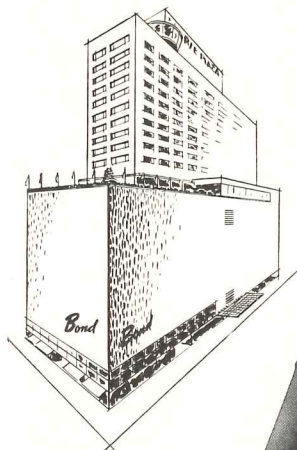

Parker Bathroom Cabinets and Accessories were used throughout Cincinnati's new Terrace Plaza Hotel.

**PARKER**  
**BATHROOM CABINETS AND ACCESSORIES**

# CONNOR

FOREST PRODUCTS SINCE 1872

Manufactured and  
Graded Under  
M.F.M.A. Specifications

## "LAYTITE"

Maple and Birch  
FLOORING

The World's Finest  
— Bar None

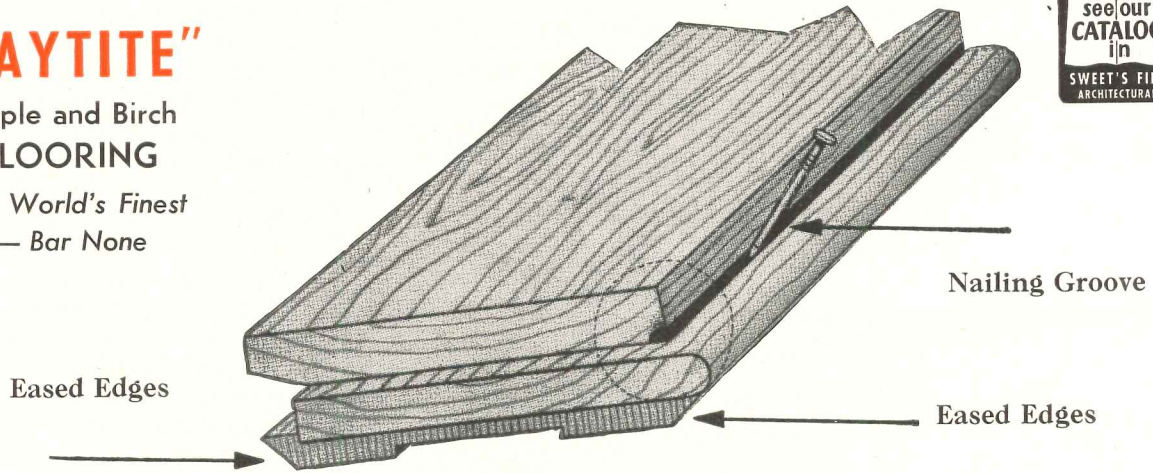

Write for illustrated 75th Anniversary Booklet

## CONNOR LUMBER AND LAND COMPANY

Mixed Cars—Northern Hardwoods, Pine and Hemlock and Flooring

PHONE No. 3

MARSHFIELD, WIS.

P. O. BOX 112-R

Mills: Laona, Wisconsin and Connorville, Michigan

*Behind The Mills — The Connor Timber Stands*

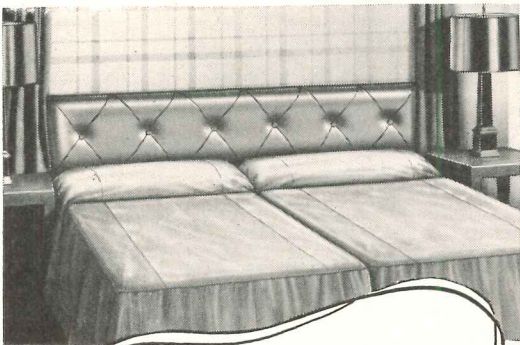

*Distinction  
everywhere*



Outstanding individuality for every interior... Duran in brilliant shades or pale pastels. Upholstery beauty that is superbly grained and finished. Real comfort on all types of furniture. Distinctive too, on restaurant booths and panelling.

For delightful decor use Duran. Specify it for new installations, reupholstering and redecorating. Samples on request.

THE MASLAND DURALEATHER COMPANY  
3236-90 Amber Street • Philadelphia 34, Pa.

considered when such permanent installations are made.

**Air Conditioning and Sound Control**

Air conditioning remains important to TV studios even with the reductions in light levels made possible by the new

cameras. However, the only problems peculiar to TV are sound isolation and air distribution in studios. The air system creates noise or vibration in ducts, at supply and return grilles, and at pumps, compressors or fans. All reciprocating or rotating machinery should

be sound-isolated; flexible connections are desirable between ducts and blowers; ducts are invariably lined with sound-absorbent material and often subdivided internally to reduce noise. Air is distributed at low velocity to eliminate hissing and ducts are oversized, careful attention being paid to design of turning vanes, corners, dampers, etc. Where ducts pass through the structure they are well isolated to prevent noise transmission. In the studio, the portion of the space above lighting fixture level is often not conditioned; directional supply outlets are located below the fixtures. If they did not interfere with mobility and direction of lights, it would be ideal to employ centrally located air supply grilles, but this is so difficult that high wall locations are more common. Return grilles near the floor may be blocked by scenery; nevertheless both floor-level and high-wall returns are used.

In discussing studio design some of the sound control problems have been covered: sound locks, sound-isolating corridors, etc. In the studio the ambient noise level is higher than a radio studio would tolerate, due to sounds from moving scenery, cameras, etc., and to movement and control of personnel. Directional microphones have been developed to cope with this, but it is also advisable to have the studio acoustically as dead as possible. Common practice is to line the entire walls with mineral wool blanket; sometimes alternating panels of live and dead materials are used, but sets, equipment, etc., negate such acoustic refinement. A sensible precaution is to protect the acoustic surfacing with a dado of perforated asbestos board, or at least a handrail. The floor is necessarily acoustically live. Control rooms are acoustically treated, usually to make them as completely dead as possible, sometimes to attempt reproduction of "living room" conditions — but not all TV receivers are in living rooms. Control room and sponsor's booth entrances should have sound locks.

Other equipment problems, such as placing the microphones so they will not cast shadows on the hero's face or the sponsor's product, are not strictly architectural. Nevertheless, the TV operator is so anxious to find solutions that the architect with an idea will find a ready audience.

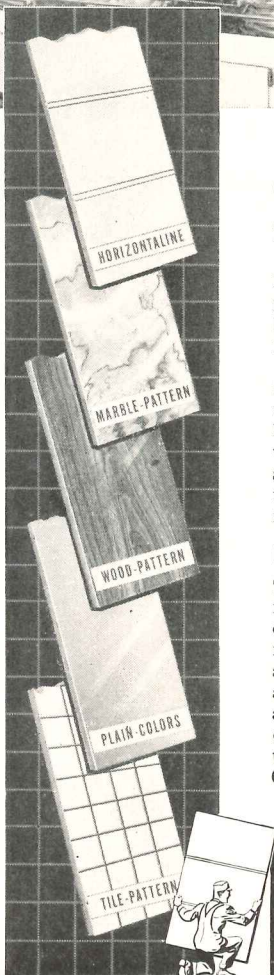

**MODULAR *Marlite* saves money for your clients**

Marlite, the modern plastic-finished wall and ceiling panel, coordinates with other building materials now being used in modular construction . . . to help offer your clients big savings in building costs.

Large, wall-size Marlite panels come in multiples of the standard 4" measurement . . . ranging from 4' x 4' up to 4' x 12'. With beautiful Marlite, you can design luxurious interiors with the 4-ft. plan grid. And the wide range of Marlite patterns and colors makes possible striking, distinctive interiors in homes, stores, theatres, specialty shops, hotels and a host of other installations.

**BEAUTIFUL • PRACTICAL • PERMANENT**

The cost of materials for a Marlite installation has risen less than 15% since 1939! For new construction or modernization, Marlite meets all the requirements for smartness, ease of cleaning and housetime beauty at low installation cost. Sold by all leading lumber and building material dealers. Complete details are available in Sweet's Architectural File—or write today for new, full-color literature. Marsh Wall Products, Inc., subsidiary of Masonite Corporation, Dept. 605, Dover, Ohio.



*for Creating Beautiful Interiors*

# SEE MODINE

and you'll never be satisfied with any other convector

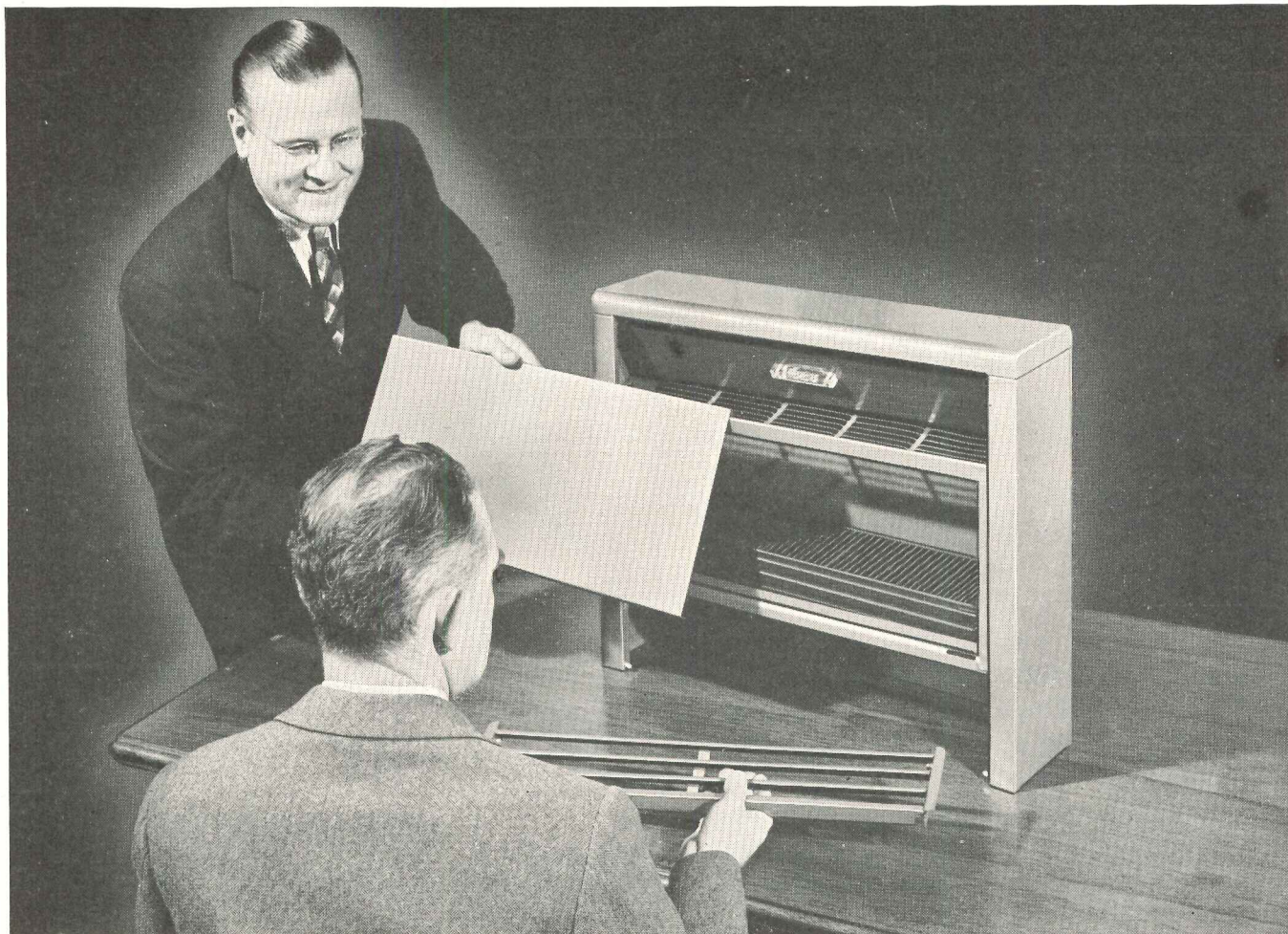

**Once you See it...once you Compare it...you'll know why the Beautiful Modine Convector is its own best salesman!**

ONLY by *seeing* the new Modine Convector\* can you fully appreciate its outstanding new beauty and design. Only by *examining* it can you see why Modine's *exclusive* installation and operating features have people everywhere saying, "You've really got something there." Only by *comparing* it with all other makes can you be sure that Modine is today's number one convector. To help make your decision simpler . . . and more accurate, your local Modine representative or franchised distributor welcomes the opportunity to bring an actual sample of the new Type F convector *right to your office*. Call him today. He's listed in the "Where-to-Buy-it" section of the phone book. Or send in coupon at right. There's no obligation.

*\*Design and Mechanical Patents Pending.*



*See the New Modine Convector . . . right in your office!*

MODINE MANUFACTURING COMPANY  
1510 Dekoven Avenue, Racine, Wisconsin

Yes — I would like to see and examine a Modine Convector in my office. Please ask your representative in my territory to call soon.

Name.....

Address.....

City..... State.....

## *Modine* CONVECTORS

office building McKim provided (it was originally thought to be a temporary structure) was enlarged to twice its size by President Taft, and that was tripled again by Presidents Hoover and Franklin D. Roosevelt. The Roosevelt expansion, designed by Eric Gugler, was forced underground by an outcry against further enlargement of the office wing at the expense of the White House design as a whole. A \$1,600,000 office extension plan advanced by President Truman in 1946

encountered the same opposition and died.

The program for the White House reconstruction today thus writes itself in history and precedent. Fixed national policy, energetically defended by the A.I.A. and other interested civic groups, stands firm against any overblown office development here. The demands of official entertaining absorb the main floor of the White House, and service functions the basement and attic. That

leaves the second floor for the President and his family. What they will get from the present alterations will be a compact, efficient, apartment-type of flat, in which plan some of the historic rooms and their fittings will be preserved. The cabinet room, and the room where Lincoln signed the Emancipation Proclamation would probably be saved, and the oval study as well. There may be some possibilities for providing more living space — a roof garden is among them — but in general the living quarters for the President and his family will have to be accommodated on one floor within the 85 by 170 ft. area of the building. Beyond that one must consider the various proposals that have from time to time been advanced for a "second White House," a suburban or country place up the Potomac toward the mountains but within easy reach of the Capital that would serve the President in relation to the White House somewhat like Chequers in relation to 10 Downing Street.

Now about the \$5,000,000. As Lorenzo S. Winslow, architect of the White House, has pointed out, who knows? It might cost \$8,000,000. Or it might be less. The work that has to be done can only be approximated, even in the stripped state of the building today. It is a kind of architectural dentistry, a beam-by-beam replacement of virtually the entire structure, a completely new mechanical installation, and then a restoration of the appearance of the building as it was before the work commenced. An expensive, uncertain job, to be done on force account — and one that will take an equally uncertain length of time.

Every president has had his hand in some remodeling of the White House, and for 150 years it has been the battleground between the temporary interest of the tenant who wants to make himself at home there for a limited period of time, and the people of the United States who have a continuing interest in the building regardless of its occupant. Whatever solution is arrived at, it is good only until the next administration. To be valid, plans for such a building should provide for flexibility and choice. But neither the political nor the architectural means exist to create a situation in which flexibility and choice are possible. Perhaps making the building a national monument and putting it under the exclusive jurisdiction of the Park Service would help. But until something like that is done, one may confidently expect that the White House will present its bill for remodeling every so often, and the nation should count itself lucky to pay the price.

## It works both ways! Infra Insulation Blocks Wasteful Heat Flow

In summer, Infra compartmented aluminum insulation EXCLUDES 97% of Radiant Heat from the building; in winter, Infra CONFINES 97% of Radiant Heat.

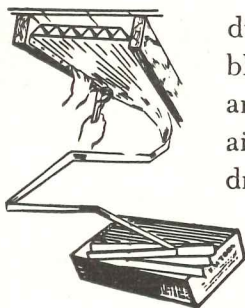

Loss of heat, or its intrusion, through Conduction or Convection, are also effectively blocked. An impermeable barrier to moisture and water vapor, as well as to warm and cold air, is set up. The harboring of mold, fungi, dry rot and vermin is prevented.

Every time you install Infra in a building, you make a generous contribution to the comfort and economy of those who live or work there.

Infra's multiple separated aluminum sheets provide 4 reflective spaces and 4 reflective surfaces, each non-condensation-forming. Two sheets of aluminum and the accordion partition block convection currents. Infra's triangular reflective air spaces and small mass eliminate conduction as a problem.

### INFRA C FACTORS & ROCKWOOL EQUIVALENTS

- C.052 Heat Flow Down, equals 6" Rockwool.
- C.083 Heat Flow Up, equals 4" Rockwool.
- C.10 Lateral Heat, equals 3-1/3" Rockwool.

Thermal Factors Printed on Every Infra Carton

ACCORDION MULTIPLE ALUMINUM &  
TRIANGULAR REFLECTIVE AIR CELLS

**Infra** INSULATION, INC.  
10 Murray St., N. Y., N. Y.

WRITE FOR

**Free**

32-Page

Monograph

"Simplified

Physics of

Thermal

Insulation."

Address Dept.

A.R.

DOOR CLOSERS BY *LCN*  
CLOSERS CONCEALED IN HEAD FRAME  
AMERICAN STOVE COMPANY, ST. LOUIS

LCN CATALOG II-E ON REQUEST

LCN CLOSERS, INC., 466 WEST SUPERIOR STREET,  
CHICAGO 10, ILLINOIS



Harris Armstrong, Architect

(Continued from page 148)

In the main living quarters each room is controlled by its own thermostat. The control in the servants quarters is an outside bulb and inside water temperature control that maintains a very even temperature throughout the apartment.

In the swimming pool, in conjunction with the radiant heating system, there is a fresh air ventilating system which is controlled by the percentage of humidity in the pool room or in the loft

space above the pool ceiling.

The entire project is oil fired. And in addition to the heating, there are snow melting coils used at the front and rear entrances as well as the roof over the swimming pool. Architects were Berninger, Haag and D'Entremont of Jenkintown, Pa.; heating engineer was George A. Heath, Mechanicsburg, Pa. The H. B. Smith Co., 62 Main St., Westfield, Mass.

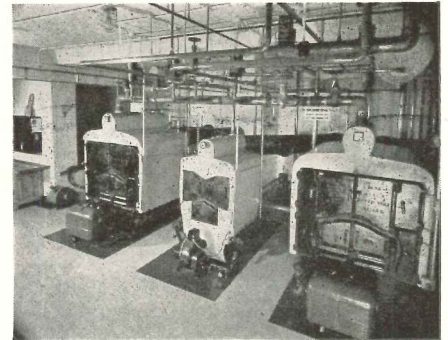

These are just three of six boilers used to heat rooms, swimming pool water and domestic water of a Bloomsburg, Pa. home

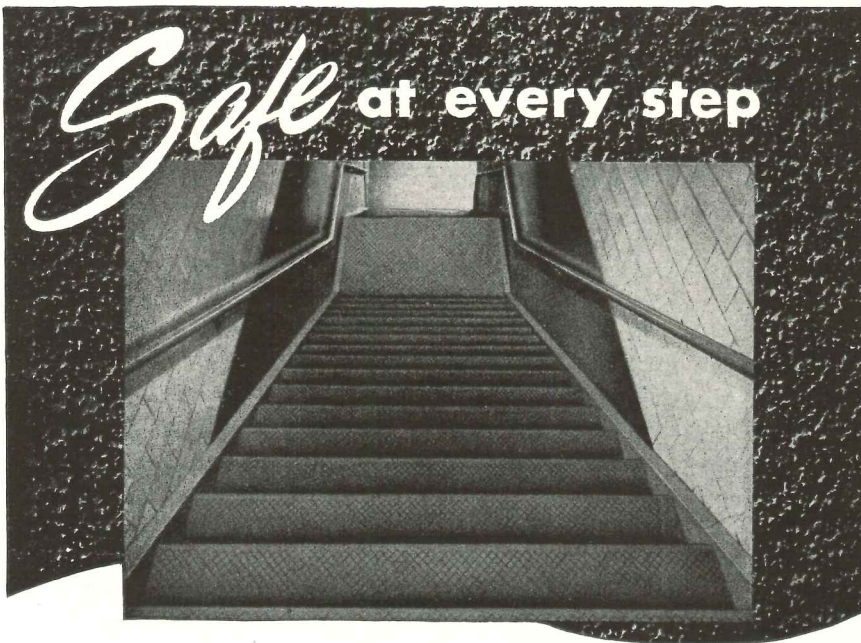

**WITH FERALUN SAFETY TREADS**

Workmen at the Curtiss Wright Plant, Propeller Division, Caldwell, N. J., go up and down these stairs . . . safe at every step.

Their shoe soles come to grips with non-slip Feralun Safety Stair Treads, cast iron, with wear-resistant abrasive embedded right in the walking surface.

Heavy traffic day in, day out — but Feralun Safety Treads, built to take hard use, stay non-slip . . . last and last.

And that means low maintenance . . . and high safety.

**4 TYPES:**

- Cast iron base . . . . . FERALUN
- Bronze base . . . . . BRONZALUN
- Aluminum base . . . . . ALUMALUN
- Nickel bronze base . . . . . NICALUN

**3 SURFACE STYLES:**

- hatched . . . plain . . . fluted

Use coupon below to get our free, illustrated catalog. Also consult Sweet's File, Architectural, 13 a-8.

AMERICAN ABRASIVE METALS CO. (AR-6-49)  
460 Coit Street Irvington, N. J.

Please send me your catalog on non-slip stair treads, floor plates, thresholds, elevator sills, and safety tile.

Please have one of your safety engineers contact me.

Name..... Title.....

Company.....

Street.....

City..... State.....

**LIGHTWEIGHT AGGREGATE**

The lightweight aggregate, perlite, will soon be processed in a new plant being built by the Great Lakes Carbon Corp. in Linden, N. J. It has been produced for several years under the name of *Permalite* in this company's plant at Torrance, Calif., and now operations are being extended to supply the East.

This aggregate is made by expanding perlite, a volcanic rock, at a temperature of approximately 1900F. Permalite varies in density from 5 to 15 lb. per cu. ft., depending upon the end use. Significant advantages claimed for the aggregate are: (1) it is lightweight, (2) it has excellent insulating properties (thermal and acoustic), (3) it has unusual fireproofing qualities, (4) it does not have an affinity for water. The lightweight advantage is said not only to result in reduction of dead load, but also in improved workmanship.

Aggregates are made for plaster and for insulating and fireproofing concrete. The concrete is not a structural type, however, developing a 28-day compressive strength of 400-1000 psi. The manufacturer reports that the lightweight plaster weighs on an average 58% less than sanded plaster.

Permalite plaster aggregate has already been used extensively on the West Coast, in Texas and in the Chicago area. Great Lakes Carbon Corp., 18 E. 48th St., New York 17, N. Y.

**LIGHT SWITCH**

An electric light switch now available is designed to solve the problem of turning on lights in a darkened room. It is equipped with a transparent nylon handle containing a tiny neon light which automatically goes on when the room lights are turned off.

(Continued on page 186)



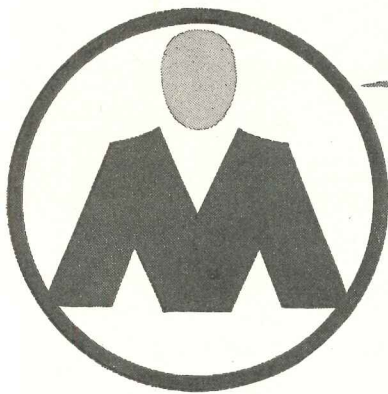

**The Original Mengel Flush Door**  
with the Patented  
**"INSULOK" GRID CORE** →

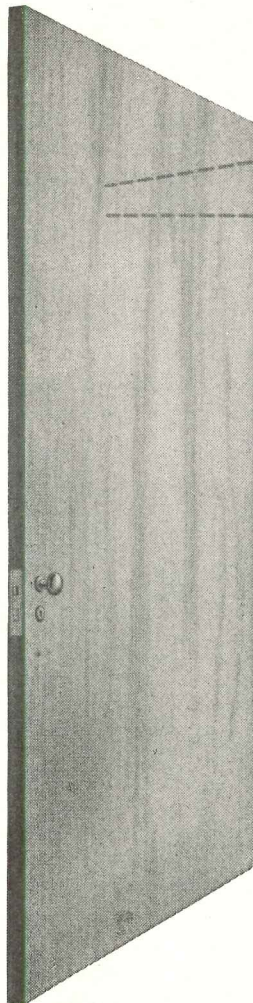

**Through the MENGEL DOOR  
Lies Opportunity for  
MORE BEAUTY...LESS UPKEEP**



It's more than just a beautiful door! It's an approved way of building durability and utility into any interior... regardless of period and decorative scheme.

For Mengel Flush Doors are engineered and built by skilled craftsmen to give *beauty with a purpose*... beauty with fingertip lightness, long, trouble-free life, easy upkeep.

Only the Mengel Flush Door has the patented "Insulok" Grid Core. Made of sturdy insulation board strips halved together, it ends expansion and contraction headaches... makes Mengel Flush Doors much lighter than standard panel hardwood doors.

**Built Like Fine Furniture!** Framing is hard, even-textured poplar. Corner connections have dovetailed lock-joints, securely wedged, to give dimensional stability and seal moisture out. And the 3-ply faces are permanently bonded to frame and core.

No wonder Mengel Doors stand a 25,000-slam test. And every door is "cured" before it leaves the factory to assure warp resistance.

Mengel Flush Doors come faced with beautiful veneers of *Birch, Mahogany, Oak, Walnut, Gumwood* (and other hardwoods to order).

And they *stay* beautiful! Their smooth, unbroken surfaces are easy to clean... offer no place for dust to cling. No panels to shrink... no moldings to come apart.

**Easy to Paint!** The smooth Gumwood door is perfect for painting... never shows a grain raise.

For new construction or remodeling, specify Mengel Flush Doors... the doors with years of performance behind them. For full information mail the coupon *today!*

**The Open-and-Shut Case  
for Mengel Doors**

- 1. An Engineered Door**... with patented "Insulok" Grid Core, hardwood frames and faces, and dovetailed lock-joints.
- 2. 3-Ply Faces Bonded to Core**... with moisture-resistant resin glue by hot-press method.
- 3. 40% Lighter in Weight**... than standard panel hardwood doors.
- 4. Warp-Resistant**... "cured" before leaving factory.
- 5. Slam Tested**... 25,000 times by powerful machine.
- 6. Flame-Resistant Core**... made of 3/8" insulation board.

Copyright 1949, The Mengel Company

- 7. Sealed Construction**... prevents entrance of dirt, vermin or moisture.
- 8. Over-sized Lock Block**... centered on edge of stile, permits reversing door.

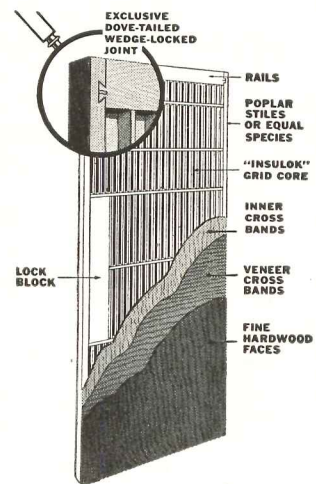

••• Mail Coupon Today! •••

**THE MENGEL COMPANY**  
Plywood Division, Dept. AR-1, Louisville 1, Ky.

Please send me complete information about the Mengel Flush Door.

Name .....

Street .....

City ..... Zone ..... State .....



**MENGEL Flush DOORS**  
THE FAMOUS FLUSH DOOR WITH THE PATENTED CORE

*Glo-Switch* fits the standard wall switch receptacle, and is installed easily with a screwdriver. It operates on leakage normal to any switch, according to the manufacturer, and is said to operate for about three cents a year. *Glo-Switch* Corp., 30 Church St., New York 7, N. Y.

## ACCORDION INSULATION

Accordion type, aluminum reflective insulation, manufactured by *Infra*, is

now available in a strengthened construction. The two aluminum sheets forming the reflective layers now come to the edges of the flanges of the insulation, so that when it is stapled in place, the staples pierce the two layers of aluminum as well as one of fiber. This has been done to eliminate the possibility of separation of aluminum and fiber layers. According to the manufacturer, this insures that the insulation will remain in

(Continued from page 184)

place for the life of the building and provides continued "compartmentation" of the accordion-type insulation. *Infra* Insulation, Inc., 10 Murray St., New York, N. Y.

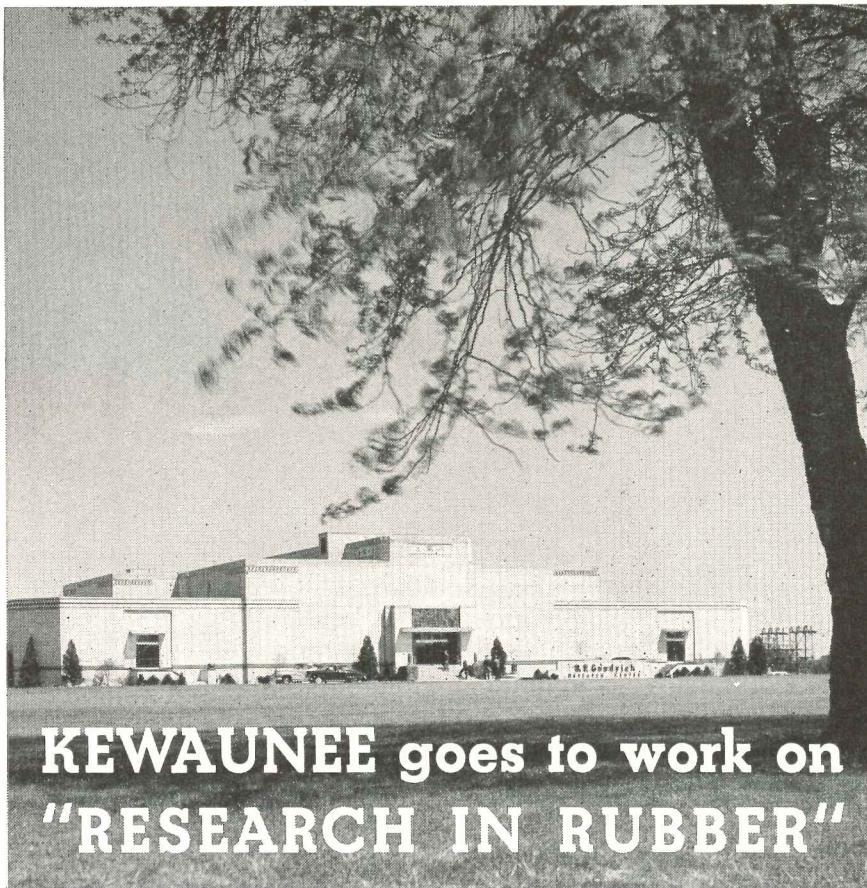

## KEWAUNEE goes to work on "RESEARCH IN RUBBER"

### New B. F. Goodrich Laboratory is Kewaunee Equipped

Kewaunee Laboratory Furniture is designed and engineered to fit practically any industrial research program or laboratory requirement. That's one reason why B. F. Goodrich chose Kewaunee for its new Research Center at Brecksville, Ohio.

The new Kewaunee metal units are heavier and sturdier than ever, with new, huskier door and drawer

suspension. Metal surfaces are Bonderized. Working surfaces are Kewaunee's KemROCK — resistant to acids, alkalies, solvents, and ordinary physical shock.

Through and through, Kewaunee is custom quality — at ready-made prices. Write for full details. No obligation.

*Kewaunee Mfg. Co.*

C. G. Campbell, President

5046 S. Center St., Adrian, Michigan

Representatives in Principal Cities

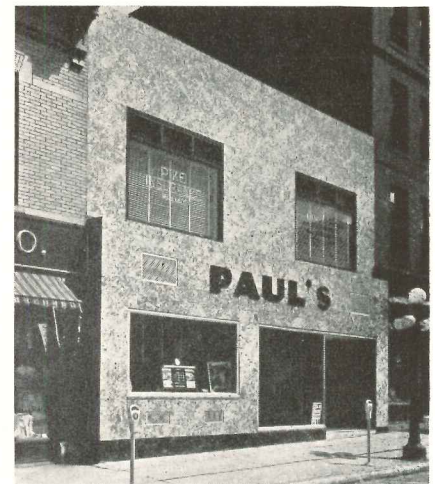

Marble front of the store shown was set with plastic adhesive instead of anchors

## MARBLE SET WITH ADHESIVE

Marble is being placed in line with other building materials and equipment in an endeavor to reduce building costs through use of a plastic adhesive for setting the material.

The Marble Institute of America describes this "plasticized synthetic resin bonding cement" as a black (or dark) material, impervious to moisture; not affected by normal heat or cold; adhering with a strong suction to all clean surfaces without sagging; setting to a stiff plastic state, capable of absorbing moderate shock or settlement; not bleeding through  $\frac{7}{8}$  in. marble.

Damage to wall backing and spoilage are said to be eliminated since normally no anchors are necessary in setting marble 2 in. or less in thickness with the adhesive. According to the Marble Institute, it is especially desirable where setting space is tight or at points where anchoring is difficult.

The Marble Institute points out that the marble industry has not shifted suddenly from conventional practice, many contractors preferring the plaster of Paris "spots" method. But they say that many firms have found labor and material costs to be less by the new method.

Tests have shown that the plastic adhesive holds up under rugged tests. In one test, three slabs  $2\frac{1}{2}$  ft. wide by  $5\frac{1}{2}$  ft. high, which set two days before

(Continued on page 188)

# TRANE

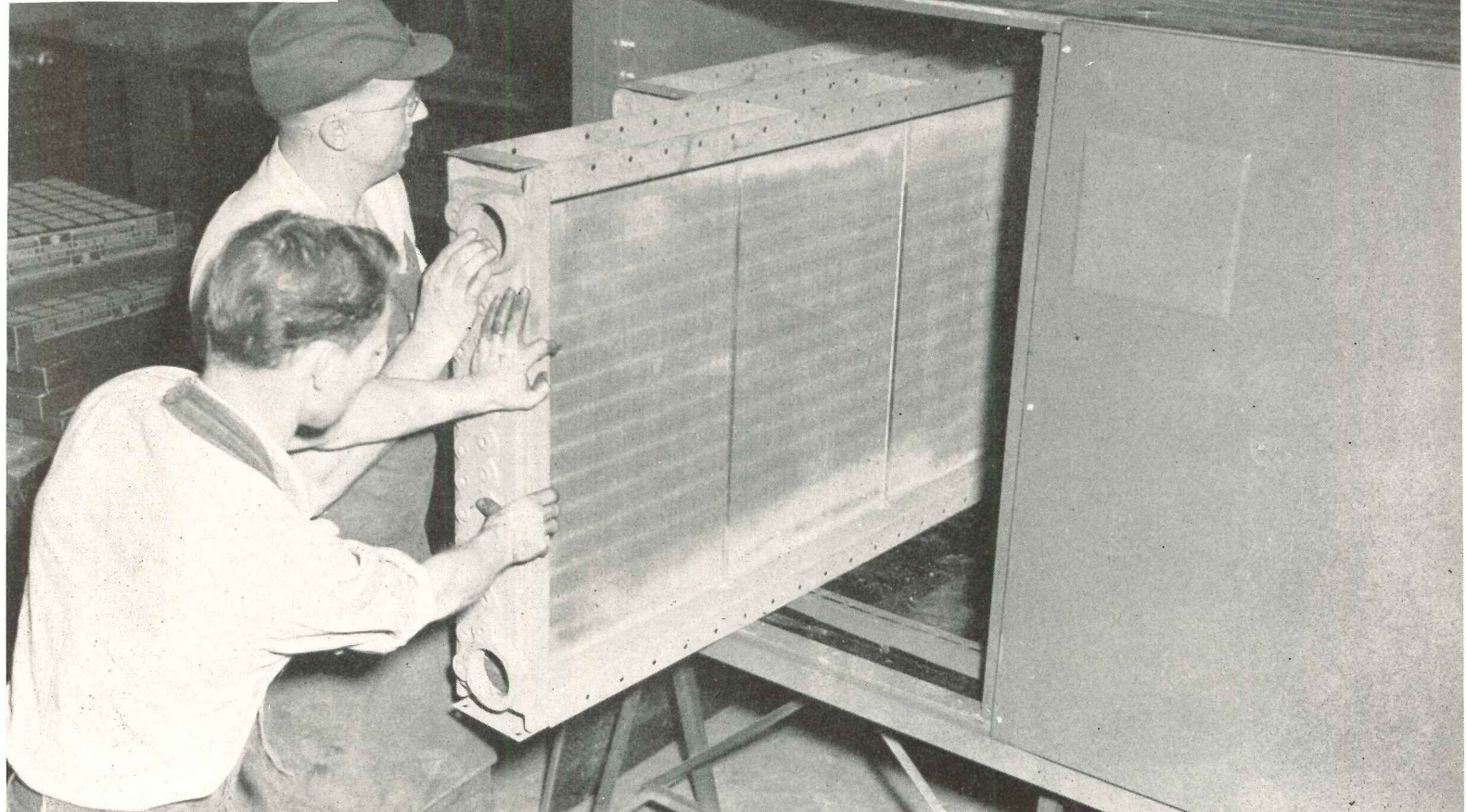

*It's easy to install coils in a Climate Changer. Workmen here are slipping a standard 2-row, Type C Heating Coil into place.*

## Extra room for extra coils to meet your future needs

An engineer recently remarked that, "one of the best advantages Trane has in Climate Changers is that there's always room in them for more coils."

Maximum coil capacity of a standard Climate Changer is ten rows of tubes. Usually only a 1- or a 2-row heating coil is needed, with a 6-row cooling coil—so actually there usually is "room for more coils." Also, the scheme of "heating coils now—cooling coils later" is popular.

That extra space for extra coils to meet your future needs is always good job insurance. It saves dollars, and it saves headaches.

Having the right extra spaces in the most important places is typical of many features that have been engineered into this husky, heavy-duty air conditioner.

We sincerely believe the Climate Changer is not only the

most flexible, most versatile air conditioning unit built, but also that it will last longer with less care and attention than any other similar device.

Ask the Trane sales office in your area to show you how Climate Changers are being used to meet heating, ventilating and air conditioning needs, for comfort or process work—domestic, commercial, industrial. Sales office Weather Magic files contain an impressive number of case histories.

### THE TRANE COMPANY . . . LA CROSSE, WIS.

Manufacturing Engineers of Heating, Ventilating and Air Conditioning Equipment—Unit Heaters, Convector-radiators, Heating and Cooling Coils, Fans, Compressors, Air Conditioners, Unit Ventilators, Special Heat Exchange Equipment, Steam and Hot Water Heating Specialties . . . IN CANADA, TRANE COMPANY OF CANADA, LTD., TORONTO.

An endless variety of sizes and styles of Climate Changers, vertical (1) and horizontal (2); along with Evaporative Condensers (3); Compressor Units (4); and Turbo-vacuum Compressors (5); are typical of the broad Trane line.

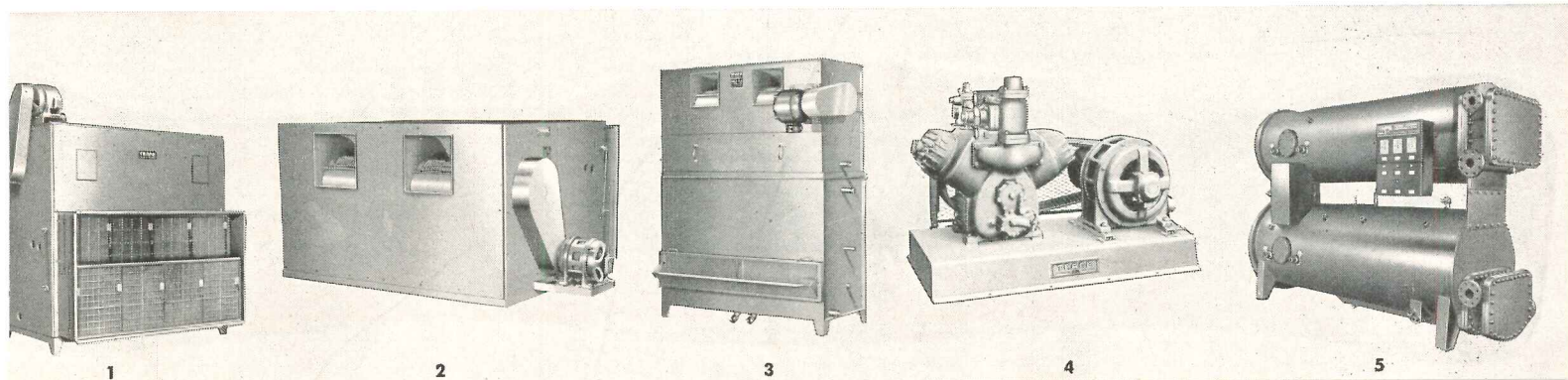

(Continued from page 186)

being subjected to a load, did not come loose until a load of 216 lb. (average) was applied. After 30 days it took 336 lbs. Marble Institute of America, Inc., 108 Forster Ave., Mount Vernon, N. Y.

## PANEL FASTENER

A butt-joint panel fastener, recently developed, is now being used extensively in conjunction with honeycomb or other sandwich-type materials, as well as ply-

wood, fiber board and other sheet materials to form movable partitions, portable shelters and demountable boxes.

The principal feature of the *Roto-Lock* is its tapered cam design — no spring or delicate mechanical parts are used. The design of the fastener is such that it can be used to attach vertical to horizontal panels, or to attach panels edge-to-edge.

The manufacturer lists operational features as follows: (1) the lock will

draw panels together at sufficient pressure to establish an air- and water-tight seal, and will carry a 1400 lb. tension load as well as heavy shear loads; (2) it will fasten in misaligned conditions in all directions, and will lock panels in a semi-open position if there is an obstruction between them; (3) it recesses com-

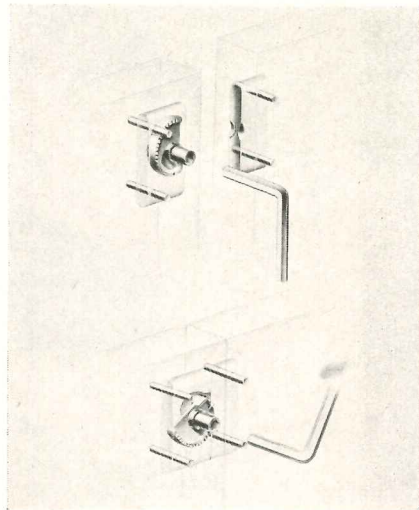

Turning a hex wrench moves a tapered cam of this panel fastener, which locks it

pletely into the panels or for applications to thin sheets it may be side-mounted; (4) the cam may be actuated by a hex wrench, screwdriver or any other hand tool; (5) the assembly consists of no through parts to permit transmittal of heat or cold from exterior to interior surface. Simmons Fastener Corp., Albany, N. Y.

## GLARE-CONTROL LENSES

The problem of brightness control with artificial lighting has received considerable attention in recent years and has resulted in a variety of methods to reduce glare. At the recent lighting show in Chicago the Holophane Co. introduced a series of lenses said to have built-in glare control, directing light rays away from the occupants' eyes toward the work.

The lenses, available in flat or dished shapes, are designed to be used with fluorescent lamps. When the dished lenses are used, some light goes directly to the ceiling to reduce contrast between the lens and background. One curved type is built in a 10 $\frac{7}{8}$  in. width so as to fit acoustical ceiling constructions. This same lens slopes back to the ceiling at the end of a run so that no metal end pieces are needed. Holophane Co., Inc., 342 Madison Ave., New York 17, N. Y.

(Continued on page 190)



# The Barcol OVERdoor

This large door on a municipal building, used for an exit by heavy road machines, is *hand-operated* — demonstrating the easy-working quality of the Barcol OVERdoor even in big sizes.



## Easy-Working!

The simplest and surest way to tell how well the Barcol OVERdoor works is... *work it*. Raise it... lower it. Note the roller-bearing glide of the sections... upward and downward. *No other overhead door works any easier!*

SEE OUR  
CATALOG  
IN SWEET'S

## Weather-tight!

To keep out weather, a door must close snugly... and a really snug door *won't rattle*. So... take hold of the handle on that same door that closed so easily... and try to rattle it. You can't... because the *exclusive closing action* of the Barcol OVERdoor insures all-around weather-tightness... and easy operation!



FACTORY-TRAINED SALES and SERVICE REPRESENTATIVES in PRINCIPAL CITIES



**BARBER-COLMAN COMPANY**  
102 MILL ST. • ROCKFORD, ILLINOIS

Nothing is a problem...  
to the amazing new

# CUSHIONLOK by Bigelow



## Time is no problem

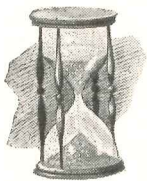

This revolutionary new commercial carpet, with its built-in rubber cushion, requires no time-taking workroom preparation.

Cushionlok cements directly to concrete, wood, or plywood floors. (Seams are almost invisible.) Can be walked on immediately!

## Disruption is no problem



Your *Cushionlok* installation can be accomplished neatly as well as speedily.

Because Cushionlok is made in 27" width, only one section of floor is tied up at a time. Fixtures and furniture need only be shifted aside; business can go on as usual!

## Even Cigarette Burns are no problem

Cushionlok's springy wool surface is so handsome you hate to think of the inevitable cigarette scars.

But when you *do* get a cigarette burn, you needn't worry.

Because here's another *Cushionlok* miracle that will make the scar disappear like magic:



**1. Dropped cigarette** smolders unsightly mark in Cushionlok installation. (With ordinary carpet this would be a real tragedy.)

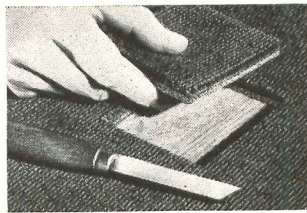

**2. Simple cutting** operation removes marred section. (Experts can complete repair in 5 minutes.)

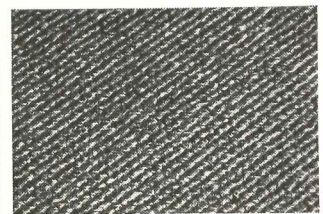

**3. New, small patch** of *Cushionlok* is cemented into place; only an expert could spot the substitution; installation looks flawless.

**Plan your Cushionlok installation now!** You'll find Cushionlok's special features—its smart looped surface, its built-in rubber base—ideal for your commercial installation. Adds luxury underfoot; adds years of wear, yet costs very little more than ordinary carpeting.

Inquire of your architect or decorator, or call Bigelow's Carpet Counsel direct. One of the 25 offices is near you.



# Bigelow

## Rugs and Carpets

Beauty you can see... quality you can trust... since 1825

(Continued from page 188)

## CORK FLOOR COVERING

Research to develop a flooring that would combine the recognized advantages of cork and a tough plastic resin have resulted in *Dodge Vinyl Cork Flooring*, now available in a variety of colors and tile sizes. Results of tests reported by the manufacturer are: (1) it is extremely safe to walk on, having a high coefficient of friction when dry, and an

even higher one when wet; (2) it is quiet to walk on; (3) it doesn't warp, expand or contract with changes in temperature and humidity; (4) it is long wearing; (5) inks, greases, acids and mild alkalis will not mar the surface; (6) it is fire-resistant; (7) has high insulating properties; (8) colors are fade proof; (9) chairs, heavy furniture will not leave permanent marks; (10) it is water-repellent.

The flooring is being made in 21 plain

and marbled combinations of seven basic colors. Tile comes in squares of 6, 9 and 12 in. and in  $\frac{1}{8}$ ,  $\frac{3}{16}$  and  $\frac{1}{4}$  in. thicknesses. Dodge Cork Co., Inc., Lancaster, Pa.

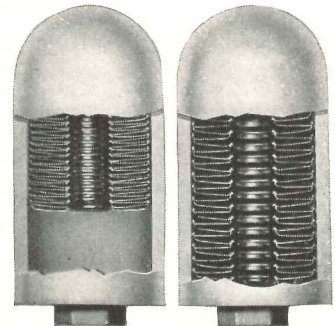

Metal bellows expands, contracts to prevent damaging effects of water hammer

## WATER HAMMER ARRESTING DEVICE

Described as a device designed to eliminate the damaging effects of water hammer in industrial or domestic applications, *ShokStop* is a metal bellows which allows free contraction and expansion of the air sealed within it but prevents all contact between air and water.

Advantages claimed for *ShokStop* include ease of installation and elimination of all maintenance or servicing. It is designed to eliminate the need for capped pipe air chambers which are said to become water-logged and inoperative, and to require frequent maintenance even when provided with valves or petcocks for drainage. Wade Mfg. Co., Elgin, Ill.

## JOINT FILLER

*Kork-Pak* is a resilient, pre-molded joint filler for use between the concrete floor slab and footings of basementless houses and other buildings where a concrete slab is on grade. Used here, it is said to keep the joint filled effectively and to act as an efficient insulating material, preventing heat loss from the slab out through the footings.

The filler is made of cork granules, bonded together with asphalt, between two layers of asphalt-saturated paper. *Kork-Pak* is claimed to keep the joint between the slab and footings filled through repeated expansion and contraction cycles, and in addition to exclude moisture and vapor.

The material is supplied in  $\frac{1}{4}$ ,  $\frac{3}{8}$ ,  $\frac{1}{2}$ ,  $\frac{3}{4}$  and 1 in. thicknesses, in widths up to

(Continued on page 192)

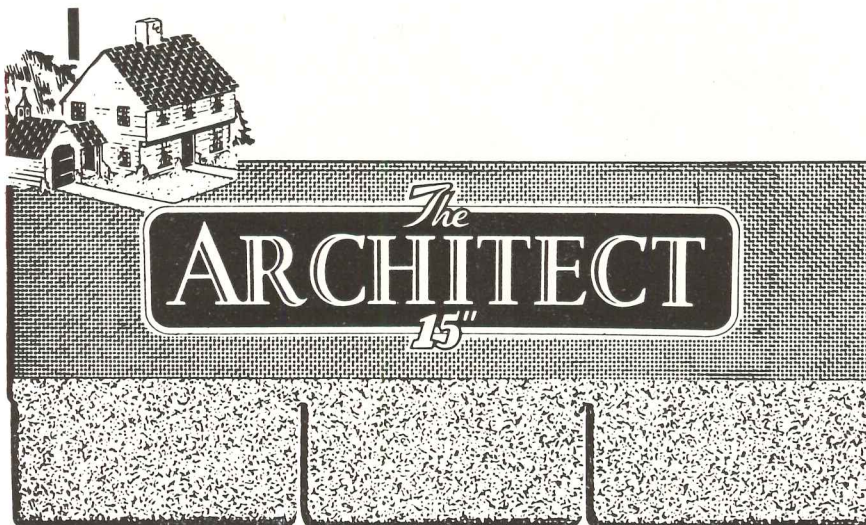

*No other manufacturer  
makes a shingle like this!*

Here are exclusive Architect shingle features . . . features designed by Bird & Son to give this luxurious shingle greater rigidity, greater thickness and longer life:

**Thick massive butts . . .** approximating wood or slate shingles in caliper . . . heavy rich shadowlines.

**Weight 290 pounds per square . . .** a perfect balance of heavier asphalt coating and greater saturation.

**Triple coverage, 5" headlap . . .** longer life and extra protection against standing snow, driving wind and rains.

**Greater rigidity . . .** heavier felt base, more asphalt, and larger mineral granules.

**Surfaced with coarse mineral granules . . .** rich color and new distinction . . . better adhesion and longer surface protection.

**Cost of the Architect is in the asphalt shingle price range . . .** extra value for every building budget.

Write us today for folder showing the wide variety of colors and blends. Bird & Son, inc., 15 High St., East Walpole, Mass.

For similar features in a fine granule shingle, write our Chicago office about #27 Master-Bilts, Dept. AR-2, 1472 W 76th St., Chicago 20, Ill.



East Walpole, Mass.

# Why Pipe Heat All Over?

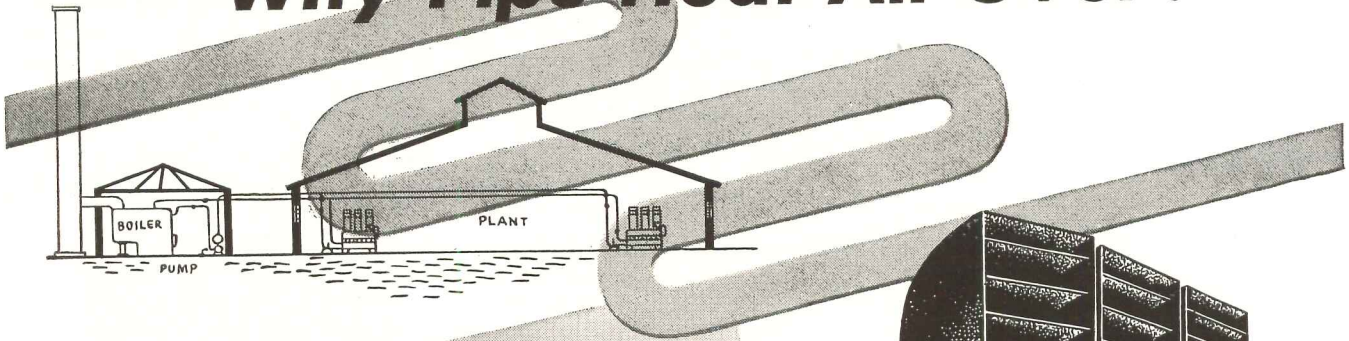

**DRAVO**

*Counterflo* **HEATERS**

make it where  
it's used...

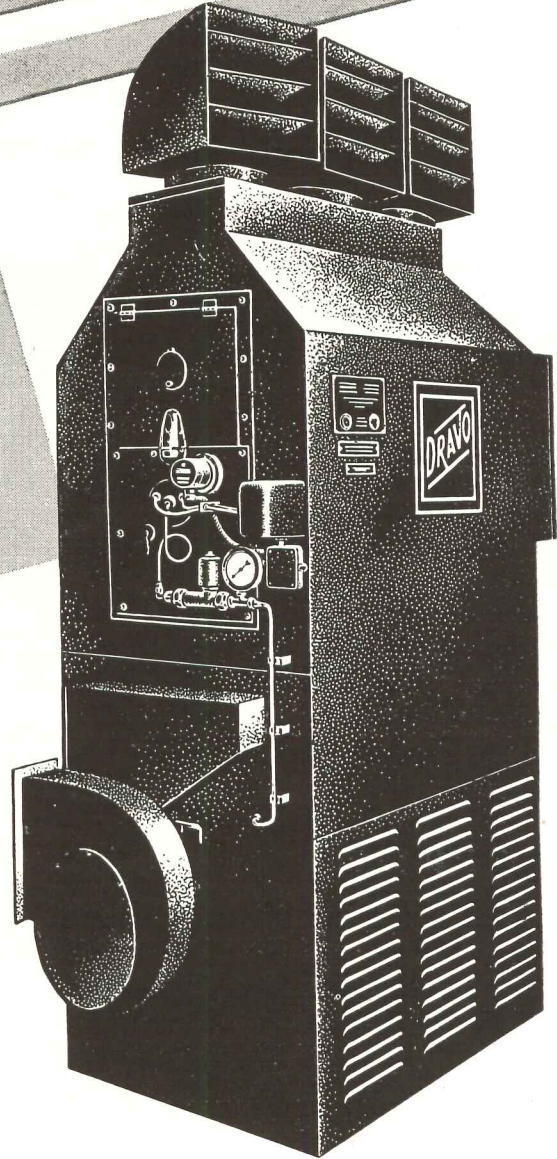

Why waste cash on costly distribution systems to pipe heat all over your plant? Dravo *Counterflo* Heaters *make it right where it's used*, blanket working areas of 4,000 to 20,000 sq. ft. per unit with production-stimulating warm air.

*Counterflo* Heaters also provide ventilating air in summer. 100-150-foot air throw; no ducts needed for large open areas. Oil or gas-fired, readily converted. Reported total installed cost 50 to 66% less than wet-type systems. 80-85% efficiency. Only power, fuel and vent connections required for installation. Stainless steel combustion chamber, rugged mill-type construction, AGA approved and UL listed. Ask for Bulletin DF-523-46

**DRAVO**  
CORPORATION  
DRAVO BUILDING, PITTSBURGH 22, PA.

Dravo also manufactures the *DRAVO CRANE CAB COOLER* for air conditioning hot-metal crane cabs.

PITTSBURGH • CLEVELAND • PHILADELPHIA • DETROIT • NEW YORK • CHICAGO • ATLANTA • BOSTON

Sales Representatives in Principal Cities. Mfd. and Sold in Canada by Marine Industries, Ltd., Sorel, Quebec.



36 in. and in any length desired  
Servicised Products Corp., 6051 W.  
65th St., Chicago, Ill.

### INDIRECT LUMINAIRE

The *Seelex Luminaire*, designed for use with silver bowl lamps, has louvers of spun aluminum with a fine emery-grained finish. The silver bowl lamp used in this indirect luminaire contains the major reflector, and the fixture can be

restored to original efficiency merely by a lamp change. Open louvers are said to eliminate the critical maintenance problems usually involved with indirect fixtures. Edwin F. Guth Co., 2615 Washington Blvd., St. Louis 3, Mo.

### VITREOUS CHINA LAVATORIES

A new line of vitreous china lavatories comes in two types — one with a modern shelf at the back (supply fittings are

mounted on the back face of the bowl) and the other with a convenient ledge at the back on which the supply fitting is mounted.

Each lavatory has a dual front overflow which gets rid of the bulge often found at the front of bowls. Extra room is provided at the back for connecting the water supply.

Other features include: wide anti-splash rim, no-slip towel bars which attach on the sides, positive drain control and large capacity. Briggs Mfg. Co., Detroit 11, Mich.



## 3 GYMS IN ONE

From Coast to Coast the HORN FOLDING BLEACHERS AND HORN FOLDING PARTITIONS are making one Gym do the job of three. With emphasis on careful planning Horn offers a "tested" solution to gym problems.

### HORN FOLDING BLEACHERS-HORN FOLDING PARTITIONS

HORN, with years of experience and skill, offers to every school planner the services of the Horn Engineering Department. Horn installations are guaranteed.

WRITE FOR COMPLETE DETAILS AND LITERATURE.

THERE IS NO OBLIGATION.

## HORN BROTHERS CO.

A DIVISION OF HORN INDUSTRIES

FORT DODGE, IOWA



ESTABLISHED 1909

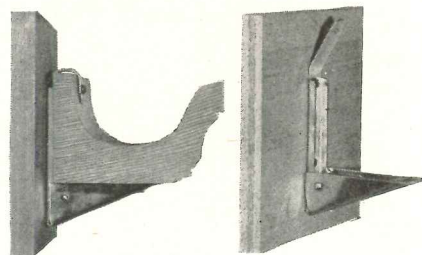

Gutter brackets of aluminum allow space for overflow between gutter and house

### ALUMINUM GUTTER BRACKET

Aluminum brackets are now available designed not only to support wooden gutters, but also to allow space for overflow between the gutter and the house, and thus are said to protect wooden gutters and fascia boards from rotting.

*Unico* brackets, built of aluminum channels permanently riveted together, are attached with screws and spaced 5 to 6 ft. apart. Unico, Huntington, Long Island, N. Y.

### ADJUSTABLE DRAFTING CHAIR

Incorporated into *Tru-Posture Chairs* is an instantaneous adjustment feature by which 7-in. height adjustments can be made by a light pull upward on the seats. The backrests may be raised or lowered, pushed forward or backward, or regulated to any degree of tension desired.

The chairs are of electrically welded steel construction, upholstered in attractive Vinyl-coated leatherette. Models are available with seat heights starting at 17, 20, 22, 24 and 27 in. Dependable Mfg. Co., Omaha, Nebr.

### PAINT FOR GALVANIZED METAL

Galvanized metal surfaces which have heretofore required weathering or chemical treatment before paint could be applied with a successful bond can be fin-

(Continued on page 194)



# AMERICAN-Standard

First in heating...first in plumbing



Architects: Kaiser, Neal and Reid, Pittsburgh, Pa.  
 General Contractor: John McShain, Inc., Philadelphia, Pa.  
 Heating and Plumbing Contractor: Standard Engineering Co.  
 Washington, D. C.  
 Wholesale Distributor: Hajoca Corp., Arlington, Va.

## Georgetown University Hospital selects AMERICAN-Standard

■ Another large new hospital joins the impressive, growing group of institutions selecting American-Standard.

But Georgetown University Hospital's choice of these nationally famous products is not unusual. For no manufacturer offers a wider variety of heating equipment and plumbing fixtures. And none makes a better product.

Yes, when you select or recommend American-Standard you can be sure they will give lasting client satisfaction . . . in efficient performance, economical service . . . and easy, low-cost maintenance. Your Heating and Plumbing Contractor will be glad to furnish full information about the complete American-Standard line. **American Radiator & Standard Sanitary Corporation**, P. O. Box 1226, Pittsburgh 30, Pa.

A Utility Room in the new Georgetown University Hospital featuring **SERVICE SINK** of sturdy cast iron, finished with acid-resisting enamel. Also shown is **CLINIC SERVICE SINK** of genuine vitreous china with quiet, thorough syphon jet flushing action.

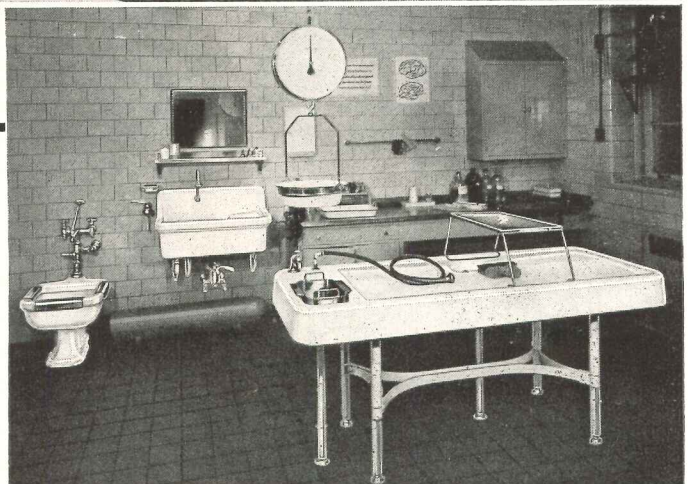

This Autopsy Room in the new Georgetown University Hospital includes genuine vitreous china **ALL-SERVICE SINK** with drain shelf and knee-action mixing valve. **AUTOPSY TABLE** is made of acid-resisting enameled cast iron and has two slab drains, integral sink basin. **ARCO MULTIFIN CONVECTOR**, at right, heats air as it passes between the convector's light, non-ferrous fins. With an **AMERICAN ENCLOSURE**, it makes an attractive, space-saving installation.



Look for this *Mark of Merit*

*Serving home and industry*

AMERICAN-STANDARD • AMERICAN BLOWER • CHURCH SEATS • DETROIT LUBRICATOR • KEWANEE BOILER • ROSS HEATER • TONAWANDA IRON

ished immediately with a new paint called *Quon-Kole*. This new paint is specially compounded with a linseed oil base to react chemically with zinc on new galvanized surfaces, forming a tightly bonded coat without the need of a primer. It is made in white, cream, red, green and gray shades by Sherwin-Williams for the Great Lakes Steel Corp., manufacturer of Quonset structures, and is available through their

local representatives. Great Lakes Steel Corp., Stran-Steel Div., 3750 Penobscot Bldg., Detroit 26, Mich.

### SUBFLOORING INSTALLED WITH ADHESIVE

Plank subbase can be cemented directly to concrete with a special adhesive in a new process developed by Armstrong Cork Co. This method, in addition to eliminating the need for sleepers,

is reported to result in a more secure floor.

This development is said to have special significance in the textile industry where sleepers are imbedded in asphalt or concrete with plank subbase nailed to the sleepers and maple flooring nailed to the planking. Asphalt has undesirable



Special adhesive cements subflooring to concrete, eliminates need for sleepers

dimensional changes, and sleepers imbedded in concrete are difficult to replace if rotted.

The use of the new adhesive forms a moisture barrier between the concrete and the wood as well as anchoring the planking. Armstrong Cork Co., Lancaster, Pa.

### STEEL DOOR FRAME

An all-welded, interior-exterior steel door frame for residential or commercial use, now in production, is said to be warp-proof and to combine durability and fire resistance with economy of cost and installation.

The frame, shipped as a complete unit, is made with extra reinforcement in all corners of the mitered joints, a completely enclosed deep dust box, and universal adjustable brass strike plate. Frames are shipped with a spreader bar at the bottom for protection.

Each frame is clearly marked as to size, jamb depth and swing, and is designed for 1 $\frac{3}{4}$  and 1 $\frac{3}{8}$  in. doors. When required, exterior frames are provided with screen door hinges. The Steelcraft Mfg. Co., Rossmoyne, Ohio.

### COMBINED ELECTRIC RANGE, WATER HEATER

Included in a combination electric range and water heater are two full-sized cooking units, a 220 v roaster-baker, an auxiliary outlet operating on 110 v, and a 30 gal. water heater automatically controlled by adjustable thermostats.

(Continued on page 196)

## FOR friendly weather and functional interiors...

Only the imagination of the designer limits the adaptation of the Win-Dor System of Jalousie Hardware in an infinite number of beautiful and practical plans for living areas.

### New Use For Glass

Here is the modern method of handling light and air...broadening the architect's scope... a practical solution for the protected outdoor living room with clear or obscure glass slats. Glass louvres are easily and conveniently operated and have integral weatherstripping.

### Indoor Jalousie Benefits

In temperate climates where summer is most keenly enjoyed, Win-Dor Jalousies and Jalousie doors supplant solid partitioning with ventilated walls and doors. Positive operating control. The same superior mechanical system also available for Jalousie windows and doors with wood slats.

See the WIN-DOR Catalog in Sweet's  $\frac{18F}{1}$  and write us

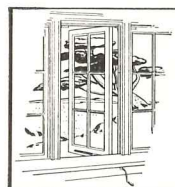
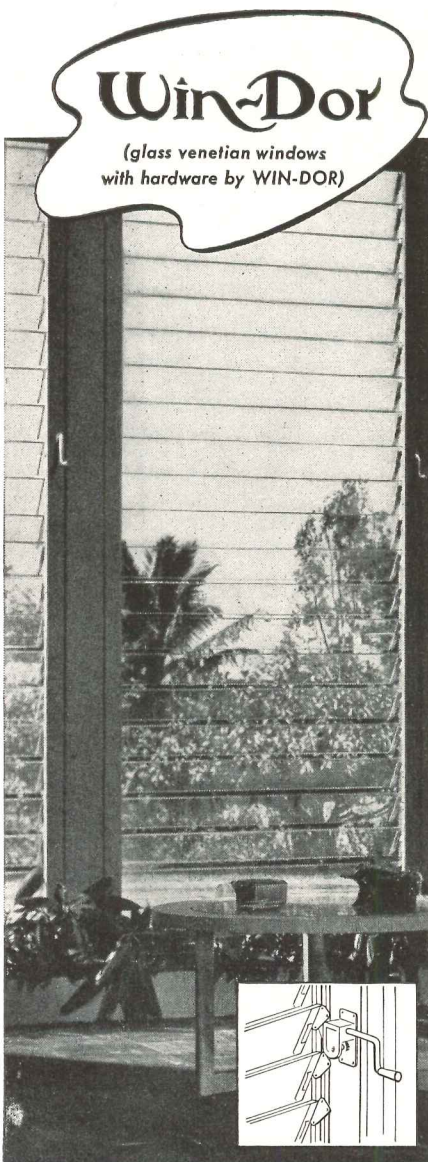

Good wood casements again available, are most efficient with WIN-DOR Casement Hardware.

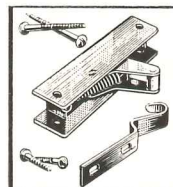

Automatic door closing is at its best with the "automatic hand"—the WIN-DOR Snugger.



CASEMENT HARDWARE CO. • 406 N. Wood St., Chicago 22, Ill., Dept. J

Gentlemen:

I would be interested in receiving detailed information on the following:

Win-Dor Jalousie Hardware  Win-Dor Casement Hardware   
Win-Dor Snuggers

Name.....  
Title.....  
Address.....  
City..... Zone..... State.....



FOR APPEARANCE...Homasote Big Sheets insulate and cover the average wall in one piece, ceilings in two pieces. You have no batten strips, fewer wall joints...and the ideal base for paint or wallpaper . . . FOR STRUCTURAL ADVANTAGES . . . Homasote Big Sheets mean greater strength...As sheathing, for example, Homasote Big Sheets are 272% stronger than conventional horizontal wood sheathing . . . And with many fewer joints, the insulating value is far higher.

**How many operations to sheathe one wall?**

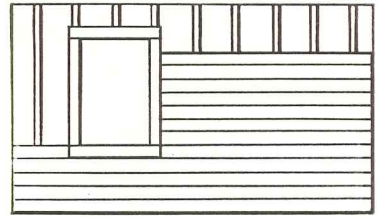

With 6" material—16 pieces in 8' of wall height

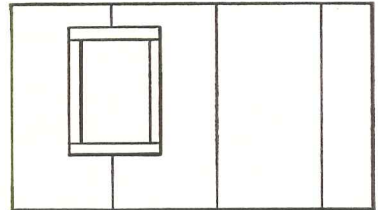

With 4' x 8' material—3½ pieces in 14' of wall length

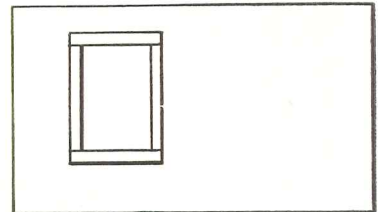

With 8' x 14' material—one piece covers 112 sq. ft. You handle many fewer pieces of material and drive several hundred fewer nails.



up to 8' x 14'

We invite architects and builders to send for illustrated booklet—giving physical characteristics, performance charts, specification data and application instructions.



*Weatherproof*

**HOMASOTE**  
INSULATING AND BUILDING BOARD

HOMASOTE COMPANY, TRENTON 3, NEW JERSEY

The unit is compact, measuring 34 in. long, 36 in. high (cabinet height) and 21 in. deep. Piping is concentrated and is reached for installation and service through a large, removable access panel on the front. Water pipe connections can be made with piping coming through the floor into the cabinet or entering through the rear from the wall. Provision is made for pressure and/or temperature relief valve. Wal-

dorf Heater Co., 1421 Chestnut St., Philadelphia 2, Pa.

### ELECTRICAL RECEPTACLE

A new safety-type, electrical wall receptacle has been engineered to reduce the possibility of accidental shock and burn caused by the insertion of small metal parts, such as knife blades and wires. The *Hubbell SP-49 Receptacle* operates in the conventional manner,

except electrical contact is made only when standard or polarized plugs are inserted.

The heart of the unit consists of four insulated rollers, two of which have to be engaged simultaneously to energize the unit. The rollers are located in a manner to prevent activation with metal objects other than the standard cap.

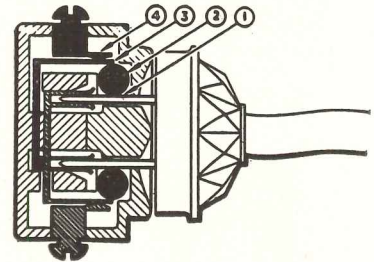

*Safety-type wall receptacle is designed so that just conventional plugs will actuate rubber rollers, thus making contact*

Designed to permit speedy installation is a strip gauge on the back which shows the exact amount of insulation to be removed. Harvey Hubbell, Inc., Bridgeport, Conn.

### NON-METALLIC SHEATHED CABLE

Time required to prepare non-metallic sheathed cable for stripping is reported cut 80 per cent with the improved *Glazon Triex* cable. The Triex construction eliminates the customary individual wrapping over each wire, and instead of 2/64 in. rubber insulation on smaller sizes (14 and 12), 4/64 in. thickness is now applied to the tinned copper conductors.

Advantages claimed are: greater tensile strength, smoother finish, greater moisture resistance, greater dielectric strength, greater impact resistance, further protection from fungus and rot, and increased resistance to fire. Triangle Conduit & Cable Co., Inc., 1923 Jersey Ave., New Brunswick, N. J.

### GAS-FIRED HEATER

Designed to fit in the walls of tourist cabins is a gas-fired *Radiant Panel Heater* which combines warm air circulation with radiant heat. A "ruffled" porcelain enamel front has been designed to increase the radiating capacity. The heat exchanger is separated from the wall and cabinet front by multiple air spaces for increased efficiency and safety.

The Bryant heater is 5½ in. thick, and is said to require a minimum of floor space. It is available in ratings of 15,000, 20,000 and 25,000 Btu input.

(Continued on page 198)

For Tailored Beauty  
Specify  
Concealed, Compact

## RIXSON UNI-CHECK Door Control

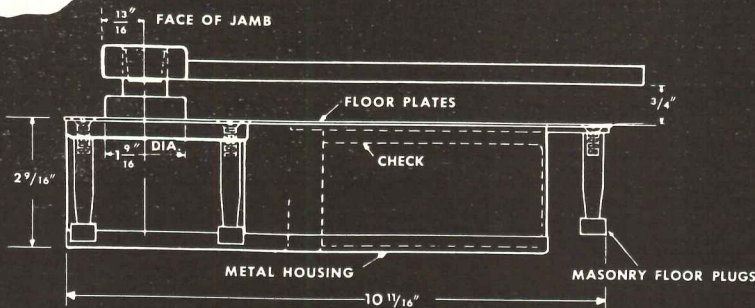

For Any Interior Door—at a  
Cost Comparable to Ordinary Treatment

Wherever self-closing doors are convenient or necessary, the Rixson Uni-Check is chosen by many hundreds of architects and builders for its clean-cut, functional design and quiet, automatic operation.

In four spring capacities, the Uni-Check is suited to any interior door, wood or metal—permanent partitions as well as main doors.

Note the compact width and depth of this sturdy unit. Only six movable parts. The door is mounted directly on the Uni-Check. The top pivot is offered in cast bronze or malleable iron or with ball bearing. Automatic hold-open device available.

For a concealed interior door control anywhere, consider the Uni-Check.

Special problems of installation will receive prompt attention from the Rixson engineering and designing departments.

**The Oscar C. Rixson Company**

4450 Carroll Avenue, Chicago 24, Illinois • Telephone MAAnsfield 6-5050

ESTABLISHED 1900

Sales Representatives in Principal Cities





Architect: Rosario Candela, New York. Engineer: Louis d'Antona, New York. Steel Fabricator and Erector: Schacht Steel Construction, Inc., New York.

# Designed for Good Living

Close to the Henry Hudson Parkway in uptown New York's Riverdale section stands this magnificent new apartment, Riverdale Towers. Faced with red brick, and with its spacious, well-planned rooms tastefully decorated, the structure has facilities for 240 families, in units of 3½, 4½ and 5 rooms. It is 11 stories high, and includes a penthouse and garage.

Riverdale Towers takes its place in the ranks of impressive structures having steel sinews of Bethlehem Structural Shapes.

**BETHLEHEM STEEL COMPANY, BETHLEHEM, PA.**

*On the Pacific Coast Bethlehem products are sold by  
Bethlehem Pacific Coast Steel Corporation  
Export Distributor: Bethlehem Steel Export Corporation*

*Bethlehem*  
**STRUCTURAL  
SHAPES**



(Continued from page 196)

The small sizes burn all gases; the larger size burns natural, manufactured and mixed gases only. All models have enameled finish. Bryant Heater Div., Affiliated Gas Equipment, Inc., 17825 St. Clair Ave., Cleveland 10, Ohio.

### PORTABLE PIPE BENDER

Now in production is a portable, hydraulic pipe bender designed to handle extra heavy pipe or rigid conduit from

$\frac{3}{8}$  to 4 in. Semicircular bending formers and an indicator showing the degree of bend are claimed to make the machine fool-proof. Only 15 minutes are required to make 90 degree bends in 4 in. pipe, according to the manufacturer. Change-over from one pipe size to another is said to take only a few seconds. The bender can be set up easily for on-the-spot installation and repair. Tal Bender, Inc., 417 N. Water, Milwaukee, Wis.

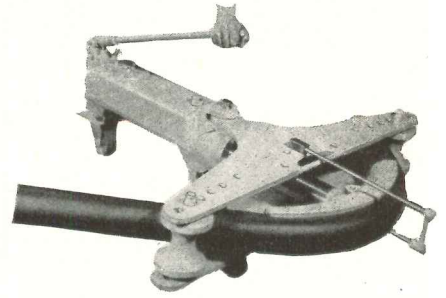

Portable bender takes pipe up to 4 in.

### EXTERIOR SLIDING DOOR WEATHER STRIPS

A new line of extruded metal weather strips and saddles has recently been developed to meet the increasing applications of exterior sliding doors and glass walls. The bronze saddles and weather stripping are designed to make possible smooth, efficient operation while providing dependable weatherproof qualities and reducing air infiltration.

The doors can be used either with overhead hangers, or they can slide on concealed bronze sheaves rolling on rigid, extruded, weather-tight bronze floor track. Use of the sheaves is recom-

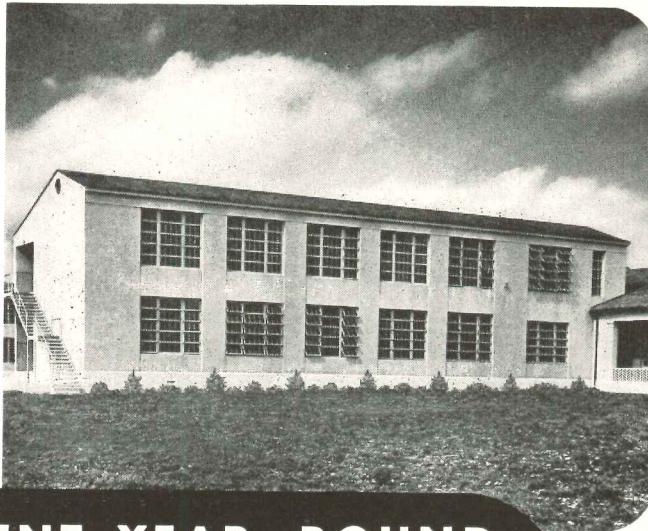

MELROSE SCHOOL  
MIAMI, FLORIDA

August Geiger,  
Architect

"Air conditioned"  
by nature and  
Gate City  
Awning Windows

## EFFICIENT YEAR-ROUND CLASSROOM VENTILATION at Ordinary Window Cost

• Minds stay alert when classroom air is fresh and circulating. By specifying Gate City Awning Windows, you can provide maximum ventilation plus scientific control at extremely moderate cost.

Hinged at the top to extend outward, the sash intercept the outdoor currents of air. Deflected indoors, these currents agitate the air mass at the ceiling . . . prevent the room from becoming stuffy. In addition, Gate City Awning Windows also offer complete glare and heat control by providing positive mechanically con-

trolled positions with various types of glass. Rigidly constructed of wood, Gate City Awning Windows cannot rattle, flutter or squeak. Their operating handle may be detached to prevent tampering. Their design discourages any desire to lean out.

Despite these important advantages, Gate City Awning Windows compare favorably in cost with conventional windows. They deserve careful consideration for any school or church.

For further information, write Gate City Sash & Door Co., Dept. R-6, Fort Lauderdale, Fla., or see Sweet's.



AWNING WINDOWS BY  
**Gate City**

Offices and Factory: Fort Lauderdale, Florida • Export Sales Representative: Frazar & Company, 50 Church Street, New York 7, U.S.A. • Cable Address: Frazar, N. Y. • Agents in principal cities throughout the world.

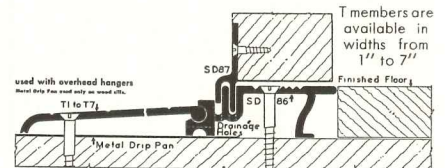

Extruded metal saddles provide weatherproofing for exterior sliding doors

mended by the manufacturer since this simplifies the problems of both construction and weather stripping.

Saddles are available in raised, semi-flush or flush types. The flush type saddle (flush with both inside and outside floors) was developed to accommodate the rolling of chairs, beds, etc. from a room to a covered porch.

Accurate Metal Weather Strips are available in a number of types to meet the peculiarities of particular door constructions. Accurate Metal Weather Strip Co., Inc., 215 E. 26th St., New York 10, N. Y.

### LAVATORIES WITH FOOT PEDAL FLOW CONTROL

Two new models in the Crane line of vitreous china lavatories utilize a foot pedal control for regulating the flow of water, thus providing water-saving and convenience advantages. These lava-

(Continued on page 200)

**WHY A WELL PLANNED LIGHTING INSTALLATION  
NEEDS CORNING**

**ALBA-LITE**

Well planned fluorescent lighting results not only from the design and location of fixtures but also from the proper use of lighting glassware. Corning ALBA-LITE deserves special recognition for its qualities of diffusion and brightness control.

It diffusely transmits 60 to 65% of the light and diffusely reflects 25 to 35%, making its efficiency greater than 90% (the sum of reflection and transmission). This combined with even transmission and low panel brightness makes it adaptable to almost any type of fluorescent installation.

All these qualities are contained in a thin glass panel which permits shallow fixture construction, whether in fixtures or in complete ceilings. Cleaned easily, ALBA-LITE does not retain finger prints and resists weathering. It will not warp, discolor or scratch, regardless of the length of time in use. Add this to sound lighting qualities and you get efficient lighting performance.

Bulletin LS-17, now available, describes how ALBA-LITE is used for direct, semi-direct, semi-indirect lighting and completely luminous ceilings. It also covers Corning's complete line of Engineered Lightingware. You should have a copy if lighting is one of your responsibilities.

**ALBA-LITE** is used on almost every floor of the Esso Building, New York City; Architects: Carson & Lundin; Lighting Engineers: Pollak & Grieve; Fixture Manufacturer: Caldwell & Co., all of New York City.

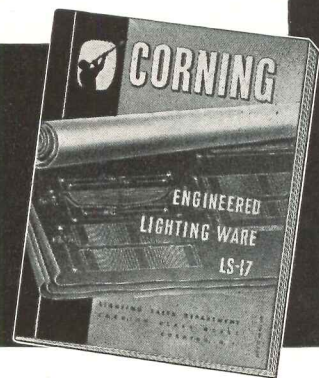
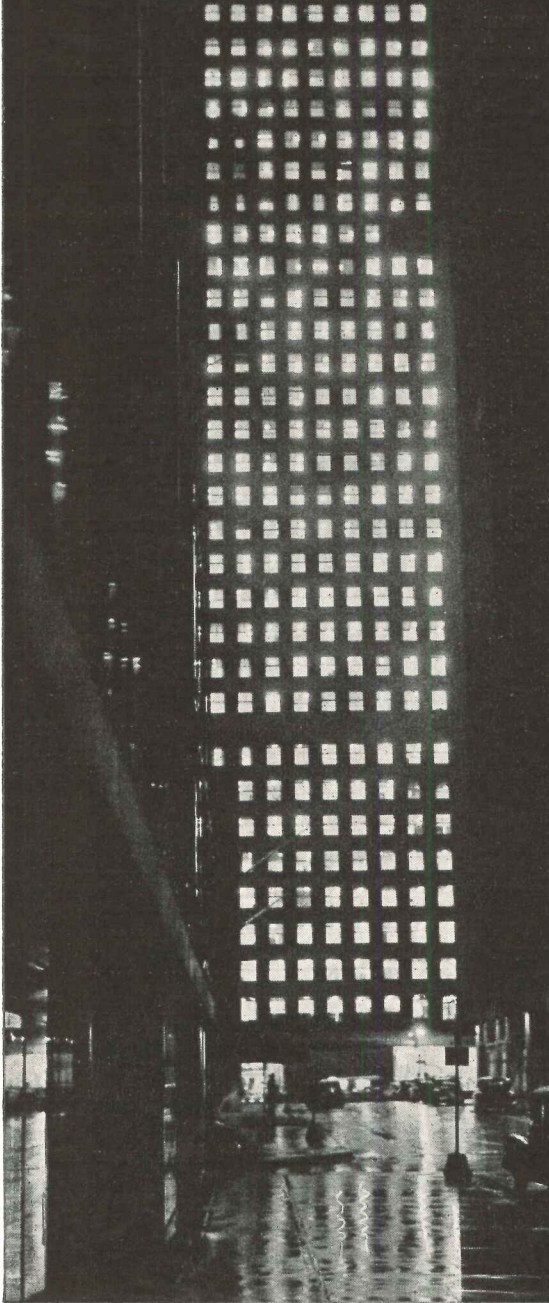

**CORNING GLASS WORKS, DEPT. AR6, CORNING, N. Y.**

Please send me your Data Book LS-17, "Corning Engineered Lightingware," describing MONA-LITE, ALBA-LITE and other Corning products.

NAME \_\_\_\_\_ TITLE \_\_\_\_\_  
 COMPANY \_\_\_\_\_  
 ADDRESS \_\_\_\_\_  
 CITY \_\_\_\_\_ ZONE \_\_\_\_\_ STATE \_\_\_\_\_

(Continued from page 198)

tories are especially applicable for use in industrial, commercial and institutional buildings where it is important that water be automatically turned off when not in use.

A hand valve mounted on the top shelf of the lavatory makes it possible for the user to adjust the temperature of the running water.

Water is supplied through a single spout which is equipped with a spray fit-

ting to prevent splashing. A pop-up plug, with operating handle at the back of the spout is included so that the basin may be filled if desired.

The *Lavalux*, 18 by 15 in., is a flat-back unit for wall mounting. The *Sanicor*, 17 by 17 in. overall, is a space-saving corner lavatory. Both are available in white or in a variety of colors. Crane Co., 836 S. Michigan Ave., Chicago 5, Ill.

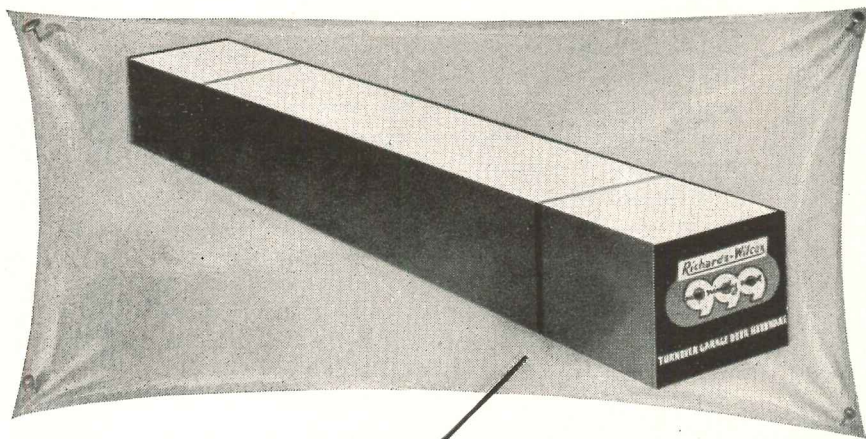

## Best Seller this Summer

### NEW RICHARDS-WILCOX 999 GARAGE DOOR HARDWARE

Get started now! Check your garage door prospects and start selling them the advantages of converting out-dated swinging doors to modern overhead doors with Richards-Wilcox Garage Door Hardware. Comes complete. Packed in one convenient carton. Easy to handle. Includes all hardware needed for installation and operation. Can be easily and quickly installed by the customer.

Backed by over 69 years of experience and engineering skill in the design and manufacture of all kinds of door hardware, Richards-Wilcox 999 Garage Door Hardware is one of your best bets for a profitable summer. For further information, please telephone, write or wire our nearest office, today.

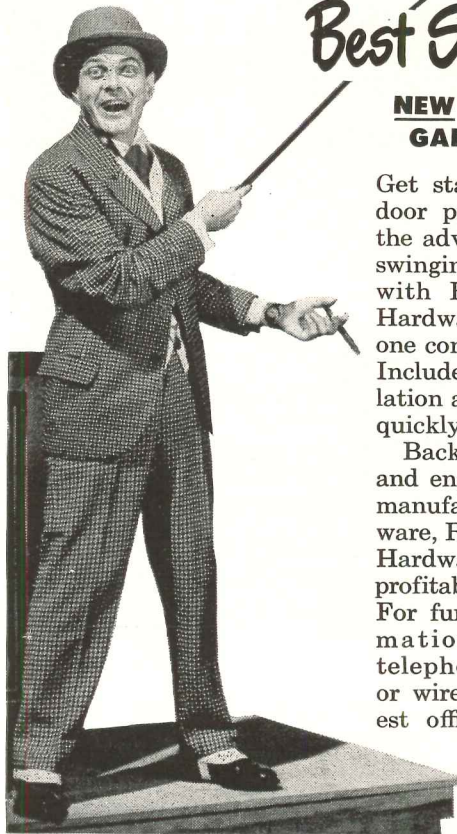
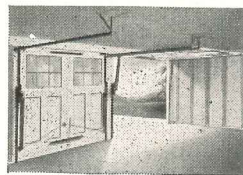

## Richards-Wilcox Mfg. Co.

"A HANGER FOR ANY DOOR THAT SLIDES"  
AURORA, ILLINOIS, U.S.A.

Branches: New York Chicago Boston Philadelphia Cleveland Cincinnati Washington, D.C.  
Indianapolis St. Louis New Orleans Des Moines Minneapolis Kansas City  
Los Angeles San Francisco Denver Seattle Detroit Atlanta Pittsburgh

1880 1949



OVER 69 YEARS

### FLUORESCENT LUMINAIRES

Designed to combine maximum lumen output and minimum brightness ratios with economy and ease of installation, the *Monroe* fluorescent luminaires give both downward and upward light distribution and have 35° cross-wise and 25° lengthwise shielding.

The units, which are available in three models, have one-piece, removable louver-assemblies that allow easy access to wiring channels for installing. They may be ceiling or pendant mounted individually or in continuous rows.

The luminaires, available with aluminum side panel, plastic side panel, or in all steel, are 48 in. long, 12½ in. wide and 5 in. deep. Pittsburgh Reflector Co., 402 Oliver Bldg., Pittsburgh 2, Pa.

### ROOF CONSTRUCTION AID

An inexpensive new instrument made of Vinylite rigid plastic has been devised for quick and accurate calculation of lengths and cuts of all roof rafters.

Exact readings for lengths and angles of the various kinds of rafters required are produced at arrows on the diagram face of the instrument by merely setting two dials.

The instrument is said to make it possible also to design a roof with any pitch from 14 degrees to 57 degrees as well as the standard pitches and converting angles in degrees for marking on the carpenter's square.

The instrument is less than ¼ in. thick, measures 6¼ by 8¼ in. and weighs less than 2 oz. Edward Weyer, 40 W. 77th St., New York 24, N. Y.

### GLASS BLOCK FOR CLASSROOMS

Designed especially for school classrooms in those parts of the country which have the greatest sunlight, is a new type of prismatic glass block. Known as *Insulux Glass Block No. 352*, it is said to make possible lower brightness contrasts than any other fenestration material now available. The manufacturer reports that the new block is particularly effective in the brightest sun exposures, and is recommended for schools and other public buildings in such states as California, Texas and Arizona. American Structural Products Co., Toledo 1, Ohio.

### COUNTER-TOP LAVATORIES

Two new lavatories for use in bathrooms, powder rooms and bedrooms are especially designed to fit into counter tops, whether they are tile, linoleum,

(Continued on page 202)



# Steel pipe is first choice

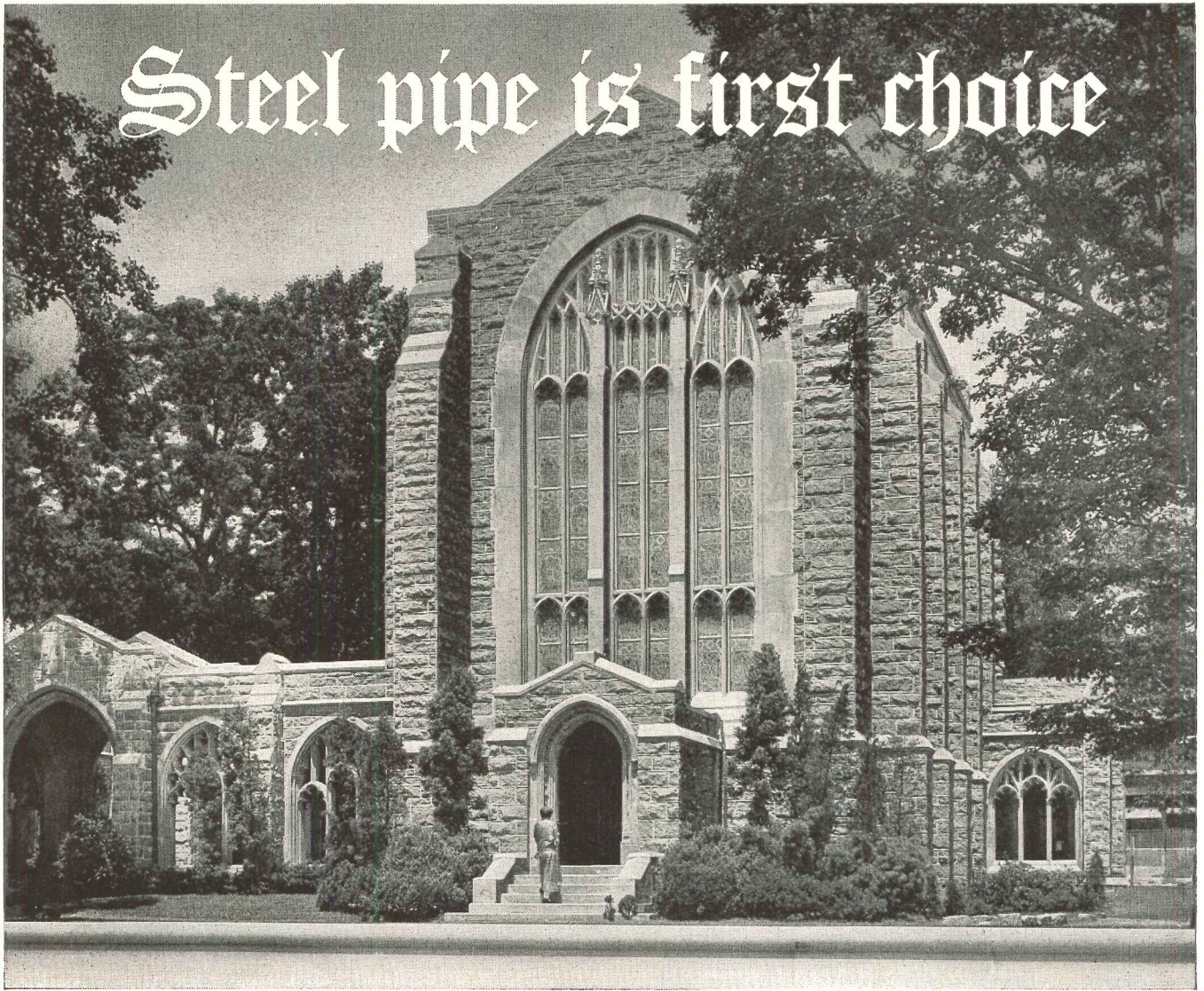

## *for the churches of America*

There are 253,762 churches in continental United States with nearly 74 million members. Their presence in every city and town, and in hamlet and countryside across the nation, is a tribute to the essential morality of Americans.

Into these temples of worship we have poured the richness of the architectural inspiration of the past and present, so that today the white spire of a country church or the majesty of a gothic cathedral represents the finest creative efforts of the men who build.

Beyond the structural elements of steel and concrete, brick and stone, attainment approaching perfection has been assured by today's high standards

of materials. Not the least of these is *steel pipe*, helping to make each church a comfortable place in which to worship, through adequate heating, plumbing, lighting, and ventilation. For these services *steel pipe* has a dominant place because *steel pipe* is durable, adaptable, serviceable, and economical.

In fact, of all pipe used for plumbing and heating purposes in all types of structures, steel pipe predominates by a wide margin. Yes, *steel pipe is first choice!*

---

*Ask for your copy of the interesting story "Pipe in American Life."*

**COMMITTEE ON STEEL PIPE RESEARCH OF AMERICAN IRON AND STEEL INSTITUTE**

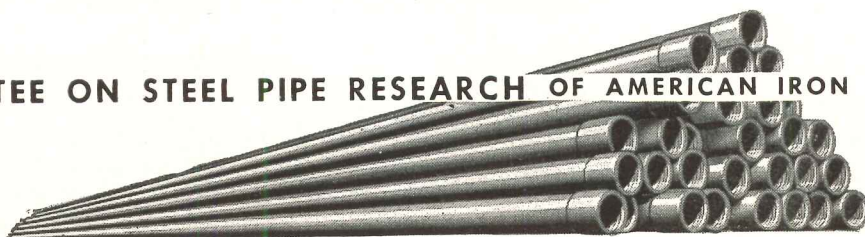

350 Fifth Avenue  
New York 7, N. Y.

glass, formica, wood, or other materials.

Both the *Marcia* and the *Elayne* have semi-oval basins of vitreous china (available in colors as well as white) and chromium-plated brass controls, and both have positive lever-action waste control.

The *Marcia*, which has a raised angle panel to place the controls in a convenient position, measures 24 by 21 in. overall; the *Elayne*, with chrome-plated

handles and spout mounted on slightly raised portions at the back, measures 27 by 20 in. overall.

These lavatories are especially recommended for a powder room or for use in a bedroom, perhaps as part of a built-in dressing table, to help cut down morning bathroom conflict and as a convenience in the event of illness. Crane Co., 836 S. Michigan Ave., Chicago 5, Ill.

(Continued from page 200)

## STEEL-WOOD LOCKERS

A new line of *Steel-Wood* lockers makes use of both steel and Masonite: the lockers have steel framework and doors; all other parts are steel reinforced Masonite. Steel parts are finished in green enamel, and the Masonite is its natural brown color. They are made in both single and double tiers in all standard sizes.

Recessed handles feature satin chrome finish, and are designed to accommodate number plates. Lyon Metal Products, Inc., Aurora, Ill.

## DISINFECTANT CEMENT

Patents have been reported obtained by the North American Cement Corp. for a disinfectant hydraulic cement. While bacteria are claimed killed on contact, the concrete is said to be non-toxic to animals or humans. The product is described as being mixed in the same way as Portland cement and as having the same physical attributes. North American Cement Corp., 41 E. 42nd St., New York 17, N. Y.

## SANITIZED DRYERS

*Hamilton Automatic Clothes Dryers* are now equipped with an ultra-violet light, *Sun-E-Day Lamp*, which is reported to sanitize clothes as they dry. In addition to germ-killing radiation, the lamp gives off a second type of ultra-violet radiation which is said to freshen clothes and prevent staleness in the dryer when not in use. The lamp is shielded to direct all radiation into the dryer and to prevent exposure to the operator's eyes. Hamilton Mfg. Co., Home Appliance Division, Two Rivers, Wis.

## ADJUSTABLE SPOTLIGHT

*Adjust-O-Spot*, a new adjustable spotlight which has Underwriters' Laboratories approval, is small and compact, rotates 360° in any direction, and tilts to 27° on the vertical.

Completely wired and supplied with plaster frame, the spotlight takes either an R-40 or a PAR-38 lamp.

*Adjust-O-Spot* comes in brushed satin chrome finish or in colors. Louver and heat-resisting glass color filters are available. Litecraft Mfg. Co., 135 Rome St., Newark, N. J.

## DISHWASHER-DISPOSAL UNIT

The *Timesaver Sink* combines a water-powered dishwasher and a disposal unit in a 48-in. wide steel cabinet. It is equipped with a porcelain work surface,

(Continued on page 204)

## ANOTHER MODERN SCHOOL

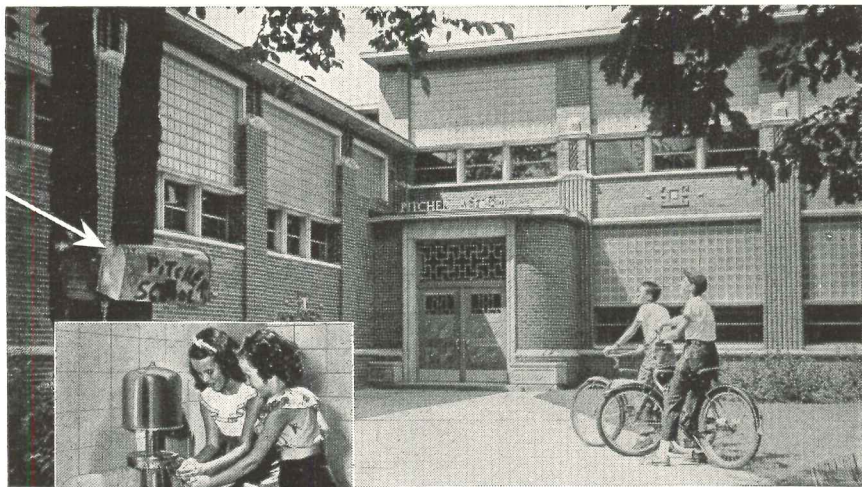

George D. Mason & Co. Architects. Farrell & White, Engineers.

## INSTALLS BRADLEY WASHFOUNTAINS

Pitcher School, Detroit, Michigan. Bradley Wall-Type Washfountain Installation.

Sanitary Bradley Washfountains are used in all kinds of schools—public, pa-

rochial, and private; from kindergartens to colleges; in washrooms, classrooms, shops and cafeterias.

Bradleys provide the finest in health protection with automatic FOOT-CONTROL, self-flushing bowl and easy-to-clean sprayhead. Each student is provided with an individual ever-clean spray of pure running water and hands are kept free from contagious faucet or washbasin contacts.

Bradley Washfountains come in 54" and 36" circular models serving 10 and 6 students respectively and in two sizes of semi-circular models for 3 or 5 students. Illustrated Catalog 4701 gives full information on the complete Bradley line.

Write for your copy to BRADLEY WASHFOUNTAIN CO., 2227 W. Michigan Street, Milwaukee 1, Wisconsin.

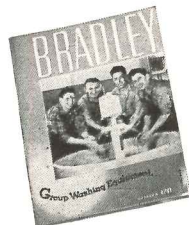

Distributed Through  
Plumbing Wholesalers.

**BRADLEY**  
washfountains

**EASY TO SPECIFY—**

**EASY TO INSTALL**

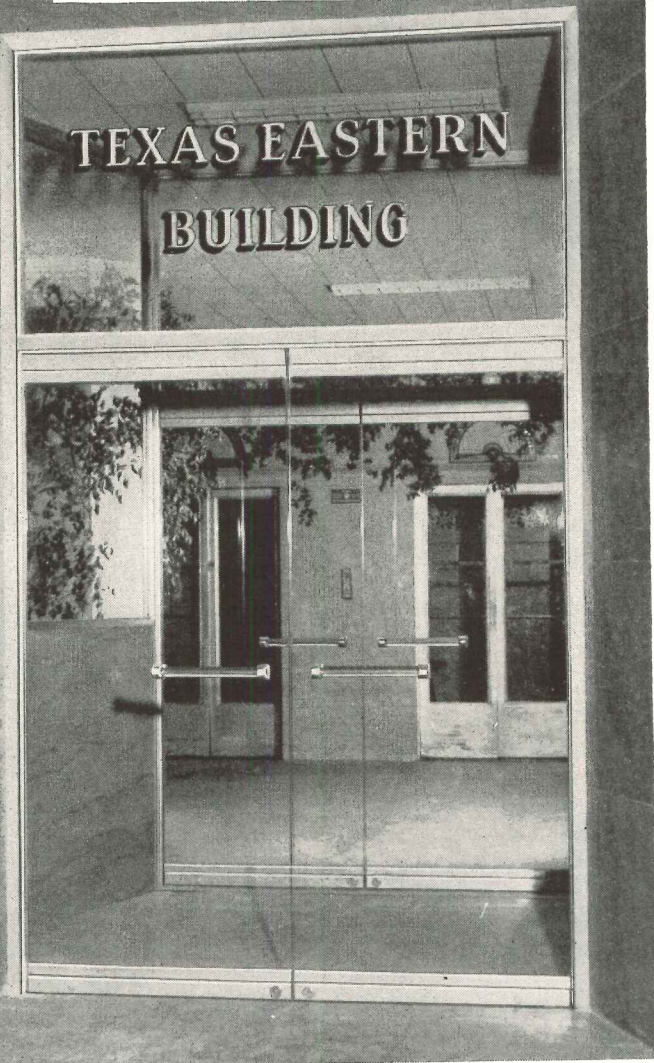

Architects: Neild & Somdal, Shreveport, La.

... that's why architects favor  
"Pittsburgh's" factory-assembled  
door-frame

UNTIRING research into ways and means of helping to solve architectural problems actually encountered in the field was responsible for the creation of this revolutionary prefabricated door-frame assembly. Its ease of specification and installation—as well as its uniform excellence of performance in service—appeal to every architect. All you do is indicate the name—"Herculite Door-Frame Assembly"—and provide the style number and size. It reaches the job completely assembled and with everything needed for its immediate installation, including the famous Pittco Checking Floor Hinge, moldings for transom glass, supports for sidelights, strikes for locks, sockets for bolts.

"Pittsburgh's" Herculite Door-Frame Assembly is a handsome, simply designed and sturdily constructed unit. The frame is factory-built of special shapes and of heavy extruded aluminum, heavily reinforced with structural steel. It's built to high quality standards by expert craftsmen who use special checking gauges to make sure that all dimensions are absolutely accurate.

There's much more to the story. So why not fill in and return the coupon for our interesting and informative booklet? It's free and you're under no obligation. Do it now.

# HERCULITE DOOR-FRAME ASSEMBLY

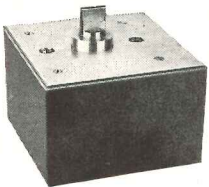

◀ This Pittco Checking Floor Hinge is an engineering triumph. Only 6¼" x 6¼", it provides positive door speed control, separate checking control, built-in hold-open feature. It's sealed in oil for life. Case and cover are drop-forged. Main working parts are hardened and ground tool steel. Bearings are anti-friction precision-ground.

Handsome, rugged construction is indicated by this sectional view. Note extra-heavy extruded aluminum, highly polished and anodized; also steel channel and tie rod reinforcement. ▶

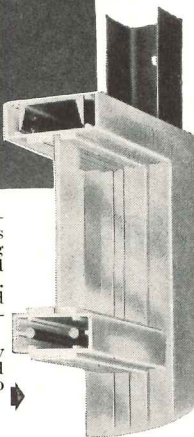

Pittsburgh Plate Glass Company  
2158-9 Grant Building, Pittsburgh 19, Pa.  
Without obligation on my part, please send me a FREE copy of your booklet on "Pittsburgh's" factory-built Herculite Door-Frame Assembly.

Name.....  
Address.....  
City..... State.....



PAINTS · GLASS · CHEMICALS · BRUSHES · PLASTICS

**PITTSBURGH PLATE GLASS COMPANY**

(Continued from page 202)

four access doors, full base shelf, mixer faucet and spray attachment. The new sink-combination has been designed for easy installation, requiring minimum connections, either in new construction or as a modernization unit in existing homes.

Timesaver Sink is 48 in. wide, 36 in. high to work surface, and 25 in. deep, and has a 4-in splashboard. The top assembly, of porcelainized steel, contains a sink 19 1/4 in. long, 16 1/4 in. wide and 8 in. deep. The dishwasher, mounted on the right-hand side of the cabinet, is fitted with a porcelainized steel lid which is set flush with the working surface to provide maximum counter space when the lid is closed. The white baked-enamel cabinet has a black recessed base. Kaiser Fleetwings Sales Corp., Kaiser Bldg., 1924 Broadway, Oakland 12, Calif.

**COOLING TOWER**

Greater simplification in design, compactness and versatility are advantages claimed for the *Acme Induced Draft Cooling Tower*. These are apparent from such features as: (1) fan housing adjustable on the job for either horizontal or vertical discharge; (2) manifold connections on all four sides; (3) 5-ton unit occupies space of only 35 by 35 by 69 in. Other features include a centrifugal fan which permits long runs and the travel of air and water in counter flow. The cooling tower is available in 5-, 10-, 15-, and 20-ton sizes. Acme Equipment Co., 213 E. Broadway, Muskogee, Okla.

**STANDARDS**

*Commercial Standard for Douglas Fir Plywood (CS45-48)*. Covers the four basic standard grades of veneer, "A", "B", "C" and "D". Plywood grades as made up from these veneers are covered by simplified tables. This revised edition takes up detail requirements for six grades of Exterior type, and seven grades of Interior type plywood. Two new grades have been added in both Interior and Exterior types, made possible by the introduction of the B quality veneer which has a solid surface. Bondage requirements have been made more severe for the Exterior type. Superintendent of Documents, Government Printing Office, Washington 25, D. C. 10 cents.

achieve  
distinctive  
interiors  
at  
less  
expense  
to your  
client

**STAIN AND WAX** interior  
woodwork in one application  
... save time ... save expen-  
sive labor costs! Cabot's  
Stain Wax penetrates deeply  
... sets up quickly ... gives  
plywood paneling and all  
interior woodwork an easily-  
cleaned, lustrous wax finish!  
Your clients may choose  
from a wide range of attrac-  
tive colors, including such  
light shades as Ivory, Silver  
Gray and White.

Write for color card and  
complete information today!

SAMUEL CABOT, INC.  
622 OLIVER BUILDING  
BOSTON 9, MASS.

**CABOT'S  
STAIN WAX**

**NEW — FASTER-DRYING**  
*Sani-Dri*

**ELIMINATES  
TOWEL  
INCONVENIENCE  
FOREVER!**

Modernizes without  
Structural Changes.  
Approved by Under-  
writer's Laboratories  
for 18 years!

**DRYS HANDS OR FACE  
25% FASTER  
THAN EVER BEFORE**

Now you can provide 24-hour hand or face drying service in your washrooms, and eliminate your towel problem completely! The new, faster-drying Sani-Dri dries quickly and thoroughly with a stream of hot air, the most sanitary method known. A new heating element and faster-flow nozzle makes it the fastest drying machine of its kind ... 25% faster than before! Sani-Driers are ideal for modernization of old washrooms or new installations. They have been installed and used in every civilized country and in every climatic condition. They have stood the test of time for 22 years!

**SAVES 85% OF WASHROOM COSTS**

Sani-Dri pays for itself out of savings. No buying or stocking of towels. No unsanitary litter ... no fire hazard ... no paper-clogged soil pipes ... no servicing of empty towel cabinets —Sani-Dri gives years of continuous automatic drying service with little or no maintenance! Mail coupon for complete information.

**USERS REPORT:**

"22 Years of  
Continuous  
Drying Service"  
"Our 60 Sani-Driers  
have been in continuous  
use since we installed  
them in 1927 and are  
still giving excellent  
service. We figure they  
paid for themselves in  
less than two years,  
and have made our  
washrooms neater and  
more sanitary at a very  
low cost."  
(Names of Users Sent  
Upon Request)

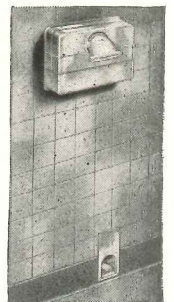

Built-in wall model for  
new installations.

Distributors in Principal Cities

**GET THE LATEST FACTS!**  
New brochure 1082 shows both  
built-in wall and pedestal mod-  
els of new faster-drying Sani-  
Dri electric hand and face  
dryer. Write today!  
Distributors in Principal Cities

**THE CHICAGO HARDWARE FOUNDRY CO.**  
"Dependable Since 1897"  
8649 Commonwealth Avenue  
NORTH CHICAGO, ILL.

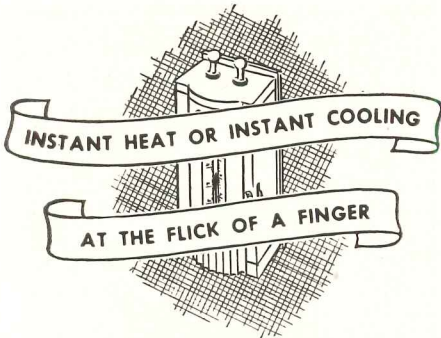

# Servel *All-Year*

## Air Conditioning provides

**INSTANT COOLING OR INSTANT HEAT**

**FREEDOM FROM DUST AND DIRT**

**FOR YOUR CLIENTS' HOMES OR OFFICES**

The homes and business structures you design can have added comfort by building your plans around the amazingly different Servel *All-Year* Air Conditioner.

Servel is different because it not only provides refreshing, refrigerated, dehumidified cooling in summer—it also provides draft-free heating in winter. With this one compact unit, your clients enjoy year-round comfort, ideal indoor climate. With a mere flick of a switch, Servel can be changed from heating to cooling in the same day if desired. And relative humidity is always just right.

The Servel unit is economical to operate; it is backed by a 5-year warranty; it enables you to effect many design and construction economies. For complete facts on Servel *All-Year* Air Conditioning, ask your local Gas Company, or write direct to Servel, Inc., 8906 Morton Avenue, Evansville 20, Indiana.

### ONLY SERVEL OFFERS ALL THESE ADVANTAGES

- Draft-free warmth
- Efficient cooling
- Positive dehumidification
- Fingertip control
- Dependable performance
- Filter-cleaned air
- Economical operation
- 5-year warranty
- No moving parts in cooling system

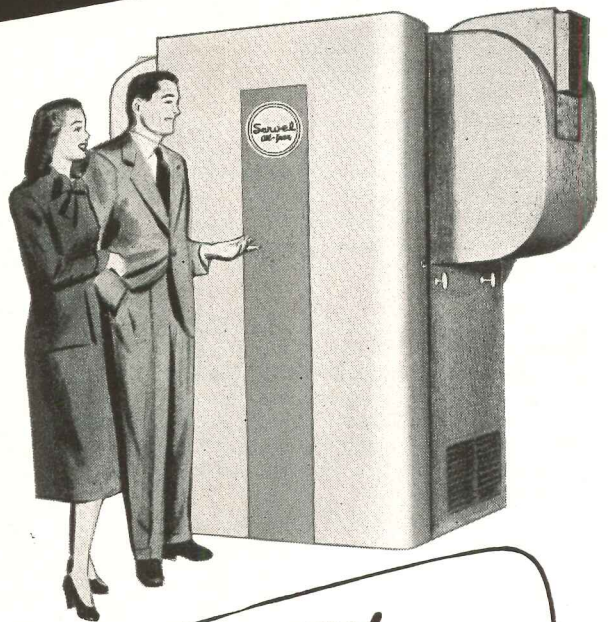

**SERVEL *All-Year*  
AIR CONDITIONER**

Only **ANCHOR FENCE**  
gives you

- ✓ **DEEP-DRIVEN ANCHORS**
- ✓ **SQUARE FRAME GATES**
- ✓ **H-BEAM LINE POSTS**
- ✓ **SQUARE TERMINAL POSTS**

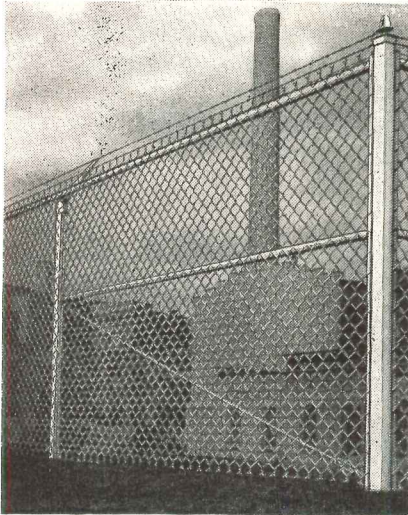

Specify **ANCHOR** and  
be **SAFE!**

**WHETHER** you're specifying fence for industrial, institutional or residential jobs, you can rely on Anchor Chain Link Fence to insure lasting fence protection for your clients. For years, leading architects have been writing "Anchor" into their fence specs for features like these:

1. *Deep-Driven Anchors*, which hold the fence erect and in line, in any soil or weather; 2. *Square Frame Gates*, amazingly free from warping and sagging; 3. *H-Beam Line Posts*, self-draining, rust-free and rigid; 4. *Square Terminal Posts*, which improve strength, durability and appearance.

Make sure your A.I.A. File 14-K is complete. Write today for our free, illustrated booklet . . . showing many types and uses of Anchor Chain Link Fence . . . containing structural diagrams and specifications.

Write for your copy to: **ANCHOR POST FENCE DIVISION**, Anchor Post Products, Inc., 6600 Eastern Avenue, Baltimore 24, Maryland.

**Anchor Fence**

Nationwide Sales and Erecting Service

(Continued from page 154)

up the importance of painting putty, under what conditions putty can be applied in winter, etc. 10 pp., illus. The Dicks-Pontius Co., Dayton, Ohio.

**Glass Block**

*Adding Value to Apartment Buildings.* Illustrates and explains decorative as well as functional uses of glass block in apartments. Contains suggested installations such as in entrances, dining rooms, living rooms, kitchens and bathrooms. Remodeling suggestions are included. 4 pp., illus. American Structural Products Co., Sales Promotion Dept., Toledo 1, Ohio.

**Soda Fountain Equipment**

*Stanley Knight Soda Fountain and Luncheonette Equipment.* Describes new line of soda fountains, creamer units, sandwich units, toaster sections, hot food units, shelving and service tables, storage units, back bar equipment, counters and carbonators. New features are illustrated with cutaway drawings. 24 pp., illus. Stanley Knight Corp., 3430 N. Pulaski Rd., Chicago 41, Ill.

**Lavatories, Dressing Tables**

*What's New in the Bathroom.* Shows different ideas in using *Formica* in the construction of lavatories and dressing tables, ranging from deluxe designs for hotels to those for low budget homes. A sheet of suggested construction details is included. 5 pp., illus. Formica Co., c/o F. C. Walter, 4941 Spring Grove Ave., Cincinnati 32, Ohio.\*

**Heating Equipment**

*A Million Dollar Heating Idea That's Yours for the Asking.* Outlines the operating principles and advantages of a heating system for basementless houses which provides perimeter heating of the floor plus forced warm air heating of the occupied space. The system is designed for operation on either oil or gas. 4 pp., illus. International Oil Burner Co., Spring and Park Avenues, St. Louis 10, Mo.

(1) *Unit Heaters* (Bulletin No. 638A); (2) *Heating Appliances* (Bulletin No. 634B). The first bulletin covers the appearance, construction and performance of unit heaters made by Dunham. The second describes three types of unit

(Continued on page 208)

*Slash  
Power  
Costs!!*

SPECIFY

**FUEL OIL**

AND

**TODD  
BURNERS**

**FOR YOUR  
BOILER PLANT!**

You'll be amazed how Todd Burners cut your fuel and maintenance costs. Savings up to 10% . . . increased power capacity can be yours with Todd Burners. In replacement of obsolete equipment or in new installations, skilled specialists—backed by 35 years of Todd experience—engineer your job individually to assure you utmost economy in burning of liquid or gaseous fuels.

Oil Burners

Gas Burners

Combination

Oil and Gas  
Burners

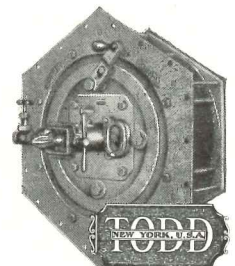

**COMBUSTION EQUIPMENT DIVISION**

**TODD SHIPYARDS CORPORATION**

81-16 45th Ave., Elmhurst, Queens, N. Y.

NEW YORK • BROOKLYN • ROCHESTER  
BUFFALO • HOBOKEN • NEWARK • PHILADELPHIA  
HARRISBURG • YORK • CHICAGO • CHARLESTON,  
S. C. • BOSTON • SPRINGFIELD, MASS.  
BALTIMORE • WASHINGTON • RICHMOND, VA.  
ATLANTA • DETROIT • GRAND RAPIDS • TAMPA  
GALVESTON • HOUSTON • MOBILE • NEW  
ORLEANS • LOS ANGELES • SAN FRANCISCO  
SEATTLE • MONTREAL • TORONTO  
BARRANQUILLA • BUENOS AIRES • LONDON



**Compare this Metal Door for Appearance . . . for Quality**  
*then look at the price!*

Handsomely-styled Fenestra\* Standard Stock Metal Doors are designed for the finest buildings. They look expensive. But they're not.

One reason for their low cost is Fenestra standardization. Standardization streamlines production . . . keeps quality uniformly high . . . cost surprisingly low.

You make important savings on installation, too. Insulated Fenestra Metal Doors come complete with frames and hardware.

Installation consists of just 4 simple steps. Bolt the frame together . . . attach the frame to floor and anchor it to walls . . . screw on template locks and hinges . . . hang the door. No mortising, no drilling,

no tapping, no prime painting. Time saved. Trouble saved. Money saved.

**COMPLETE FENESTRA DOORS ARE AVAILABLE IMMEDIATELY**

Fenestra Doors, including those with the Underwriters' B Label, are immediately available from conveniently located stocks. The complete unit—door, frame and hardware—comes carefully wrapped to protect the finish.

For further information, call your local Fenestra Representative (see phone book listing), see Sweet's Architectural File, Section 15a/7, or write Detroit Steel Products Company, Dept. AR-6, 2252 East Grand Boulevard, Detroit 11, Michigan.

\*Trademark

*Fenestra* **STANDARD STOCK METAL SWING AND SLIDE DOORS**

# PROTECT LIVES AND PROFITS! SPECIFY...



MODEL 10EL  
10,000 WATTS

**Onan Emergency Electric Plants provide power for all essential needs . . .**

LIGHTS • REFRIGERATION • VENTILATING SYSTEMS • COMMUNICATIONS • OIL BURNERS • STOKERS • ELEVATORS

\* When storms, floods or breakdowns interrupt commercial power, Onan Standby Plants start automatically and take over the power load within seconds, stop when power is restored. Operating and maintenance costs are negligible. Widely used in hospitals and other institutions, radio stations, hatcheries, theaters, industrial plants . . . wherever power interruptions would be dangerous and costly. Available from 1000 to 35,000 watts.

*What size Standby Plant will your project need?*



Send coupon below for folder on Onan Standby Plants. It will help you specify the right size plant and the necessary accessories. If you have an unusual problem write our engineering department.

**D. W. ONAN & SONS INC.**  
5139 Royalston Ave., Minneapolis 5, Minn.



Please send me your Standby Folder

Name.....  
Address.....  
City.....State.....

**ONAN STANDBY POWER**

(Continued from page 206)

heaters, a full line of cabinet convectors, baseboard convectors, finned radiation, pumps and steam specialties. 14 and 12 pp., illus. C. A. Dunham Co., 400 W. Madison St., Chicago 6, Ill.\*

*Heil Oil-Fired Automatic Heat.* Catalog on a line of automatic furnaces and boilers, including oil and gas fired units as well as gas conversion kits. Operation of the units is described alongside cut-away views of the various models. 12 pp., illus. The Heil Co., 3000 W. Montana St., Milwaukee 1, Wis.\*

(1) *Baseboard Heating Systems* (Guide No. 5); (2) *One Pipe Forced Circulation Hot Water Heating Systems* (Guide No. 100). Guide No. 5 presents a simple and economical basis for selection and installation of baseboard heaters in a one pipe forced circulation hot water system, two pipe forced circulation, gravity hot water, and two pipe steam. Guide No. 100 contains details for calculating and designing one-pipe systems. Institute of Boiler and Radiator Manufacturers, 60 E. 42nd St., New York 17, N. Y. 50 cents each.

### Hand, Face Drier

*Sani-Dri Electric Hand and Face Drier.* Describes a new heating element and a flow nozzle on the Sani-Dri, designed to reduce drying time by 30 per cent. Numerous photos show the drier in typical installations. 8 pp., illus. The Chicago Hardware Foundry Co., North Chicago, Ill.

### Air Filters

*A Comparative Study of Air Filtering Costs in Central Systems.* Contains data on the costs of air filtration along with comparative figures on installation and maintenance costs of cleanable and replacement-type air filters. A form is included for calculating comparative costs of a specific installation. 4 pp., illus. Owens-Corning Fiberglas Corp., Toledo 1, Ohio.\*

### Paint

*How to Beautify and Protect Concrete, Stucco and Masonry.* Describes need and method of painting concrete, stucco and masonry surfaces. Gives advantages of Portland cement paint and cites various

(Continued on page 210)

**New SAFETY RECEPTACLE MAKES CONTACT ONLY WHEN STANDARD CAP IS INSERTED**



**HUBBELL'S SP-49**

The \*SAFETY-PLUS Receptacle

*Actual tests prove it to be Safest Receptacle ever designed*

- Makes contact *ONLY* when standard cap is inserted
- Conventional operation . . . double contact springs
- Back or side wired—shallower for more wire room
- Takes polarized or standard caps

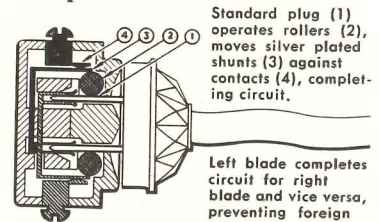

Standard plug (1) operates rollers (2), moves silver plated shunts (3) against contacts (4), completing circuit.

Left blade completes circuit for right blade and vice versa, preventing foreign objects from completing circuit.

Featuring an entirely new principle, the Hubbell SP-49 Receptacle was designed to reduce the possibility of accidental shock and burn, makes contact *ONLY* when standard caps are inserted! Pins, wires or other foreign objects cannot energize the unit! The SP-49 provides easier wiring, more wire room, back wiring, washer ears, silver plated contact springs, interlocking bridge and takes standard caps.



For descriptive literature write

**HARVEY HUBBELL, INC.**

Dept. A-1 Bridgeport 1, Conn.



# WORTHINGTON

## AIR CONDITIONING REPORT

WORTHINGTON PUMP AND MACHINERY CORPORATION  
HARRISON, NEW JERSEY

Specialists in air conditioning  
and refrigeration  
for more than 50 years

### Clinically-clean Air For Children's Hospital

As you can imagine, the air into which a baby is delivered and in which it passes its first few days must be scrupulously clean and its temperature accurately controlled. Too high a room temperature, for example, invites enteritis (inflammation of the intestines), which is common among babies.

In the Children's Hospital, Cincinnati, Worthington equipment is used to air condition the infants' ward, surgical ward and milk preparation room.

The equipment used for the infants' ward includes two Worthington package units, with hermetically-sealed compressors, to cool, dehumidify, clean, circulate and ventilate. Each occupies only eight square feet, but has a cooling capacity of 5 tons.

*No case of enteritis has been reported since the installation was made.*

In the surgical ward, which consists of five operating rooms and five auxiliary work rooms, a Worthington package air conditioner with conven-

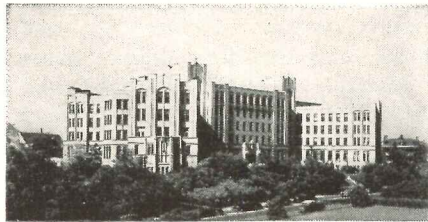

*Children's Hospital, Cincinnati—equipped with Worthington Air Conditioning*

tional reciprocating compressor and evaporative condenser, is used for the comfort and efficiency of surgeons and nurses and, by humidity control, to prevent the hazard of static spark which exists where there are ether fumes.

Another 5-ton package unit with hermetically-sealed compressor provides filtered air to the room where milk formulas are prepared.

Engineering and installation by Henry Niemes, Inc., Cincinnati.

### An Ideal Climate For World-Wide Explorations

Much of the exploration in the oil industry—the geo-physical laboratory type of exploration—is done by Rogers-Ray, Inc., in Houston, Texas, serving petroleum firms all over the world. In line with providing its staff with the best possible working conditions and to maintain constant air conditions in the laboratory, Rogers-Ray has installed Worthington Air Conditioning.

When the instruments are built, it is necessary to maintain tolerances which are so fine that they could be affected by variations in temperature and humidity. In the main offices, it is important to protect against shrinkage or expansion of blueprint and tracing paper carrying finely detailed drawings.

The engineer, H. E. Bovay, Jr., selected Worthington AHY and AVY

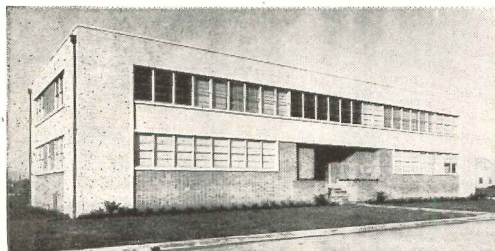

*Office building of Rogers-Ray, Inc., Houston, Texas*

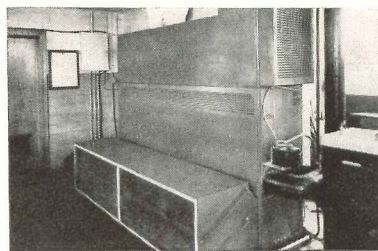

*Worthington AVY Air Conditioning Unit at Rogers-Ray, Inc.*

### Pampering Paper

In the New York plant of General Aniline & Film Corporation's Ozalid Division, makers of white print and dry developing machines and sensitized papers, Worthington Air Conditioning is used to insure constant temperature and humidity conditions for the processing and storage of the film paper.

The equipment includes two horizontal-mounted central station air conditioners and two Freon-12 condensing units.

The compressors are equipped with automatic capacity control, lightweight automotive-type pistons and Worthington Feather\* Valves, lightest, tightest, quietest ever made.

\*U. S. Reg. Pat.

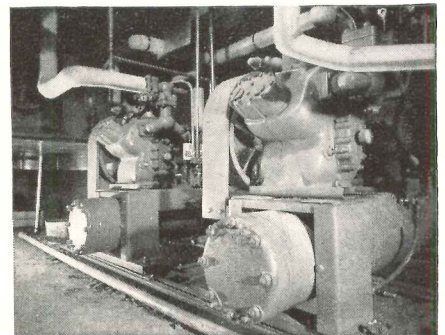

*Worthington Freon-12 Condensing Units at Ozalid plant*

central station air conditioners for complete year-round air conditioning. These units are designed essentially for installation remote from the place to be conditioned. Air distribution is handled in the shop building by one 4500 cfm unit, in the office building by two 4500 cfm units and a 2000 cfm unit. These units are sectionally-constructed, permitting ease of handling, inter-changeability and flexibility of assembly. They are served by two Worthington four-cylinder V-type Freon-12 Compressors, both of which are connected to a single horizontal cleanable-type shell-and-tube condenser.

Installation was made by Gregory-Edwards, Inc. of Houston.

## WORTHINGTON



AIR CONDITIONING AND REFRIGERATION

A complete line . . . in which *all* the vital components are *made*, not just assembled by Worthington. For more worth with Worthington, see your nearby Worthington distributor (consult Classified Telephone Directory).

MASONRY  
JOINTS

Won't  
leak-

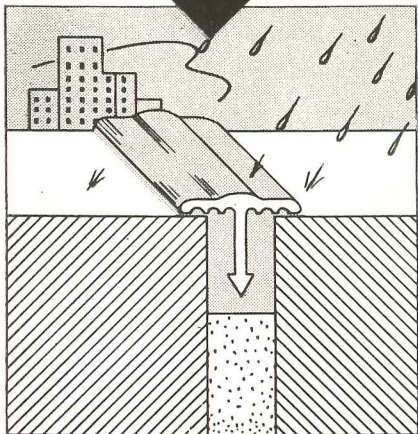

when protected with



WEATHERCAP

• Installed in coping and cornice joints, etc., on either new or old structures, assures years of weather-tight protection.

SEND FOR YOUR SAMPLE

Minwax Company, Inc.  
11 West 42nd St., New York 18, N.Y.

Please send me free sample of Weathercap with descriptive folder and specification data.

Name .....

Address .....

City .....

State .....

AR-6-49

(Continued from page 208)

applications. Discusses a new rubber base coating. 8 pp., illus. Medusa Portland Cement Co., Medusa Products Div., 1000 Midland Bldg., Cleveland 15, Ohio.\*

#### Drainage Products

*Zurn Building, Plumbing, Drainage Products.* Equipment described in this bulletin includes: *cloudburst type* roof drains, *easy level* floor drains, grease interceptors, wall closet fittings and carriers for wall type fixtures. Cut-away views show how Zurn's recently developed floor drains permit quick, easy floor level adjustment without need for resetting. Tables and dimensioned drawings are included. 8 pp., illus. J. A. Zurn Mfg. Co., Dept. Z-7, Erie, Pa.\*

#### Conveyors

*Lamson Products.* Illustrates a complete line of conveyor devices including the following types: roller gravity, live roll, slat, belt, overhead, vertical and also pneumatic dispatch tubes. Also shown are tray conveyors for continuous handling of foods and dishes. 4 pp., illus. Lamson Corp., Syracuse 1, N. Y.\*

#### LITERATURE REQUESTED

The following individuals and firms request manufacturers' literature:

Basch and Sokoloff, Builders and General Contractors, 1042 Alton Road, Miami Beach 39, Florida.

Architectural and Engineering Services, P. O. Box 5021, Fountain City, Knoxville 18, Tenn.

Ralph E. Cole, Registered Architect, Suite 405, 745 Yates Street, Victoria, B. C., Canada.

Major William A. Hill, MSC, Hospital Construction Branch, Office of the Air Surgeon, Room 4A 310, Pentagon Building, Washington 25, D. C.

S. Donald Moore, Electrical and Mechanical Engineer, Box 205, Kansas City, Kansas.

Joseph F. Morbito, Architect, 429 E. College Avenue, Kent, Ohio.

Lawrence F. Pratt, Registered Civil Engineer, 231 E. Angeleno Avenue, Burbank, Calif.

Jack K. Vogel, Registered Architectural Engineer, Liberty Theatre Bldg., Wellsville, Ohio.

## Radiant heat foils weather on new bridge

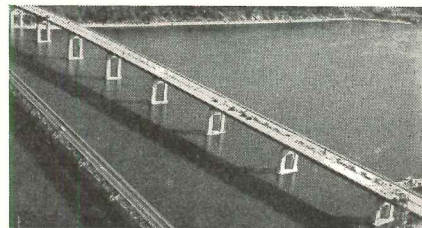

New Raymond E. Baldwin Bridge, Old Saybrook, Connecticut. Project Engineer for the State—Col. Howard S. Ives.



Roadway, morning after a storm. Clear sections remained free of snow all during storm; roadway in foreground, though scraped, is still covered with ice patches. Heating Contractor—William M. Ford; Distributor—Marsden and Wasserman.

**DISCONCERTED** is the motorist who slides through a toll gate on smooth-as-glass ice. A novel radiant heating installation eliminates this menace to motorist, attendant, fenders and toll house on this new bridge.

An oil-fired No. 240 Mills boiler supplies hot water which circulates through pipes embedded in the roadway adjoining the toll booths, melting ice and snow and keeping the roadway clear. The oil burner operates only during icing periods; at other times anti-freeze protects the system.

Usual applications like this prove the versatility and dependability of Smith-Mills boilers . . . and their ability to deliver low-cost heating year after year. Even on the toughest jobs, you're sure of satisfaction when you specify an H. B. Smith boiler. The H. B. Smith Co., Inc., 67 Main St., Westfield, Mass.

H. B.  
*Smith*  
CAST-IRON BOILERS  
Offices and Representatives in Principal Cities

# What's New and Different About The Wakefield **GRENADIER II** and **IV**?

A further standardization of parts applicable to both units has been achieved.

- a** All units are now equipped with ETL approved Brick Type Ballasts.
- b** All units are now furnished with identical mounting devices.
- c** Six catalog numbers are eliminated without reducing the models or variety of mountings.

Distributors may now maintain adequate service from stock with lower investments in inventories.

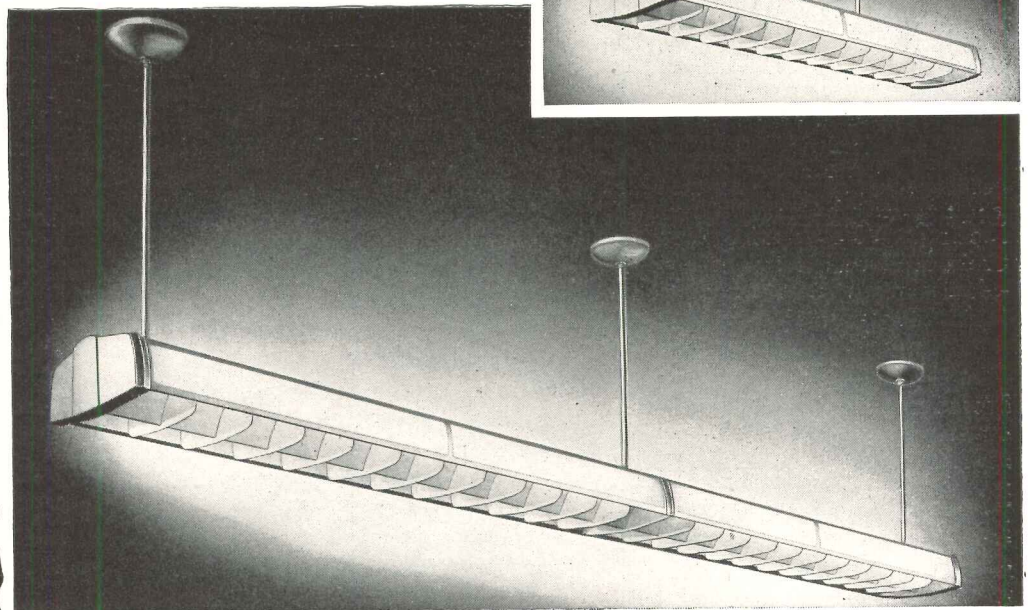
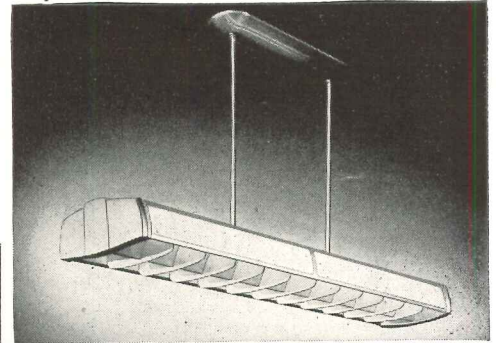

**Grenadier II**  
in Stem, Canopy and On-Ceiling styles . . . using two 40W fluorescent lamps in each 4' section.

**Grenadier IV**  
in Stem and On-Ceiling styles . . . using four 40W fluorescent lamps in each 4' section.

In classroom, office, drafting room and store installations the Wakefield Grenadier has earned respect for

- 1** its ability to provide a highly efficient type of diffused lighting;
- 2** design and construction features which make maintenance and part replacement simple and rapid, resulting in a "low cost of owning";
- 3** the quality and beauty of its construction throughout and particularly of the metal-framed plastic side panels and the soft metallic satin finish of all metal parts.

To these superiorities must now be added the new benefits of parts simplification noted above. Good news, we think, for all who stock, sell, specify and install the Wakefield Grenadier.

## Wakefield Over-ALL Lighting

A BASIC CLASSROOM TOOL



THE GRENADIER II



THE COMMODORE



THE STAR



**East Side, West Side, All Around Indianapolis**



Main Office of Indiana National Bank, Indianapolis. Equipped when originally designed by D. A. Bohlen & Son with Webster Steam Heating System. In 1947, Strong Brothers, heating contractors, modernized the installation by installing Webster Moderator System.

The Indiana National Bank, successor in 1865 to the business of the Indianapolis branch of the State Bank of Indiana, organized in 1834, has been a Webster customer for over 34 years.

Ever since a Webster Vacuum System was installed in the main office building in 1914, Webster Equipment has been purchased, keeping the bank properties abreast of the latest developments in comfort and economy in heating.

In 1947, a Webster "Controlled-by-the-Weather" Moderator System with Outdoor Thermostat was installed in the main office building. Pre-fabricated Webster Convactor Radiation with integral supply valve and trap was used.

Webster Systems of Steam Heating are also installed in three recently constructed branch office buildings.

An important factor in the success of these installations was the close association that has existed between bank management under President Russell L. White, Architect, D. A. Bohlen & Son, and Webster Representative, S. E. Fenstermaker.

The story of Webster heating in Indiana National Bank illustrates how Webster serves their customers. Let us help you with your heating.

Address Dept. AR-6

**WARREN WEBSTER & CO.**  
Camden, N. J. : Representatives in Principal Cities  
In Canada, Darling Brothers, Limited, Montreal

**Webster**  
**HEATING**

## REQUIRED READING

(Continued from page 30)

### UNKNOWN BOSSES

*Roof Bosses in Medieval Churches.* By C. J. P. Cave, M.A., F.S.A. Cambridge University Press, The Macmillan Company (60 Fifth Ave., New York 11, N. Y.) 1948. 7½ by 10 in. viii + 235 pp., illus. \$9.50.

As a relief from the mundane, day-to-day work in the architectural office, either being a boss or being bossed, this book is a delight. It is an excellent study of one of the minutiae of ecclesiastical architecture that has escaped the notice of most students or antiquarians. There seems to be an infinite variety of bosses used in the vaulting of English churches, ranging all the way from naive grotesques to sophisticated, foliated and sculptured design. One's mind can wander back through the centuries and wonder what led each of the craftsmen-designers to choose each particular subject.

The author, Mr. C. J. P. Cave, has been studying and taking photographs of carved roof bosses in churches throughout England, and the splendid results of his study are well set forth in this volume. Some 368 photographs of bosses, from a collection of more than 7000, are included as illustrations, and his text is both interesting and enlightening.

Though the height of roof bosses above the ground has made access and study difficult, it has often at the same time preserved them from the destruction, restoration, hard wear, or merely ignorant defacement, which have been the lot of many surviving works of ancient art. In this book, by the help of modern photography, we may now see and examine these hidden sculptures as they left the hand of the carver centuries ago — may see, more clearly in Mr. Cave's photographs than has been possible to any eyes before, a gallery of unspoiled medieval carved work dealing with a great variety of subjects, with biblical, religious, and secular scenes and figures, with beasts, birds, fishes, even insects, and innumerable heads, many of which must have been copied from life. In the foliated bosses, too, with their minute detail, students can trace the changes from conventional to naturalistic style, then to the undulatory leafage of the Decorated period, and finally to the square leaves of Perpendicular work.

All these details had remained for centuries dark and half-hidden until Mr. Cave with his spotlight and telescopic lens brought them down from the roof.

## The RESTORATION of COLONIAL WILLIAMSBURG

*A Reprint  
of the December, 1935  
Issue of*  
**ARCHITECTURAL RECORD**

104 pages, bound in cloth  
\$2.50 per copy

The Colonial Williamsburg Number of **ARCHITECTURAL RECORD** — issue of December 1935 — was sold out soon after publication but the entire editorial contents have been reprinted and bound in permanent book form with blue cloth covers.

Many thousands of these Williamsburg reprints have been sold but the demand continues unabated.

ARCHITECTURAL RECORD  
119 W. 40th Street, New York, N. Y.

Enclosed is \$..... for which send..... copies of your reprint, *The Restoration of Colonial Williamsburg*, bound in cloth, at \$2.50 per copy. {Add 2% Sales Tax for New York City deliveries.}

Name.....

Address.....

City and State..... A.R. 6-49

Lend us 2 Sq. Ft.  
for 20 minutes

and we'll prove to you  
the many advantages of  
Truscon Ferrobord  
Steeldeck...

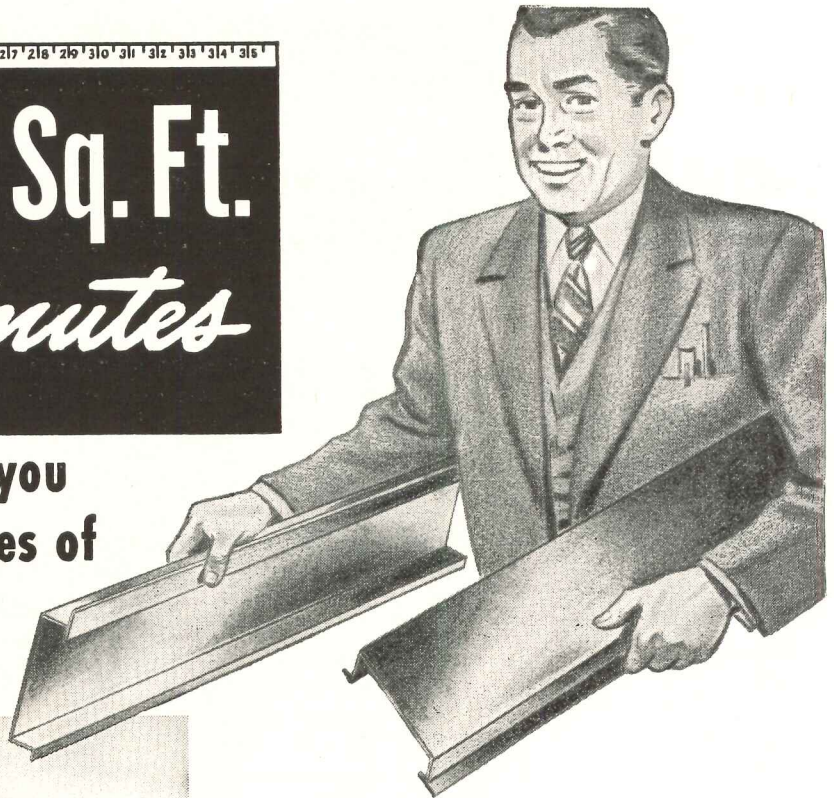

Truscon Ferrobord Steeldeck being installed in the new Automatic plant, Maytag Washing Machine Company, Newton, Iowa. Arthur H. Neumann & Bros., Inc., Des Moines, Architects, Engineers, Contractors.

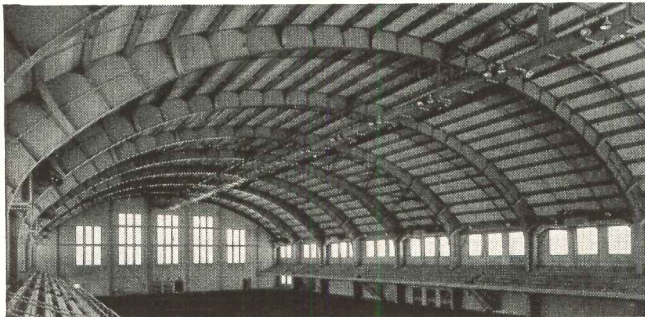

Truscon Ferrobord Steeldeck in Field House, Boy's Town, Nebraska. Leo A. Daly Company, Architects. Peter Kiewit Sons Company, Contractors.

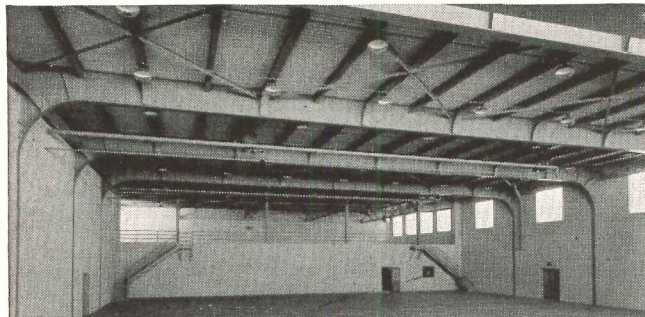

Another view of the Truscon Ferrobord Steeldeck in the Field House, Boy's Town, Nebraska.

● A Truscon Steeldeck engineer can give you a quick, convincing demonstration of Ferrobord features right on your desk top.

You can "heft" its light weight, extreme strength and unusual rigidity. Discuss the valuable "moment of inertia" factor in Ferrobord—it's highly important in developing your building plans. Here are the details:

Truscon Ferrobord is fabricated from strip steel, and is furnished in lengths continuous over three or more purlins. This provides continuity which minimizes deflection. Equally important is the fact that due to the extra amount of steel in the lower flange of the ribs the "moment of inertia" in Ferrobord is extremely high. Deflection is inversely proportioned to this "moment of inertia." The combination of continuity over the supports, and the high "moment of inertia," makes the deflection of Truscon Ferrobord very appreciably less than that of simple span decking.

Ferrobord is adaptable to flat, pitched, or curved roofs. The 1½-in. deck may be shop curved to a minimum radius of 60 ft. 0 in. and the 1¾-in. deck to a minimum radius of 75 ft. 0 in.

The Truscon Steel Company maintains branch offices in many of the large cities, and the services of Truscon engineers are available for assistance in the laying out of the steeldeck. We will be glad to cooperate with the local roofing company in the selection of the proper type of insulation and built-up roofing. Write for free descriptive literature, or ask for the interesting 2 square foot Ferrobord demonstration right in your own office.

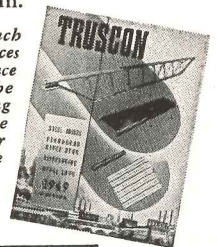

**TRUSCON**

**STEEL COMPANY**

YOUNGSTOWN 1, OHIO

Subsidiary of Republic Steel Corporation  
Warehouses and sales offices in principal cities

Manufacturers of a Complete Line of Steel Windows and Mechanical Operators • Steel Joists • Metal Lath • Steeldeck Roofs • Reinforcing Steel • Industrial and Hangar Steel Doors • Bank Vault Reinforcing • Radio Towers • Bridge Floors.

# You'll want to have this 1949 Kimsul\* Technical Booklet!

## Facts About Thermal Insulation... for Architects, Builders and Engineers!

**Flexible**—fits into corners, under hand pipes, electrical wiring and other "tight spots". No areas unprotected.

**Clean**—no sharp particles to irritate, nothing to effloresce, pty construction prevents settling or sagging.

**Caulkable**—one ply or many plies may be compressed to high density in narrow or wide joints, sealing out cold air and sound. Kimsul, asphalt-treated wood fiber does not break up during caulking or tamping operation.

**Continuous, no joints**—pre-fabricated insulation job. Positive and accurate, no intermediate joints, uniform ply construction, and extra blanket material assure a good job.

**Small Storage Space—Easy Handling**—Kimsul shipping package is small, tough—1/2" insul. volume.

Other packages are normally bulky, hard to carry and store, easily damaged.

**Objective: Comfort**—in winter, due to warmer surrounding surfaces of walls, ceilings and floors; in summer, due to protection from excessive heat.

**Attendant Benefit: Fuel Saving**—as shown above for a one-story Chicago residence.

**Insulated Fastening Edge**—Kimsul blankets are extra wide to provide fully insulated fastening edges, and to insure completely filling spaces where framing may be slightly off center.

**Over-Framing Compressibility**—Kimsul insulation, in Standard and Commercial Thicknesses, may be easily compressed over framing members. Especially valuable for 48" wide Kimsul—suitable for mass or prefabricated construction.

**Light Weight**—14 lb. per cubic foot. Standard Thick Kimsul weighs only 115 lb. per 1000 square feet.

**Moisture-Resistant**—Asphalt treatment of each ply sheds water.

**Resists Mold, Rot, Vermin**—The material of which Kimsul is made offers no substance to vermin or insects. Special chemical treatment resists mold and fungus.

**Acoustical Uses**—See pages 10-11.

**"U" Factor**—0.27" Thick, 0.10 R.F.

**Any Width, Any Length**—It's easy to cut exact lengths of narrow widths. Avoids mess and fuss. Kimsul is a fast, neat job—with speed.

**Many-Layer, Slitched**—Each ply is continuous and separate; all are held together at the density of maximum efficiency by strong stitching. No heat leaking thin spots, no money-wasting thick spots in the Kimsul blanket.

**Fire-Resistant**—Special permanent chemical treatment makes Kimsul fire proof. No insulating material can make a wood frame building fire proof, but insulation should never increase the hazard of fire.

**UNDERWINTERS**  
A. S. T. M.  
FIRE TEST

**100 sq. ft. Uncompressed Insulation Weighs 250 lbs. Kimsul Insulation**

**Pyrogard fire-resistant cover**—(exclusive Kimsul feature) protects from spread. Insulation covers and waterproofing customarily used are highly flammable and constitute a hazard, regardless of the material used for insulation.

**Table: TONS OF FUEL USED PER SEASON VS. TONS SAVED PER SEASON**

INSULATION	TONS OF FUEL USED PER SEASON	TONS SAVED PER SEASON
11" Standard Thick	11.7	4.1
11" Commercial Thick	9.3	6.7
11" Double Thick	6.4	9.6
11" Pyrogard Thick	7.6	8.4
11" Pyrogard Double Thick	2.6	13.4
11" Standard Double Thick	6.7	9.4
11" Commercial Double Thick	4.3	11.8
11" Double Double Thick	1.3	16.4

**Table: Kimsul Building Insulation**

THICKNESSES	THERMAL RESISTANCE (R.F.)	SOUND ABSORPTION (A.V.)	SQUARE FEET PER ROLL STANDARD WIDTH		APPROX. NET WT. 1000'
			18, 20, 24 INCHES	24 INCHES	
100	1.85	40	500	6	
200	3.70	55	500	12	
100	7.40	70	250	2	

**Table: Kimsul Vapor Seal Paper**

Commercial Thick rolls contain new members (100 sq. ft. each). Standard Thick and Double Thick rolls contain new members (50 sq. ft. each). Available in 36-inch width rolls to cover three corners by cutting to fit. Kimsul is a fast, neat job—with speed.

## For Your Free Copy, Mail This Coupon Today!



KIMBERLY-CLARK CORPORATION  
NEENAH, WISCONSIN

Please send me my free copy of the 1949 Kimsul Technical Book.

I am  an architect  a builder  an engineer

NAME.....

ADDRESS.....

AR-649

CITY.....

ZONE..... STATE.....



\*T. M. Reg. U. S. & Can. Pat. Off.



# ...yes, TWO for the space of one

Architecturally speaking, when you can't expand horizontally, you go up.

Bryant engineers did, twelve years ago, when they were called upon to provide gas-fired equipment in a limited space for the world's first apartment building designed to include individual suite heating.

They created the vertical winter air conditioner, and called its installation *Personalized Heating*. It was one of the few really new developments in heating in several decades, and it set a new standard for heating comfort in all types of multi-family construction.

Later, designers carried the theme a step further . . . paired gleaming white Bryant automatic water heaters with these vertical winter air conditioners;

another space-saving device that was received enthusiastically by planners of multi-family and individual family dwellings alike.

It is a matter of record that these Bryant *Personalized Heating* systems have been all that they were meant to be, from the standpoint of both cost and comfort. In less space than is normally required for conventional space heating equipment alone, these slim Bryant quality units provide a complete automatic heating and water heating service, economically and surely.

They are an aid to design and construction—and your Bryant Distributor stands ready to lend his aid in helping you to incorporate this efficient, space-saving equipment into your new plans.



Let the pup be furnace man  
... and water boy, too!

# bryant

**AUTOMATIC HEATING**

**BRYANT HEATER DIVISION**  
**AFFILIATED GAS EQUIPMENT, INC.**  
 Cleveland, Ohio • Tyler, Texas

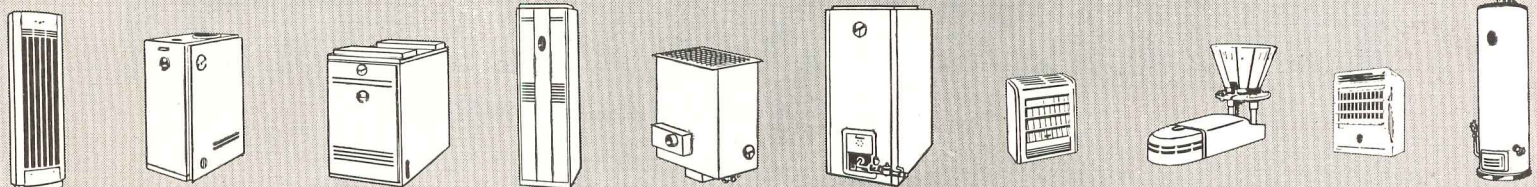

**THE MOST COMPLETE LINE OF GAS HEATING EQUIPMENT IN THE NATION**

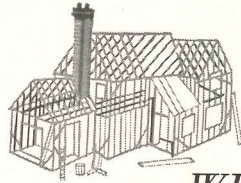



*THE HOUSE  
WITH NO  
GROWING PAINS*

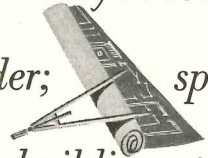

*The owner-built house*  *grows smoothly from cellar to chimney... because it is owner-planned. It begins with blueprints-to-order;*  *specifications that meet the owner's demand for highest building standards.*  *In short, it is the house that your quality building product is made for.*

House & Garden readers are an owner-builder market in the making. 60%\* of them have collected house plans; 44% have purchased land; 27% have consulted architects. Whatever goes into their houses must meet specifications of top quality, top taste because House & Garden readership represents America's families of top taste and top income. Reach the people who have the power to specify *your* quality product... through the magazine they turn to as their authority on building.

*\*of the 43% who plan to build.*



# House & Garden

*...for the Owner-Builder market*



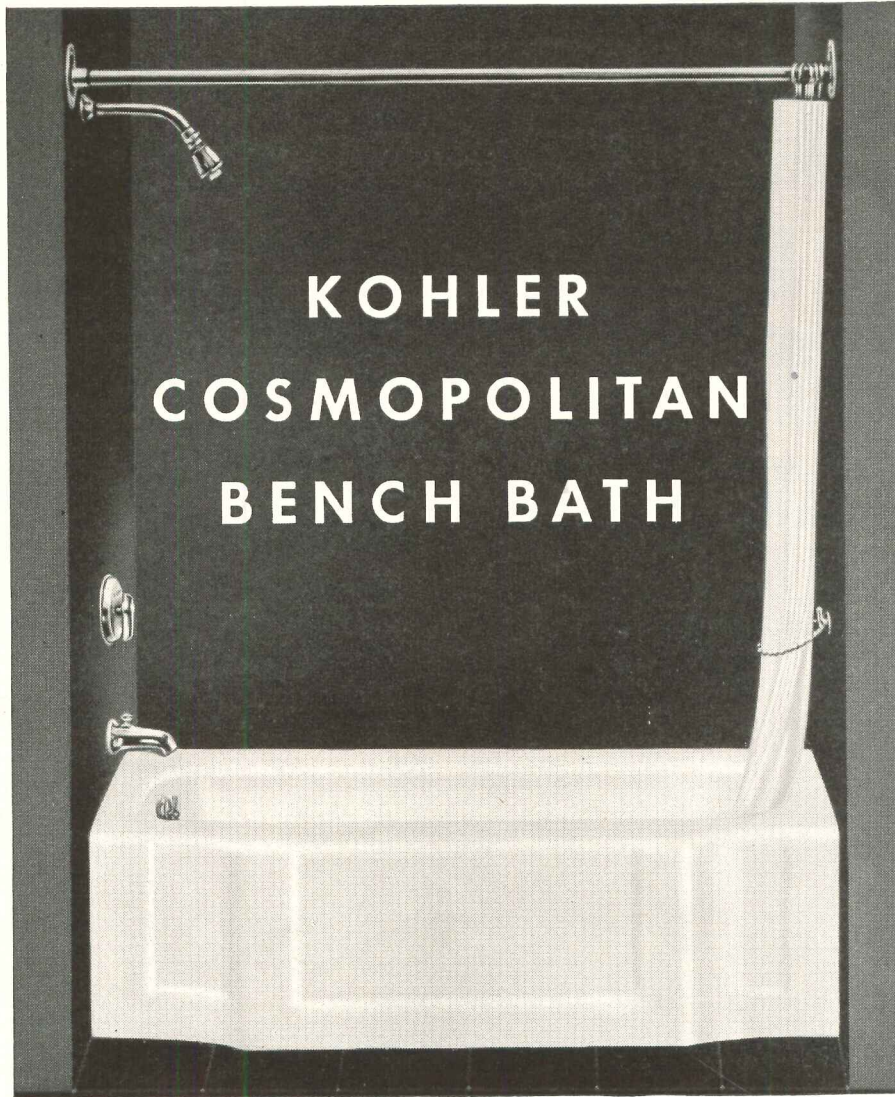

## **KOHLER ENAMEL OVER NON-FLEXING IRON . . . CAST FOR RUGGED STRENGTH AND RIGIDITY**

The Kohler bath, with its time-tested base of iron, has the proper weight and solidity to assure a firm, tight installation. The Kohler enamel fuses securely to the iron surface, forming a smooth, lustrous coat that is acid-resisting, easy to clean and extremely durable. The fact that the iron base is non-flexing minimizes danger of cracking and crazing. Home owners appreciate the freedom



from noise and the sturdiness of Kohler baths. Kohler fixtures and fittings have a quality reputation confirmed by 76 years of outstanding satisfaction in American homes and institutions. Every Kohler product is made of thoroughly tested materials—and designed and manufactured to give practical, reliable service. Kohler Co., Dept. 8-H, Kohler, Wisconsin.

# **KOHLER OF KOHLER**

**PLUMBING FIXTURES • HEATING EQUIPMENT • ELECTRIC PLANTS**

# AGITAIR

goes to . . .

HARVARD



Lamont Library at Harvard University with acoustical ceiling, modern lighting and versatile Agitair Type R's that blend perfectly with surroundings.

Architects: Coolidge, Shepley, Bulfinch & Abbott.  
Heat. & Air Cond. Eng.: Buerkel & Co., Inc.

### Here's the Secret of Greater Diffusing Ability:

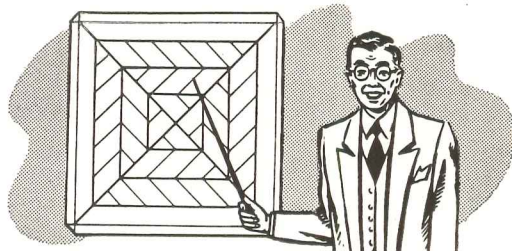

Patented built-in diffusing vanes deflect the air in numerous divergent streams resulting in turbulence at the point of contact with the aspirated air. Result: Rapid mixing, diffusion and temperature equalization.

Quiet and comfort are musts in a college library. That's why you'll find Agitair Type R's providing noiseless, draftless air diffusion at Lamont Library, Harvard. These diffusers assure 100% air distribution in any shape area from any location . . . blend perfectly with modern architectural treatments.

*Write for Complete Data*

**AIR DEVICES, INC.**  
17 East 42nd St. • New York 17, N. Y.  
AIR DIFFUSERS • AIR FILTERS • ROOF EXHAUSTERS

# NEW METHOD OF FIREPROOFING SLASHES COSTS— SAVES DAYS OF CONSTRUCTION TIME

Prudential Insurance Company Office Building, Los Angeles  
Fireproofed with Zonolite vermiculite plaster on beams and interior columns. Applied 1" thick on metal lath.  
Walter Wurdeman and Welton Becket, Architects  
Murray Erick Associates, Structural Engineer  
Wm. Simpson Construction Co., Gen'l Contractors  
Reischel and Cottrell, Lathers and Plasterers



## ZONOLITE\* VERMICULITE PLASTER Reduces Structural Steel Requirements Up to 15%

Now the job of fireproofing can be done at far less cost . . . *in far less time* . . . with lightweight ZONOLITE Vermiculite Plaster.

Today many leading architects and structural engineers are dispensing with old, cumbersome methods of fireproofing which employ heavy concrete or masonry. They have found ZONOLITE vermiculite fireproofing *the best, the easiest, and the least expensive.*

### CUTS COSTS...SOLVES BUILDING PROBLEMS

When ZONOLITE plaster is used for fireproofing, the cost of applying lath and plaster approximates the cost of merely *building the forms* for ordinary fireproofing. And because ZONOLITE plaster saves tons of dead weight

in construction, structural steel requirements can often be reduced as much as 15%! Actually saved \$235,000 in one building, in addition to many days of construction time.

Extra stories can be built on foundations or on existing structures by using Zonolite.

### WHY ZONOLITE GIVES THESE SAVINGS

ZONOLITE plaster fireproofing on a typical beam weighs *less than one-tenth* as much as ordinary fireproofing materials. ZONOLITE insulates and protects against fire up to four times as well as ordinary plaster.

ZONOLITE plaster provides lightness, insulation, and fire resistance found in no other material.

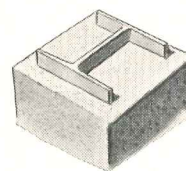

Old Method of Fireproofing with Heavy Concrete

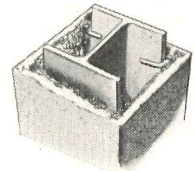

New Method of Fireproofing with ZONOLITE Vermiculite Plaster

### 4-HOUR UNDERWRITERS' RATING FOR VERMICULITE PLASTERED STEEL COLUMN

In a recent Underwriters' Laboratories test for the Vermiculite Institute a steel column with Vermiculite plaster obtained a 4-hour rating—actually withstood test about 4¾ hours before failure. Details on request.



**ZONOLITE  
COMPANY**

135 S. LaSalle St.  
Chicago 3, Illinois

Member of  
Vermiculite Institute

### MAIL COUPON FOR NEW FREE BOOKLET!

Zonolite Company, Dept. AR-69  
135 S. LaSalle St., Chicago 3, Ill.

Please send me a free copy of your booklet, "VERMICULITE PLASTER FIREPROOFING."

Name.....

Address.....

City..... State.....

\*Zonolite is a registered trade mark of Zonolite Company

Available



Again

# TIME-SAVER STANDARDS

Architectural Record's ten-year collection . . . all in one volume

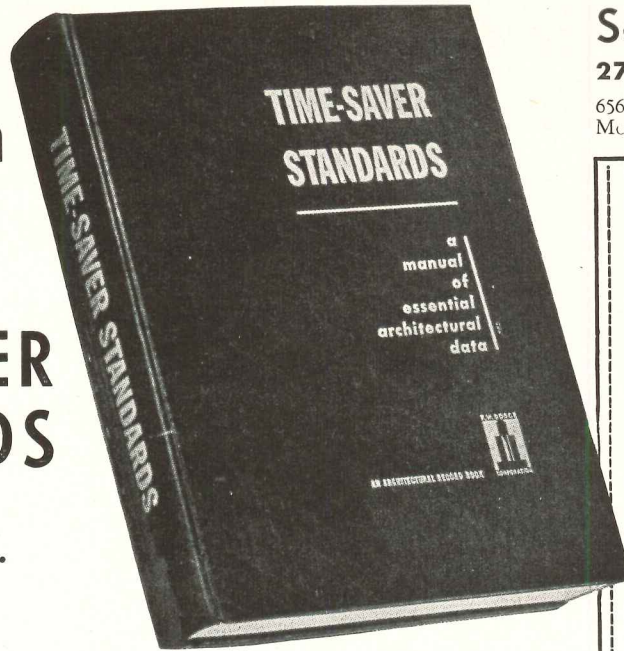

## Second Printing

277 Time-Saver Standards —

656 Pages; 12-Page Master Index: Size 8½ x 11. More than 1,000 illustrations, charts, diagrams

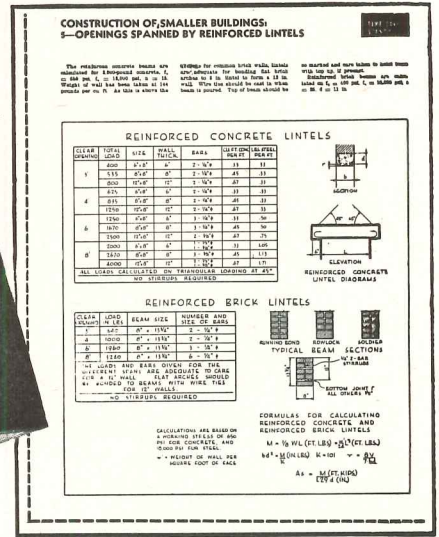

IN RESPONSE to insistent demand for more copies, here, reprinted again in one volume of encyclopedic size, are virtually all the Time-Saver Standards ever published — 277 of them — exactly as they appeared originally in *Architectural Record* and *American Architect* during the past ten years — with one 12-page master index!

Just off the press, for immediate delivery to you, is this work of 656 pages, with a mailing weight of 4½ lbs., containing a complete collection of these now famous authoritative monographs on technical aspects of construction dealing with

- Architectural Design
- Materials Technology
- Engineering Data
- Building Practice

Designed for the practical guidance and every-day use of architects, engineers, specification writers and building technicians, TIME-SAVER STANDARDS will bring you a wealth of detailed information on design and building practice . . . carefully selected from the works of the nation's leading building designers and engineers.

### Well-Organized 12-page Index

This wealth of data is carefully organized and painstakingly presented. It is so thoroughly indexed that there are 1,856 references and cross-references . . . occupying twelve pages of closely set print.

Experience shows that a single item in TIME-SAVER STANDARDS can well save hundreds of dollars in economy construction . . . save many hours of your valuable time. Yet you can now place this concise and well-organized planning data at your command for the nominal sum of \$12.00 — provided you act now.

### Order Your Copy Now

The first printing of TIME-SAVER STANDARDS last November was sold out almost before publication. Now an unanticipated flood of re-orders — for extra copies and multiple copies — on top of new orders indicates the second printing will soon be snapped up.

So get your copy now. Don't get caught on a long waiting list. Simply fill out the coupon at right, attach your check or money order for \$12.00, and mail today. Your copy will be rushed to you without delay.

These telescopic outlines of only a very few of the 277 Standards give a quick idea of the detailed treatment accorded each subject.

**Dry-wall Construction.** Materials applicable. Fiber board. Fiber insulation board. Planks and tileboards. Hardboard, Gypsum wallboard. Plywood. Cement asbestos Plastics. Composite and self-supporting walls and partitions . . . Advantages. Handicaps. Costs. Terminology. Classifications and sizes. Framing and furring. Joints. Nailing and cementing. Flexible fasteners. Finishing. Simplified practices. Uses. Applications. References.

**Heating—Unit Heaters.** Typical Heat sources. Boiler capacity. Characteristics. Location. Selection data. Capacities. Controls. Fresh Air connections. Pipe connections. Louvers. Grilles. Deflectors.

**Basement Waterproofing.** Impermeability of concrete cracks and joints in masonry. Hydrostatic pressure. Recommended concrete mixtures. Effect of curing time on permeability. Integral and membrane methods. Plastic and iron coating. Cement-base coatings.

**Folding Partitions.** Center hung doors. Pair-operated doors. Pockets. Passage through closed partitions. Door construction and soundproofing. Rolling partitions. Folding fabric partition.

**Lighting.** Recommended levels of illumination. Fixtures for filament and mercury lamps. Luminaire spacing. Room index. Coefficients of illumination. Layout suggestions. Conformity with structural design. Computed values of illumination. Lumen output of lamps.

**Noise Reduction Acoustical Materials.** A rule-of-thumb answer to what noise coefficient to use. Special applications. Materials for plastic application. Costs Appearance. Design. Fire resistance. Light reflection. Heat transmission. Lighting. Pre-cast materials. Effect of paint. Acoustical Units: Wood framing; metal suspension systems.

ARCHITECTURAL RECORD BOOK DEPARTMENT  
119 West 40th Street, New York 18, N. Y.

Enter my order for \_\_\_\_\_ copies of the second printing of the 656-page TIME-SAVER STANDARDS at \$12.00\* a copy. I enclose \$\_\_\_\_\_

\*Add 24 cents for New York City delivery — \$12.24 in all.

Name \_\_\_\_\_

Address \_\_\_\_\_

City \_\_\_\_\_ Zone \_\_\_\_\_

State \_\_\_\_\_

# NEW! Day-Brite's FOUR-BY-FOUR unit

*Incorporating the most advanced principles of integrated lighting... offering new architectural possibilities*

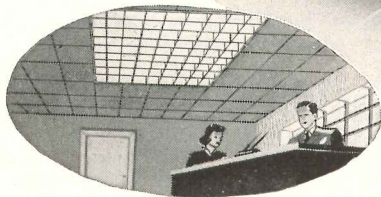
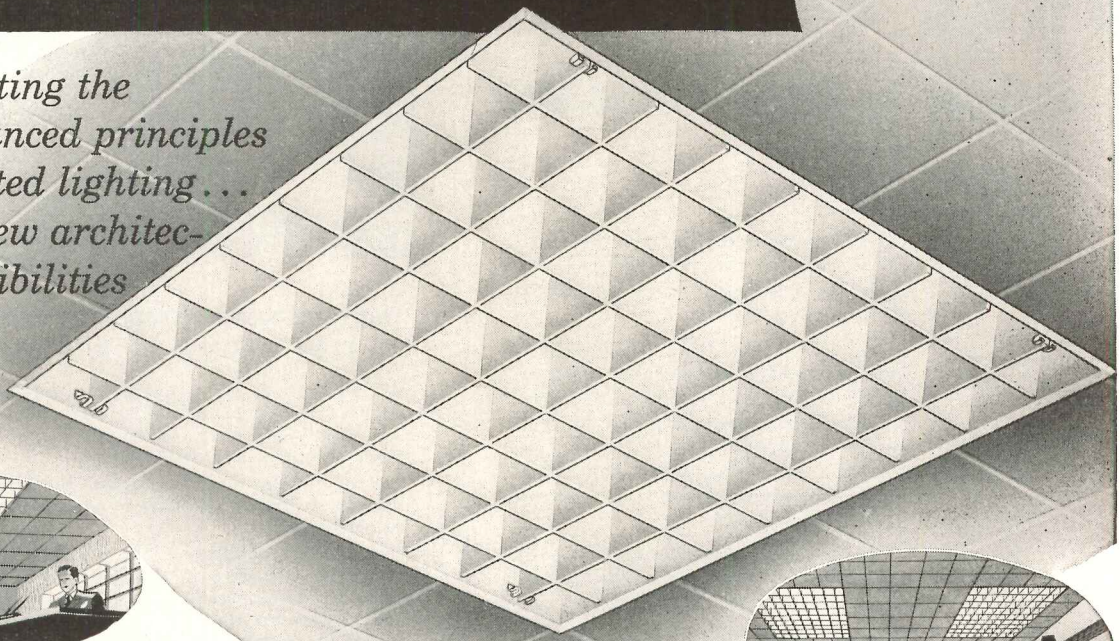

**FOR OFFICES**

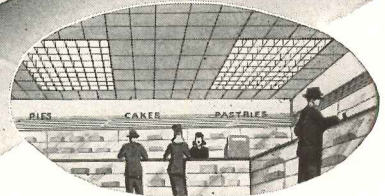

**SMALL RETAIL STORES**

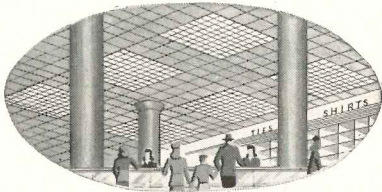

**LARGE DEPARTMENT STORES**

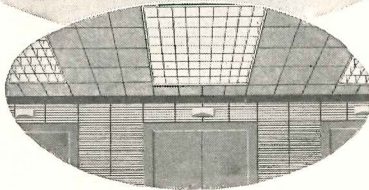

**ENTRANCES, LOBBIES**

**Day-Brite's Four-by-Fours** are engineered for both recessed and surface mounted applications. They can be used with 6, 8, and 10 40-watt fluorescent lamps. Knockouts are provided for feed connections. Plaster frames are available for use when fixtures are recessed.

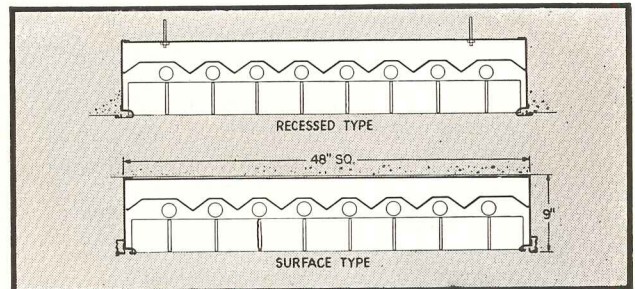

**Separable hinges** on both sides of louvers allow hinging from either side for easy servicing. Exclusive Day-Brite BOXCO louver assembly has double-wall louvers interlocked for extreme strength and rigidity. Fixtures are rust-inhibited and finished in Hot-Bonded Super-White enamel throughout.

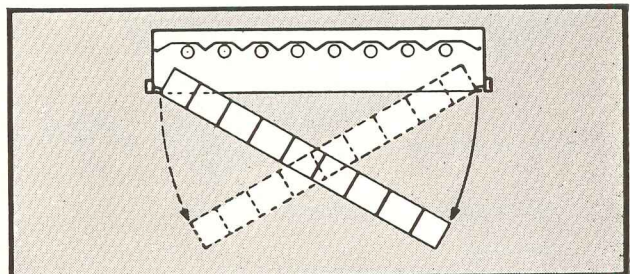

IT'S EASY TO SEE WHEN IT'S

**DAY-BRITE**  
*Lighting*



**Write NOW for descriptive Bulletin 20-C**

Day-Brite Lighting, Inc., 5465 Bulwer Avenue,  
St. Louis 7, Missouri

In Canada: Amalgamated Electric Corp., Ltd.,  
Toronto 6, Ontario

# FREE BULLETIN

## on how to drain corrosives

This 12-page bulletin tells you how, why and where you should use Duriron acid-proof drain equipment for corrosive wastes.

It includes—the physical, mechanical and corrosion-resisting properties of Duriron compared to other materials... engineering data on Duriron equipment... application in chemical laboratories, engraving plants and industrial acid waste systems... proper installation practice.

*Find out how you can protect your waste disposal system against costly corrosion. Use the coupon, today.*

**The Duriron Co., Inc.**  
Dayton 1, Ohio  
Branch Offices in  
Principal Cities

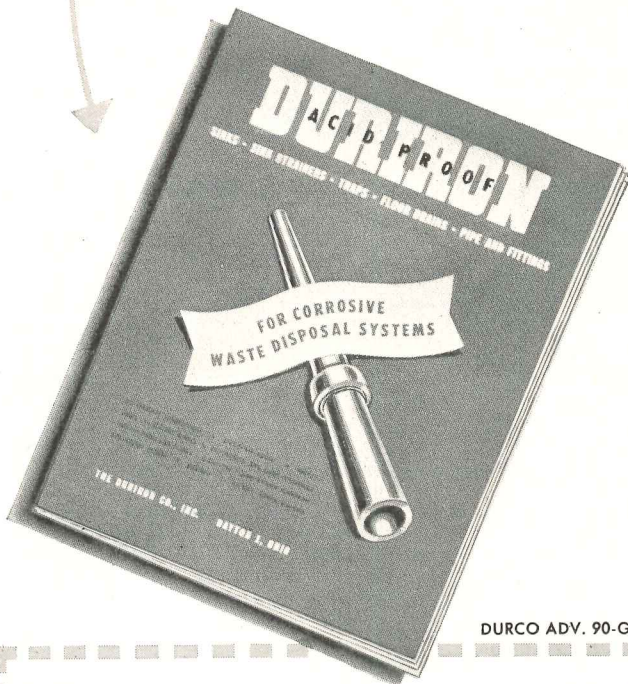

DURCO ADV. 90-GM

**The Duriron Co., Inc., Dayton 1, Ohio**

Gentlemen:

Please send me your free bulletin 703.

Name \_\_\_\_\_

Company \_\_\_\_\_

Address \_\_\_\_\_

City \_\_\_\_\_ State \_\_\_\_\_



**this moisture-resisting high voltage insulation**  
**TIME-TESTED in 21 years' service**

A vital factor in the wide and growing use of Okolite-Okoprene cable is its known reliability. The oil base insulation, Okolite, has proved itself over a span of 21 years — continuing to serve in many of its original installations.

An important ingredient in the Okolite compound is Up-River Fine Para Rubber, the type of natural rubber best suited to use in a dielectric.

In Okolite-Okoprene cable, the thickness of the insulation is accurately controlled by Okonite's exclusive strip insulating process. The Okolite insulation along with the Okoprene covering, receives one uniform vulcanizing "cure" — and one alone — in this way avoids the life-limiting effects of double vulcanization.

Write for Bulletin AR-1035 which discusses the many Okolite advantages. Address The Okonite Company, Passaic, New Jersey.

**OKONITE** OKONITE SINCE 1878  
**insulated wires and cables**

7456

The fifth of a series in the interest of more efficient use of steel... a vital American resource.

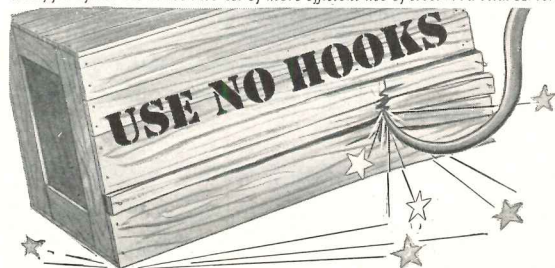

**ON BOXES or REINFORCING BARS!**



Old style reinforcing, with localized anchorage — conducive to widely spaced open cracks.

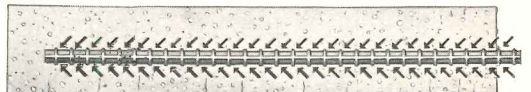

Laclede Multi-Rib Bars adequately transmit stresses to concrete by uniformly distributed anchorage. Small, closely spaced cracks do not open under load.

The hook, which has been the symbol of bond strength in 30 year old codes has been succeeded by the balanced design of reinforcing bar deformations specified in ASTM Specification A 305-47 T. The balanced design and distributed strength of Laclede Multi-Rib Reinforcing Bars meet these new requirements—assure a more efficient use of steel and a better job!



Modernize your specifications — with ASTM A 305-47 T and Laclede Multi-Rib Bars!

**LACLEDE STEEL COMPANY**

St. Louis, Mo.

REV. 1. ACCESS. RAMP.  
REMOVABLE. RAILING.  
NOTE: SEE DETAIL 36. SHEET #10.

**ARCHITECTS:**  
Armstrong, Furst & Tilton  
Chicago

**ENGINEERS:**  
Neiler, Rich & Bladen  
Chicago

**ELECTRICAL CONTRACTORS:**  
Wadford Electric Co.  
Chicago

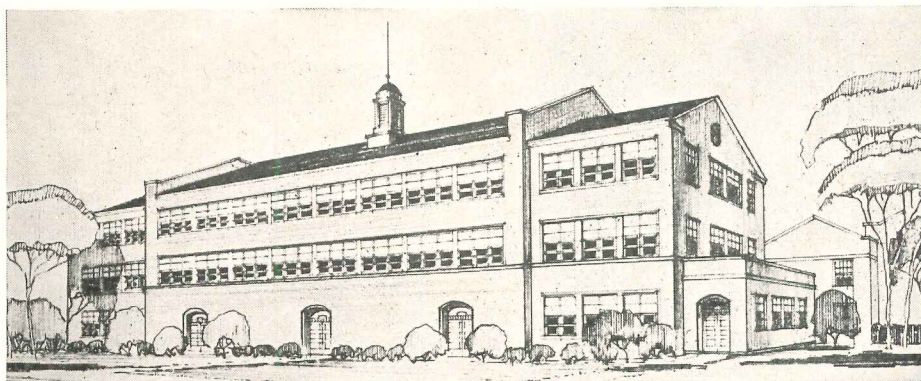

## Writing responsibility into the specifications...

• Your responsibility in specifying signal and protection systems for schools is three-fold:

(1) Personnel must be spared the nuisance of setting clocks and ringing bells. (2) Maintenance must be kept to a minimum. (3) Parents must know their children are in a safe, efficiently run school.

More and more architects are meeting this responsibility by specifying EDWARDS... thereby assuring unexcelled efficiency in clock and

program systems and constant dependability in fire alarm protection.

In the new Music Building (pictured above) of the New Trier Township High School, Winnetka, Ill., as in so many schools, Edwards performance is guaranteed by an unmatched, 77-year record of experience, design and manufacture.

This experience in developing efficient, safe signal systems now sets the standards by which all similar equipment must be judged.

### UTMOST PROGRAM FLEXIBILITY

The more varied the daily school program, the more important an Edwards Clock and Program system becomes. With Edwards equipment, signals can be operated at one-minute intervals—24 hours a day—7 days a week!

Send for special bulletins on Edwards signaling, communication and protection systems.

**EDWARDS CO., INC., Norwalk, Conn.**  
In Canada: Edwards of Canada, Ltd.



# EDWARDS

centrally-controlled  
**CLOCK  
SYSTEMS**

Electrical Signaling, Communication and Protection for Schools, Homes, Hospitals, Offices and Industry

10-10-49. ELECTRICAL CONDUIT RUN.	47-1	JOHN P. ARMSTRONG	DRG. No.
10-2-49. GENERAL REVISIONS	DATE.	ARCHITECT	A-3
	2-1-49.	721. 10. WMO. ST.	SCALE
		ARMSTRONG & TILTON	1/4" = 1'-0"

## TERRAZZO in action



# Terrazzo

the permanent theatre feature,  
outlasts the brightest stars

Theater owners with a sharp eye for long-run attractions can't find a better floor than Terrazzo. Marble-hard and concrete-durable, Terrazzo easily withstands the year-in, year-out tramping of thousands of feet. Versatile as an architect's imagination, Terrazzo patterns color and design to exact needs.

Maintenance costs—for floors, stairs, wainscots, or walls—are negligible. Specify Terrazzo and get inviting surfaces that are easy to clean, and free from refinishing or painting needs.



Write for free AIA Kit—  
the complete reference work  
about Terrazzo.

## THE NATIONAL TERRAZZO AND MOSAIC ASSOCIATION, INC.

1420 New York Avenue, N. W., Dept. R, Washington 5, D. C.

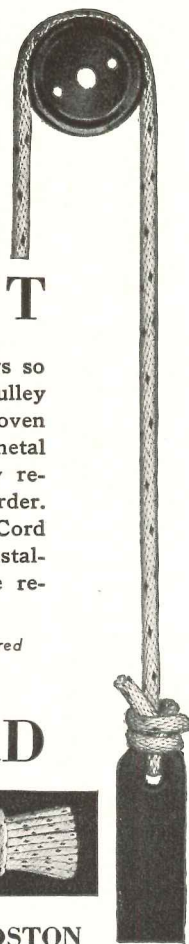

## PERMANENT

There is no method of hanging windows so trouble-free as the cord, weight and pulley method—it has been time tested and proven in service. No adjustments, no metal to metal contacts—therefore no noise, no early replacements, nothing to get out of order. Proper installation using Spot Sash Cord means a lifetime of service, reasonable installation cost and avoidance of expensive replacement.

Specify Spot Sash Cord — identified by the colored spots, our trademark (Reg. U. S. Pat. Off.)

## SPOT sash CORD



SAMSON CORDAGE WORKS • BOSTON

## HERMAN NELSON CENTRIFUGAL FANS

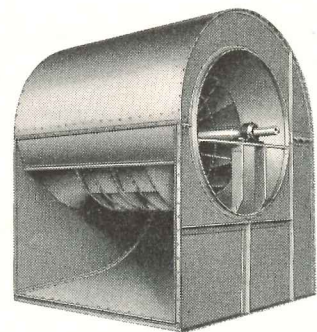

Herman Nelson Centrifugal Fans are especially designed and constructed for ventilating and air conditioning systems in all types of industrial, commercial and institutional buildings. The complete line makes the right fan available for any system requiring the use of a Class I or Class II Centrifugal Fan. Both slow speed and "non-overloading" types may be obtained for either clockwise or counter-clockwise rotation. The line includes both single inlet, single width, and double inlet, double width models. Seventeen sizes have wheel diameters from 12 $\frac{1}{4}$ " to 73". Specify these quality centrifugal fans for long, economical, trouble-free service.

Write for Bulletin 2526



## THE HERMAN NELSON CORPORATION

Since 1906 Manufacturers of Quality Heating and Ventilating Products  
MOLINE, ILLINOIS



# DU PONT ANNOUNCES

# A New and Improved

# Wood Preservative

# COPPERIZED

# CZC

(Chromated Zinc Chloride)

## Gives even longer-lasting all-round protection

Now—timber and lumber can have even greater service life than has been obtainable with standard CZC (Chromated Zinc Chloride) treatment. New Du Pont *Copperized CZC*—backed by ten years of laboratory research and field testing—gives promise of being the best all-round salt-type wood preservative ever developed.

In addition to showing far greater preservative effect than standard CZC (Chromated Zinc Chloride), this outstanding new *Copperized* product offers all these same advantages:

- Decay resistance
- Termite repellence
- Fire retardance
- Cleanliness
- No odor
- Safe to handle
- Easy to paint

### THESE 6 SIGNIFICANT TESTS SHOW ITS EFFECTIVENESS

1. Leach block test
2. Hardware corrosion test
3. Accelerated service test
4. Pilot plant treatments
5. Strength tests
6. Glow tests

Clip coupon for more facts on new *Copperized CZC*. E. I. du Pont de Nemours & Co. (Inc.), Grasselli Chemicals Dept., Wilmington 98, Delaware.



REG. U. S. PAT. OFF.

BETTER THINGS FOR BETTER LIVING  
... THROUGH CHEMISTRY

## COPPERIZED CZC

(Chromated Zinc Chloride)

E. I. du Pont de Nemours & Co. (Inc.)  
Grasselli Chemicals Department—AR-1  
Wilmington 98, Delaware

Please send me more facts on new *Copperized CZC*.

Name \_\_\_\_\_ Title \_\_\_\_\_

Firm \_\_\_\_\_

Street \_\_\_\_\_ State \_\_\_\_\_

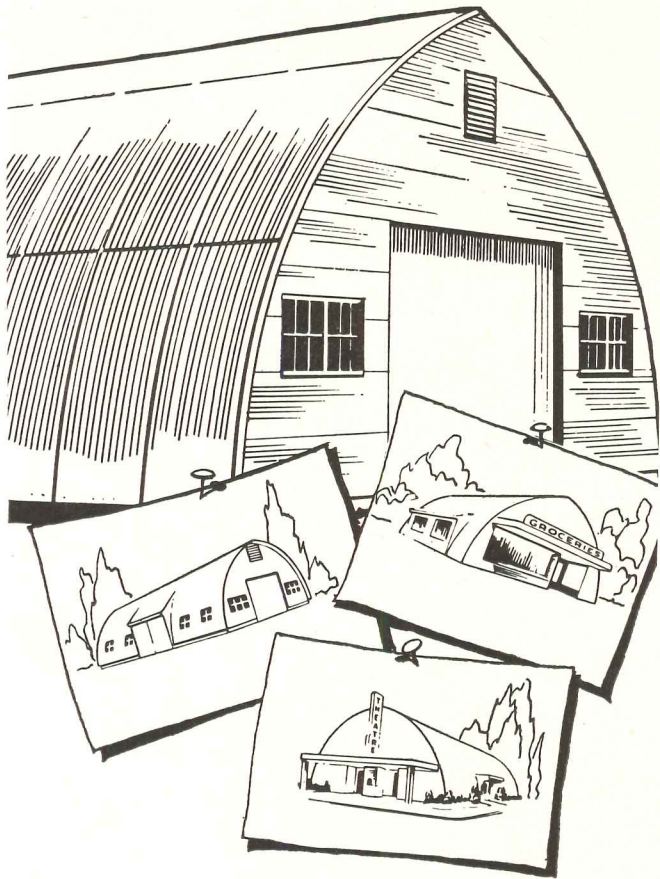

## Timberib® 40

### THE STANDARD PACKAGED BUILDING ADAPTABLE FOR 1000 USES

Add your architectural treatment to a basic unit that combines completely usable space, modest cost and quick erection time, and you have the answer for building store and shop buildings, warehouses, gymnasiums, theatres, and buildings for countless other purposes. You can do this with Timberib 40.

**Low Cost.** Factory prefabricated without waste of time or material, packaged for quick, easy erection.

**Permanent.** Glued laminated arches at 4-ft. centers which form both roof and side walls will not twist, shrink or check. Ribbed like a ship's hull.

**Versatile.** Standard building is 40 feet wide and any desired length in multiples of 4 feet. Ribs only are available for buildings from 12 to 75 feet wide. Special architectural effects may be added to meet requirements of special applications.

**Clear Floor Space.** No posts or supports of any kind obstruct floor or storage space, and interior arrangements are governed only by the functional uses of the building.

For further information about Timberib 40, consult the Timber Structures office or dealer nearest you, or write us direct.

## TIMBER STRUCTURES, INC.

P.O. BOX 3782, PORTLAND 8, OREGON

Offices in Boise, Idaho; Eugene, Oregon; Lawrenceville, N.J.; Chicago; Dallas; New York; Seattle; Spokane

TIMBER STRUCTURES, INC. OF CALIFORNIA • Oakland and Sacramento  
Local representatives coast to coast.

Ask **STEWART** Engineers  
about equipment for  
your Jail and Prison Plans

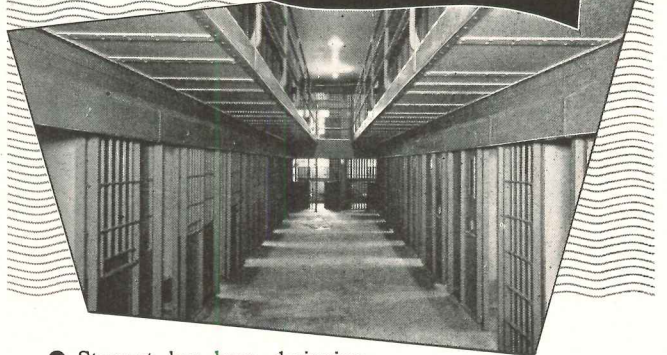

● Stewart has been designing and building jail and prison equipment for more than sixty years. Here you will find men who have the "know how" for work of this character, and it will pay you to talk over your plans with them. Stewart numbers among its installations some of the largest penal institutions in this country . . . and the smallest, too. Write for the Stewart jail specification brochure, available to architects only.

*Stewart* IRON  
and WIRE  
FENCES

THE STEWART  
IRON WORKS CO., Inc.  
1677 Stewart Block  
CINCINNATI 1, O.

Experts in Metal Fabrications Since 1886



"The Edge You Need...  
ON ALL  
1/4" MATERIAL"

**Chromtrim #7010**

Yes, for all-around utility, CHROMTRIM'S #7010, 1/4-in. quarter round cove moulding is the ONE shape that always gives you "the edge that you need." It can be used in the place of wood . . . and gives you an "extra profit edge," too!

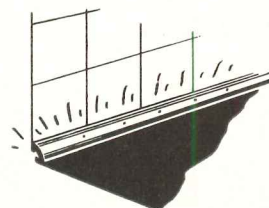

Write for free sample  
of CHROMTRIM #7010.

**Applications Galore  
.. and you'll discover  
more!**

Use it as cove, an edging . . . as a trim on any 1/4-inch material! Made-to-order for acoustical tile, wallboard, linoleum, plywood and all similar working materials.

**R. D. Werner Co., Inc.**

295 Fifth Ave. • New York 16, N. Y.

for appearance...



*Simple, unobtrusive design  
blends with any architectural treatment.*

for performance



*Adjustment features insure  
positive control of air movement.*

**Kno-Draft**

*... adjustable air diffusers  
help solve problems  
of both form and function.*

**FREE HANDBOOK**—Send for FREE copy of new handbook on air diffusion. Complete information on Kno-Draft Adjustable Diffusers and all necessary engineering data to help you create “custom-made” air patterns. Just fill in and mail the coupon.

**W. B. CONNOR ENGINEERING CORP.**

*Air Diffusion • Air Purification • Air Recovery*

112 East 32nd Street  New York 16, N. Y.

IN CANADA: Douglas Engineering Co., Ltd., 190 Murray Street, Montreal 3, P. Q.

**W. B. CONNOR ENGINEERING CORP.**

Dept 5-30, 112 East 32nd Street, New York 16, New York

Please send my FREE copy of the new Kno-Draft Handbook on Adjustable Diffusers.

Name.....

Position.....

Company.....

Street.....

City..... Zone..... State.....

## royal jet-flow

outperforms heating units  
costing three times  
as much\*



**HENRY I. FLINN JR.**  
says: "The Royal Jet-Flow  
is doing a stupendous job  
. . . . The unit has far  
exceeded our greatest  
expectations. We have had nothing but praise  
from each one of the 200 tenants . . ."

FOLMAR & FLINN  
Operative Builders  
Montgomery, Alabama

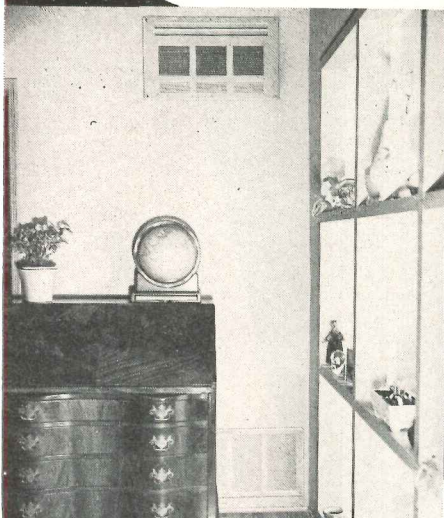

\* Proved by tests conducted in America's  
Finest Independent Laboratory. Royal Jet-Flow  
uses jet principle and high outlet delivery  
to achieve a velocity of 300 feet per minute.  
Heats entire average size house with a mini-  
mum differential from room to room. Royal  
Jet-Flow costs only slightly more than a floor  
furnace—much less than forced air.

write today for complete information

**royal heaters, inc.**

1024 WESTMINSTER AVENUE  
ALHAMBRA, CALIFORNIA

## IMPORTANT INFORMATION ON BANK VAULTS

FREE ON REQUEST!

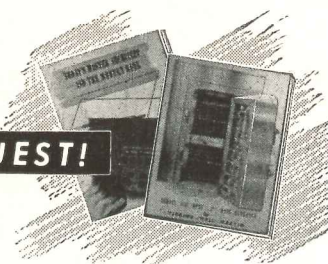

Here is worthwhile  
information every  
bank architect  
should have on file:

● *Brief outline of fundamentals in modern architectural techniques of bank vault design attractively presented in a well-illustrated folder . . . "Today's Master Architect and the Modern Bank."*

● *Complete specifications manuals for 7½", 10", 12" and 16" bank vault entrances with the exclusive and revolutionary interlocking vestibule.*

Write today for your copies. Specify manual or manuals you want.

## HERRING-HALL-MARVIN SAFE COMPANY

General Offices & Factory  
HAMILTON, OHIO

**STOP** that **WATER**  
with FORMULA # **640**

A clear liquid which penetrates  
deeply into masonry surfaces.

The hydrocarbon solvent evap-  
orates, leaving the pores filled  
with a balanced formula of seven  
different waxes and resins.

See our catalogs in SWEET'S  
Architectural Files  $\frac{9a}{9}$  and En-  
gineering Files  $\frac{4f}{3}$  under Water-  
proofing and Dampproofing.

WRITE OUR ENGINEERING DEPARTMENT for  
office test kit, technical data, or regarding  
any special problem

J. Wilbur Haynes, Engineer

**HAYNES PRODUCTS CO.**

4007 FARNAM STREET • OMAHA 3, NEBRASKA



# Mesker Steel Windows



GOVERNMENT OF PUERTO RICO  
 ADMINISTRACION GENERAL de SUMINISTROS  
 San Juan, Puerto Rico  
 Architect  
 Schimmelpfenning, Ruiz and Gonzales, Santurce, P. R.  
 Contractor  
 Gaya, Fuentes Construction Co., Inc., San Juan, P. R.  
 Mesker Sales Engineer  
 Prisco Jimenez, Jr., San Juan, P. R.

Office buildings house *people*. That's why the thoughtful architect, when designing offices, considers the psychological advantages of steel windows. Every office worker, for example, prefers to work alongside a window—rather than in an inside room. So do you! Thus many of the new office buildings today are like that shown here. Equipped with Mesker Steel Windows, this project provides a maximum of natural light and controlled draftless ventilation. Ask your Mesker Sales Engineer to show you similar jobs in your vicinity. They're frequently worth your intensive study!

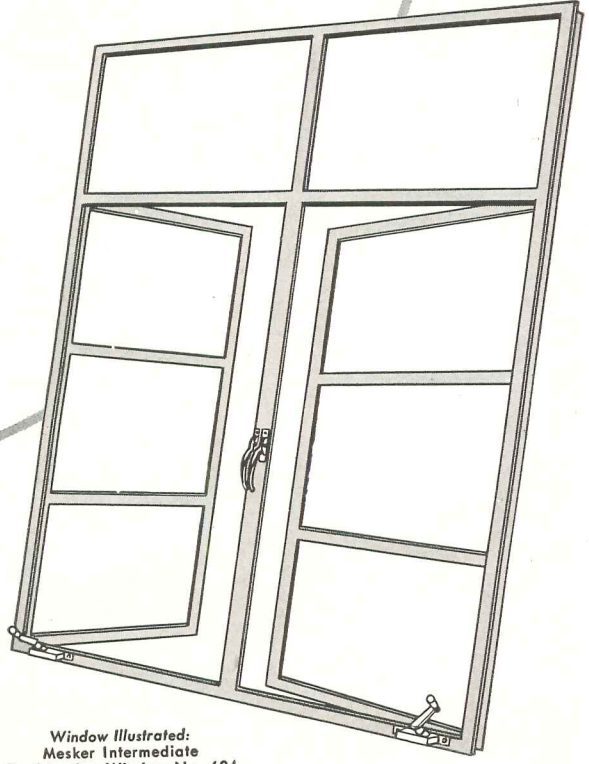

Window Illustrated:  
 Mesker Intermediate  
 Combination Window No. 624

### MESKER INTERMEDIATE COMBINATION WINDOWS

These popular steel windows have been installed in some of the country's leading schools, banks, factory offices, stores and public buildings. Members 1 $\frac{3}{4}$ " deep are extra heavy, extra strong. Available with and without hopper ventilators in a wide range of heights and widths. See the Mesker Catalog in Sweet's, or write for detailed data sheets.

MESKER BROTHERS • 4338 GERALDINE AVENUE • SAINT LOUIS 15, MISSOURI

# CASTELL



World's  
Finest  
**DRAWING  
PENCIL**

18 degrees 7B to 9H

Still at

Pre-war Price

15¢ ... less in quantity

A NAME FAMOUS

SINCE 1761

**A.W. FABER-CASTELL**  
PENCIL COMPANY INC., NEWARK 4, N.J.

**METAL FOR STORE FRONTS**  
FULLY EXTRUDED  
ALUMILITED ALUMINUM

## Latcor

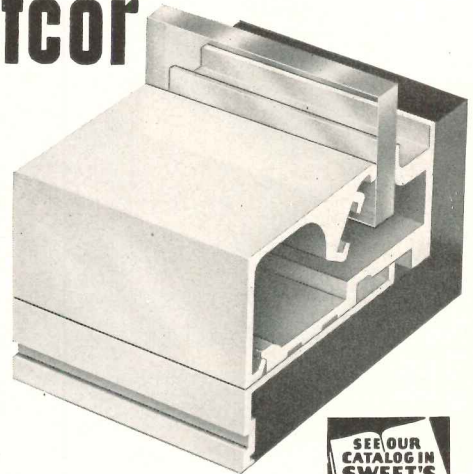

SEE OUR  
CATALOG IN  
SWEET'S

FOR DETAILS WRITE

## Latcor

**STORE  
FRONTS**  
PROVIDENCE 9  
RHODE ISLAND

### Month after Month— OZALID materials are UNIFORM!

They are constant in printing speed, in reprint speed, in image color and image density, and in dozens of other characteristics which give peak efficiency to an Ozalid operation.

This uniformity means that the Ozalid operator's time is spent in feeding material into the machine, rather than testing, retesting . . . then starting all over!

Ozalid's continuous laboratory control comes free with every package of Ozalid materials! And—Ozalid's nationwide technical organization is ready to help you in any part of the country.

#### Note to Non-Users of Ozalid:

Know the story of America's Simplest Business System. Ask for FREE booklet outlining the many ways in which Ozalid can save you time and dollars. Consult your classified directory or write to:



#### OZALID

Johnson City, N. Y., Dept. 87  
A Division of  
General Aniline & Film Corporation  
"From Research to Reality"

**DON'T COPY! . . . USE OZALID!**

# NEW HOLOPHANE CONTROLENS\* Completely ELIMINATES *GLARE* from FLUORESCENT LIGHTING

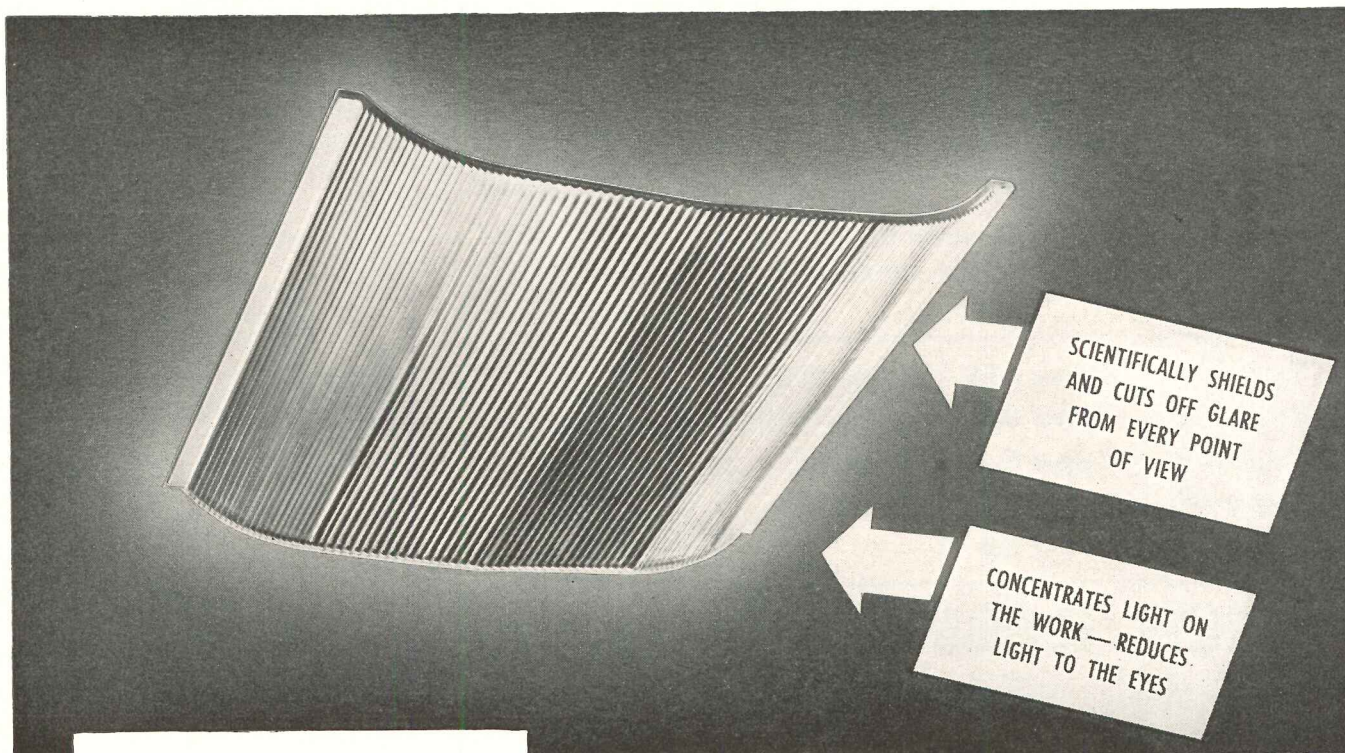

## NEW LENGTHWISE CONTROL

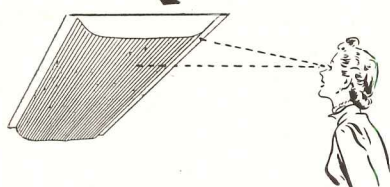

## AS WELL AS CROSSWISE CONTROL



**CUTS OFF  
GLARE  
COMPLETELY**



This new CONTROLENS, is as attractive in appearance as it is highly efficient in performance. It adds a note of elegance to a lighted interior, and provides optimum visibility with comfort. Its new optical construction solves the glare problem. Light that would normally appear in the glare zone is routed to the work. Some light goes directly to the ceiling to reduce contrast between lens and background. This lens is remarkably light in weight without loss of strength or resistance to breakage. Precision-sawed to insure a close fit to adjacent lenses. There is no transverse flange to detract from the unbroken streamlined appearance of continuous runs.

*Write for data on the new Holophane CONTROLENS today.*



\*REG. U. S. PAT. OFF.

## HOLOPHANE COMPANY, Inc.

Lighting Authorities Since 1898 • 342 MADISON AVENUE, NEW YORK 17, N.Y.  
THE HOLOPHANE COMPANY, LTD., THE QUEENSWAY, TORONTO 14, ONTARIO

# AMERICA'S MOST COMPLETE LINE OF CONVECTOR- RADIATORS

NOW... Fedders makes Convector-Radiators in America's most *complete* range of types and sizes as follows:

<b>Type F</b>	<b>Type SFB</b>	<b>Type RC</b>
<b>Type FE</b>	<b>Type W</b>	<b>Type RCB</b>
<b>Type FB</b>	<b>Type S</b>	<b>Type P</b>
<b>Type SF</b>	<b>Type R</b>	<b>Type PB</b>
	<b>Type RB</b>	

## QUICK RESPONSE

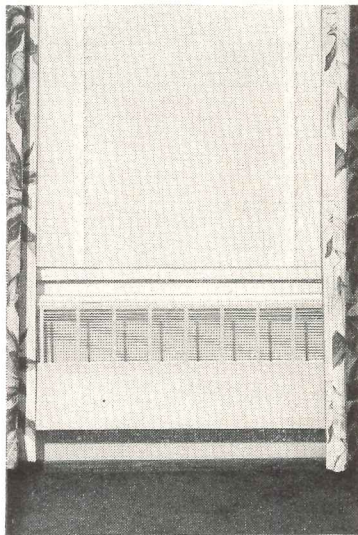

to manual and thermostatic control is an important reason for using Fedders Convector-Radiators. They are equipped with heating elements using copper tubes and aluminum fins,—the most efficient commercial heat transfer metals.

By reducing time lag, Fedders Convector-Radiators provide quick control and more uniform temperature, greater comfort and increased fuel economy.

*Write for Complete Information*

**FEDDERS-QUIGAN CORPORATION**  
BUFFALO 7, N. Y.

*A Great Name Since 1896*

**fedders**

## EMPLOYMENT OPPORTUNITIES AVAILABLE

*Advertising rates on request*

### Positions Open

**SEVERAL INSTRUCTORS:** In Architectural Design and related courses will be needed at schools of architecture. Those interested in a career in the teaching profession should apply to Professor Paul Weigel, Chairman of the Committee on Employment for the Association of Collegiate Schools of Architecture, Kansas State College, Manhattan, Kansas.

**PROGRESSIVE LONG ESTABLISHED OFFICE:** whose practice includes educational, hospital, church, and commercial work has immediate need for experienced architect or senior architectural draftsman, age around 35 to 45. Permanent position opportunity. State education, experience record, availability, salary and family status. Jameson & Harrison, Madison Theater Building, Peoria, Illinois.

**WANTED:** Good architectural designer-draftsman, someone who has had several years' experience in good offices after graduation from college. Position to be in one of the larger southern offices. Submit samples of recent work and give full particulars as to education and experience, with monthly salary desired. All replies will be treated strictly confidential. Box 416, *Architectural Record*, 119 W. 40th St., New York 18.

**ARCHITECTURAL DRAFTSMEN:** Experienced in working drawings and details with firm specializing in school design in several states. Please state training and salary expected. Warren S. Holmes Company, Architects, 2200 Olds Tower, Lansing, Michigan.

**ARCHITECTURAL DRAFTSMAN:** Thoroughly capable to prepare working drawings of schools, churches and commercial buildings. Good opportunity in small organization for right man. Phone 7384 or write 825 Jefferson Building, Greensboro, N. C.

**WANTED:** Architectural designer, renderer, by long established firm in Great Lakes Area. Contemporary designer with background and understanding of historical architecture. University Graduate. Possible teaching opportunity in School of Architecture. State age, experience, salary expected and availability. Box 417, *Architectural Record*, 119 W. 40th St., New York 18.

**ARCHITECTURAL DESIGNER:** Registered or Qualified for Registration. Institutional and commercial work. Associate status to right man. Applications solicited from Southeast Section. Reply fully to P. O. Box 2192, Atlanta 1, Ga.

**WANTED:** A good, experienced, architectural draftsman for long-established small office engaged in general practice. Permanent position for right man looking for place to settle and make his home. Non-industrial, cultured community of 50,000 with two 4-year universities — Illinois Wesleyan and Illinois State Normal. Address: Schaeffer, Hooton & Wilson, Architects, Peoples Bank Building, Bloomington, Illinois.

**WANTED:** Three top Architectural draftsmen, experienced in working drawings and details for hotels, resort and residential work. State education, experience record, availability and salary desired. Forward samples of work and photo. Hutchings & Milani, Architects, Engineers & Constructors, P. O. Box 485, Hamilton, Bermuda.

**WANTED:** Experienced architectural draftsman-detailer to complete working drawings from sketches Schools, hospitals, public buildings. This job is permanent and with excellent pay plus profit sharing. Well established North Carolina office. Give full particulars experience, samples, salary first reply. Box 418, *Architectural Record*, 119 W. 40th St., New York 18.

*(Continued on page 234)*



**Gain the Equivalent  
of an extra office**

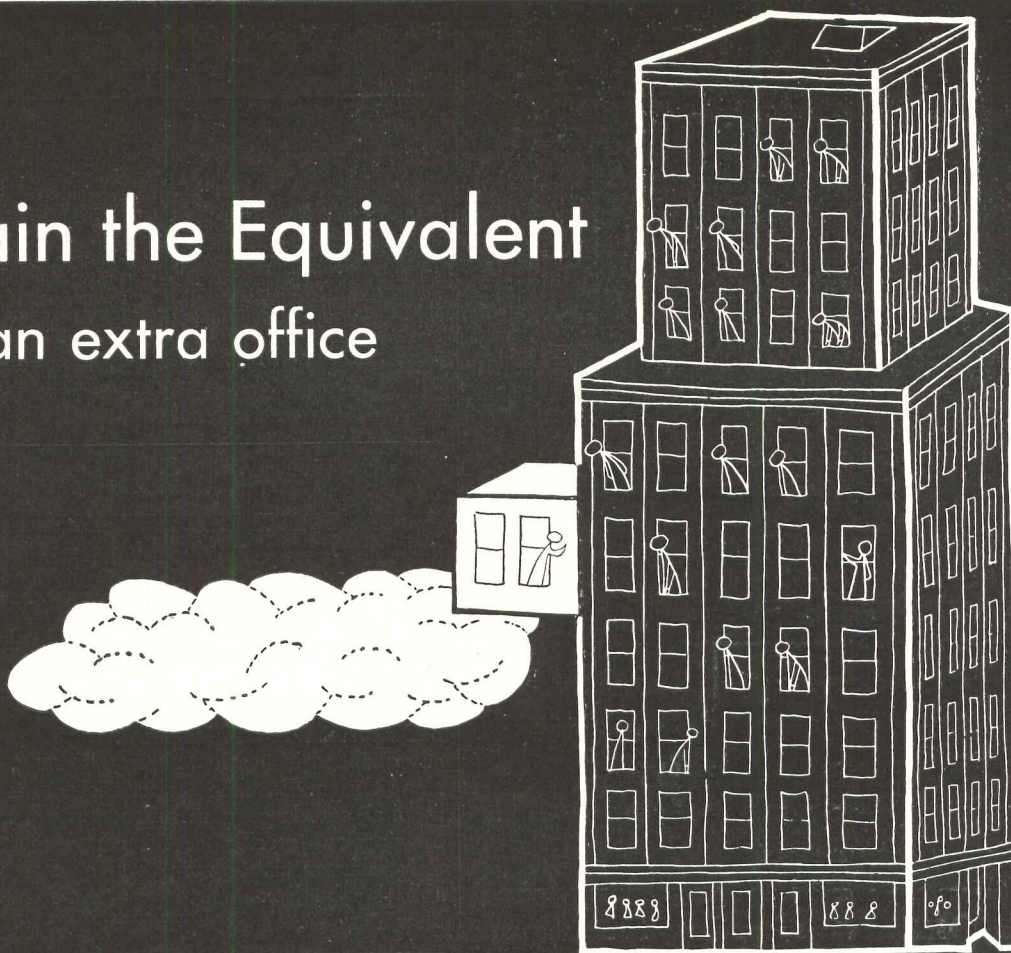

**Specify**

## **2" Solid ROCKLATH\* and Plaster Partitions**

If you have a fairly large office building you may be able to gain usable, rentable space on every floor roughly equivalent to the addition of an extra suite of offices. On a smaller scale, you can have enough additional room to accommodate an extra typewriter desk or filing cabinet in every 20 by 20-foot office.

How? By specifying 2-inch Solid ROCKLATH and Plaster Partitions! You'll gain three inches of space along the full length of the partition, compared with a conventional partition five inches thick when plastered.

You'll gain extra safety, too—because 2-inch Solid ROCKLATH and Plaster Partitions, properly plastered, have a one-hour fire endurance rating. They have abundant strength, yet weigh only 16 pounds per square foot, installed. They cost no more, installed, than conventional partitions, and often cost less.

When you plan to build and when you replace old partitions, investigate this important USG development. Ask your USG representative for the complete story next time you see him.

\*T. M. Reg. U. S. Pat. Off. It distinguishes the United States Gypsum Company's plaster base.



**United States Gypsum**

**For Building • For Industry**

Gypsum • Lime • Steel • Insulation • Roofing • Paint

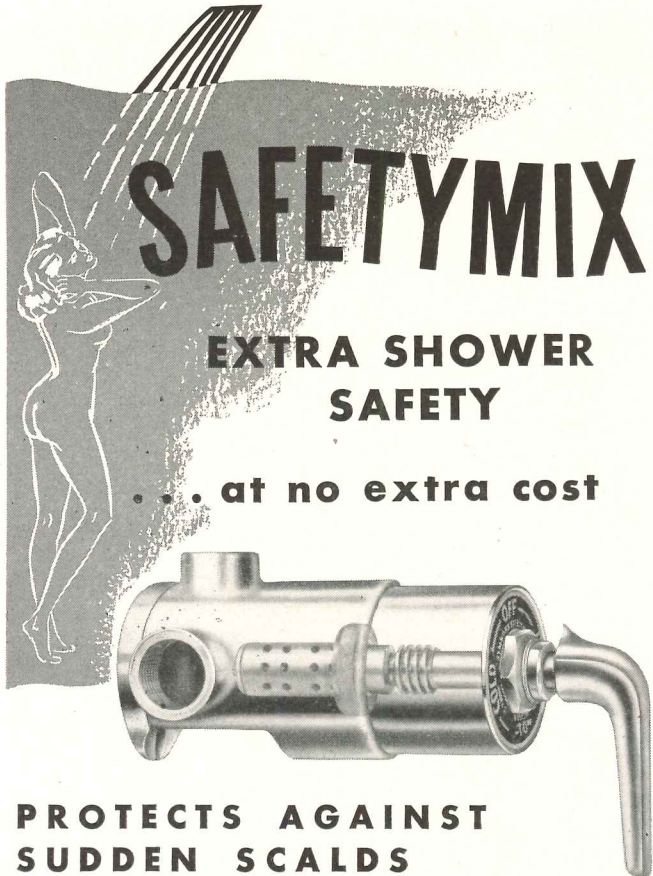

**PROTECTS AGAINST SUDDEN SCALDS**

... Safetymix, world's leading pressure-actuated non-scald shower valve gives safety in the shower. Safetymix automatically shuts down flow if either hot or cold water fails.

**HOLDS SHOWER TEMPERATURE CONSTANT**

... Even with excessive pressure fluctuations up to 85%, Safetymix still maintains constant discharge temperature.

**LIFETIME SHOWER VALVE**

... The most rugged shower control valve made. Only Safetymix has the patented Flow Control Spindle with but one moving part to control all valve functions. Built to last a lifetime.

**GET FREEDOM FROM COSTLY MAINTENANCE**

... Safetymix is designed with self-cleaning action to prevent clogging and save water. All parts accessible from the front. As easy to fix as a faucet.

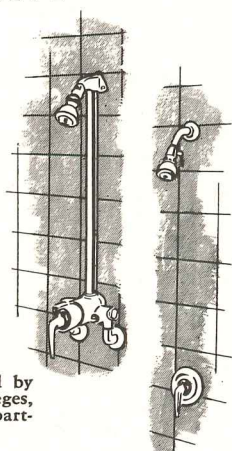

100,000 Installations Can't Be Wrong. Used by U. S. Army, Navy, Merchant Marine, colleges, industrial plants, hotels, clubs, hospitals, apartments and homes.

Send for bulletin and prices.

**SAFETYMIX—MADE BY THE MAKERS OF THE NEW SYMMONS TEMPERING-CONTROLLER**

**Symmons ENGINEERING COMPANY**  
791 TREMONT ST., BOSTON 18, MASS.

**EMPLOYMENT OPPORTUNITIES AVAILABLE**

*Advertising rates on request*

*(Continued from page 232)*

**Position Open**

**DRAFTSMAN:** With at least twelve years architectural experience for 35-hour week on N.Y.C. major oil company service station, bulk plant and terminal work. Opportunity for permanency and advancement. Give particulars on age, education, registration status, references, salary and experience in checking, specification writing, supervising draftsmen and business consultations. Box 421, *Architectural Record*, 119 W. 40th St., New York 18.

**Positions Sought**

**CHICAGO ARCHITECT-DESIGNER AND ARTIST:** With office force, interested in design consulting assignments and associating on projects. Has engaged in design and editorial work with nation-wide organizations and magazines. Excellent training and experience in design, delineation and article-writing. Box 419, *Architectural Record*, 119 W. 40th St., New York 18.

**MECHANICAL ENGINEER:** 20 years experience, exceptionally qualified in heating, air conditioning, plumbing and boiler plant design. Excellent experience on commercial, industrial, hospital and large government projects. Ability to produce drawings and specifications to a high professional standard. Interested in association with progressive architectural firm. Available shortly. Box 420, *Architectural Record*, 119 W. 40th St., New York 18.

**PREFABRICATION IN BUILDING**

By **RICHARD SHEPPARD, F.R.I.B.A.**

This book examines the development of prefabrication in England, America and elsewhere, and analyzes in detail the various systems — some commercial and some merely experimental — which have so far been used. It considers the important relationship between prefabrication and the industrial and economic background in various countries and outlines the changes that prefabrication is bringing about in building procedure.

No builder or architect who is seeking ways to economize on house construction can afford to miss this valuable guide — 148 pages printed in large clear type on heavy coated paper, well indexed and illustrated with 163 excellent photographs and diagrams. \$5.50 per copy.

Book Department, **ARCHITECTURAL RECORD**  
119 West 40th Street, New York 18, N. Y.

I enclose \$..... Send me..... copy(s) of "PREFABRICATION IN BUILDING," by Richard Sheppard at \$5.50 per copy. (Add 2% Sales Tax for New York City delivery — \$5.61 in all)

Name.....

Address.....

City..... Zone..... State.....

**Do your  
clients still think  
automatic heat is a  
LUXURY ITEM?**

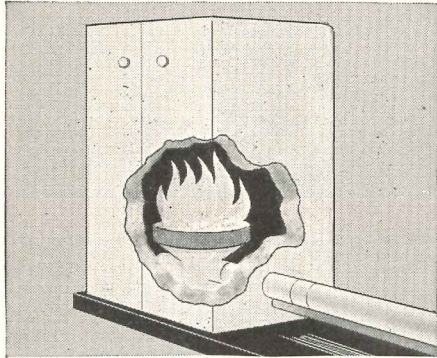

**Automatic Anthracite Stokers**—Installed in an existing boiler or furnace and in new houses, automatic hard coal stokers deliver *plenty* of heat quickly . . . save up to 52% on fuel bills . . . eliminate fuel worries.

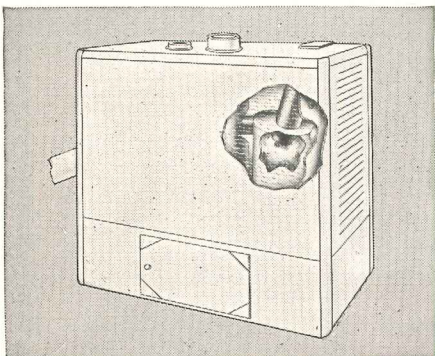

**The Revolutionary Anthratube**—The Anthratube saves on fuel bills . . . its proved efficiency is over 80%. This scientifically engineered boiler-burner unit, with "Whirling Heat" and other revolutionary features, produces quicker response and superior performance than units using other types of fuel.

**Automatic Anthracite Heat offers  
savings up to 52% on annual fuel bills**

● Here's how you can be a real friend to your customers . . . and build good will plus future business for yourself.

Explain to them that completely automatic heat, with modern anthracite equipment, is *not* a luxury.

Tell them how modern automatic equipment burns the cheaper sizes of Anthracite . . . pays for itself in a few years . . . saves money after that.

You'll find that most people will welcome the chance to save \$100 to \$200 every year . . . particularly when they learn they can have all the comfort and convenience of completely automatic heat. Moreover, you can assure them they will have *plenty* of heat . . . because there's plenty of hard coal now, and for years to come.

Get complete information by writing to Anthracite Institute *now*.



**ANTHRACITE INSTITUTE**

101 Park Avenue

New York 17, New York

ANTHRACITE INSTITUTE  
101 Park Avenue, Dept. 6B  
New York 17, New York

Please send me more information on anthracite and anthracite equipment.

Name \_\_\_\_\_

Address \_\_\_\_\_

City \_\_\_\_\_ Zone \_\_\_\_\_ State \_\_\_\_\_

PLEASE PRINT

# NOW

# LAWSON

## BATHROOM CABINETS

# BONDERIZED

## AFTER FORMING!

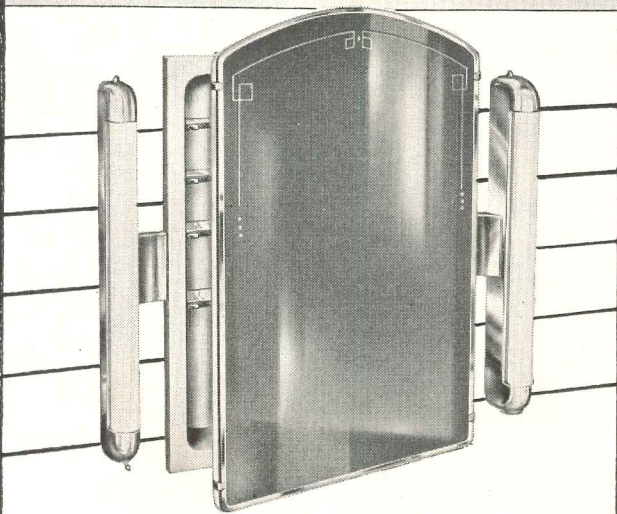

BONDERIZED AFTER FORMING is an important new feature added to all Lawson Bathroom Cabinets! The bonderizing process is applied AFTER all shearing, drilling and forming is completed. It provides 100% BONDERIZED protection against rust and corrosion . . . assures longer life for all Lawson Cabinets!

AND . . . Lawson Cabinets, BONDERIZED AFTER FORMING, cost no more!

ARCHITECTS SPECIFY  
LAWSON BATHROOM CABINETS . . .

BECAUSE they have:  
*one-piece drawn steel body, stainless steel hinge and shelf supports, first-quality mirror . . . and now, they are BONDERIZED AFTER FORMING!*

Write today for catalog of bathroom cabinets and chrome accessories.

WORLD'S LARGEST BUILDERS  
OF BATHROOM CABINETS

THE F. H. LAWSON CO.

824 EVANS ST.,

...

CINCINNATI 4, O.

Lawson  
BATHROOM  
CABINETS

133 YEARS



Reg. U. S. Pat. Off.

Are you specifying  
the **RIGHT CEMENT**  
FOR THE JOB?

### MEDUSA "JOB-FITTED" CEMENTS

- MEDUSA WATERPROOFED GRAY**  
Produces concrete that repels water at the surface.
- MEDUSA WHITE**  
Gives a beautiful white or colorful tinted effect. Widely used for stucco.
- MEDUSA WATERPROOFED WHITE**  
Unsurpassed for a sparkling white water-resisting surface.
- MEDUSA BRIKSET**  
Gives a beautiful finish for brick mortar.
- MEDUSA "MEDCO" HIGH EARLY STRENGTH**  
Prepared for rush jobs and cold weather construction.
- MEDUSA AIR-ENTRAINING PORTLAND CEMENT**  
Protects driveways and sidewalks against the scaling action of salt.
- MEDUSA STONESET**  
A non-staining waterproofed cement for laying up stone and face brick.

For further information on any of these cements, simply check this ad, attach to your business letterhead and mail to us.

# MEDUSA

## PORTLAND CEMENT CO.

1015 Midland Bldg. • Cleveland 15, Ohio

FIFTY-SEVEN YEARS OF CONCRETE PROGRESS

10 INCHES

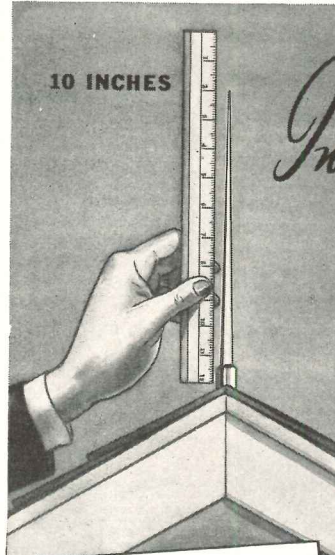

*Inconspicuous*  
**LIGHTNING  
PROTECTION**

The West Dodd System of Lightning Protection is inconspicuous. Leaves nothing to mar the architectural beauty of any building. When installed by factory trained experts it provides almost 100% protection from lightning. West Dodd Systems are fully approved by all authorities, including Underwriters' Laboratories and American Institute of Electrical Engineers.

**FREE** estimating and engineering service to architects on request. Write for complete information.

Adds to the safety of  
Suburban residences  
.. Churches .. Schools  
.. Power plant stacks  
.. Farm buildings



# WEST DODD

LIGHTNING CONDUCTOR CORP.  
Goshen, Indiana

# REDUCE WATER COSTS with SPEAKMAN ANYSTREAM SHOWER HEADS

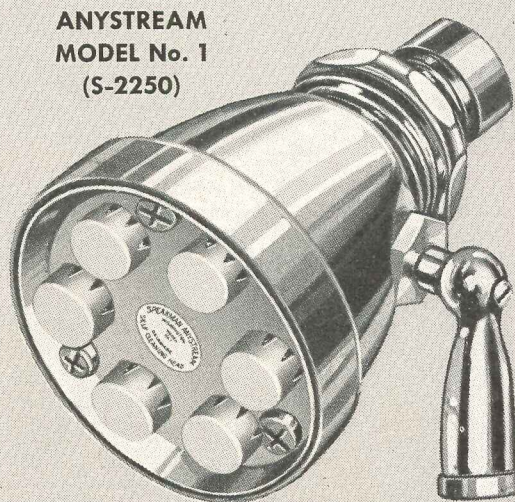
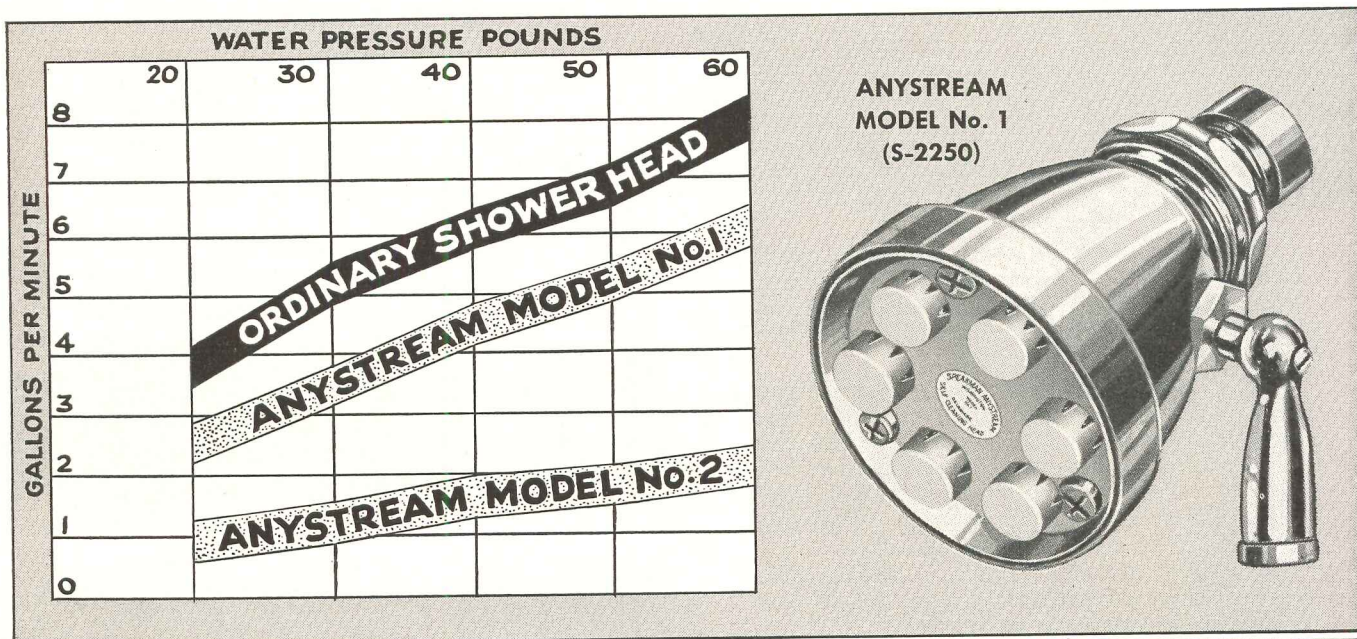

**S**PEAKMAN ANYSTREAM SHOWER HEADS reduce water consumption—hot water usage—water bills by as much as 58% over ordinary shower heads.

SPEAKMAN ANYSTREAM SHOWER HEADS give the world's best showers . . . full-pattern, free-flowing, completely adjustable spray at all times—even at low pressures.

Maintenance costs are important, too! SPEAKMAN ANYSTREAM SHOWER HEADS are built to give years of trouble-free service. There's nothing to get out of order—no tiny, pin-point holes that can become clogged. They are completely self-cleaning! No SPEAKMAN Showers or Fixtures will ever become obsolete. Repair parts, if needed, will always be available.

Write today for our booklet S-54 that contains specifications and illustrations of SPEAKMAN Showers and Fixtures.



A turn of the lever gives Needle Spray for stimulation



Normal Spray for Relaxation



Flood Spray for non-splash rinse

ANYSTREAM  
MODEL No. 2  
(S-2250)



In Our Eightieth Year  
**SPEAKMAN**

SHOWERS AND FIXTURES

SPEAKMAN COMPANY, WILMINGTON, DELAWARE



EXPOSED SENTINEL SHOWER  
(S-1720)

with Anystream Shower Head and Sentinel Balanced Pressure Shower Mixing Valve.

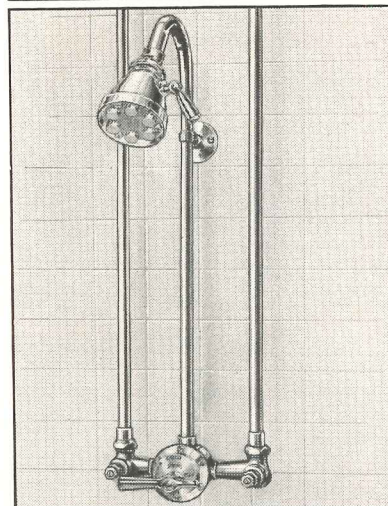

**SPEED**  
inefficiency out  
through your roofs  
with  
**Swartwout**  
**VENTILATORS**

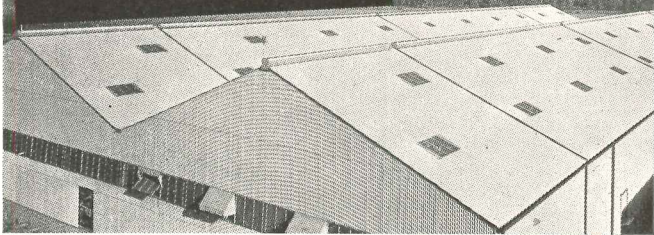

You can frequently trace accidents, work spoilage and low production to insufficient ventilation. A large proportion of these problems in industrial buildings can be solved with gravity-type roof ventilators.

Swartwout-Dexter Heat Valve (above) and AIRMOVER (top right) are two of the most successful systems of this type. Scientifically designed to permit upward movement of hot air, smoke and fumes with least resistance, their construction also takes advantage of outside air movement and wind suction effect.

Weatherproof at all times . . . they can be closed when desired. Swartwout Ventilators are used on thousands of factories, foundries, warehouses, etc.

Write for complete ventilator catalog.

**The Swartwout Company**  
18639 Euclid Avenue • Cleveland 12, Ohio

Use Ject-O-Valve for fast power ventilation of "Hot Spots"

Speeds heat and bad air up through roofs with powerful force. Always weatherproof. Patent applied for.



**Swartwout**  
*Controlled* Air Circulation

EQUIPMENT FOR EFFECTIVE ECONOMICAL VENTILATION OF INDUSTRIAL BUILDINGS

**MORE APPEAL IN YOUR HOMES**  
with **MODERNFOLD DOORS**

WHERE CLOSURE PROBLEMS ARE TRICKY, employ Modernfold magic. It simplifies closing off Pullman kitchens, bedrooms, alcoves, etc.



AS A "MOVABLE" WALL Modernfold can be used to divide a large room into small private rooms.



TO SAVE SPACE for all types of interior openings — approximately 8 sq. ft. of space — space swinging doors waste.



Modernfold Doors are accordion-like in opening and closing . . . add sparkle with their beautiful, washable fabric covering . . . are rigid and strong—thanks to a sturdy metal frame. Write for full details.

**modernfold**  
DOORS

**NEW CASTLE PRODUCTS**

New Castle Indiana

In Canada: Raymond Mfg. Co., Ltd., Montreal

Consult your local telephone book for the names of our Installing Distributors

**Insist**  
**on this**  
**Seal...**

when you specify  
**ALUMINUM**  
**WINDOWS**

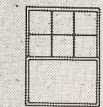

DOUBLE-HUNG

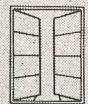

CASEMENT



PROJECTED

This seal assures windows that, when tested by the independent Pittsburgh Testing Laboratory, meet the A.W.M.A. quality specifications for materials, construction, strength of sections, and minimum air infiltration requirements.

For complete specs covering "Quality-Approved" aluminum windows—double-hung, casement and projected—and names of approved manufacturers, consult Sweet's or write to the address below, Dept. R.

ALUMINUM WINDOW MANUFACTURERS ASSOCIATION  
209 Cedar Avenue, Takoma Park, Washington 12, D. C.

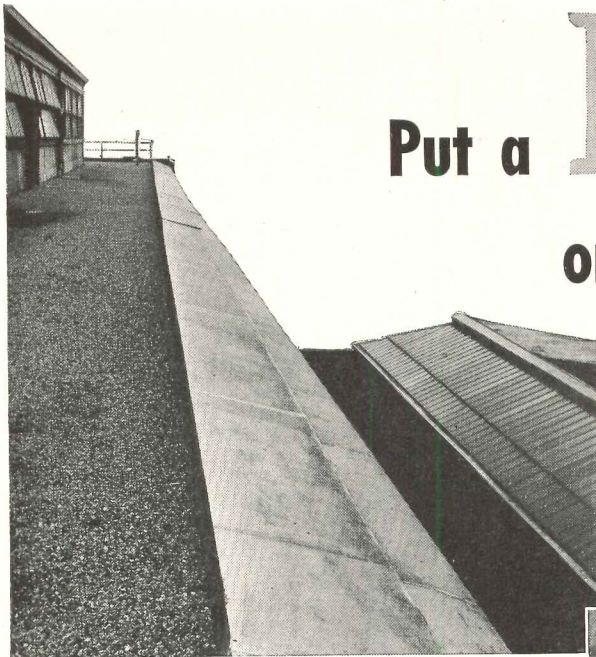

MONEL PARAPET FLASHING, sidings, skylight trim and gutters. Installed on a coal-burning power plant in 1913, they are still in good condition.

# Put a ROOF on the rising cost of Upkeep!

*Roof upkeep doesn't have to be a constant expense. Architects can end this problem with economical Monel Roofing Sheet—roofing that lasts the life of the building*

There's one simple way to assure your clients long-lasting, trouble-free roofing.

**Give them roofs of MONEL\*.**

Monel is a non-rusting alloy consisting of approximately  $\frac{2}{3}$  nickel and  $\frac{1}{3}$  copper. Throughout industry it is known for its resistance to:

- corrosion
- severe stresses
- wear and abrasion
- buckling and cracking

Monel is doing hundreds of different jobs — tough jobs — in many fields, in many forms.

To you, it offers an opportunity to help clients reduce annual outlays for roof maintenance. A quick look at the record will prove that. Monel roofing installations date back to 1910 and they are still in good condition today.

No wonder Monel is called "life-of-the-building" roofing!

**Investigate the practical** advantages of Monel Roofing Sheet for the building now on your boards. Remember, the term "Monel Roofing" includes not only entire roofs, but also roofing parts such as flashings, skylight frames, ventilators, louvers, gutters, siding, expansion joints and copings.

**Roofers' quotations** on Monel installations are comparable to those on other quality materials. Monel's excellent properties permit use of lighter gauge sheet on practically every job.

**WRITE FOR NEW BULLETIN**

You'll find a complete review of the properties and characteristics of this economical roofing metal in our new bulletin, *Basic Application Data — Monel Roofing Sheet*. In addition to indicating how you can save your clients money by reducing gauges, the bulletin gives information about availability, discusses installation procedures, and provides a sample specification wording.

SEND FOR YOUR COPY of this helpful, file-size bulletin now. The coupon will bring it to you promptly and without obligation.

**THE INTERNATIONAL NICKEL COMPANY, INC.**

\*Reg. U. S. Pat. Off.

67 Wall Street, New York 5, N. Y.

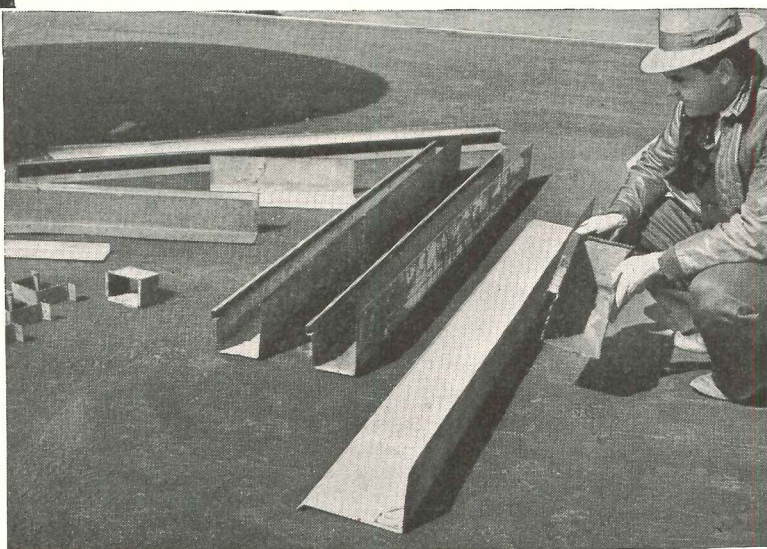

INSTALLED ON A chemical manufacturing plant, these Monel gutters, base, cap and step flashings, down spout straps and eaves boxes are successfully resisting destructive fumes, smoke and lowland dampness.

## MONEL ROOFING

For the "Life-of-the-Building"

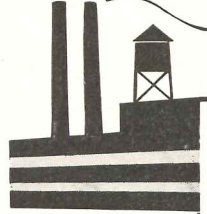

GET VALUABLE REFERENCE BULLETIN

Architectural Section  
The International Nickel Company, Inc.  
67 Wall Street, New York 5, N. Y.

Please send me without obligation a copy of your new bulletin for architects, *Basic Application Data — Monel Roofing Sheet*.

Name.....  
Firm.....  
Address.....  
City.....Zone.....State.....

AR-6-49



# CINCO

*Sto-a-way*

## ALUMINUM COMBINATION SCREEN AND STORM SASH



*Offer* THE COMFORT, CONVENIENCE, PROTECTION YOUR CLIENTS LIKE... SELF-STORAGE . . . YEAR 'ROUND, RAINPROOF, DRAFT-FREE, FILTERED-SCREEN VENTILATION . . . PATENTED THERMOLOK\* CLOSURE FRAME and other advantages that add livability to a home.

One of the products of the F. C. Russell Company . . . all of which are self-liquidating investments in comfort, convenience and safety

A nationwide network of competent, reliable distributors and a staff of experienced field engineers give assurance that The F. C. Russell Company products you specify will be installed in accordance with your specifications. These same distributors and field engineers are at your service to give you the benefit of their wide experience with problems of installation and protection for all types of windows—for homes, commercial buildings, institutions.

The F. C. Russell Company line of combination windows offers a wide choice of designs to fit specific requirements . . . steel, aluminum, wood . . . all properly treated for weather resistance.

Consult Sweet's Catalog, your local Russell Distributor, or write direct for complete details and specifications on all The F. C. Russell Company products.

### OTHER F. C. RUSSELL COMPANY PRODUCTS

- RUSCO all-metal, self-storing combination window.
- THERMOSEAL aluminum self-storing combination window.
- THERMOSEAL three-in-one combination window.

ALUMINUM CASEMENT STORM SASH . . . RUSCO ALL-METAL, VENETIAN-TYPE AWNINGS . . . RUSCO ALL-METAL JALOUSIES . . . RUSCO ALL-METAL TERRACE AWNINGS . . . RUSCO ALL-METAL DOOR CANOPIES . . . CINCINNATI CUSTOM-BUILT INSECT SCREENS . . . DUO-GLAZE INSULATION . . . RUSSELL PATENTED "CUSHION-SEAL METHOD" OF GLAZING THERMOPANE.

## The Cincinnati Fly Screen Division

of THE F. C. RUSSELL COMPANY  
DEPARTMENT 3-AR69, CLEVELAND 1, OHIO

World's Largest Manufacturer of Combination Windows

© TFCRC

\*T. M. REG. APP. FOR



*Available Now!*

**CHENEY  
FLASHING**

*3-Way Bond*

16 OZ. COPPER

**CHENEY  
FLASHING  
REGLET**

16 OZ. COPPER

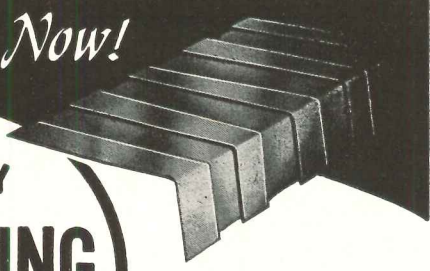

CHENEY FLASHING is again being made by the original inventor who pioneered the art of thru-wall flashing eighteen years ago.

No thru-wall flashing can operate successfully unless it has the two very important features that are found in CHENEY FLASHING—proven weep-hole drainage and the three-way bond, vertical as well as longitudinal and lateral.

Remember, the inferior two-way flashings, crimped copper and membranes, have neither the vertical bond nor do they drain moisture from the wall fast enough. Furthermore, their first cost advantage has disappeared because today Cheney Flashing is no longer a specialty—it's a standard commodity.

WRITE FOR  
DESCRIPTIVE FOLDER Dept. R

**CHENEY FLASHING CO. Trenton, N. J.**

*Recognized Everywhere!*



- Best Materials
- Finest Workmanship
- Trouble-free Valves and Fittings
- Complete Sanitation

Specify HAWS—and be sure!

**IT'S HAWS FOR  
HIGHEST QUALITY**

Write today for '49 HAWS Catalog.

**HAWS** SANITARY DRINKING FOUNTAINS  
ELECTRIC WATER COOLERS

**HAWS DRINKING FAUCET CO.**

1441 FOURTH STREET (Since 1909) BERKELEY 10, CALIFORNIA

Agents and Sales Representatives in All Principal Cities



# NO GAMBLING WITH QUALITY...



11,000 feet of Revere Copper Water Tube were used in the radiant panel heating system. The building has 9 zones, with each room controlled by individual thermostats. Revere Copper Water Tube was also used for hot and cold water lines, and Revere Sheet Copper for roofing.

## ...as the Manager of Reno's famed Harold's Club Builds a Magnificent New Home

IT'S always a safe bet—for radiant panel heating as well as for hot and cold water lines—that Revere Copper Water Tube will provide many long years of continuous service. This tube guards against leaks, rusty tap water, inadequate flow and faulty circulation. Yet, completely installed it costs little or no more in the first place . . . and may be much less in the long run.

All Revere Copper Water Tube is stamped at regular intervals with the Revere name and the type. These marks are more than identification—they are your assurance of full wall thickness and the close dimensional tolerances so essential for tight soldered joints.

Other Revere products include: Copper Water Tube for use with soldered fittings for hot and cold water lines and heating lines; Red-Brass Pipe; Sheet Copper and Herculoy for tanks, pans, ducts and trays; Panel Sheets in architectural bronze, nickel silver and copper; Extruded Shapes in architectural bronze, nickel silver and

aluminum . . . and, of course, Sheet Copper for roofing, flashing and other sheet metal construction. They are handled by leading distributors in all parts of the country.

Raymond I. Smith residence, Reno, Nevada.  
Architect: Gulling & Means; Plumbing, heating and sheet metal contractor: Charles Burke, Jr.; Revere Distributor: Acme Supply Co.—all of Reno, Nevada.

# REVERE

**COPPER AND BRASS INCORPORATED**

*Founded by Paul Revere in 1801*

230 Park Avenue, New York 17, New York

Mills: Baltimore, Md.; Chicago, Ill.; Detroit, Mich.;  
Los Angeles and Riverside, Calif.; New Bedford,  
Mass.; Rome, N. Y.—Sales Offices in Principal Cities,  
Distributors Everywhere.



Ask the  
**AEROFIN** Man  
to Help You on Your  
Cooling or Heating Problems

Aerofin Corporation, through its home office and nine strategically located branch offices, is prepared to help you on all problems involving the application of Aerofin heat exchange surface or to suggest the most efficient use of this superior surface to a variety of requirements.

The prompt, personal and technical cooperation of our engineers is at your disposal. Write to the home office in Syracuse or consult your local telephone directory for addresses of branch offices listed.

Aerofin is sold only by manufacturers of nationally advertised fan system apparatus.  
List on request.

## AEROFIN Heat Exchange Surface

# AEROFIN CORPORATION

410 South Geddes St. SYRACUSE 1, N. Y.

NEW YORK • CHICAGO • CLEVELAND • DETROIT • PHILADELPHIA • DALLAS • SAN FRANCISCO • TORONTO • MONTREAL

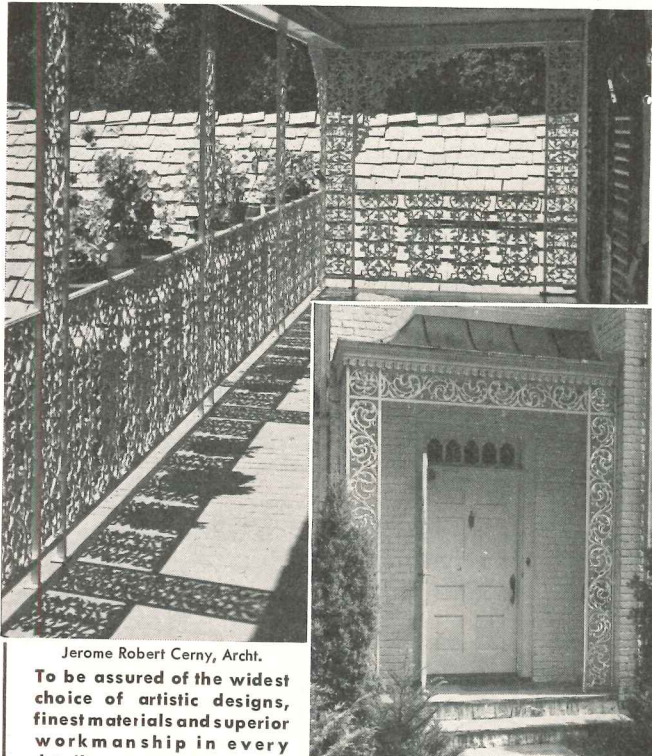

Jerome Robert Cerny, Archt.  
To be assured of the widest choice of artistic designs, finest materials and superior workmanship in every detail—

Paul W. Drake, Archt.

### Specify "Metal Work by FISKE"

Visit our show room display of Ornamental Iron Work: Verandas, Balconies, Railings, Entrances — or write for catalog.

## J. W. FISKE Iron Works

80 Park Place • Dept. 10 • New York 7, N. Y.  
ESTABLISHED 1858

# Schundler Vermiculite

## PLASTER AGGREGATE

**Reduce danger of destructive fires!** Schundler vermiculite is fireproof. One inch of vermiculite plaster has been given a 4-hour fire rating for steel beam protection. Save on weight — 3½ times the insulating value with only ⅓ the weight of sand plaster . . . Acoustical . . . Crack resistant . . .

## CONCRETE AGGREGATE

Use Schundler vermiculite for insulating concrete floor slabs in basementless houses. Direct the flow of heat in radiant floor panel installations by laying the pipes directly on the insulating concrete.

Used for roof fill, in light-weight structural roof, dairy barn floors and insulating walls. It is light-weight, fireproof, and eliminates condensation.

Write for descriptive literature on these Schundler Vermiculite Products.

## F. E. SCHUNDLER & CO., INC.

Joliet, Illinois  
505 Railroad St.

Long Island City, N. Y.  
46-16 Vernon Blvd.

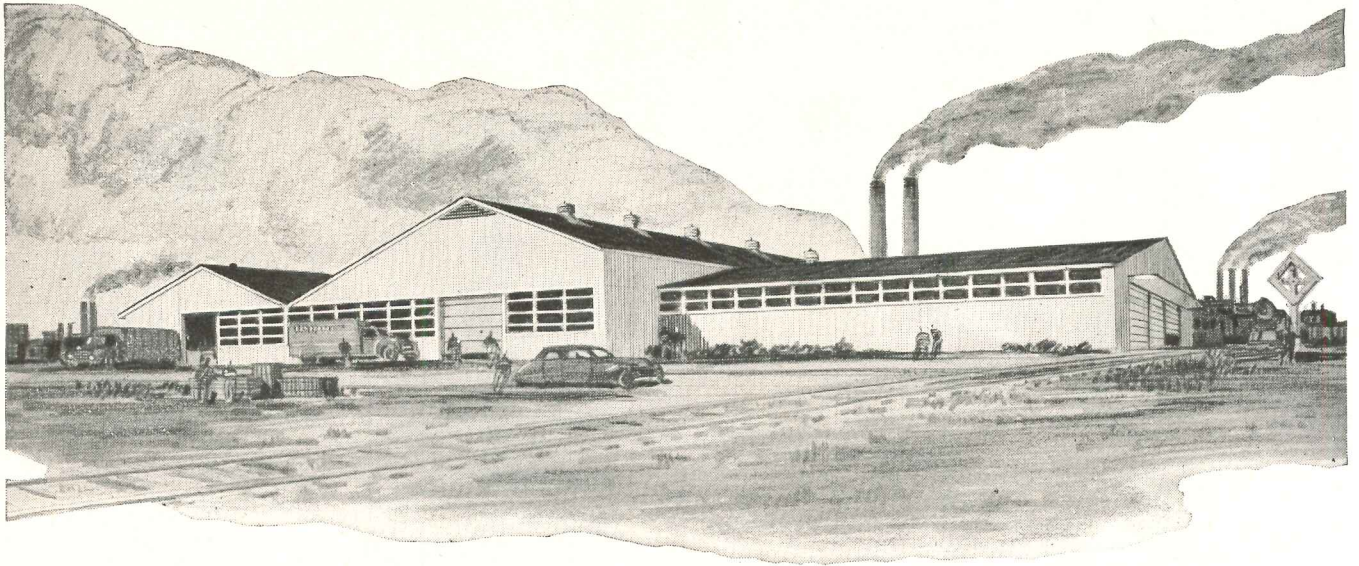

# Industry needs more low-cost plants like this!

*and the industrial architect can serve more clients  
— by planning new construction around STANDARD BUILDINGS by LURIA*

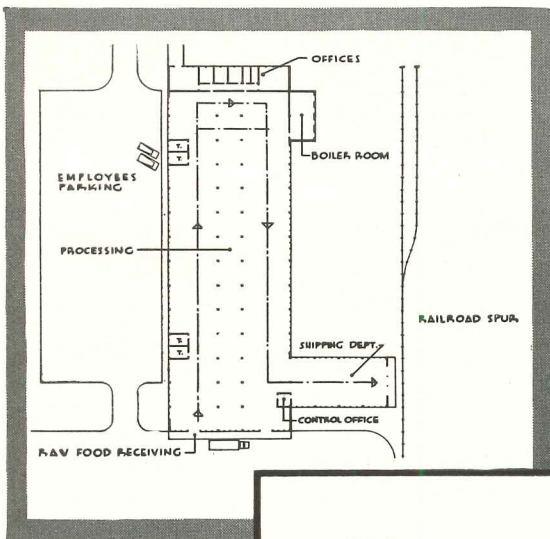

Plan of processing plant is designed around these four Luria units — all with 40-foot spans. The two large units, with eave heights of 12 and 20 feet, are joined by a 20-foot wide lean-to.

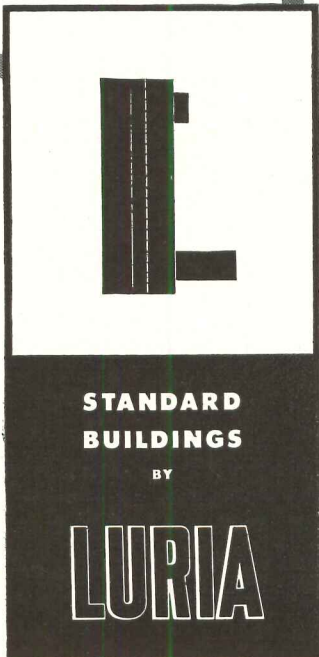

**STANDARD  
BUILDINGS**

BY

**LURIA**

*Luria buildings are available now*—with clear spans of 40 to 100 feet, eave heights of 12 to 20 feet and any desired length in increments of 20 feet.

Industrial housing needs are greater today than ever before. New industries want to build, old ones want to expand or decentralize. Nearly all are following the current trend to one-story buildings—and nearly all are faced with the problem of high building costs.

For a practical solution to this problem, more and more architects are designing around Standard Buildings by Luria. These *permanent*, one-story structures have saved many companies up to 30% on their building costs. Moreover, they are easy to erect, economical to maintain, and *available now!*

Far from limiting the imagination of the architect, Luria buildings actually create new opportunities for design, and widen the circle of his prospective clients. For here is a new and flexible medium to work with, offering the architect a wide choice of collateral materials, optional features and multiple arrangements.

And Luria buildings are by no means confined to industry. Shopping centers, schools, bus terminals, churches—these are just a few of the hundreds of applications where Luria buildings offer all the cost-saving advantages of standardization, yet give the widest possible architectural freedom. For information on the complete Luria line, send for our new, 20-page catalog.

**LURIA ENGINEERING CORPORATION, Dept. D30**  
500 Fifth Ave., New York 18, N. Y.

Gentlemen: Please send me a copy of your new catalog (AIA File 14i).

NAME.....

COMPANY.....

ADDRESS.....

CITY.....STATE.....

that  
finishing  
touch  
of  
charm...

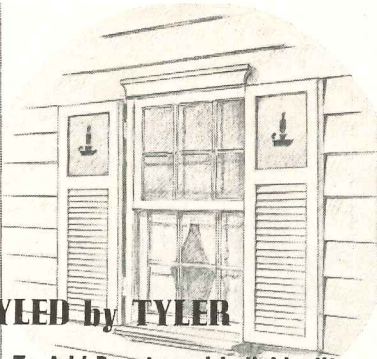

**STYLED by TYLER**

**To Add Beauty and Individuality  
to the Home.**

TYLER Blinds and Shutters lend added distinction to the home — in perfect tune with architecture — with harmony assured by the wide selection of attractive styles. Non-standard sizes and designs for special requirements will be custom-built.

For over seventy years builders and architects have specified TYLER shutters for styling, construction quality, and lasting value. Today, TYLER Shutters and Blinds are accepted everywhere as the best.

**Sold by Leading Lumber  
Dealers Everywhere.**

**ARTHUR F. TYLER CO.**

Established 1871

**900 MAIN ST. ATHOL, MASS.**

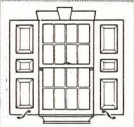

A note of individuality—novel stock cutouts to suit the personality or locale of the home. Designs and monograms to your sketches.

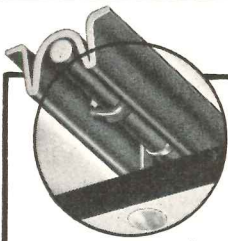

**SAFEST AND  
SIMPLEST METHOD**

The Naillock Method is the simplest and safest method of installing a suspended ceiling construction with or without acoustical tiles.

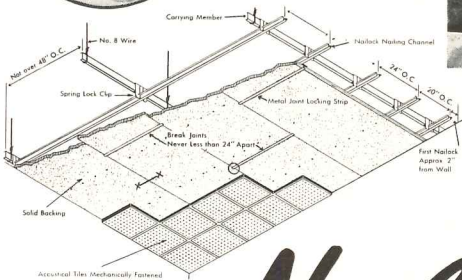

Nailing solid backing to Naillock Universal Nailing Channel assures rigidity, permanency and safety.

Use **Naillock**

**FOR SUSPENDED CEILING CONSTRUCTION**

Permits Use of Any Acoustical Materials Required

Reduce time-wasting grief and time cost on suspended ceiling jobs. Naillock Universal Nailing Channels provide a means for securely fasten-

ing backing or backer-board and acoustical tiles in place, and assure a rigid, safe and permanent suspended ceiling installation.

**NAILOCK STEEL DIVISION  
THE SANMETAL PRODUCTS CO., INC.**  
1689 Urbana Road • Cleveland 12, Ohio



**U. S. MAIL  
CHUTES**

are essential in progressive apartments and hotels.

This little Miss prefers to mail her own letters and so do her parents.

*This equipment may be leased  
if desired*

ESTABLISHED 1883

**Gutter Mail Chute Co**

ROCHESTER 7, N. Y.

**Completely  
UNDER CONTROL!**

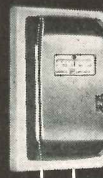

**THE NEW 500 M.V. B-60 COMPLETELY SELF-CONTAINED AND SELF-OPERATING CONTROL SYSTEM ORIGINATED BY**  
**General Controls**  
**★10 years of proven performance.**

For natural, manufactured or L.P. gases. For domestic, commercial and industrial applications. System consists of the B-60 pilot operated diaphragm type gas valve, the T-70 Series Snap-action Thermostat, which is scientifically correct in design, and the new improved ingenious PG-9 Pilot Generator which produces 450 to 500 millivolts of operating current, also safety control and main burner ignition.

FOR COMPLETE SPECIFICATIONS request new Catalog.

**GENERAL CONTROLS**  
801 ALLEN AVENUE GLENDALE 1, CALIF.  
FACTORY BRANCHES and DISTRIBUTORS  
IN PRINCIPAL CITIES

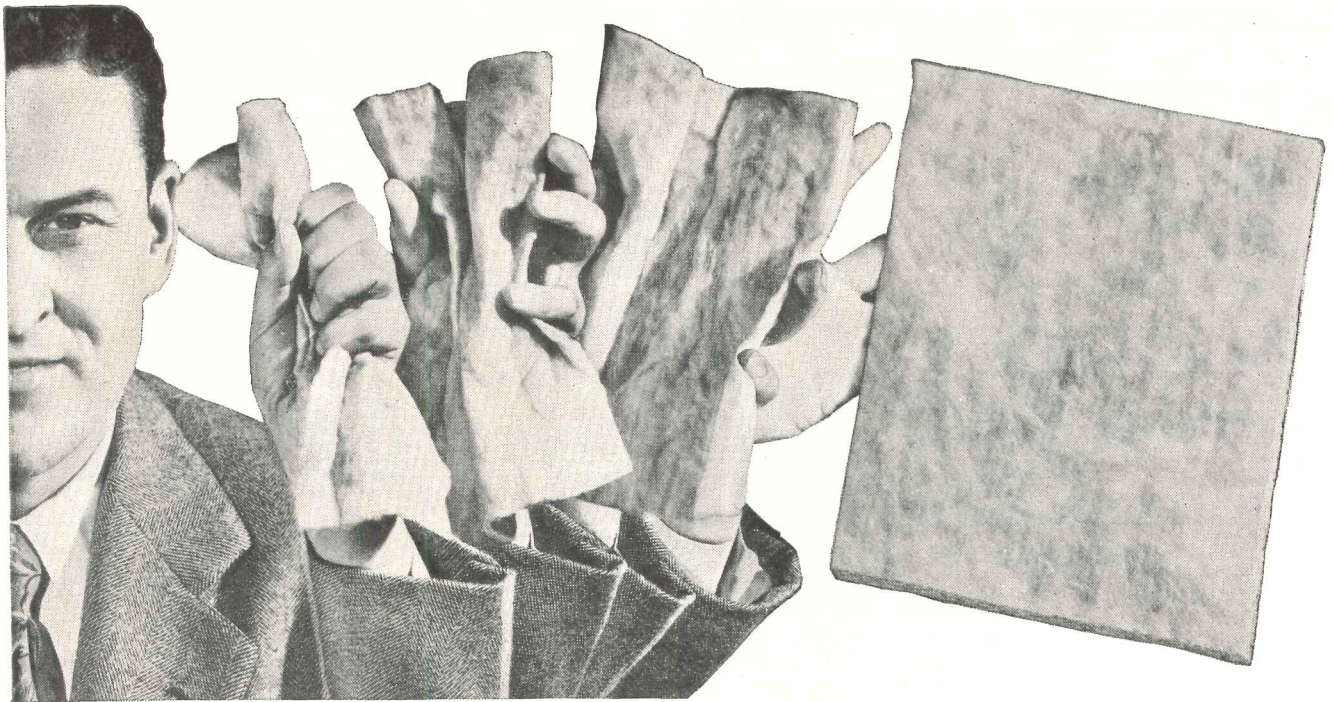

*Low Cost*  
**THIS NEW INSULATION**  
**WILL FIRE YOUR IMAGINATION**

You'll be able to do things with this new Fiberglas\* "Aerocor" that you've not been able to do before except by using a combination of insulation and sound-deadening materials. It's the first real all-purpose insulation . . . and it's low in cost . . . material cost, labor and maintenance.

New Fiberglas "Aerocor" is the greatest thing yet, because it's formed from millions of *super-fine* glass fibers . . . the myriad dead-air spaces they form serve to trap noise and hold back heat or cold, efficiently. "Aerocor" has a "k"-factor as low as 0.23 @ 75° F. mean. Product densities range from 0.3 to 1.0 pound per cubic foot and sound absorption coefficient up to 0.90.

And you can apply it just about any way

. . . cut it with a knife or scissors; fit and wrap it around irregular shapes and surfaces; tack it up, cement it, sew or tape it.

You can use it safely where ordinary insulation would rot or mildew, where vermin and rodents would attack, and where there's a fire-hazard . . . "Aerocor" glass fibers will not support combustion or rodents, cannot rot, won't settle under vibration.

By now you probably have ideas where to use Fiberglas "Aerocor" on your projects. Send for the free sample and booklet. Get the facts and data you need to specify Fiberglas "Aerocor" Insulation.

Owens-Corning Fiberglas Corporation, Dept. 831, Toledo 1, Ohio. Sales offices in 27 leading cities.

\*FIBERGLAS IS THE TRADEMARK (REG. U.S. PAT. OFF.) OF OWENS-CORNING FIBERGLAS CORPORATION FOR A VARIETY OF PRODUCTS MADE OF OR WITH GLASS FIBERS

OWENS-CORNING  
**FIBERGLAS**  
TRA. REG. U.S. PAT. OFF.

*A NAME THAT MEANS  
 EXTRA VALUE  
 IN INSULATION*

Owens-Corning Fiberglas Corp.,  
 Dept. 831, Toledo 1, Ohio.

I am interested in using Fiberglas "Aerocor" for \_\_\_\_\_

Please send me a sample of Fiberglas "Aerocor" and complete information.

Name \_\_\_\_\_

Firm \_\_\_\_\_

Address \_\_\_\_\_

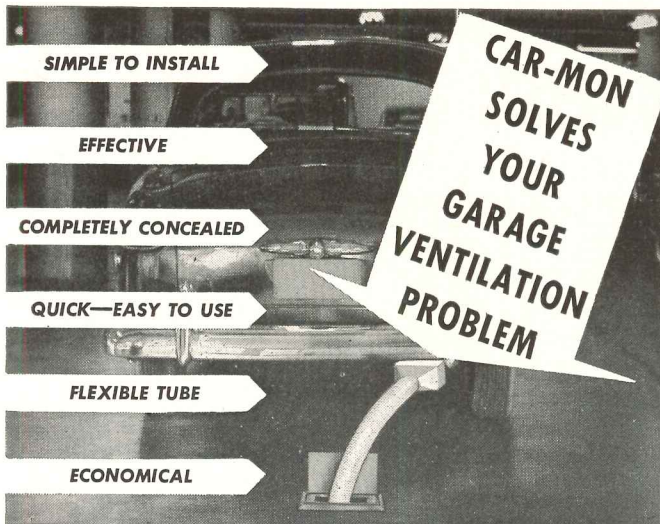

SIMPLE TO INSTALL

EFFECTIVE

COMPLETELY CONCEALED

QUICK—EASY TO USE

FLEXIBLE TUBE

ECONOMICAL

**CAR-MON  
SOLVES  
YOUR  
GARAGE  
VENTILATION  
PROBLEM**

## CAR-MON EXHAUST SYSTEMS

FOR CAR DEALERS, GARAGES AND REPAIR SHOPS

The newest and most effective way to remove dangerous carbon monoxide gas fumes from your garage or repair shop, for any number of cars. System completely concealed, easily and economically installed in present building or new constructions. Permits exhaust testing while in operation. Improves working conditions, safeguards employee's health. Widely used by Cadillac, Buick, Oldsmobile, Ford, Chevrolet and Chrysler dealers. Investigate Car-Mon today—write for details.

**CAR-MON PRODUCTS CO.**

4552 N. BROADWAY

CHICAGO 40, ILL.

## FOR DEAD-END SERVICE

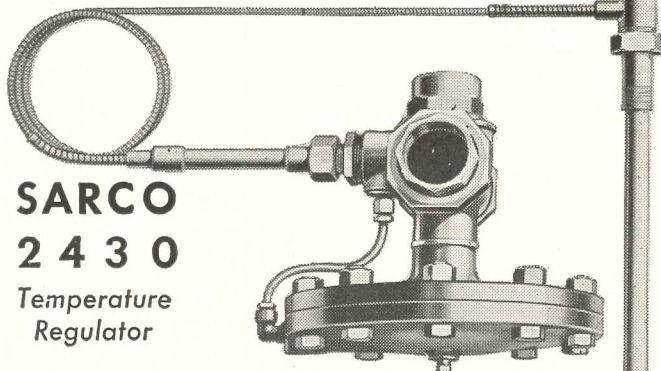

**SARCO  
2430**

Temperature  
Regulator

This simple pilot operated regulator assures trouble-free temperature control of instantaneous water or oil heaters where positive shut-off is required on no load.

The valve is single seated, stainless steel trimmed, and closes with the pressure. No creeping up of temperature after the valve closes.

Available calibrated for any temperature between 0 and 300°F.; adjustable in use plus-minus 25°F.; sizes ½" to 3", pressures to 175 p.s.i. Catalog 600.

215

**SARCO** SARCO COMPANY, INC.  
Empire State Bldg., New York 1, N.Y.  
**SAVES STEAM** SARCO CANADA, LTD., TORONTO 5, ONTARIO

*Hollow*

*Metal*

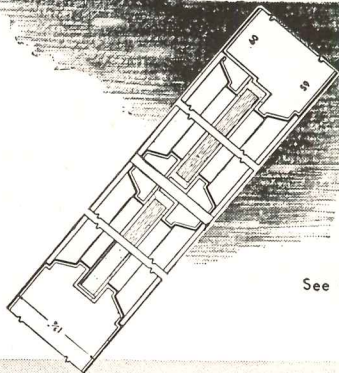

See Our Catalog in Sweet's

**JAMESTOWN METAL  
CORPORATION**

104 BLACKSTONE AVENUE

JAMESTOWN, N. Y.

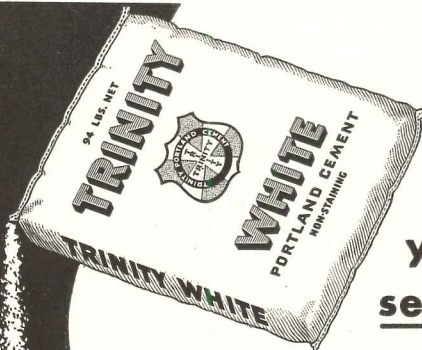

**you can  
see that**

*Trinity White*

**is the whitest  
white cement!**

You'll get fine results with this extra white cement. It's true Portland Cement made to ASTM and Federal Specifications. If your dealer does not have it, write the office nearest you: Trinity Portland Cement Division, General Portland Cement Co., 111 West Monroe St., Chicago; Republic Bank Bldg., Dallas; 816 W. 5th St., Los Angeles.

as white



as snow

# Announcing... A New Store Book

Ben Schnall Photo

## "Planning Stores That Pay"

by Dr. Louis Parnes, A.I.A.

for

Architects and Store Designers,  
Department and Chain Store  
Administrators

**"The great majority of department stores today are not making the most efficient use of their space,"**

says Dr. Louis Parnes, international authority on store planning.

**"This is due to haphazard growth and bad planning . . . The tremendous occupancy costs, which absorb 6% or more of gross sales, can be cut down in relation to sales by good design."**

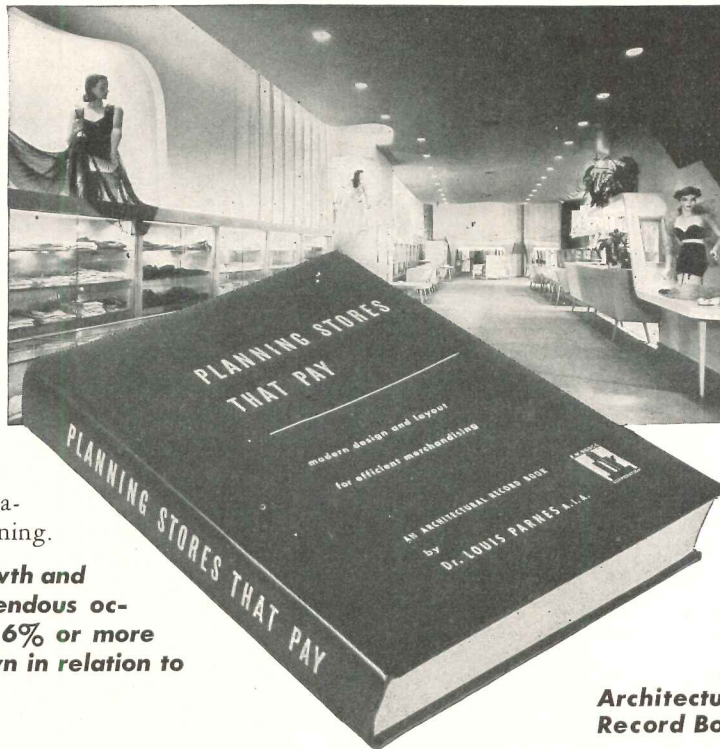

An  
Architectural  
Record Book

In his new comprehensive study "Planning Stores that Pay," Dr. Parnes demonstrates the amazing degree to which architecture — as expressed in counter lengths, traffic flow, etc. — speeds and increases retail sales, not only for department stores but for specialty and chain stores. Point by point he conducts a tour of the store to illustrate the right and wrong aspects of profit-making design. He shows how to compute such diverse factors as, say, the ideal width of show windows and the optimum number of chairs in a shoe department.

With more than 500 illustrations, he explores every detail of the store and its arrangements — entrances, arcades, show windows, transportation systems, furniture and fixtures, receiving and shipping facilities, floor and department layouts, display arrangement and lighting, and all the hundreds of items that go to make up a modern merchandising machine. Everything is calculated from the viewpoint of efficiency, and the contribution of each part of the store to the process of selling goods profitably is the criterion of its recommended design. Diagrams, charts and scale drawings, from hundreds of leading stores and from the works of America's greatest store architects, prove each point graphically.

### Why Every Department Store — Old or New — Now Needs an Architect's Service

Composite statistics of department store income and expense have long been put to invaluable use in stepping up store efficiency. Dr. Parnes shows how they also can be used as a precise basis for designs that automatically enhance sales . . . and reveals the enormous potential profits thus available. The first store to be thus fully engineered will have extraordinary advantages! *But meanwhile every department store in the country can begin at once to plan its architectural transformation.*

### A Basic Textbook on Store Architecture

"Planning Stores That Pay" is a book of basic principles, but specific ideas flow from its pages in rapid succession. A single chapter has enough suggestions to launch a number of long-term projects in store layout, equipment,

etc. Any department store administrator can see that it will pay him to call in private architects for immediate replanning, and that such replanning may well pay for itself a hundred times over.

Department stores have exhausted great resources of effort and ingenuity to maintain their life-line margin of profit. The fact that "Planning Stores That Pay" suddenly injects into this situation sensational new weapons for combatting competition makes this an extremely valuable, if not indispensable, book for architects and store administrators. With it they can speak each other's language, work together, and make the most of today's great opportunities.

### Order Your Copy Now

"Planning Stores That Pay" is now available to you at the price of \$15 per copy. But because the demand for this book is exceeding even the most sanguine expectations, the initial printing may soon be exhausted. Therefore, to make sure of your copy of this new, basic text on advanced store design and planning, order your copy now.

Use the convenient coupon at the right. The book will be sent promptly on receipt of your order . . . postpaid.

**Over 500 photographs and diagrams of floor plans, store fronts and interiors.**

Features 112 stores and shops . . . the work of more than 60 architects and designers.

300 pages; 8 3/4 x 11 1/4; heavy, durable, cloth binding; 80 lb. coated stock; Detailed Table of Contents; Comprehensive Index.

#### TABLE OF CONTENTS

1. Introductory Survey
2. City Planning Considerations
3. The Selling Zone
4. The Customers' Zone
5. The Merchandise Zone
6. The Show Window
7. The Personnel Zone
8. Interior Lighting
9. Circulation and Transportation
10. Scientific Surveys and Data

#### CONTENTS OF A TYPICAL CHAPTER

To indicate how logically and thoroughly this book deals with its subject, here are the section headings of a single chapter (Chapter 3, entitled "The Selling Zone"):

Space Organization. Coordination and Arrangement of Central Sales Areas. Relative Size of Departments. Circulation on Selling Floors: Aisle Layout; Aisle Densities; Equipment Layout. Fixture Specifications. Self-Service Equipment. Flexible and Standardized Equipment. Service Stations. Interior Display. Interior Column Spacing. Productivity, Efficiency, and Equipment Layout. Special Sales Rooms. New Trends in Basements. Main Floor Layout.

**A few of the architects and firms whose works are discussed are:**

Carson & Lundin  
Morris Lapidus  
Shreve, Lamb & Harmon  
Kenneth Franzheim  
Fred N. Severud  
Harry Devine  
William Lescaze  
H. Roy Kelley  
John S. Redden  
Albert C. Martin  
John M. Hutton  
Morris Ketchum, Jr.  
Ernest J. Kump  
Stiles O. Clemens

BOOK DEPARTMENT, ARCHITECTURAL RECORD  
119 West 40th Street, New York 18, N. Y.

Enclosed is \$..... for..... copy(s) of "Planning Stores That Pay," by Dr. Louis Parnes, A.I.A., at the price of \$15 per copy. For N. Y. C. add 2% sales tax.

Name.....

Address.....

City..... Zone..... State.....

# INDEX TO ADVERTISEMENTS

MANUFACTURERS' PRE-FILED CATALOGS  
 Symbols "a", "b", and "e" indicate that catalogs  
 of firms so marked are available in Sweet's Files  
 as follows:

a—Sweet's File, Architectural, 1949  
 b—Sweet's File for Builders, 1949  
 e—Sweet's File, Engineering, 1949

abe Adam, Frank Electric Co.....	51	Guth, Edwin F. Co.....	12	ae Otis Elevator Company.....	79
ae Aerofin Corporation.....	242	Haws Drinking Faucet Co.....	240	ae Owens-Corning Fiberglas Corp.....	56-245
Affiliated Gas Equipment, Inc.....	215	ae Haynes Products Co.....	228	Ozalid Division.....	230
Air Devices, Inc.....	218	a Herring-Hall-Marvin Safe Co.....	228	a Parker, Charles Company.....	178
Alan Wood Steel Co.....	30	Holophane Company, Inc.....	231	ab Permanente Products Co.....	149
a Alberene Stone Corp. of Virginia.....	160	ab Homasote Company.....	195	a Pittsburgh Paint Division.....	67
a Aluminum Company of America.....	39	a Hood Rubber Co.....	22	abe Pittsburgh Plate Glass Company.....	60-61-67-203
a Aluminum Window Manufacturers Assn.....	238	a Hope's Windows, Inc.....	42	Ponderosa Pine Woodwork.....	156
ae American Abrasive Metals Co.....	184	a Horn, A. C. Company, Inc.....	29	a Powers Regulator Company.....	78
a American Air Filter Company, Inc.....	166	a Horn Brothers Co.....	192	ae Pumice Producers Association.....	83
a American Brass Company.....	82	House & Garden.....	216	a Republic Steel Corporation.....	62-69-177-213
a American Hardware Corp.....	17	Hubbell, Harvey, Inc.....	208	abe Revere Copper & Brass, Inc.....	241
ae American Lumber & Treating Co.....	20	abe Hunter Fan & Ventilating Co., Inc.....	80	a Reynolds Metals Company.....	23-49-171
American Radiator & Standard Sanitary Corp.....	193	a Imperial Brass Mfg. Co.....	6	a Reynolds Metals Co.—Aluminum Division.....	23
ab American Telephone & Telegraph Co.....	58	Infra Insulation, Inc.....	182	ae Richards-Wilcox Mfg. Co.....	200
a Anaconda Copper Mining Co.....	82	International Nickel Company, Inc.....	239	ab Richmond Radiator Company.....	49
a Anchor Post Products, Inc.....	206	a Jackson & Church Co.....	3rd Cover	Rixson, Oscar C. Company.....	196
ae Anemostat Corp. of America.....	73	a Jamestown Metal Corp.....	246	ae Robertson, H. H. Company.....	64-65
Anthracite Institute.....	235	a Jenkins Bros.....	71	a Rotary Lift Co.....	44
ae Armstrong Cork Company.....	41	ae Johns-Manville.....	18	Royal Heaters, Inc.....	228
Asphalt Roofing Industry Bureau.....	27	ae Josam Mfg. Co.....	167	Russell & Erwin Division.....	17
ae Barber-Colman Company.....	188	a Kawneer Company.....	152	ab Russell, F. C. Company.....	240
ab Bell Telephone System.....	58	a Kennedy, David E., Inc.....	165	Samson Cordage Works.....	224
Benjamin Electric Mfg. Co.....	21	Kewaunee Mfg. Co.....	186	a Sanymetal Products Co., Inc.....	244
a Berger Manufacturing Division.....	69	Keystone Steel & Wire Co.....	74	Sarco Company, Inc.....	246
a Bethlehem Steel Company.....	34-197	ab Kimberly-Clark Corp.....	214	b Schundler, F. E. & Co., Inc.....	242
Bigelow Rugs & Carpets.....	189	Kinetic Chemicals, Inc.....	76-77	ae Scott Washroom Advisory Service.....	66
ab Bird & Son, Inc.....	190	Kohler Co.....	217	a Seaportel Metals, Inc.....	164
a Blank, Frederic & Co., Inc.....	169	a L.C.N. Closers, Inc.....	183	ab Serval, Inc.....	205
Books.....	212-220-234-247	ab Laclede Steel Company.....	222	ae Sloan Valve Company.....	4th Cover
e Bradley Washfountain Co.....	202	a Lawson, F. H. Co.....	236	Sloane-Blabon Corporation.....	35
a Brasco Mfg. Co.....	155	abe Libbey-Owens-Ford Glass Company.....	50	ab Smith, A. O. Corporation.....	19
Briggs Manufacturing Co.....	54-55	Lincoln Electric Company.....	159	a Smith, H. B. Co., Inc.....	210
ab Bruce, E. L. Co.....	163	Litecontrol Corporation.....	70	a Speakman Company.....	237
ab Bryant Heater Division.....	215	Lone Star Cement Corporation.....	1	a Stained Shingle & Shake Association.....	157
Byers, A. M. Co.....	4	ab Louisville Cement Company.....	63	a Steel & Tubes Division.....	62
ab Cabot, Samuel, Inc.....	204	Luria Engineering Corporation.....	243	ea Stewart Iron Works Co., Inc.....	226
Car-Mon Products Co.....	246	a Macomber, Incorporated.....	16	ae Swartwout Company.....	238
ae Carrier Corporation.....	249	ae Mahon, R. C. Company.....	45	Swedish Crucible Steel Co.....	11
a Casement Hardware Co.....	194	ae Maple Flooring Manufacturers Assoc.....	38	a Symmons Engineering Co.....	234
ab Ceco Steel Products Corp.....	2-3	a Marble Institute of America, Inc.....	72	a Tile Council of America.....	33
abe Celotex Corporation.....	48	Marlou Lights.....	173	ae Timber Structures, Inc.....	226
Certified Fleur-O-Lier Manufacturers.....	43	ab Marsh Wall Products, Inc.....	180	Todd Shipyards Corp.....	206
a Cheney Flashing Co.....	240	a Martin-Parry Corporation.....	25	abe Trane Company.....	187
Chicago Hardware Co.....	204	Masland Duralather Co.....	179	a Trinity Portland Cement Division.....	246
ab Cincinnati Fly Screen Division.....	240	a Master Metal Strip, Inc.....	14	abe Truscon Steel Company.....	213
Combustion Equipment Division.....	206	a Medart, Fred Products, Inc.....	53	Tyler, Arthur F. Co.....	244
Committee on Steel Pipe Research.....	201	a Medusa Portland Cement Co.....	236	a United States Gypsum.....	233
Connor, W. B. Engineering Corp.....	227	ab Mengel Company.....	185	ae United States Steel Corporation Subsidiaries.....	168
ab Connor Lumber & Land Co.....	179	abe Mesker Brothers.....	229	a Universal Atlas Cement Company.....	168
Corning Glass Works.....	199	Michaels Art Bronze Co.....	162	a Universal Corporation.....	75
b Crane Co.....	40	ea Mills Company.....	161	a Uvalde Rock Asphalt Co.....	174
Crucible Steel Company of America.....	36-37	Minneapolis-Honeywell Regulator Co.....	84	a Vonnegut Hardware Co.....	68
a Cutler Mail Chute Co.....	244	a Minwax Company, Inc.....	210	ae Wakefield, F. W. Brass Company.....	211
a Day-Brite Lighting, Inc.....	221	ae Modine Manufacturing Co.....	181	ae Webster, Warren & Co.....	212
Detroit Lubricator Company.....	13	a Nailock Steel Division.....	244	a Weis, Henry Mfg. Co.....	158
abe Detroit Steel Products Company.....	207	ab Nator Store Fronts.....	230	a Werner, R. D. Co., Inc.....	226
ae Dravo Corporation.....	191	ae National Electric Products Corp.....	81	West Dodd Lighting Conductor Corp.....	236
ae Du Pont, E. I. de Nemours & Co.....	225	a National Gypsum Company.....	46	abe Westinghouse Electric Corporation.....	15
a Duriron Co., Inc.....	222	a National Terrazzo & Mosaic Assoc.....	224	Weyerhaeuser End Matched Lumber.....	8-9
a Dwyer Products Corporation.....	173	e Nelson Herman Corporation.....	224	ae Wheeling Corrugating Company.....	59
Edwards Co., Inc.....	223	a New Castle Products.....	238	a Worthington Pump & Machinery Corp.....	209
Ellison Bronze Co.....	176	ae Okonite Company.....	222	Wurlitzer, Rudolph Company.....	31
Employment Opportunities.....	234-236	Olsonite Plastics Division.....	11	abe Zonolite Company.....	219
Enterprise Engine & Foundry Co.....	32	Onan, D. W. & Sons, Inc.....	208		
Faber, A. W. Castell Pencil Co., Inc.....	230				
e Fedders-Quigan Corporation.....	232				
abe Fiat Metal Mfg. Co.....	170				
a Fiske, J. W. Iron Works.....	242				
a Fitzgibbons Boiler Company.....	150				
Fleur-O-Lier Manufacturers.....	43				
abe Flintkote Company.....	2nd Cover				
ab Frigidaire Division.....	52				
ab Gate City Sash & Door Co.....	198				
General Aniline & Film Corp.....	230				
General Controls.....	244				
a General Electric—Wiring.....	57-175				
ab General Motors Co.....	52				
a General Portland Cement Co.....	246				
a Goodrich, B. F.....	22				
Grasselli Chemicals Dept.....	225				
ae Grinnell Company, Inc.....	47				

NEW YORK—H. Judd Payne, Publishing Director; Robert F. Marshall, Business Manager; Tom Tredwell, Advertising Mgr.; Benton B. Orwig, Creative Service Manager; M. A. Murphy, Advertising Production Manager, 119 West 40th Street; BOSTON—Harry M. Horn, Jr., 855 Park Square Bldg.; CHICAGO—C. B. Riemersma, Robert T. Franden, John M. Cogan, 700 Merchandise Mart; CLEVELAND—John C. Jackson, 321 Hanna Bldg.; DALLAS—O. O. Paulsell, 412 Construction Bldg.; LOS ANGELES—Bob Weiststein, 672 South Lafayette Park Place; PHILADELPHIA—Tom Tredwell, 1321 Arch St.; PORTLAND—Bob Weiststein, 907 Terminal Sales Bldg.; SAN FRANCISCO—Bob Weiststein, 1003 TWA Bldg., 240 Stockton St.



# A new lease on life for aging buildings

**A** BUILDING is only as old as its tenants feel it is, so no modernization program can afford to overlook air conditioning.

It increases the profitable span of a building's life by keeping old tenants from moving and by attracting new ones. Time and again it has proved a sound investment in all types of buildings — commercial structures, office and loft buildings, hotels, department and retail stores, hospitals and others.

The best investment, of course, is an installation that can be adapted to a building at the lowest cost consistent with efficient operation. For this purpose, you can depend on a Carrier system as being one engineered for the most effective, most economical answer. Pioneer and leader in the field, Carrier provides the right choice of several systems developed through practical experience that deliver year-round air conditioning at its best — proper temperature, humidity, circulation, ventilation and freedom from traffic dust, smoke and street noises.

For years Carrier engineers have teamed up with architects and consulting engineers to bring modern, efficient air conditioning to all types of buildings. Their know-how is invaluable, and they are glad to place it at your service, whether your problem involves air conditioning a few floors or all floors of an aging or new building. For an illustrated booklet describing Carrier's five different systems, write for Catalog AC173. Carrier Corporation, Syracuse, New York.



**Carrier**

AIR CONDITIONING • REFRIGERATION • INDUSTRIAL HEATING

# ARCHITECTURAL RECORD

Published by F. W. Dodge Corporation, 119 West 40th Street, New York 18

Copyright 1949. All rights reserved

SEMI-ANNUAL INDEX • VOLUME 105 • JANUARY-JUNE 1949

BTS—Building Types Study • TSS—Time-Saver Standards • AE—Architectural Engineering section

## A

Alaska, University of, Fairbanks, Alaska. Geophysical Institute. Federal Works Agency, archts.—April, p. 10.

Allinson, J. P. Article, "Design of Television Stations"—BTS—June, pp. 123-132; article, "Sky-hooks Raise Roof, Cut Costs"—AE—Jan., pp. 121-123.

Allison and Rible, Archts. House, Beverly Hills, Calif.—BTS—April, pp. 108-113.

Altenhof & Brown. See Harrison & Abramovitz.

Aluminum Company of America. New building planned in Pittsburgh, Pa. Harrison & Abramovitz, archts. Altenhof & Brown and Mitchell & Ritchey, assocs.—April, p. 168.

American Institute of Architects. Eighty-first national convention, Houston, Tex.; presentation of Gold Medal to Frank Lloyd Wright—May, pp. 86-91; report on annual meeting and election of officers—April, p. 10.

American Institute of Architects, New York Chapter. Announcement of annual LeBrun Traveling Scholarship competition—Jan., p. 10.

American Osteopathic Association. Office building, Chicago, Ill. Perkins & Will, archts. and engrs.—BTS—Jan., pp. 112-116.

Anicka, Walter T., Archt. Milan School (rural), Milan, Mich.—BTS—Mar., p. 119.

Apartment buildings. Eastgate Apartments, Cambridge, Mass., for Massachusetts Institute of Technology and New England Mutual Life Insurance Co., by Architects and Engineers for Eastgate Apartments (See Eastgate Apartments for complete listing)—Jan., pp. 88-89; BTS—Feb., pp. 107-123; Manhattan House, New York, N. Y., for New York Life Insurance Co.—May, pp. 106-107; North Vancouver, B. C.—May, p. 172; Zlin, Czechoslovakia—Jan., p. 96.

APARTMENTS. BTS No. 146—Eastgate Apartments as a new plan type—Feb., pp. 107-128.

"Architects Design for Industry." Article—June, pp. 102-115.

"Architectural Design and Abstract Art." Article based on Henry-Russell Hitchcock's book "Painting Toward Architecture" and exhibition at the Institute of Contemporary Design, Boston, Mass.—Jan., pp. 90-94.

"Architecture Abroad and Here." Review of periodicals—Jan., pp. 95-96.

Arhus University, Denmark. Assembly hall (one photo) shown in article, "Architecture Abroad and Here." C. F. Moller, Kay Fisker, Paul Stegman, archts.—Jan., p. 95.

"Art in Our Time." Editorial by Kenneth K. Stowell—Jan., p. 67.

Asensio W., Carlos. See Roosevelt Medical Center.

"Attic Condensation—Causes and Preventives." Article summarizing results of field and laboratory investigations by Forest Products Laboratory—AE—Feb., pp. 135-136.

## B

Bamberger and Reid, Archts. and Engrs. Fairfax Elementary School addition, Fairfax, Calif.—Jan., pp. 67-75.

Bank buildings. Bank of Montreal, Toronto, Ont.

—April, p. 156; Bank of Nova Scotia, Toronto, Ont.—May, p. 178.

Bank of Montreal. New building at Toronto, Ont. Chapman, Oxley & Facey, Marani & Morris, archts.; K. R. Blatherwick, assoc.—April, p. 156.

Bank of Nova Scotia. Head office building at Toronto, Ont. Mathers and Haldenby, Beck and Eadie, archts.—May, p. 178.

Bay Area Style. Article, "Is There a Bay Area Style?"—symposium of answers by "Bay Area" architects: William Wilson Wurster, Albert Henry Hill, John Ekin Dinwiddie, Gardner A. Dailey, Frederick L. Langhorst, Francis Joseph McCarthy, Robert Royston, Francis Violich, Edward Williams—May, pp. 92-97.

Beckwith, H. L. See "Glarefree Lighting Methods Studied by M.I.T."

Beelman, Claude, Archt. Radio and Television Station KHJ, Hollywood, Calif. Herman Spackler, assoc. archt.—BTS—June, p. 139.

Benson, A. B. See Roberts, Platt.

Bermuda. The Island Theater, Hamilton, Bermuda. Schlanger & Hoffberg, archts.; Reiser & Urbahn, archts.—April, pp. 86-91.

Birren, Faber. Article, "Functional Color in Hospitals"—AE—May, pp. 145-146.

Bitter, Mr. and Mrs. Francis. House near Cambridge, Mass. Carl Koch, archt.; Frederick L. Day, assoc.—Jan., pp. 76-83.

Black and West, Archts. Nowata Hospital, Nowata, Okla. Collins & Gould, mech. engrs.—BTS—May, pp. 120-121.

Blake, Peter, Dsnr. Projected house for Mr. and Mrs. Peter Blake, Locust Valley, N. Y.—BTS—April, pp. 130-131.

Block garden, Luzerne Street, Philadelphia, Pa. Oscar Stonorov, dsnr.—Feb., p. 24.

Boardman, Mrs. Ruth. "Cape Cod Cottage Styled for Summer," South Yarmouth, Mass. David Fried, archt.—Feb., pp. 104-106.

Breuer, Marcel, Archt. Expandable house for Museum of Modern Art (under construction)—Feb., p. 24; "House in the Museum Garden" opened to public—May, p. 10; house near Williamstown, Mass.—Feb., pp. 84-93, and April, p. 86.

Brewer School, Maine. Alonzo J. Harriman, archt.—BTS—Mar., p. 115.

Briardriff School, Seattle, Wash. George Wellington Stoddard and Assocs., archts. and engrs.—BTS—Mar., pp. 128-129.

Bristol Memorial Hospital, Bristol, Tenn.-Va. "100-Bed Hospital with Doctors' Office Building." Dent and Aydelott, archts.—May, pp. 124-127.

Brown, Harry E. See Roosevelt Medical Center.

Brown, William Hoskins. See Eastgate Apartments.

Browne, F. L. Article, "Water-Repellent Preservatives for Wood"—AE—Mar., pp. 131-132.

Brownyard, William H. See Roosevelt Medical Center.

Budget house for GI's. Model embodying modular planning, prefabrication and use of prefinished materials. Igor B. Polevitzky, archt.—BTS—April, p. 129.

Building Trades Employers' Association of New York City. See "Wage Stabilization Stimulates Building."

## C

Cabinetwork details. Based on information from Nuraco Woodwork, New Rochelle, N. Y.—TSS—AE—May, pp. 147, 153, 155; June, pp. 151, 153.

Caldwell Memorial Hospital, Caldwell, Idaho. Victor N. Jones & Assocs., archts. & engrs.—BTS—May, pp. 114-115.

Cannon, Will Alban, & Assocs., Archts.-Engrs. Placid Memorial Hospital, Lake Placid, N. Y. Basil C. MacLean, M.D., medical consultant—BTS—May, pp. 116-117.

Cape Cod houses. See "Confessions of a Cape Coddler."

Carson & Lundin, Archts. See Douglass, Lathrop.

Caudill, Rowlett, Scott, Archts. School, Blackwell, Okla.—BTS—Mar., p. 130.

Chapman, Oxley & Facey, Marani & Morris, Archts. K. R. Blatherwick, assoc. Bank of Montreal, Toronto, Ont.—April, p. 156.

Chapman, W. P., and Fischer, R. E. Article, "Second Thoughts on Radiant Heating"—AE—Mar., pp. 133-135.

City planning. See Block garden.

Civic centre, Toronto, Ont. John B. Parkin Assocs., archts.—Jan., p. 10.

Cocktail lounge. Embassy Lounge, Toronto, Ont. John B. Parkin Assocs., archts.; Robert Simpson Co., Ltd., interiors—Jan., p. 136.

"Codes, Costs and Standards." Editorial by Kenneth K. Stowell—Feb., p. 83.

Collins & Gould, Mech. Engrs. Nowata Hospital, Nowata, Okla. Black and West, archts.—May, pp. 120-121.

Color. See "Functional Color in Hospitals."

Community centers. See Hidden Talent Competition.

Community Memorial Hospital, Tracy, Calif. Fred L. Schwartz and William G. Hyberg, archts.—May, pp. 118-119.

Competitions. See Hidden Talent Competition; Le Brun Traveling Scholarship Competition; New York State Housing Competition.

Concrete construction. See "Precast System Developed for Low-Cost Dormitories."

Condensation. Article, "Attic Condensation—Causes and Preventives." Results of field and laboratory investigations by Forest Products Laboratory—AE—Feb., pp. 135-136.

"Confessions of a Cape Coddler." Article by Royal Barry Wills, archt.—BTS—April, pp. 132-134.

Conger, Harold G. See Roosevelt Medical Center.

Construction costs. See "Home Builders Debate Cost-Cutting Methods."

Construction Trades Council of Greater New York and Long Island. See "Wage Stabilization Stimulates Building."

Coolidge, Shepley, Bulfinch & Abbott, Archts. and Engrs. Lamont Library, Harvard University, Cambridge, Mass.—June, pp. 86-95.

"Cost Study of School Plan Types, A." Article by Alonzo J. Harriman—BTS—Mar., pp. 111-115.

Creole Petroleum Corp. Office building, Edificio Esso, Caracas, Venezuela. Lathrop Douglas, archt.; John W. Harris Assocs., construction management; Fred N. Severud, struct. engr.; Guy B. Panero, mech. engr.—BTS—Jan., pp. 96-103.

Cross, Eliot, Archt. Obituary—Mar., p. 18.  
 Crown Development Company. See "Heat Pump Undergoing Tests in Five Houses."  
 Czapek, Edmund L., Constr. & Research Dir. M.I.T. solar heated house, Cambridge, Mass. J. Frank Haws, dsnr.; M.I.T. Solar Energy Research Project, sponsor—AE—April, pp. 135-138.

## D

Dailey, Gardner A. See Bay Area Style.  
 Dale, George. See Roosevelt Medical Center.  
 Daltas, Spero Paul, Dsnr. Honorable Mention design of community center for Hidden Talent Competition; ARCHITECTURAL RECORD and Museum of Modern Art, co-sponsors—Mar., p. 94.  
 Davies, William. See Eastgate Apartments.  
 Day, Frederick L. See Koch, Carl.  
 DeMars, Vernon, Archt. See Eastgate Apartments.  
 Delman Theater, Dallas, Tex. Raymond F. Smith, archt.; A. E. Swank, Jr., assoc.—Jan., pp. 84-87.  
 Dent and Aydelott, Archts. Bristol Memorial Hospital, Bristol, Tenn.-Va. "100-Bed Hospital with Doctors' Office Building"—BTS—May, pp. 124-127.  
 "Design of Television Stations." Article by J. P. Allinson—BTS—June, pp. 123-132.  
 "Designers Extraordinary." Editorial by Kenneth K. Stowell—June, p. 85.  
 Dinwiddie, John Ekin. See Bay Area Style.  
 Doctors' office building. See Bristol Memorial Hospital.  
 Douglass, Lathrop, Archt. Office building, Edificio Esso, Caracas, Venezuela; John W. Harris Assocs., construction management; Fred N. Severud, struct. engr.; Guy B. Panero, mech. engr.—BTS—Jan., pp. 96-103. Office building, Esso Standard Oil Co., Baton Rouge, La. Carson & Lundin, assoc. archts.; John W. Harris, construction management; Guy B. Panero, mech. engr.; Strobel and Salzman, struct. engr.—BTS—Jan., pp. 104-107.  
 Dover School, Seattle, Wash. George Wellington Stoddard and Assocs., archts. and engr.—BTS—Mar., pp. 128-129.  
 Drew, Samuel T., Dir., Institute of Inter-American Affairs in Guatemala. Roosevelt Medical Center, Guatemala, Edmund J. Whiting, archt.-in-charge (for complete listing of archts., engr. and assocs., see Roosevelt Medical Center)—BTS—May, pp. 130-138.  
 Dryden, Allen N. See "Heat Pump Undergoing Tests in Five Houses."

## E

Eastgate Apartments, Cambridge, Mass. Apartment building for Massachusetts Institute of Technology and New England Mutual Life Insurance Co., by Archts. and Engrs. of Eastgate Apartments: M.I.T. staff members—William Hoskins Brown, archt. (liaison); Robert Woods Kennedy, archt.; Carl Koch, archt.; Vernon DeMars, consultant; Ralph Rapson, consultant, Dan Kiley (landscaping); Thomas Worcestor, Inc., organization—Thomas Worcestor, pres.; William Davies, archt.; G. Nelson Perry, struct. engr.; Charles A. Turner, mech. engr.; George I. Savage, elec. engr.; New England Mutual Housing Board—A. O. Willauer, arch. consultant; Hamilton Coolidge, asst. archt.—BTS—Feb., pp. 107-123; Jan., pp. 88-89.  
 Eckbo, Royston & Williams. See "Tamalpais House."  
 Edificio Esso, Caracas, Venezuela. Office building for Creole Petroleum Corp. Lathrop Douglass, archt.; John W. Harris Assocs., Inc., construction management; Fred N. Severud, struct. engr.; Guy B. Panero, mech. engr.—BTS—Jan., pp. 96-103.  
 Edmonds Grade School, Edmonds, Wash. William Arilda Johnson & Assocs., archts. "Transverse Framing Makes Top Daylight Economical"—BTS—Mar., pp. 126-127.  
 Edwards, Harlon H. Article, "Water-Repellent Preservatives Work on Wood"—AE—Feb., pp. 131-134.  
 Egan-Wyer, Terence. See Roosevelt Medical Center.  
 Electronics Park, Syracuse, N. Y. Research and manufacturing plant for General Electric Co. Giffels & Vallet, Inc., L. Rosetti, engr. and archts.—Feb., pp. 96-103.

Elkington, Robert, Archt. House, Ladue, Mo.—BTS—April, pp. 126-128.  
 Elwell. Article, "The Television Producing Plant"—BTS—June, p. 133.  
 Embassy Lounge, Toronto, Ont. John B. Parkin Assocs., archts.; Robert Simpson Co., Ltd., interiors—Jan., p. 136.  
 Entrance detail. Illinois Masonic Hospital, Chicago, Ill. Schmidt, Garden & Erikson, archts. Illustration for article, "Tomorrow's Hospitals," by Carl A. Erikson—BTS—May, p. 112.  
 Erikson, Carl A. Article, "Tomorrow's Hospitals"—BTS—May, pp. 109-112.  
 Esperance Grade School, Edmonds, Wash. William Arilda Johnson & Assocs., archts. "Transverse Framing Makes Top Daylight Economical"—BTS—Mar., p. 127.  
 Esso Building. Office building for Esso Standard Oil Co., Baton Rouge, La. Lathrop Douglass, archt.; John W. Harris Assocs., construction management; Carson & Lundin, assoc. archts.; Guy B. Panero, mech. engr.; Strobel and Salzman, engr.—Jan., pp. 104-107.  
 Esso Standard Oil Co. See Esso Building.  
 Everidge, G. J. Lee, Dsnr. Second Prize design of community center for Hidden Talent Competition; ARCHITECTURAL RECORD and Museum of Modern Art, co-sponsors—Mar., p. 90; winners of prizes announced—Feb., p. 10.  
 Expandable house. Model house under construction in garden of Museum of Modern Art. Marcel Breuer, archt.—Feb., p. 24.

## F

Facey, A. G., Archt. Industrial building for Visking Corp., Lindsay, Ont.—April, p. 10.  
 Fairfax Elementary School, Fairfax, Calif. Addition. Bamberger and Reid, archts. and engr.—Jan., pp. 67-75.  
 Falk, Mark. See Kump, Ernest J.  
 Fearney, Edward, A.I.A., Dsnr. Honorable Mention design of community center for Hidden Talent Competition; ARCHITECTURAL RECORD and Museum of Modern Art, co-sponsors—Mar., p. 94.  
 Federal Office Building and U. S. Court, Nashville, Tenn. Federal Works Agency project—May, p. 160.  
 Federal Works Agency, Archts. Federal Office Building and U. S. Court, Nashville, Tenn.—May, p. 160; Geophysical Institute, University of Alaska, Fairbanks, Alaska—April, p. 10.  
 "Fireproofing Structural Steel with Vermiculite Plaster"—TSS-AE—April, pp. 151, 153.  
 Fischer, R. E., and Chapman, W. P. Article, "Second Thoughts on Radiant Heating"—AE—Mar., pp. 133-135.  
 Fisker, Kay. See Arhus University.  
 Fitting room. Lord & Taylor store, Milburn, N. J.—April, p. 168.  
 Foreman, Clifford G., Dsnr. Honorable Mention design of community center for Hidden Talent competition; ARCHITECTURAL RECORD and Museum of Modern Art, co-sponsors—Mar., p. 93.  
 Forest Products Laboratory. See "Attic Condensation—Causes and Preventives."  
 France, Roy F., & Sons, Archts. Saxony Hotel, Miami Beach, Fla.—Mar., p. 172.  
 Fried, David, Archt. House for Mrs. Ruth Boardman, South Yarmouth, Mass.—Feb., pp. 104-106.  
 Fujikawa, Joseph Y., Dsnr. First Prize design of community center for Hidden Talent Competition; ARCHITECTURAL RECORD and Museum of Modern Art; co-sponsors—Mar., p. 89; winners of prizes announced—Feb., p. 10.  
 "Functional Color in Hospitals." Article by Faber Birren—AE—May, pp. 145-146.

## G

Galiad County Hospital, Galiad, Tex. J. G. Smyth Jr., archt.—BTS—May, p. 114.  
 Garnard, J. C. See "Heat Pump Undergoing Tests in Five Houses."  
 General Electric Co. Electronics Park, Syracuse, N. Y. Giffels & Vallet, Inc., L. Rosetti, engr. and archts.—Feb., pp. 96-103.  
 General Petroleum Corp. Office building, Los Angeles, Calif. Wurdeman and Becket, archts.—April, p. 170.  
 Geophysical Institute, University of Alaska, Fairbanks, Alaska. Federal Works Agency, archts.—April, p. 10.

Giffels & Vallet, Inc., L. Rosetti, Engrs. and Archts. Electronics Park, Syracuse, N. Y. Research and manufacturing center for General Electric Co.—Feb., pp. 96-103.  
 "Glarefree Lighting Methods Studied by M.I.T." Article by H. L. Beckwith, C. M. F. Peterson and Parry Moon—AE—June, pp. 145-147.  
 Goodwin, James F. See Roosevelt Medical Center.  
 Guatemala. See Roosevelt Medical Center.  
 Gutheim, Frederick. Article, "Rebuilding the White House"—June, pp. 116-120.  
 Gutterson, Alston G. See Roosevelt Medical Center.

## H

Hale, Mr. and Mrs. Marshall Jr. House, Burlingame, Calif. Clarence W. W. Mayhew, archt.—May, pp. 98-105.  
 Harriman, Alonzo J. Article, "A Cost Study of School Plan Types"—BTS—Mar., pp. 111-115; article, "School Planning and School Costs"—April, pp. 98-101.  
 Harriman, Alonzo J., Archt. Brewer School, Maine—BTS—Mar., p. 115.  
 Harriman, Alonzo J., Inc., Archts.-Engrs. Memorial High School and Gymnasium, Calais, Maine—BTS—Mar., pp. 116-118.  
 Harris, Harwell, Archt. House plan featuring kitchen as center of home. Illustration for article, "Home Life and House Architecture," by Arthur McK. Stires—BTS—April, p. 104.  
 Harris, John W., Assocs. See Edificio Esso and Esso Building.  
 Harrison & Abramovitz, Archts.; Altenhof & Brown and Mitchell & Ritchey, Assocs. Projected building for Aluminum Company of America, Pittsburgh, Pa.—April, p. 168.  
 Hartford, Conn. The New Theater, project for Paton Price and Assocs. Frank Lloyd Wright, archt. Model exhibited by Museum of Modern Art—May, p. 156.  
 Harvard University. See Lamont Library.  
 Haun, Paul, M.D., D.M.S. in Neurology. Article, "Psychiatric Facilities for the General Hospital"—BTS—May, pp. 128-129.  
 Haws, J. Frank, Dsnr. M.I.T. solar-heated house, Cambridge, Mass. Edmund L. Czapek, construction & research dir.; M.I.T. Solar Energy Research Project, sponsor—AE—April, pp. 135-138.  
 "Heat Pump Undergoing Tests in Five Houses." Article by Philip Sporn and E. R. Ambrose. Houses (one photo, one floor plan, one cross section of each): Kingsport, Tenn., Allen N. Dryden, archt.; Abington, Va., Virgil Odum, genl. contractor; Roanoke, Va., J. C. Garnard, genl. contractor; Coshocton, Ohio, Tibbals-Crumley, Musson, archts.; South Bend, Ind., Crown Development Co., contractor—AE—May, pp. 140-144, 182, 184.  
 Heating. See "Heat Pump Undergoing Tests in Five Houses"; "M.I.T. Builds Solar-Heated House"; "Prefabricated Floor Panels for Large Buildings"; "Progress in House Heating Equipment"; "Second Thoughts on Radiant Heating"; Solar Heating.  
 Hidden Talent Competition. ARCHITECTURAL RECORD and Museum of Modern Art, co-sponsors. Announcement of prizewinners—Feb., p. 10; report of the jury, Joseph Hudnut, chairman, and selected designs from entries: Spero Paul Daltas, dsnr. (p. 94; Honorable Mention); G. J. Lee Everidge, dsnr. (p. 90; Second Prize); Edward M. Fearney, A.I.A., dsnr. (p. 94, Honorable Mention); Clifford G. Foreman, dsnr. (p. 93, Honorable Mention); Joseph Y. Fujikawa, dsnr. (p. 89, First Prize); James V. Hirsch, dsnr. (p. 96, Honorable Mention); Elnor M. Hoops, dsnr. (p. 95, Honorable Mention); Herbert Johnson, dsnr. (p. 92, Honorable Mention); Mary Ellen Linberger, dsnr. (p. 96, Honorable Mention); Louis F. Mammier, dsnr. (p. 93, Honorable Mention); George E. Rafferty, dsnr. (p. 95, Honorable Mention); William R. Reed, dsnr. (p. 92, Honorable Mention); Edward Chase Weren, dsnr. (p. 91, Third Prize)—Mar., pp. 86-96.  
 Hill, Albert Henry. See Bay Area Style.  
 Hill, Henry, Dsnr. House plan illustrating indoor-outdoor relationships in planning. Illustration for article, "Home Life and House Architecture," by Arthur McK. Stires—BTS—April, p. 107; "Tamalpais House," near San Francisco, Calif.—June, pp. 96-101.

Hirsch, James V., Dsnr. Honorable Mention design of community center for Hidden Talent Competition; ARCHITECTURAL RECORD and Museum of Modern Art, co-sponsors—Mar., p. 96.

"Home Builders Debate Cost-Cutting Methods." Article reporting on cost-cutting clinics at Home Builders' Convention—AE—April, pp. 146, 190, 192, 194.

"Home Life and House Architecture." Article by Arthur McK. Stires—BTS—April, pp. 103-107.

Hoops, Elnor M., Dsnr. Honorable Mention design of community center for Hidden Talent Competition; ARCHITECTURAL RECORD and Museum of Modern Art, co-sponsors—Mar., p. 95.

Hospital Facilities, Division of. See Physical Therapy Suites.

Hospital for Washington Court House, Fayette County, Ohio. Insko, Brand and Insko, archts.—BTS—May, p. 117.

Hospital planning. See "Functional Color in Hospitals"; "Hospital Planning—Study in Ingenuity"; "Tomorrow's Hospitals."

"Hospital Planning—Study in Ingenuity." Article ("Early Hospitals in Federally Aided Program Show Wide Range of Ideas")—BTS—May, p. 113.

HOSPITALS. BTS No. 149—May, pp. 108-139.

Hospitals. Bristol Memorial Hospital, Bristol, Tenn.—Va.—May, pp. 124-127; Caldwell Memorial Hospital, Caldwell, Idaho—May, pp. 114-115; Community Memorial Hospital, Tracy, Calif.—May, pp. 118-119; Galiad County Hospital, Galiad, Tex.—May, p. 114; Great Lakes Naval Hospital, special accommodations for crutch and wheel chair patients in new theater—April, p. 166; Hospital for Washington Court House, Fayette County, Ohio—May, p. 117; Illinois Masonic Hospital (main entrance detail), Chicago, Ill.—May, p. 112; Lawrence County Memorial Hospital, Lawrence County, Ill.—May, p. 116; Mercy Hospital, Chicago, Ill.—May, p. 111; Nowata Hospital, Nowata, Okla.—May, pp. 120-121; Nurses' Home, Hospital of the University of Pennsylvania—May, p. 110; Placid Memorial Hospital, Lake Placid, N. Y.—May, pp. 116-117; proposed hospital at St. Lo, France—Jan., pp. 95-96; St. Elizabeth Hospital, Dayton, Ohio—May, p. 110; St. Joseph's Hospital, Lancaster, Pa.—May, p. 111.

Hotel. Saxony Hotel, Miami Beach, Fla. Roy F. France & Sons, archts.—Mar., p. 172.

House. See Expandable house.

"House in the Museum Garden." Museum of Modern Art, sponsor; Marcel Breuer, dsnr.—May, p. 10.

House plans. Illustrations for article, "Home Life and House Architecture," by Arthur McK. Stires: Marcel Breuer, archt. (evolution of master bedroom as private apartment); Harwell Harris, archt. (revival of kitchen as center of home); Henry Hill, dsnr. (indoor-outdoor relationships in planning); Howard Moise, archt. (segregation of children's quarters); Schweiker and Elting, archts. (revival of kitchen as center of home); Hugh Stubbins, archt. (segregation of children's quarters); Paul Thiry, archt. (segregation of children's quarters); Wurdeman & Becket, archts. (revival of kitchen as center of home); Wurster and Bernardi, archts. (evolution of master bedroom as private apartment)—BTS—April, pp. 103-107.

HOUSES. BTS No. 148—April, pp. 102-134.

Houses. Beverly Hills, Calif.—April, pp. 108-113; Mr. and Mrs. Marshall Hale Jr., Burlingame, Calif.—May, pp. 98-105; Mrs. Ruth Boardman, South Yarmouth, Mass.—Feb., pp. 104-106; Mr. and Mrs. Francis Bitter, Cambridge, Mass.—Jan. pp. 76-83; Concord, Mass.—April, pp. 114-117; Contra Costa County, Calif.—April, pp. 122-125; Ladue, Mo.—April, pp. 126-128; Malibu Beach, Calif.—April, pp. 118-121; model budget house for GI's—April, p. 129; projected house for Mr. and Mrs. Peter Blake, Locust Valley, N. Y.; "Tamalpais House," near San Francisco, Calif.—April, pp. 130-131. "Test House Heated Only by Solar Heat (AE), Dover, Mass.—Mar., pp. 136-137; Mr. and Mrs. George P. Turner, La Canada, Calif.; Williams-town, Mass.—Feb., pp. 84-93.

Houses. See "Home Life and House Architecture." Housing project. "Manhattan House" project of New York Life Insurance Co. Mayer & Whittle-

sey—Skidmore, Owings & Merrill, assoc. archts.—May, pp. 106-107.

Howell, John T. See Roosevelt Medical Center.

Hudnut, Joseph. See Hidden Talent Competition. Hughs & Olds, Archts. FM Radio Station KWKC, Abilene, Tex.—BTS—June, p. 141.

Hyberg, William G. See Schwartz, Fred L.

## I

Illinois Masonic Hospital, Chicago, Ill. Main entrance detail. Schmidt, Garden & Erickson, archts.—BTS—May, p. 112.

Industrial buildings. Electronics Park, Syracuse, N. Y.—Feb., pp. 96-103; Visking Corp. building, Lindsay, Ont.—April, p. 10.

Industrial design. See "Architects Design for Industry."

Insko, Brand and Insko, Archts. Hospital for Washington Court House, Fayette County, Ohio—BTS—May, p. 117.

Irigoyen, Roberto. See Roosevelt Medical Center. "Is There a Bay Area Style?" Article—symposium of answers by "Bay Area" archts.: William Wilson Wurster, Albert Henry Hill, John Ekin Dinwiddie, Gardner A. Dailey, Frederick L. Langhorst, Francis Joseph McCarthy, Robert Royston, Francis Violich, Edward Williams—May, pp. 92-97.

Island Theater, The, Hamilton, Bermuda. Schlanger & Hoffberg, archts.; Reisner & Urbahn, archts.—April, pp. 86-91.

## J

Johnson, Herbert, Dsnr. Honorable Mention design of community center for Hidden Talent Competition; ARCHITECTURAL RECORD and Museum of Modern Art, co-sponsors—Mar., p. 92.

Johnson, William Arilda, & Assocs., Archts. Edmonds Grade School, Edmonds, Wash. "Transverse Framing Makes Top Daylight Economical"—BTS—Mar., pp. 126-127; Esperance Grade School, Edmonds, Wash. (see above)—BTS—Mar., p. 127.

Jones, Victor N., & Assocs., Archts. & Engrs. Caldwell Memorial Hospital, Caldwell, Idaho—BTS—May, pp. 114-115.

## K

K-W System. See Wiggs, G. Lorne.

Kaelber & Waasdorp, Archts. Radio and Television Station WHAM, Rochester, N. Y.—BTS—June, p. 140.

Kaelber, William G., Archt. Obituary—Jan., p. 18. Kennedy, Robert Woods. See Eastgate Apartments.

Kiley, Dan. See Eastgate Apartments.

Kingsport, Tenn. See "Heat Pump Undergoing Tests in Five Houses."

Knopp, William K., Archt. Apartment building, cooperative, North Vancouver, B. C.—May, p. 172.

Koch, Carl. See Eastgate Apartments.

Koch, Carl, Archt., Frederick L. Day, Assoc. House for Mr. and Mrs. Francis Bitter, Cambridge, Mass.—Jan., pp. 76-83.

Kolbe, Henry W. See Roosevelt Medical Center.

Kump, Ernest J., and Mark Falk, Archts. Shoreview School, San Mateo, Calif.—BTS—Mar., pp. 120-125.

## L

Lamont Library, Harvard University, Cambridge, Mass. Coolidge, Shepley, Bulfinch & Abbott, archts. and engrs.—June, pp. 86-95.

Landscaping. See Block garden.

Langhorst, Frederick L. See Bay Area Style.

Lankton, J. Fletcher, John N. Ziegele and Assocs., Archts. and Engrs., Owners and Dsnrs. Office building, Peoria, Ill. Scruggs and Hammond, landscape archts.—Mar., pp. 97-99.

Lawrence County Memorial Hospital, Lawrence County, Ill. Lester W. Routt, archt. and engr.—BTS—May, p. 116.

LeBrun Traveling Scholarship Competition. Announcement of opening by New York Chapter, American Institute of Architects, sponsor—Jan., p. 18.

Library. Lamont Library, Harvard University, Cambridge, Mass.—June, pp. 86-95.

Linberger, Mary Ellen, Dsnr. Honorable Mention

design of community center for Hidden Talent Competition; ARCHITECTURAL RECORD and Museum of Modern Art, co-sponsors—Mar., p. 96.

Long, O. W. Jr. See Roberts, Platt.

Lumber Fabricators, Inc. Tri-Level Home Model; three-bedroom house for mass production—Mar., p. 166.

## M

McCarthy, Francis Joseph. See Bay Area Style.

MacLean, Basil C. See Cannon, Will Alban.

Mammier, Louis F., Dsnr. Honorable Mention design of community center for Hidden Talent Competition; ARCHITECTURAL RECORD and Museum of Modern Art, co-sponsors—Mar., p. 93.

"Manhattan House," New York, N. Y. Apartment project for New York Life Insurance Co. Mayer & Whittlesey—Skidmore, Owings & Merrill, Assoc. Archts.—May, pp. 106-107.

Massachusetts Institute of Technology. See Eastgate Apartments; "Glarefree Lighting Methods Studied by M.I.T.;" "M.I.T. Builds Solar-Heated House;" "Test House Heated Only by Solar Heat."

Mathers and Haldenby and Beck and Eadie, Archts. Head office for Bank of Nova Scotia, Toronto, Ont.—May, p. 178.

Mayer & Whittlesey—Skidmore, Owings & Merrill, Assoc. Archts. "Manhattan House," housing project—May, pp. 106-107.

Mayhew, Clarence W. W., Archt. House, Contra Costa County, Calif.—BTS—April, pp. 122-125; house for Mr. and Mrs. Marshall Hale Jr., Burlingame, Calif.—May, pp. 98-105.

Medical centers. New York University-Bellevue Medical Center, New York, N. Y.—Mar., p. 10; Northwestern University Medical Center, Chicago, Ill.—BTS—May, p. 112; Roosevelt Medical Center, Guatemala—BTS—May, pp. 130-138.

Mercy Hospital, Chicago, Ill. Schmidt, Garden & Erikson, archts.—BTS—May, p. 111.

Mexico. Article, "So You're Going to Mexico," by Susanne Wasson-Tucker—Mar., pp. 100-105.

Milan School, Milan, Mich. Walter T. Anicka, archt.—BTS—Mar., p. 119.

"Mind Reading?" Editorial by Kenneth K. Stowell—April, p. 85.

"M.I.T. Builds Solar-Heated House." Article on test house combining solar with electric auxiliary heat. J. Frank Haws, dsnr.; Edmund L. Czapek, constr. & research dir.—AE—April, pp. 135-138.

Mitchell & Ritchey. See Harrison & Abramovitz. Modular Design Data for Wood Windows—TSS—AE—Mar., pp. 138, 143, 145.

Moise, Howard, Dsnr. House plan featuring segregation of children's quarters. Illustration for article, "Home Life and House Architecture," by Arthur McK. Stires—BTS—April, p. 105.

Moller, C. F. See Arhus University.

Moon, Parry. See "Glarefree Lighting Methods Studied by M.I.T."

Museum of Modern Art. Expandable house under construction in Museum sculpture garden, Marcel Breuer, archt.—Feb., p. 24; Hidden Talent Competition, prizewinners announced, ARCHITECTURAL RECORD and Museum of Modern Art, co-sponsors—Feb., p. 10; Hidden Talent Competition, report of the jury, Joseph Hudnut, chairman, and selected designs from entries: Spero Paul Daltas, dsnr. (p. 94, Honorable Mention); G. J. Lee Everidge, dsnr. (p. 90, Second Prize); Edward M. Fearney, A.I.A., dsnr. (p. 94, Honorable Mention); Clifford G. Foreman, dsnr. (p. 93, Honorable Mention); Joseph Y. Fujikawa, dsnr. (p. 89, First Prize); James V. Hirsch, dsnr. (p. 96, Honorable Mention); Elnor M. Hoops, dsnr. (p. 95, Honorable Mention); Herbert Johnson, dsnr. (p. 92, Honorable Mention); Mary Ellen Linberger, dsnr. (p. 96, Honorable Mention); Louis F. Mammier, dsnr. (p. 93, Honorable Mention); George E. Rafferty, dsnr. (p. 95, Honorable Mention); William R. Reed, dsnr. (p. 92, Honorable Mention); Edward Chase Weren, dsnr. (p. 91), Third Prize—Mar., pp. 86-96; "House in the Museum Garden" opened to public—May, p. 10. See also New Theater, The.

## N

- Nelson, Gilbert, Mersier et Sebillotte, Archts. Proposed hospital, St. Lo, France. Illustration for article, "Architecture Abroad and Here"—Jan., pp. 95-96.
- Nelson & Goldberg, Archts. & Engrs. Radio and Television Station WICU, Erie, Pa.—BTS—June, p. 138.
- New England Mutual Life Insurance Co. Eastgate Apartments, apartment building for Massachusetts Institute of Technology, by Archts. and Engrs. of Eastgate Apartments: M.I.T. staff members: William Hoskins Brown, archt. (liaison); Robert Woods Kennedy, Carl Koch, archts.; Vernon DeMars, Ralph Rapson, consultants; Dan Kiley, landscaping; Thomas Worcester, Inc., Organization: Thomas Worcester, Pres.; William Davies, archt.; G. Melson Perry, struct. engr.; Charles A. Turner, mech. engr.; George I. Savage, elec. engr.; New England Mutual Housing Bd.: A. O. Willauer, arch. consultant; Hamilton Coolidge, asst. archt.—BTS—Feb. pp. 107-123.
- New York Chapter, American Institute of Architects. Announcement of annual competition for LeBrun Traveling Scholarship—Jan., p. 10.
- New York Life Insurance Company. "Manhattan House," New York, N. Y. Apartment building, housing project. Mayer & Whittlesey—Skidmore, Owings & Merrill, Assoc. Archts.—May, pp. 106-107.
- New York State Housing Competition. Winners announced—Jan., p. 12.
- New York University-Bellevue Medical Center, New York, N. Y. Architects' model. Skidmore, Owings & Merrill, archts.—Mar., p. 10.
- Northwestern University Medical Center, Chicago, Ill. Schmidt, Garden & Erikson, archts. Illustration for article, "Tomorrow's Hospitals," by Carl A. Erikson—BTS—May, p. 112.
- Nowata Hospital, Nowata, Okla. Black and West, archts.; Colins & Gould, mech. engr.—BTS—May, pp. 120-121.
- Nuroco Woodwork, New Rochelle, N. Y. Information for tables, Cabinetwork Details—TSS-AE—May, pp. 147, 153, 155.
- Nurses' Home, Hospital of the University of Pennsylvania. Schmidt, Garden & Erikson, archts. Illustration for article, "Tomorrow's Hospitals," by Carl A. Erikson—BTS—May, p. 110.

## O

- Odum, Virgil. See "Heat Pump Undergoing Tests in Five Houses."
- Office building, doctors'. See Bristol Memorial Hospital.
- Office building, small. See American Osteopathic Association.
- OFFICE BUILDINGS. BTS No. 145—Jan., pp. 97-116.
- Office buildings. Edificio Esso, Caracas, Venezuela—Jan., pp. 96-103; Esso Building, Baton Rouge, La.—Jan., pp. 104-107; Federal Office Building and U. S. Court, Nashville, Tenn.—May, p. 160; General Petroleum Corp. Building, Los Angeles, Calif.—April, p. 170; office of J. Fletcher Lankton, John N. Ziegele and Assocs., archts. and engrs., Peoria, Ill.—Mar., pp. 97-99; project for Tulsa, Okla.—Mar., p. 162; Waterman Steamship Corp. Building, Mobile, Ala.—Jan., pp. 108-111.
- Office of Naval Research, U. S. Navy, Archts. Experimental television station for teaching, Sands Point, L. I., N. Y.—BTS—June, pp. 136-137.
- Olivares, Jacquin. See Roosevelt Medical Center.

## P

- Panero, Guy B. See Douglass, Lathrop.
- Parkin, John B., Assocs., Archts. Civic Centre, Toronto, Ont.—Jan., p. 10; Embassy Lounge, Toronto, Ont. Robert Simpson Co., Ltd., interiors—Jan., p. 136.
- Parnes, Dr. Louis. Article, "Show Window Designs to Prevent Glare" (excerpts from *Planning Stores that Pay*)—TSS-AE—Feb., pp. 137, 141, 143.
- Peabody, Miss Amelia. See Solar heating.
- Pennsylvania, University of. Nurses' Home for hospital. Schmidt, Garden & Erikson, archts. Illustration for article, "Tomorrow's Hospitals," by Carl A. Erikson—BTS—May, p. 110.
- Perkins & Will, Archts. and Engrs. Small office building for American Osteopathic Association, Chicago, Ill.—BTS—Jan., pp. 112-116.
- Peru. Tacna Theater, Lima. Schlanger & Hoffberg, archts.; Reiser & Urbahn, archts.—April, pp. 92-97.
- Peterson, C. M. F. See "Glarefree Lighting Studied by M.I.T."
- Physical Therapy Suites. Plans developed in cooperation with American Physical Therapy Association by Division of Hospital Facilities, U. S. Public Health Service—BTS—May, pp. 122-123.
- Placid Memorial Hospital, Lake Placid, N. Y. Will Alban Cannon & Assocs., archt.-engrs. Basil C. MacLean, M.D., medical consultant—BTS—May, pp. 116-117.
- Planning Stores that Pay. See "Show Window Designs to Prevent Glare."
- Polevitzky, Igor B., Archt. Budget house for GI's. Model embodying modular planning, prefabrication, and use of prefinished materials—BTS—April, p. 129.
- "Precast System Developed for Low-Cost Dormitories." Article—AE—June, pp. 145-147.
- "Prefabricated Floor Panels for Large Buildings." Article by G. Lorne Wiggs—AE—Jan., pp. 117-120.
- Price, Paton, and Assocs. The New Theatre project, Hartford, Conn. Frank Lloyd Wright, archt. Model exhibited by Museum of Modern Art—May, p. 156.
- "Progress in House Heating Equipment." Article by Clifford Strock—AE—April, pp. 139-145.
- "Psychiatric Facilities for the General Hospital." Article by Paul Haun, M.D., D.M.S. in Neurology—BTS—May, pp. 128-129.

## R

- Radiant Heating. See "Second Thoughts on Radiant Heating."
- RADIO AND TELEVISION BUILDINGS. BTS No. 150—June, pp. 120-141.
- Radio and television stations. Experimental television station for teaching, Sands Point, L. I., N. Y.—June, pp. 136-137; Station KHJ, Hollywood, Calif.—June, p. 139; Station WBZ, Boston, Mass.—June, pp. 134-135; Station WHAM, Rochester, N. Y.—June, p. 140; Station WICU, Erie, Pa.—June, p. 138.
- Radio stations. Station KWKC, Abilene, Tex.—June, p. 141. See also Radio and television stations.
- Raetze, Griswold, Archt. House, Malibu Beach, Calif.—BTS—April, pp. 118-121.
- Rafferty, George E., Dsnr. Honorable Mention design of community center for Hidden Talent Competition; ARCHITECTURAL RECORD and Museum of Modern Art, co-sponsors—Mar., p. 95.
- Rapson, Ralph. See Eastgate Apartments.
- Rassweiler, C. F. Article, "Research in the Construction Industry"—AE—Feb., pp. 129-130.
- Raymond, Eleanor, Archt. "Test House Heated Only by Solar Heat," residence of Dr. Maria Telkes, Dover, Mass. Miss Amelia Peabody, sponsor—AE—Mar., pp. 136-137.
- "Rebuilding the White House." Article by Frederick Gutheim—June, pp. 116-120.
- Reed, William R., Dsnr. Honorable Mention design of community center for Hidden Talent Competition; ARCHITECTURAL RECORD and Museum of Modern Art; co-sponsors—Mar., pp. 92.
- Reiser & Urbahn. See Schlanger & Hoffberg.
- "Research in the Construction Industry." Article by C. F. Rassweiler—AE—Feb., pp. 129-130.
- "Revelation by Competition." Editorial by Kenneth K. Stowell—Mar., p. 85.
- Richards, Henry E., Archt. Obituary—Mar., p. 18.
- Roberts, Platt, Archt. Office building for Waterman Steamship Corp., Mobile, Ala. O. W. Long Jr. and A. B. Benson, assoc. archts.—BTS—Jan., pp. 108-111.
- Roof construction. See "Skyhooks Raise Roof, Cut Costs"; "Roof Trusses for Small Houses."
- "Roof Trusses for Small Houses"—TSS-AE—Jan., pp. 129, 131.
- Roosevelt Medical Center, Guatemala. Edmund J. Whiting, archt.-in-charge; Samuel T. Drew, dir. of Institute of Inter-American Affairs in Guatemala; assoc. archts.—Roberto Irigoyen, William H. Brownard, Carlos Asensio W., Hartwell M.

- Webb, Jacquin Olivares; mech.-elec. engr.—Warren Viessman, George Dale; assoc. mech.-elec. engr.—Terence Egan-Wyer; hospital consultants—Henry W. Kolbe, M.D., Harry E. Brown; struct. engrs.—John T. Howell, James F. Goodwin, Harold G. Conger; assoc. struct. engr.—Ricardo Torres G.; archt. of 300-bed hospital—Alston G. Gutteresen—BTS—May, pp. 130-138.
- Rosetti, L. See Giffels & Vallet.
- Routt, Lester W., Archt. and Engr. Lawrence County Memorial Hospital, Lawrence County, Ill.—BTS—May, p. 116.
- Royston, Robert. See Bay Area Style.

## S

- St. Elizabeth Hospital, Dayton, Ohio. Schmidt, Garden & Erikson, archts. Illustration for article, "Tomorrow's Hospitals," by Carl A. Erikson—BTS—May, p. 110.
- St. Joseph's Hospital, Lancaster, Pa. Schmidt, Garden & Erikson, archts. Illustration for article, "Tomorrow's Hospitals," by Carl A. Erikson—BTS—May, p. 111.
- Saarin, Eero. Article, "A Few Thoughts About the Hidden Talent Competition"—Mar., p. 88.
- Schlanger & Hoffberg, Archts.; Reiser & Urbahn, Archts. Island Theater (The), Hamilton, Bermuda—April, pp. 86-91; Tacna Theater, Lima, Peru—April, pp. 92-97.
- Schmidt, Garden & Erikson, Archts. See Illinois Masonic Hospital; Mercy Hospital; Northwestern University Medical Center; Nurses' Home; St. Elizabeth Hospital; St. Joseph's Hospital.
- "School Plan Types, A Cost Study of." Article by Alonzo J. Harriman—BTS—Mar., pp. 111-115.
- "School Planning and School Costs." Article by Alonzo J. Harriman—April, pp. 98-101.
- SCHOOLS. BTS No. 147—Mar., pp. 110-130.
- Schools. Blackwell, Okla.—Mar., p. 130; Brewer School, Maine—Mar., p. 115; Briarcliff School, Seattle, Wash.—Mar., pp. 128-129; Dover School, Seattle, Wash.—Mar., pp. 128-129; Edmonds Grade School, Edmonds, Wash.—Mar., pp. 126-127; Esperance Grade School, Edmonds, Wash.—Mar., p. 127; Fairfax Elementary School addition, Fairfax, Calif.—Jan., pp. 67-75; Memorial High School and Gymnasium, Calais, Me.—Mar., pp. 116-118; Milan School, Mich.—Mar., p. 119; Shoreview School, San Mateo, Calif.—Mar., pp. 120-125.
- Schwartz, Fred L., and William G. Hyberg, Archts. Community Memorial Hospital, Tracy, Calif.—May, pp. 118-119.
- Schweiker and Elting, Archts. House plan featuring revival of kitchen as center of home. Illustration for article, "Home Life and House Architecture," by Arthur McK. Stires—BTS—April, p. 104.
- Scruggs and Hammond. See Lankton, J. Fletcher.
- "Second Thoughts on Radiant Heating." Article by W. P. Chapman and R. E. Fischer—AE—Mar., pp. 133-135.
- Severud, Fred N. See Douglass, Lathrop.
- Shoreview School, San Mateo, Calif. Ernest J. Kump and Mark Falk, archts.—BTS—Mar., pp. 120-125.
- "Show Window Designs to Prevent Glare." Article by Dr. Louis Parnes (text and drawings from *Planning Stores that Pay*)—TSS-AE—Feb., pp. 137, 141, 143.
- Simpson, Robers, Co., Ltd. See Parkin, John B., Assocs.
- Skidmore, Owings & Merrill, Archts. New York University-Bellevue Medical Center, New York, N. Y.—Mar., p. 10. See also "Manhattan House."
- Skip-Floor Corridor, The. Article, "The Skip-Floor Corridor Serves a Five-Fold Purpose," by Julian Whittlesey—BTS—Feb., pp. 124-128.
- Skip-Floor planning. See Eastgate Apartments.
- "Skyhooks Raise Roof, Cut Costs." Article by J. P. Allinson (Youtz System)—AE—Jan., pp. 121-123.
- Smith, Raymond F., Archt.; A. E. Swank Jr., Assoc. Delman Theater, Dallas, Tex.—Jan., pp. 84-87.
- Smyth, J. G. Jr., Archt. Galiad County Hospital, Galiad, Tex.—BTS—May, p. 114.
- "So You're Going to Mexico." Article by Susanne Wasson-Tucker—Mar., pp. 100-105.
- Solar Heat. See "M.I.T. Builds Solar-Heated House"; "Test House Heated Only by Solar Heat."
- Spackler, Herman. See Beelman, Claude.

Sporn, Philip, and Ambrose, E. R. Article, "Heat Pump Undergoing Tests in Five Houses"—AE—May, pp. 140-144, 182, 184.

Station KHJ, Hollywood, Calif. Radio and television station. Claude Beelman, archt.; Herman Spackler, assoc.—BTS—June, p. 139.

Station KWKC, Abilene, Tex. Radio station. Hughes & Olds, archts.—BTS—June, p. 141.

Station WBZ, Boston, Mass. Radio and television station. Architectural Dept., Westinghouse Electric and Manufacturing Co., Archts.—BTS—June, pp. 134-135.

Station WHAM, Rochester, N. Y. Radio and television station. Kaelber & Waasdorp, archts.—BTS—June, p. 140.

Station WICU, Erie, Pa. Radio and television station. Nelson & Goldberg, archts. & engrs.—BTS—June, p. 138.

Stegman, Paul. See Arhus University.

Stires, Arthur McK. Article, "Home Life and House Architecture"—BTS—April, pp. 103-107.

Stoddard, George Wellington, and Assocs., Archts. and Engrs. Briarcliff School, Seattle, Wash.—BTS—Mar., pp. 128-129; Dover School, Seattle, Wash.—BTS—Mar., pp. 128-129.

Stonorov, Oscar, Dsnr. Block garden, Luzerne St., Philadelphia, Pa.—Feb., p. 24.

Stowell, Kenneth K. Editorials: "Art in Our Time"—Jan., p. 67; "Codes, Costs and Standards"—Feb., p. 83. "Designers Extraordinary"—June, p. 85; "Mind Reading?"—April, p. 85; "Revelation by Competition"—Mar., p. 85; "We Believe"—May, p. 85.

Strobel and Salzman. See Douglass, Lathrop.

Strock, Clifford. Article, "Progress in House Heating Equipment"—AE—April, pp. 135-138.

Structural Steel, Fireproofing. Article, "Fireproofing Structural Steel with Vermiculite Plaster," by Vermiculite Institute—TSS-AE—April, pp. 151, 153.

Stubbins, Hugh Jr., Archt. House, Concord, Mass.—BTS—April, pp. 114-117; house plan featuring segregation of children's quarters—illustration for article, "Home Life and House Architecture," by Arthur McK. Stires—BTS—April, p. 105.

Swank, A. E. Jr. See Smith, Raymond F.

## T

Tacna Theater, Lima, Peru. Schlanger & Hoffberg, archts.; Reisner & Urbahn, archts.—April, pp. 92-97.

"Tamalpais House," north of San Francisco, Cal. Henry Hill, dsnr.; Eckbo, Royston & Williams, landscape archts.—June, pp. 96-101.

"Television Producing Plant, The." Article by Elwell—BTS—June, p. 133.

Television station for teaching, experimental, Sands Point, L. I., N. Y. Office of Naval Research, U. S. Navy, archts.—BTS—June, pp. 136-137.

Television stations. See Radio and television stations.

Telkes, Dr. Maria. See "Test House Heated Only by Solar Heat."

"Test House Heated Only by Solar Heat." Dr. Maria Telkes residence, Dover, Mass. Eleanor Raymond, archt. Miss Amelia Peabody, sponsor—AE—Mar., pp. 136-137.

Theaters. Delman Theater, Dallas, Tex.—Jan., pp. 84-87; Island Theater (The), Hamilton, Bermuda—April, pp. 86-91; Tacna Theater, Lima, Peru—April, pp. 92-97.

Thiry, Paul, Archt. House plan featuring segregation of children's quarters. Illustration for article, "Home Life and House Architecture," by Arthur McK. Stires—BTS—April, p. 105.

Tibbals-Crumley, Musson, Archts. See "Heat Pump Undergoing Tests in Five Houses."

"Tomorrow's Hospitals." Article by Carl A. Erikson—BTS—May, pp. 109-112.

Torres G., Ricardo. See Roosevelt Medical Center.

Tri-Level Home. Lumber Fabricators, Inc., design for three-bedroom house for mass production—Mar., p. 166.

Turner, George P., Dsnr. House for Mr. and Mrs. George Turner, La Canada, Calif.—Mar., pp. 106-109.

## U

University buildings. See Arhus University; Alaska,

University of; Lamont Library.

## V

Vermiculite Institute. Article, "Fireproofing Structural Steel with Vermiculite Plaster"—TSS-AE—April, pp. 151, 153.

Viessman, Warren. See Roosevelt Medical Center.

Violich, Francis. See Bay Area Style.

Vozenilek, Jiri, Archt. Apartment house, Zlin, Czechoslovakia—Jan., p. 96.

## W

"Wage Stabilization Stimulates Building." Article—Feb., pp. 94-95.

Walker, Ralph Thomas. Election as president of American Institute of Architects at eighty-first national convention, Houston, Tex.—April, p. 10; May, pp. 86-91.

Wasson-Tucker, Susanne. Article, "So You're Going to Mexico"—Mar., pp. 100-105.

"Water-Repellent Preservatives for Wood." Article by F. L. Browne—AE—Mar., pp. 131-132.

"Water-Repellent Preservatives Work on Wood." Article by Harlon H. Edwards—AE—Feb., pp. 131-134.

Waterman Building, Mobile, Ala. Platt Roberts, archt.; O. W. Long Jr. and A. B. Benson, assoc. archts.—Jan., pp. 108-111.

Waterman Steamship Corp. See Waterman Building.

"We Believe." Editorial by Kenneth K. Stowell—May, p. 85.

Webb, Hartwell M. See Roosevelt Medical Center.

Weren, Edward Chase, Dsnr. Third Prize design of community center for Hidden Talent Competition; ARCHITECTURAL RECORD and Museum of Modern Art, co-sponsors—Mar., p. 91.

Westinghouse Electric and Manufacturing Co., Architectural Dept., Archts. Radio and Television Station WBZ, Boston, Mass.—BTS—June, pp. 134-135.

White House. See "Rebuilding the White House."

Whiting, Edmund J., Archt.-in-Charge. Roosevelt Medical Center, Guatemala. Samuel T. Drew, dir. of Institute of Inter-American Affairs in Guatemala (for complete listing of archts., engrs. and assocs., see Roosevelt Medical Center)—BTS—May, pp. 130-138.

Whittlesey, Julian. Article, "The Skip-Floor Corridor Serves a Five-Fold Purpose"—BTS—Feb., pp. 124-128.

Wiggs, G. Lorne. Article, "Prefabricated Floor Panels for Large Buildings" (K-W System)—AE—Jan., pp. 117-120.

Williams, Edward. See Bay Area Style.

Wills, Royal Barry. Article, "Confessions of a Cape Codder"—BTS—April, pp. 132-134.

Windows, Modular Design Data for Wood. TSS-AE—Mar., pp. 138, 143, 145.

Wood preservatives. See "Water-Repellent Preservatives for Wood"; "Water-Repellent Preservatives Work on Wood."

Woodwork. See Cabinetwork Details.

Worcester, Thomas Inc. See Eastgate Apartments.

Wright, Frank Lloyd, Archt. Recipient of Gold Medal at eighty-first annual convention of American Institute of Architects, Houston, Tex.—May, pp. 86-91; The New Theater, Hartford, Conn. Project of Paton Price and Assocs. Model exhibited by Museum of Modern Art—May, p. 156.

Wurdeman & Becket, Archts. House plan featuring kitchen as center of home. Illustration for article, "Home Life and House Architecture," by Arthur McK. Stires—BTS—April, p. 104; General Petroleum Co. office building, Los Angeles, Calif.—April, p. 170.

Wurster, William Wilson. See Bay Area Style.

Wurster and Bernardi, Archts. House plan featuring master bedroom as private apartment. Illustration for article, "Home Life and House Architecture," by Arthur McK. Stires—BTS—April, p. 106.

## Y

Youth System. See "Skyhooks Raise Roofs," Cut Costs."

## Z

Ziegele, John N. See Lankton, J. Fletcher.

## BOOKS REVIEWED

AUDELS HOUSE HEATING GUIDE. By Frank D. Graham—April, p. 28.

BUILDING FOR MODERN MAN: A SYMPOSIUM. Edited by Thomas H. Creighton—May, p. 28.

CHURCH BUILDER, THE. By Elbert M. Conover—June, pp. 28-30.

CHURCHES: THEIR PLAN AND FURNISHING. By Peter F. Anson—Jan., p. 28.

CHURCHES ARE BURNING. By National Fire Protection Association—May, p. 28.

CONCERNING TOWN PLANNING. By Le Corbusier—Mar., p. 28.

DESIGN OF STEEL BUILDINGS, THIRD EDITION. By Harold D. Hauf and Henry A. Pfisterer—June, p. 28.

DURHAM CATHEDRAL. Edited by Paul Wengraf—May, pp. 28, 30.

ELEMENTARY STRUCTURAL PROBLEMS IN STEEL AND TIMBER, THIRD EDITION. By C. R. Young and C. F. Morrison—June, p. 28.

ENGINEERING THE NEW AGE. By John J. O'Neill—May, p. 28.

GEO-METRIC VERSE. By Gerald Lynton Kaufman—Mar., p. 28.

GUIDE TO THE ART OF LATIN AMERICA, A. By Smith and Wilder—Mar., p. 28.

HEATING AND VENTILATING BUYER'S DIRECTORY. Edited by Clifford Strock—May, p. 30.

HISTORY OF CAST IRON IN ARCHITECTURE, A. By John Gloag and Derek Bridgewater—April, p. 28.

HOME FURNISHING. By Anna Hong Rutt—Mar., p. 30.

HOSPITAL BUILDING, THE: SEMINAR ADDRESSES OF THE 1947 A.I.A. CONVENTION. Compiled and edited by Walter A. Taylor—Mar., p. 30.

HOUSES FOR CANADIANS. By Humphrey Carver, A.R.I.B.A.—Feb., p. 30.

HOUSING AND TOWN AND COUNTRY PLANNING. By the Department of Social Affairs, United Nations—April, p. 28.

INDUSTRIAL ARTS DESIGN. By William H. Varum—May, p. 30.

INTRODUCTION TO REGENCY ARCHITECTURE, AN. By Paul Reilly—April, p. 30.

INTRODUCTION TO VICTORIAN ARCHITECTURE, AN. By Hugh Casson—April, p. 30.

1948 STORE MODERNIZATION: CLINICS AND FORUMS AT THE SECOND INTERNATIONAL STORE MODERNIZATION SHOW, NEW YORK CITY, JULY, 1948. Edited by Store Modernization Show, Inc.—Jan., p. 28.

PARK AND RECREATION STRUCTURES. By the National Park Service—Feb., p. 30.

PLANNING STORES THAT PAY. By Dr. Louis Parnes—Feb., p. 28.

PLANNING THE MODERN CITY: VOL. I. By Harold MacLean Lewis—Mar., p. 28.

PLANNING THE MODERN CITY: VOL. II. By Harold MacLean Lewis—Mar., p. 28.

PLANNING THE NEIGHBORHOOD. By the American Public Health Association Committee on the Hygiene of Housing—Mar., p. 28.

PLANNING THE UNIVERSITY LIBRARY BUILDING. Edited by John E. Burchard—June, p. 28.

PUBLIC HEALTH ENGINEERING. By Earle B. Phelps (and collaborating authors)—Mar., p. 28.

RADIANT HEATING. By Richard Woolsey Shoemaker—April, p. 30.

ROOF BOSSES IN MEDIEVAL CHURCHES. By C. J. P. Cave, M.A., F.S.A.—June, p. 212.

SAFETY FOR THE HOUSEHOLD. By the U. S. Department of Commerce and the National Bureau of Standards—June, p. 30.

SMALL HOUSE CARPENTRY. By Training-Thru-Sight Associates, Lee Frankl, Director—April, p. 28.

SURGING CITIES: A SECONDARY SCHOOL TEXTBOOK IN TWO PARTS (PART I, URBAN PLANNING PROBLEMS AND SOLUTIONS; PART II, GREATER BOSTON ACTS FOR TOMORROW). By Theodore T. McCroskey, Charles A. Blessing, and J. Ross McKeever—Jan., p. 30.

SWEDEN PLANS FOR BETTER HOUSING. By Leonard Silk—Feb., pp. 28, 30.

TRANSCRIPT OF THE INSTITUTE ON HOSPITAL PLANNING: A COLLECTION OF LECTURES PRESENTED BY HOSPITAL CONSTRUCTION AUTHORITIES. Edited by the American Hospital Association—Jan., pp. 28, 30.