

# BUILDING NEWS

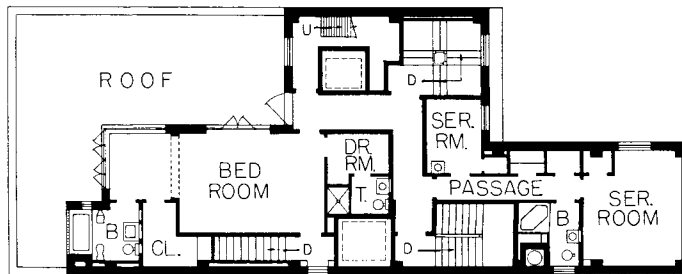

*Donatas Andrusis*

ARCHITECTURAL  
RECORD

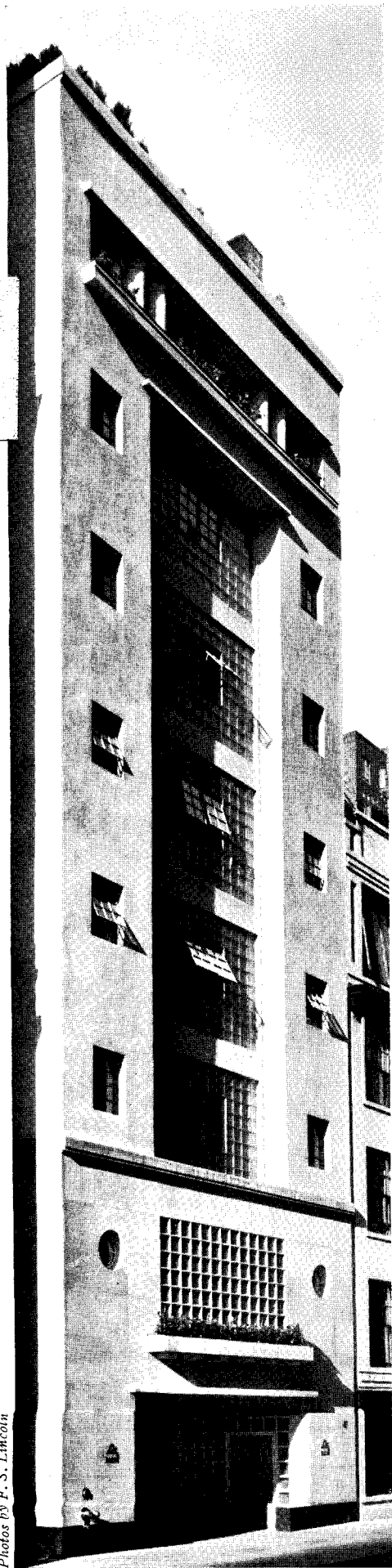

Ninth Floor

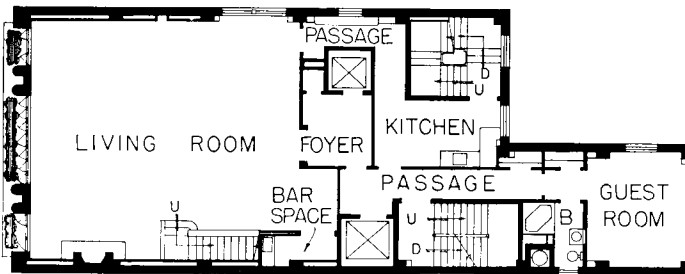

Eighth Floor

Seventh, Sixth and Fifth Floors are lofts, designed for renting to commercial or service industries; Fourth Floor is used by owner for manufacturing hats.

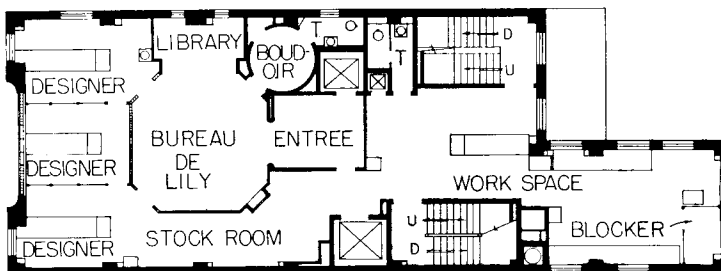

Third Floor

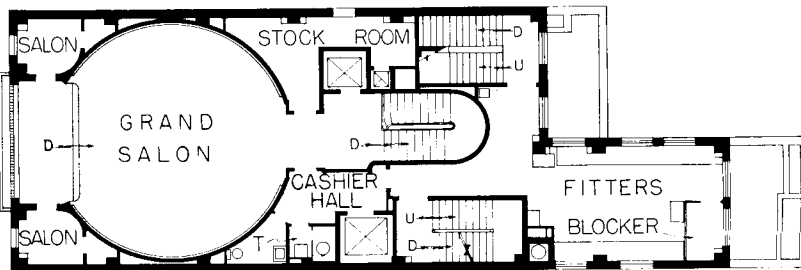

Second Floor

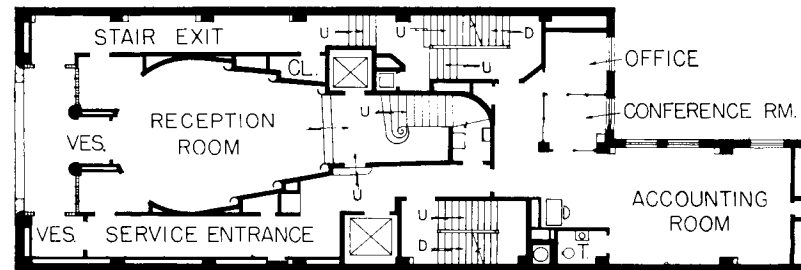

First Floor

OWNER'S APARTMENT

DESIGN, SALES AND OFFICES



Detail, Main Entrance

## NEW YORK: MILLINER BUILDS MULTI-STORY ESTABLISHMENT

SHREVE, LAMB & HARMON, GEORGES LETELIE, Architects

ROBSJOHN-GIBBINGS, LTD., Decorators

DESIGNED primarily to house an exclusive millinery establishment, the new building for Lilly Daché in New York City consists of three units: four floors for the design, manufacture and sale of women's hats, a penthouse apartment for Mme. Daché and three loft floors to be rented. This multiple use posed a problem for the designers, especially in the matter of circulation. A narrow lot, together with the owner's requirements for large public rooms at each level of the retail area, pushed the elevators and stairways to the back. These are arranged so that the smaller elevator serves only the shop and apartment, while the larger one serves all floors from a public lobby; additional vertical circulation is provided by the "grand" stairway between first and second floors of the shop and another between penthouse floors.

The shop plan is an interesting example of merchandising design where "class appeal" is a very essential part of the sale. The public areas are as little as possible like those of the average store: counters, display cases, adding machines—all are carefully hidden from the customer. Moreover, the salesrooms are arranged for the progressive elimination of the customers, so that only the hardiest reach Mme. Daché's Bureau on the third floor. Serving these public areas, however, is a compact and efficient system of workrooms, stockrooms, dumb-waiters and offices.

The structure is steel-framed and fireproof. The first two floors are finished with Indiana limestone on brick and hollow tile back-up; above this level the finish is stucco. All floors are completely air-conditioned.

# DACHÉ BUILDING

Photos by F. S. Lincoln



**RECEPTION ROOM:** Floors: Montana travertine. Rugs: horsehide. Walls: beige with wax finish. Furnishings: settee, birch, upholstered in black buffalo hide; desk, birch with black buffalo-hide top; chair, same as settee; statue, carved wood, Ming dynasty. Stair carpet, beige broadloom. Indirect lighting (detail below) obtained by vertical covered recesses in the splayed walls.

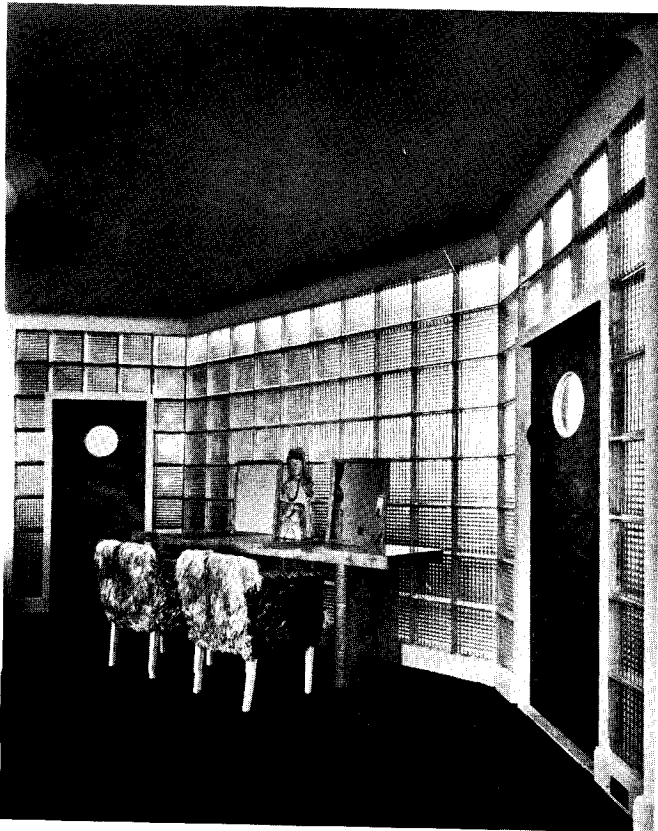

**BUREAU DE LILLY:** The owner's private office on the third floor near design department. Walls: glass block; beige plaster. Carpet: bronze-green broadloom. Ceiling: beige. Doors: stretched hide, dyed bronze-green. Furniture: table, hawood veneer; chairs, upholstered in Tibetan wolf.

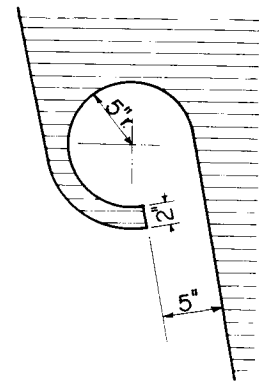

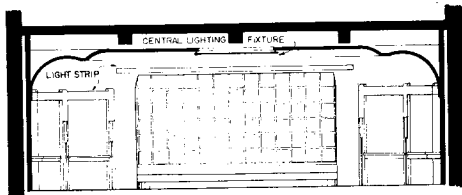

Section of Salon

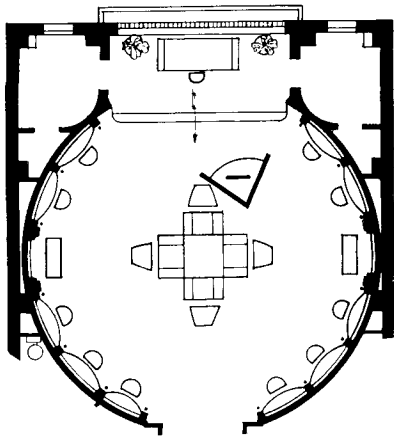

Plan of Salon

**SALON:** No merchandise displayed here; customers sit at mirrored recesses and at a desk in the center of the room. Floor: polished cork. Rugs: horsehide. Walls: mirrors, and beige plaster. Curtains: black metallic gauze. Door drapery: rough spun fabric with gold thread. Furnishings: exposed woodwork, acacia; chairs, hand-woven Balinese fabric; settee, striped Indian fabric.

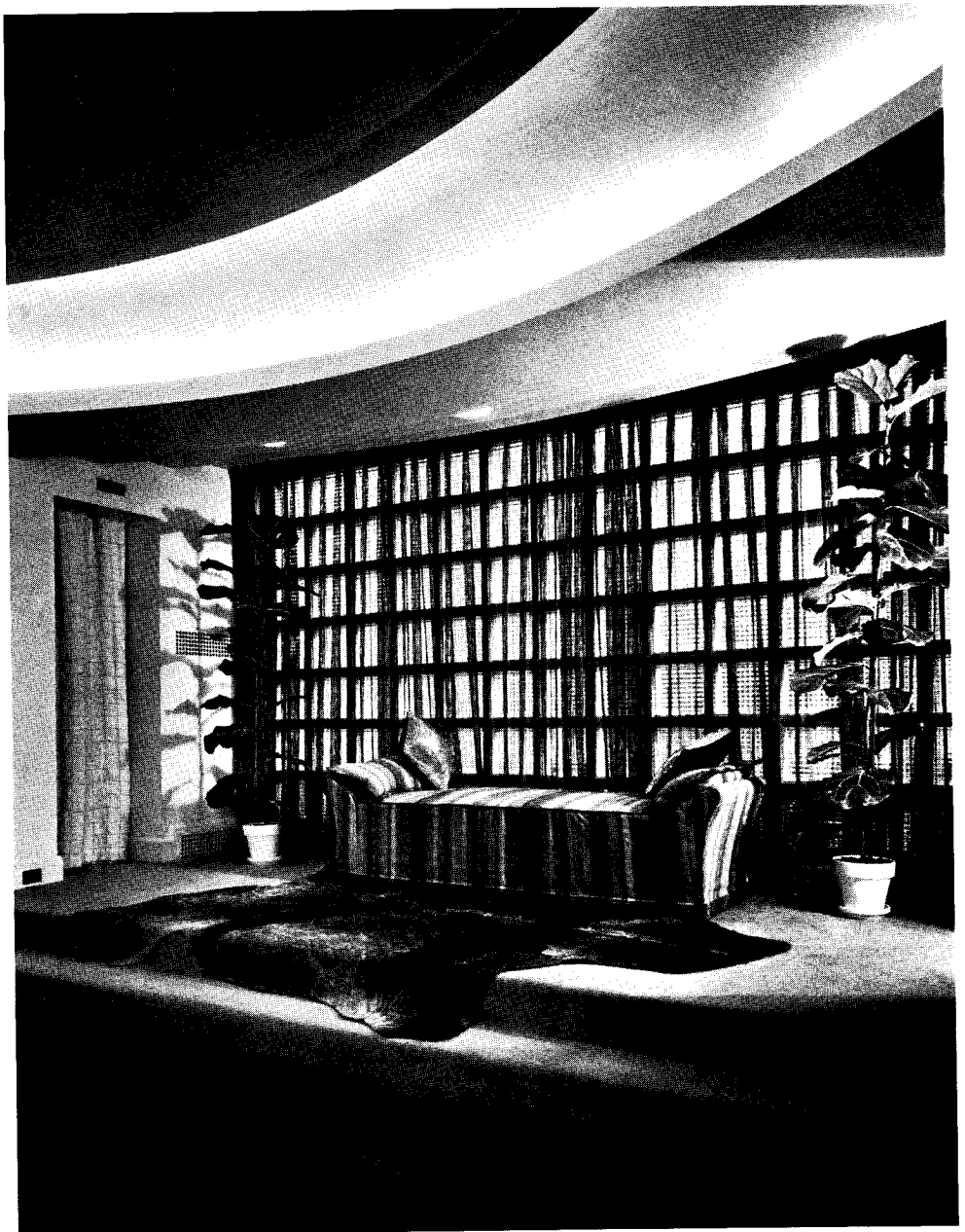

VIEW NO. 1: Toward window, showing entrance to small salon

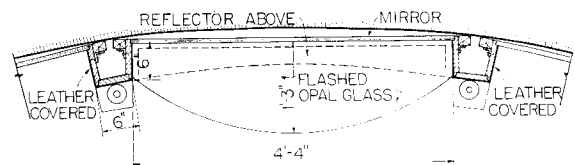
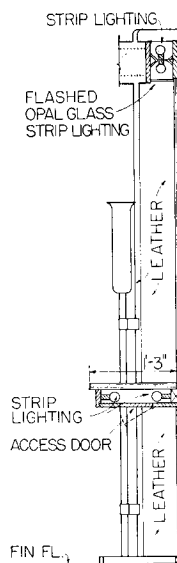
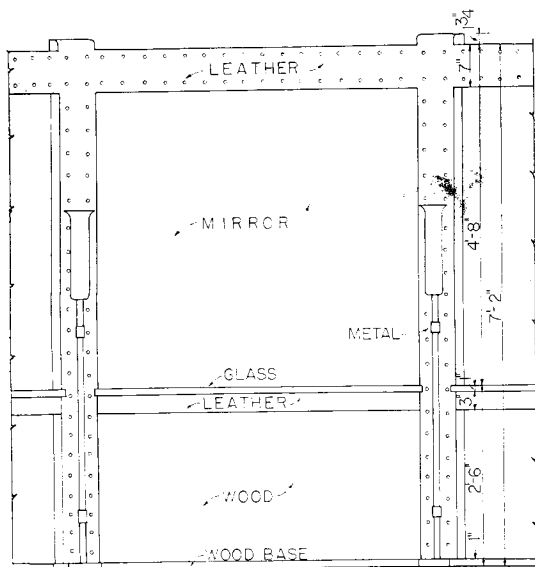

Lighting in the salon is based on the no-glare principle used in motion-picture photography. The mirrored recesses, framed in flogged leather with brass studs, are lighted indirectly by torcheres of frosted crystal at the side. There is a large ceiling fixture in addition.

# DACHÉ BUILDING

Photos by F. S. Lincoln



VIEW NO. 1: Looking down stairs towards fireplace group and street front, stone- and mirror-faced fireplace at left. VIEW NO. 2 (right): Looking towards dining group, entrance lobby and bar under stairway.

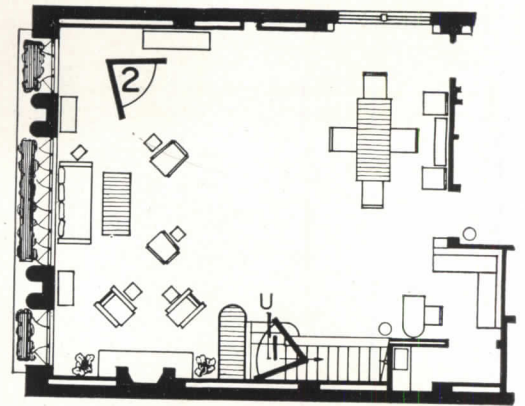

LIVING ROOM: Carpet, brown and beige pebble tuft. Walls: beige. Draperies: white rough spun fabric with gold thread; glass curtains, white metallic gauze. Furnishings: fireside group, chairs of acacia wood upholstered with Chinese chintz; other woodwork, rosewood; dining group, rosewood; chairs upholstered in orchid green rough silk.



VIEW NO. 3: Bedroom, looking towards Mme. Daché's dressing room

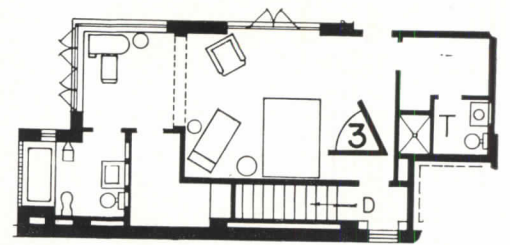

BEDROOM: Opening off the owner's bedroom are two bath-dressing rooms—left, Mme. Daché's; right, her husband's. Floor: marble in dressing room, with monkey fur rug. Carpet: beige broadloom. Walls: beige. Curtains: rose-beige in bedroom; green in dressing room. Furnishings: chair, green plush; bedspread, rose chiffon velvet; chaise lounge, covering of fox furs.



## NEW SHOPS MAINTAIN CHARACTER OF OLD BUILDINGS

EDWARD I. SHIRE  
WALTER RAYMOND  
Associated Architects



THE CONVERSION of the ground floors of town houses into shops is not a novel operation in itself. But in this recent job in New York's East Fifties, the architects have carried through the shift without the usual changing of the essential character of the original buildings. Taking three adjoining Georgian houses, the architects performed essentially the same operation—removed all existing partitions, lowered the floors to sidewalk level, eliminated the areas and rebuilt the first-floor facade up to the existing base mold. Shown here (above and left) is the center shop for Raymond and Raymond, print sellers, for whose interior Walter Raymond was the designer; details of this shop appear overpage.

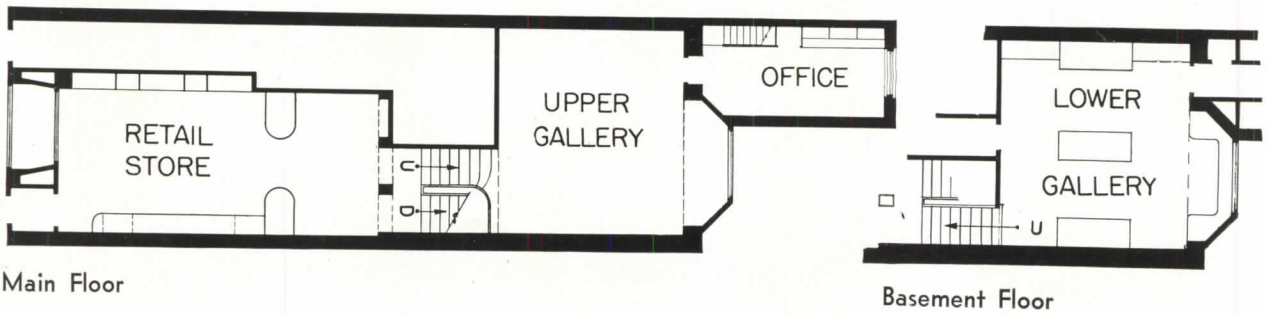

PLANNING the layout of the Print Shop involved a number of problems: provision of space not only for the sale of prints, but for their proper display; also provision of space, easily accessible but separated from sales and display activity, for exhibition, and for undisturbed selection of frames. The successful solution adopted by Mr. Raymond—who is responsible not only for the planning but for the furnishings and fixtures as well—is the loca-

tion of the sales department in the open space at the front of the store, with exhibits arranged on the upper gallery, and the framing department on the lower gallery. The upper gallery also includes facilities for the sale of complete portfolio items, and the lower gallery permits selection of inexpensive reference material in addition to frames. The neutral color scheme used in the shop affords a good background for picture display and is not distract-



# PRINT SHOP

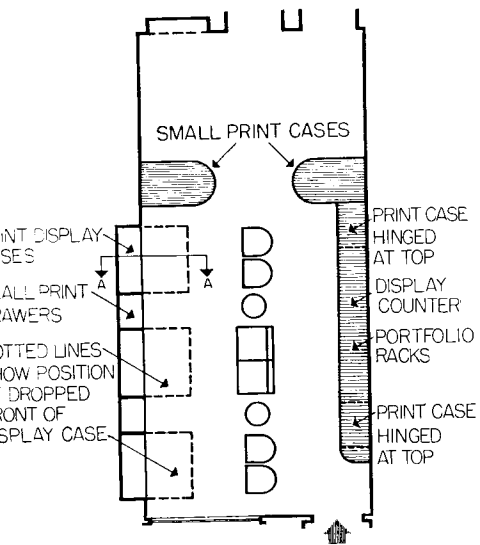

Plan of main sales area (above) allows ample room for circulation as well as storage and display of a very large library of prints of all shapes and sizes. All display is arranged for customer's convenience.

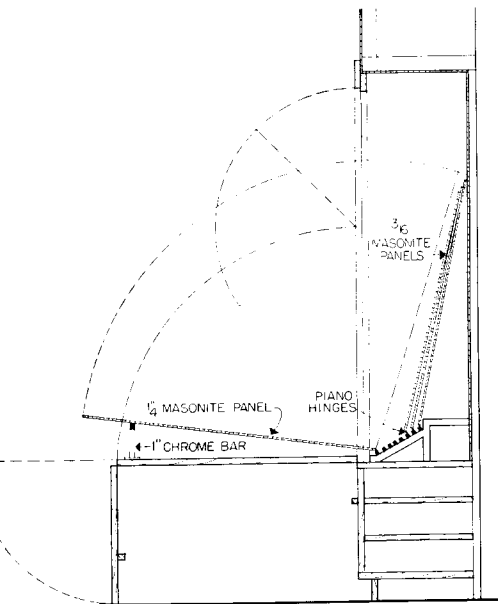

Most interesting feature is this display case for very large prints, design of which the owner has patented. Open, (extreme right) it provides ideal support and lighting for their display; closed, (left) it provides dust- and crush-proof storage.

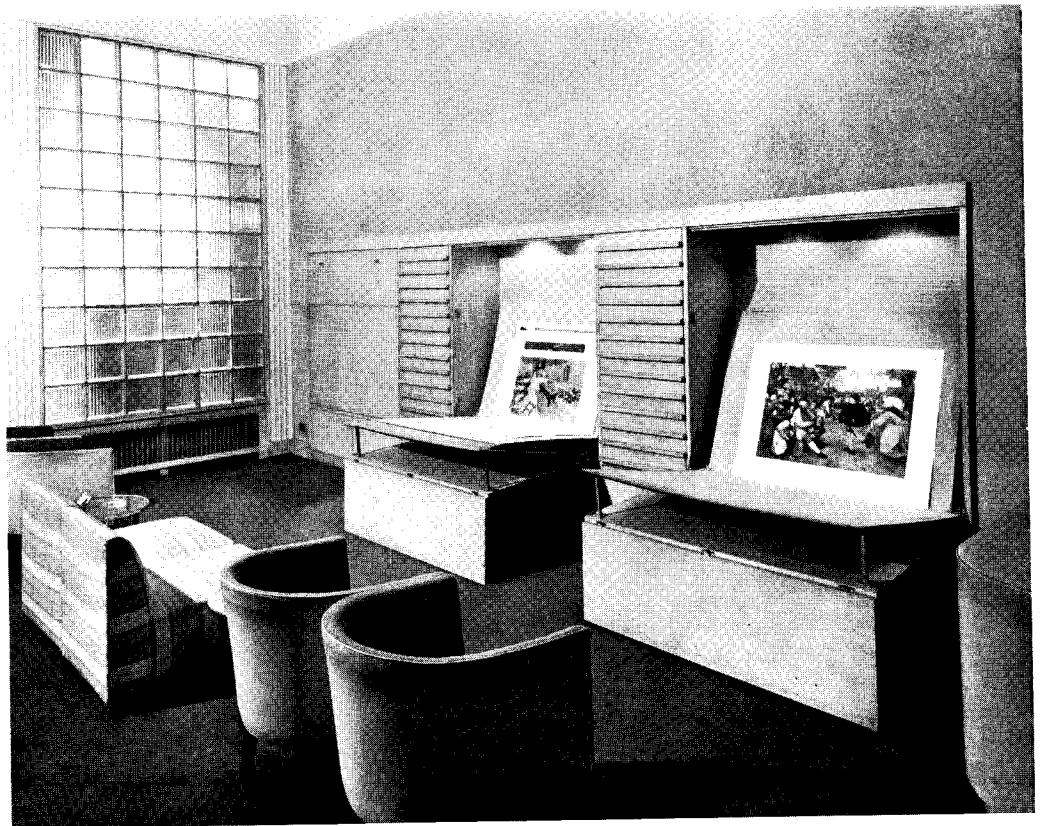

ing to the visitor. Walls are covered in natural monk's cloth; woodwork generally is light-gray. The ceiling presents the same tone as the walls although slightly tinted with rose. The carpet is dark-plum in color.

Recessed lighting fixtures throughout were designed by Corrubia. The complete installation, including furnishings and the specially designed display fixtures, cost \$10,000.

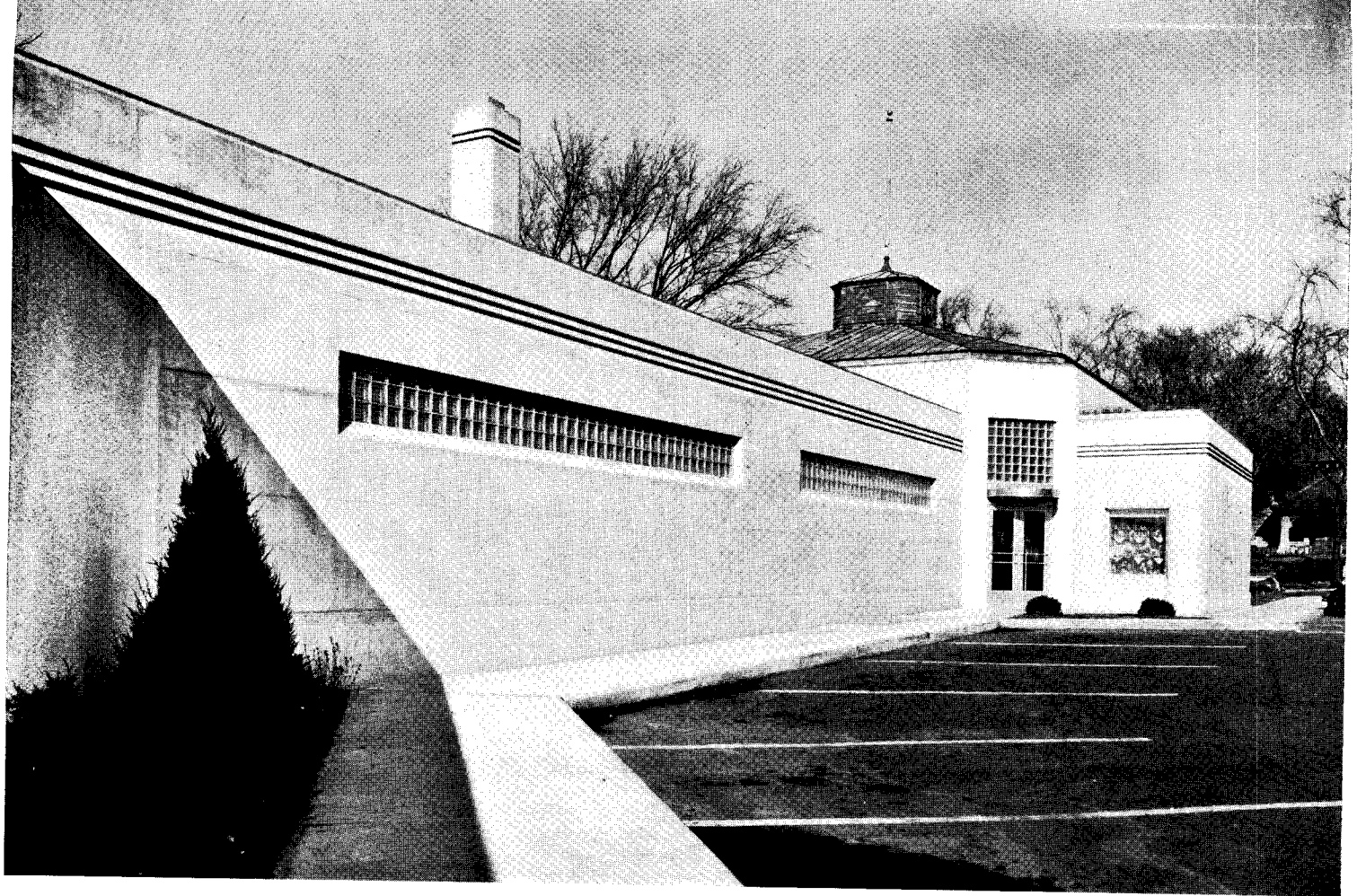

Photos by Tyner-Murphy

# PHONE AND AUTO DICTATE NEW DESIGN IN WESTERN GROCERY

EDWARD W. TANNER

Architect for J. C. Nichols Investment Co.

THE FOOD SHOP for Wolferman's in Kansas City, Missouri, combines a de luxe sales area with extensive provision for handling of telephone orders. Located in a residential section of the city, the shop transacts 75% of its business over the telephone. For the remaining 25% who prefer to hand-pick their groceries, the shop provides a parking lot on which open two of its three doorways. The orderly arrangement of products in alcoves opening off the center of the salesroom (see next page) permits an open space for special displays, and for the order desk. A corridor connects the salesroom with the order-filling room and its adjuncts—meat shop, refrigerator rooms, bakeshop.

To handle telephone orders, a fairly elaborate apparatus is required—a routing room and shipping dock and, adjoining them, the receiving dock with a chute leading to the basement, from which point incoming supplies are distributed. In addition to storage space, the basement contains rooms for refrigerator equipment, boiler, and mechanical air-conditioning equipment. (Provision for future complete air conditioning of the building has been made in the duct-work used throughout.) Lunch and rest rooms for employes and customers' toilet rooms are also situated in the basement. On the mezzanine floor is the manager's office, reached by a cast-iron spiral stair near the bakeshop.

The entire building is constructed of reinforced concrete. Exterior walls were poured in plywood forms, the placing of which was carefully studied, and were not finished in any way after removing the forms. Interior walls are plaster on metal lath. The store relies mainly on artificial light, using the small plate-glass windows for display only. Glass brick panels above the doorways, and along the side walls of the order room, according to the architect, were placed above sight level to avoid "the unpleasant sensation of trying to see through them."

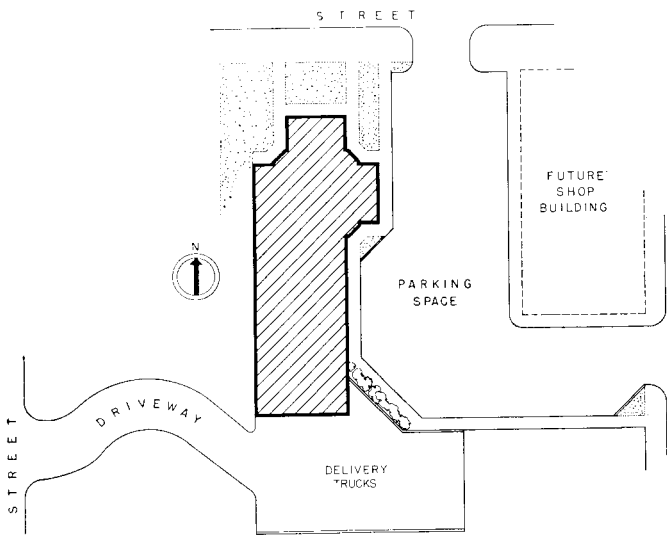

**PLOT PLAN:** Although built on a corner lot, the store is so located that the actual corner can later be developed for shops more dependent on pedestrian shoppers.

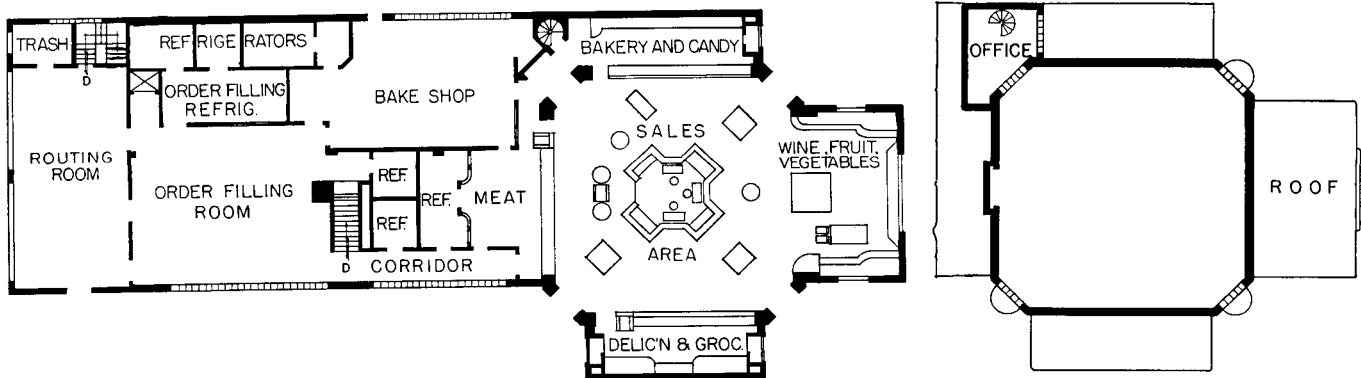

First Floor

Mezzanine Floor

# WOLFERMAN'S SHOP



Photos by Tyner-Murphy

In the center of the main salesroom is the octagonal booth which serves as order-taking desk. Opening off this area on all four sides are alcoves where products, conveniently classified and segregated, are displayed and sold. Floors: salesroom, black and white tile, except in alcoves where

wood is used back of the counters; bakeshop, white tile. Walls: salesroom, 9-foot panels of Oriental walnut; off-white plaster; bakeshop, white tile. Ceiling: dome, acoustical plaster; alcoves, Acousti-Celotex. Doors and frames: aluminite aluminum. Lighting: recessed Holophane lights.



# FINLAND BUILDS AN INTEGRATED TRANSPORTATION CENTER

O. FLODIN  
E. SEPPÄLÄ  
Architects

THE NEW RAILWAY station at Tampere, principal industrial town of central Finland, stands on the site of an old wooden station which, to allow uninterrupted traffic, was demolished by sections as the new building was erected. Office work and passenger traffic was handled in the old building until that portion of the new building was finished. The final stage consisted of the erection of restaurant, cafe and tower. The design of O. Flodin and E. Seppälä, chosen by competition, did not originally include the tower. That was added by the builder, the Finnish State Railways, for commercial and decorative reasons.

The planning of the Tampere station is more complex than its American counterpart in that it houses the division offices of the railroad, sleeping car service, post and telegraph—all state-owned enterprises. Also operated in connection with the station is a system of motorbus lines which serve as feeders for the surrounding area. These transportation and communication services have been skillfully integrated into a center which houses not only the offices but a portion of the personnel.

Situated on an open square at the crest of a slight hill, the station gains in effect by being silhouetted against the sky. Because vehicular traffic across the square must go through a tunnel under the train yards, the level of the square was lowered, and the main entrance located a floor below the platform level.



Foto Koos

Exterior finish of the station is red face brick. The tower and exterior trim is of concrete, protected with a mineral paint.

Front Elevation

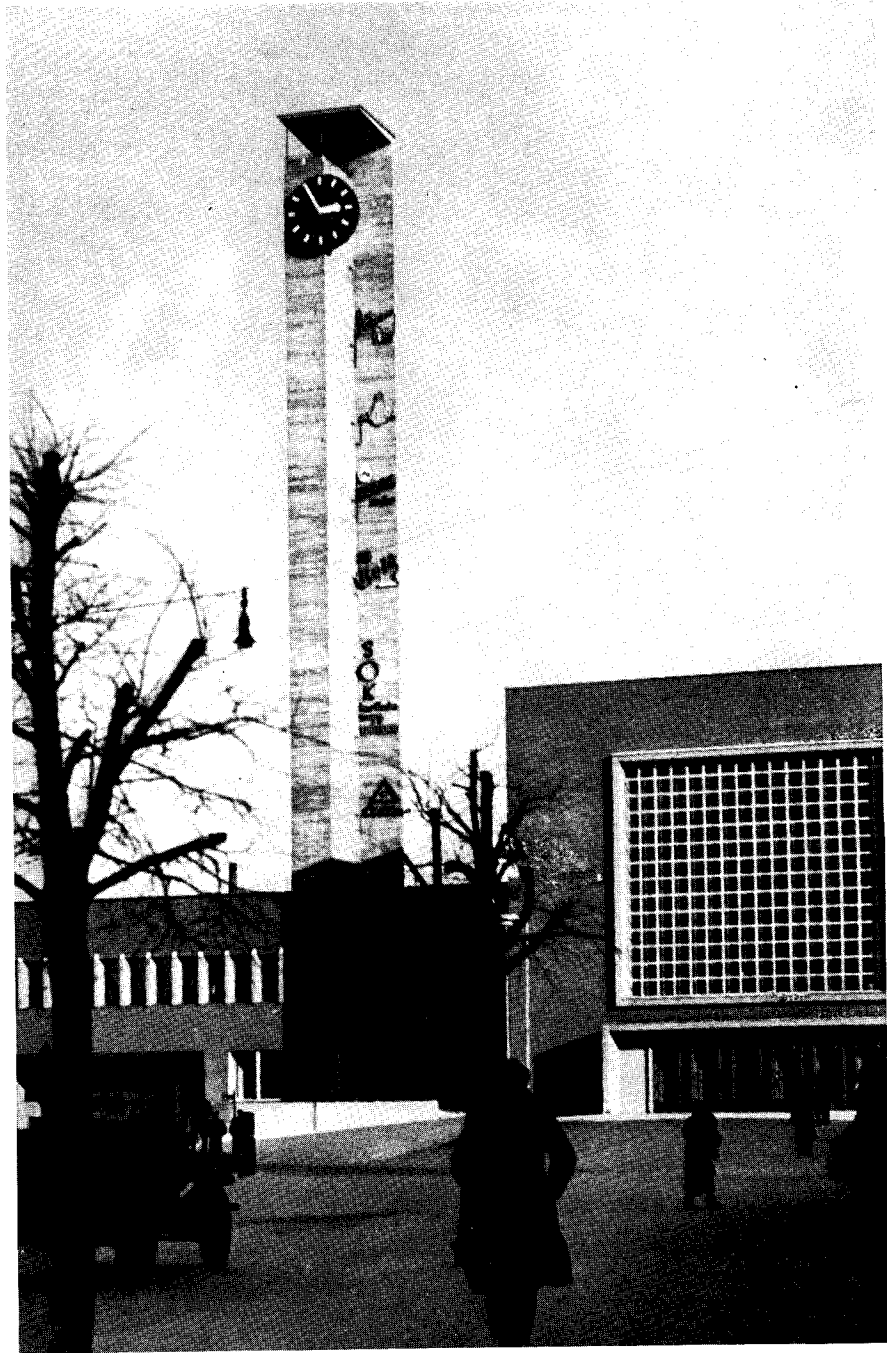
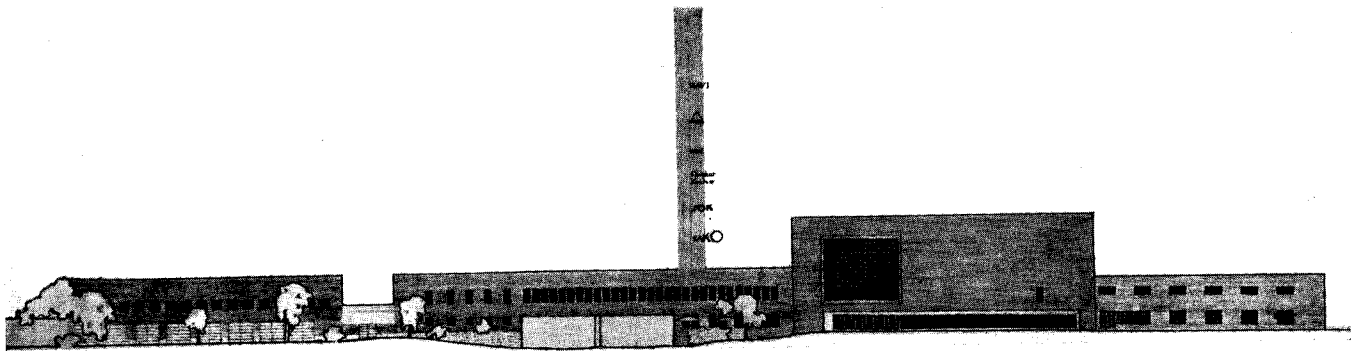

# FINNISH STATION

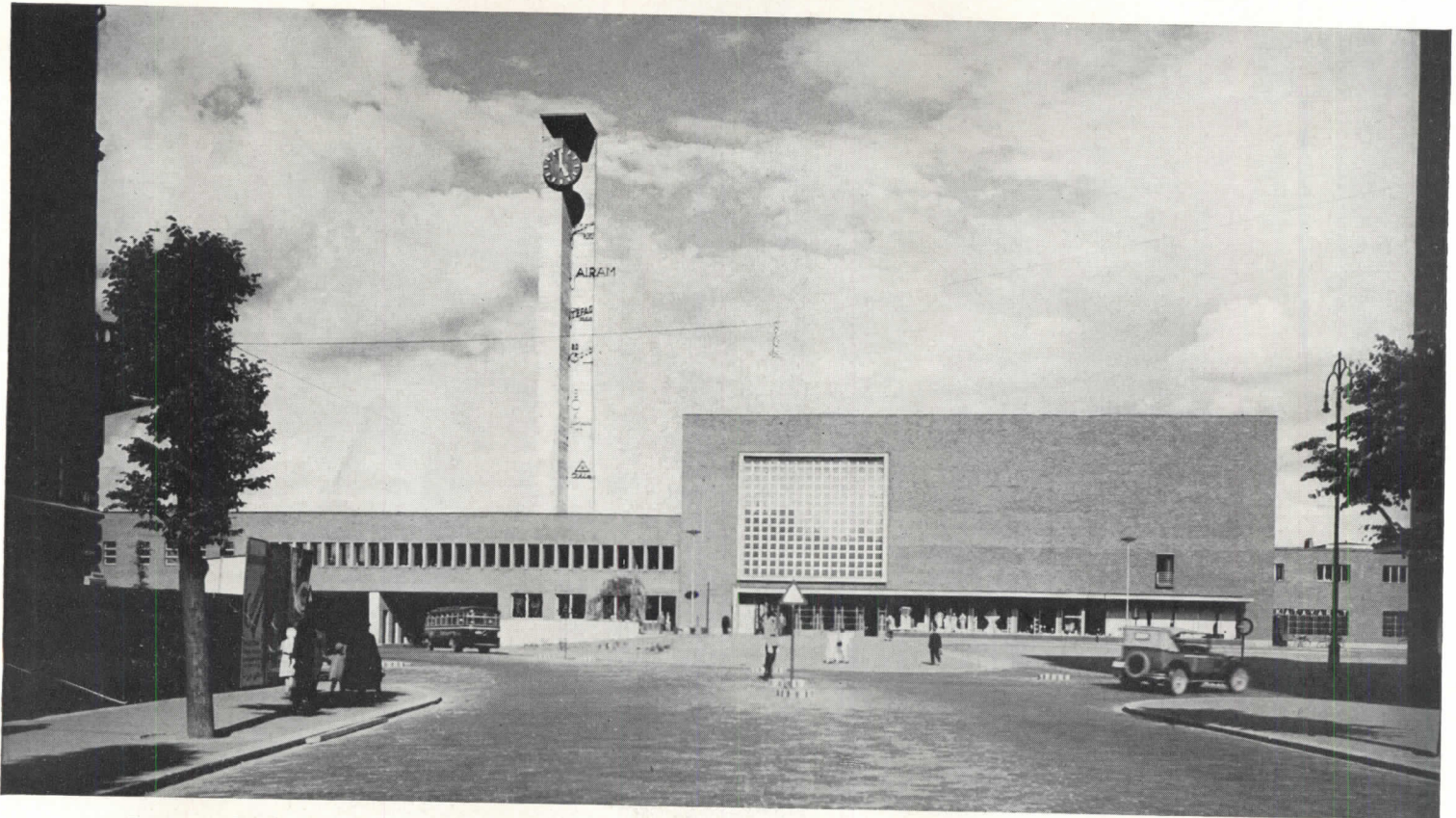

Entrance front, with vehicular tunnel at left

Photos by Roos

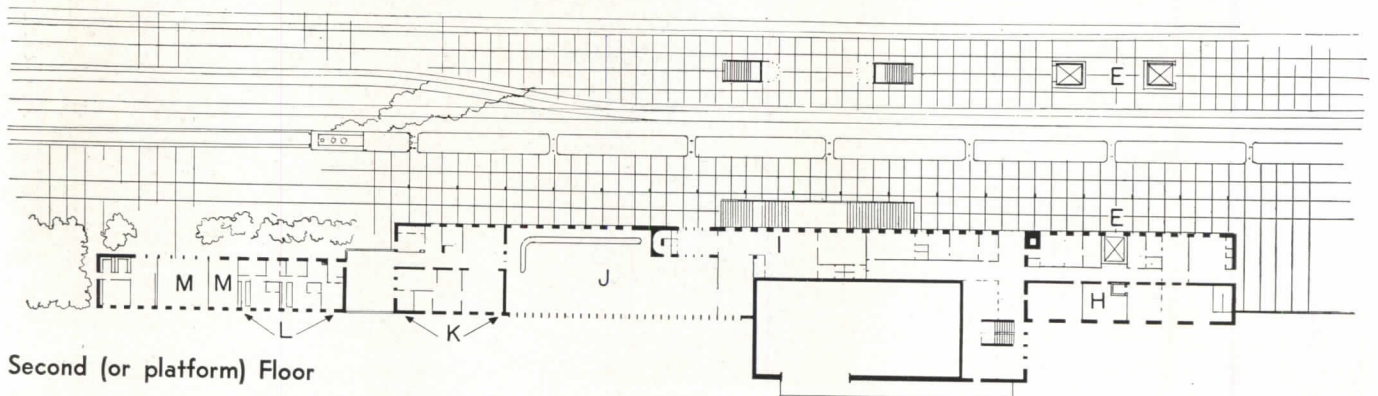

Second (or platform) Floor

- A. Main Waiting Room
- B. Cafe and Terrace
- C. Checkroom and Luggage
- D. Male and Female Toilets
- E. Freight and Passenger Elevators
- F. Cafe Staff Quarters
- G. Motorbus Garage
- H. Telegraph and Mail
- I. Second Floor Waiting Room
- J. Large Restaurant
- K. Kitchen, Pantries, etc.
- L. Sleeping Car Staff Quarters
- M. Electric Baggage Trucks

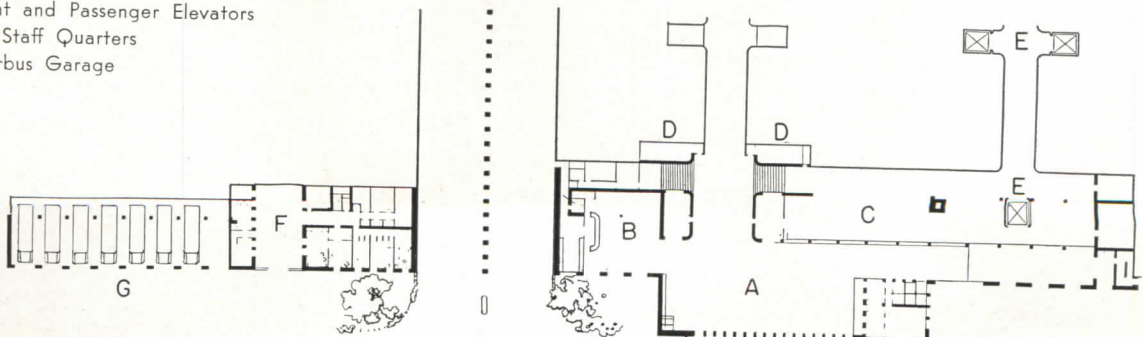

First (or entrance) Floor

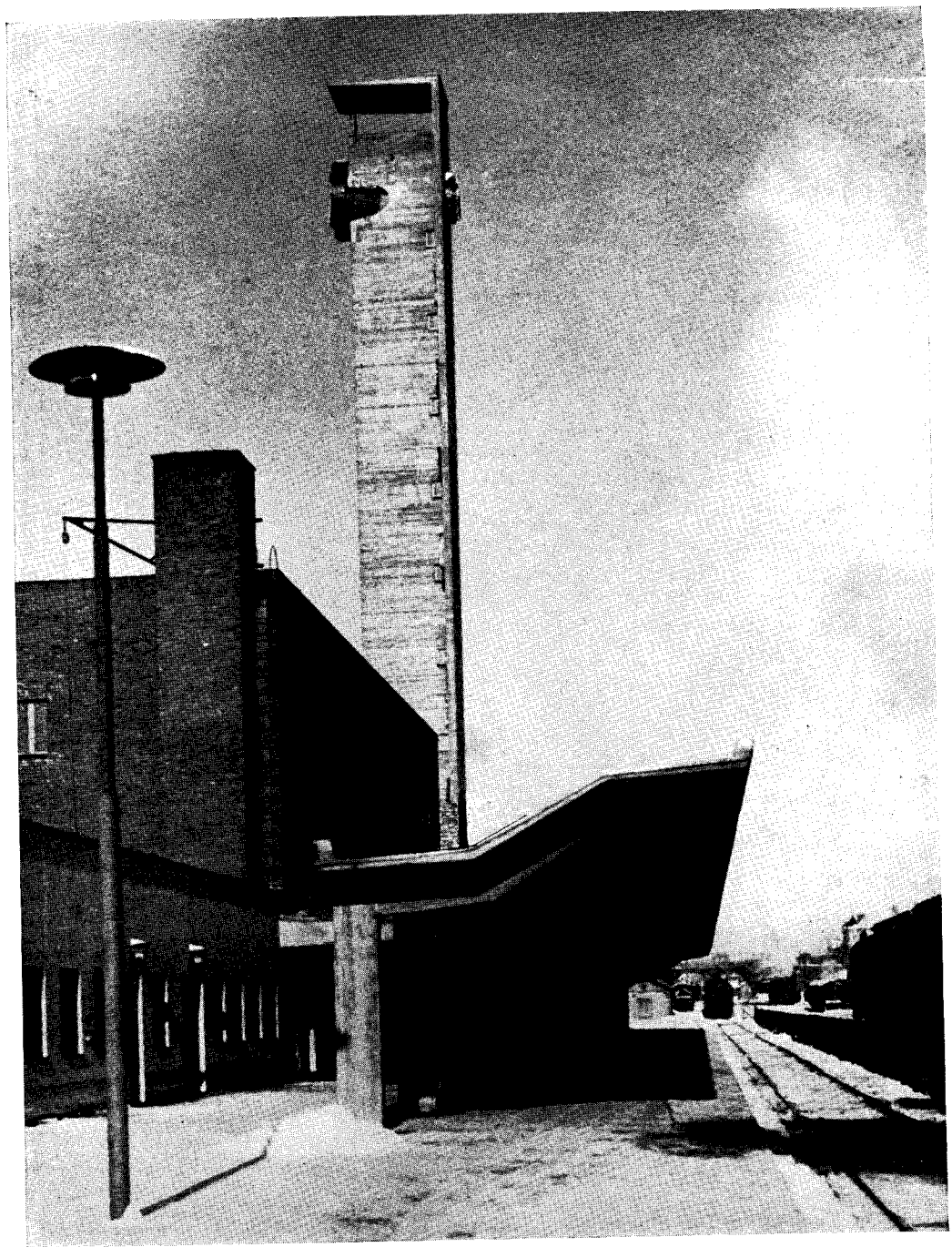

No lengthwise girders are used on the platform sheds. Joined only to the supporting columns, cantilevered girders 19 ft. 6 in. in length by 4 ft. in depth, extend in "S" form. Since only the central part of the shelter is connected to the station there is no interference with daylighting. Section (below) showing staff offices and dormitories at "N".

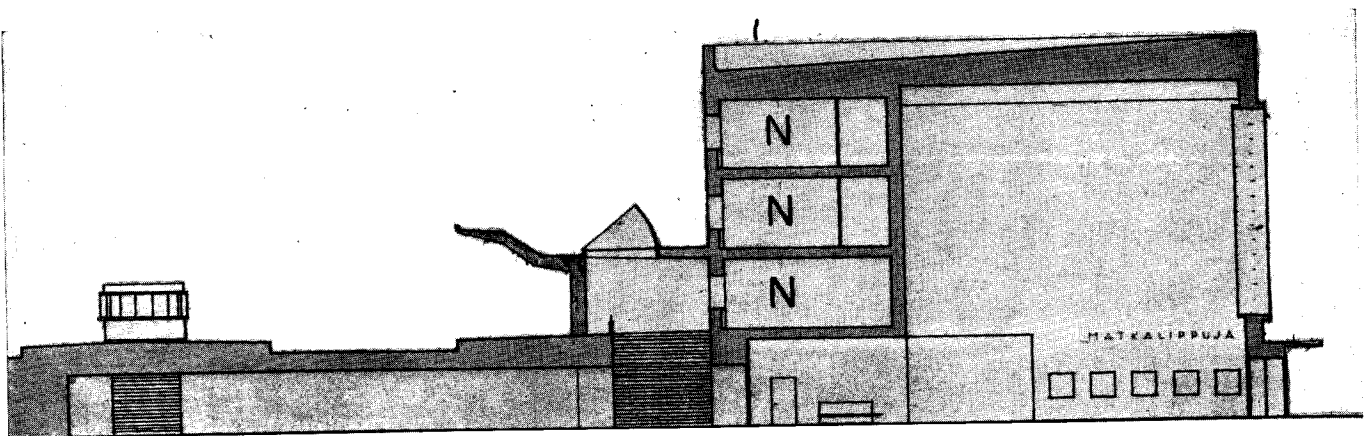

## FINNISH STATION

Photos by Roos



The structure of the waiting-room ceiling consists of saw-tooth sections of reinforced concrete 3 1/5-in. thick—except at the edges where this dimension is slightly increased—without lengthwise girders. Used over a span of 48 ft. 6 in., this construction provides greater strength by increased surface. Show windows along the front wall are an integral part of the building's design.

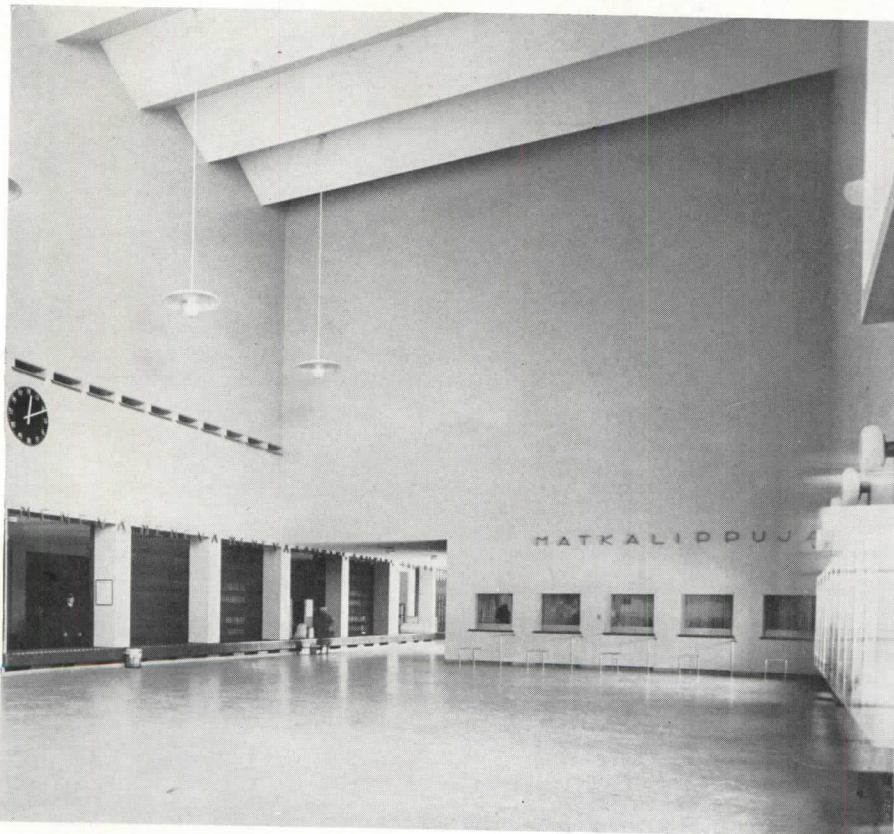

At one end of the waiting room are ticket windows; conveniently near is the luggage room. Barren of decoration except for ornamental letters above the ticket office, the waiting room is characteristic of modern Finnish work.





Douglas Andreas

## NEW TERMINAL SERVES LOCAL AND INTERURBAN BUSES

B. SPENCER NEWMAN

Architect

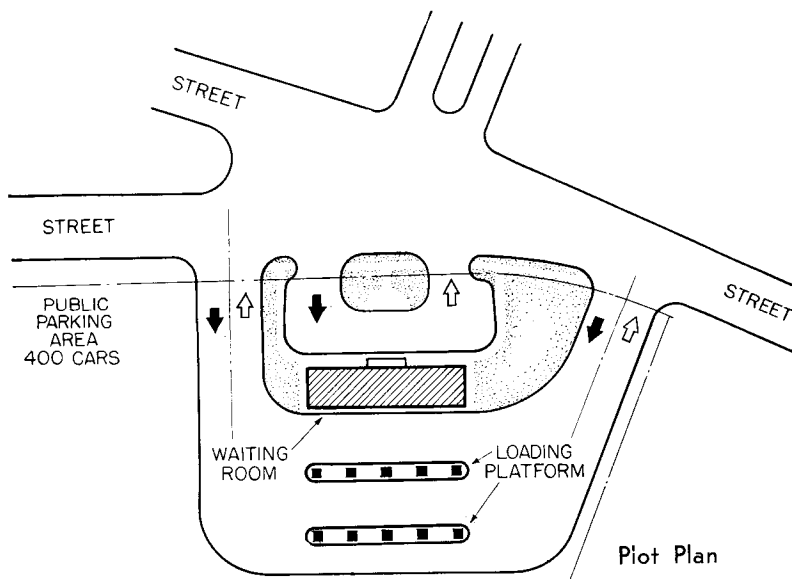

RECENTLY completed bus terminal in Hackensack, N. J., is one of two municipally owned and operated bus stations in the country. It stands on a city-owned plot of land on the banks of the Hackensack River less than three blocks from the city's shopping district. A new parkway was cut from this shopping district direct to the terminal, which is set back from the intersection and flanked by a public parking lot. Originally advocated in 1934 to alleviate chaotic traffic conditions—this city of 28,000 serves as shopping center for a surrounding population of 125,000—erection of the bus terminal became possible only when WPA aid was made available in 1936. The terminal has a steel frame, concrete floor and roof, brick walls; it was built under the direction of Wilder M. Rich, city manager, at a total cost of \$79,000, of which \$47,000 was a WPA allotment.

Photos by Douglas Andreas

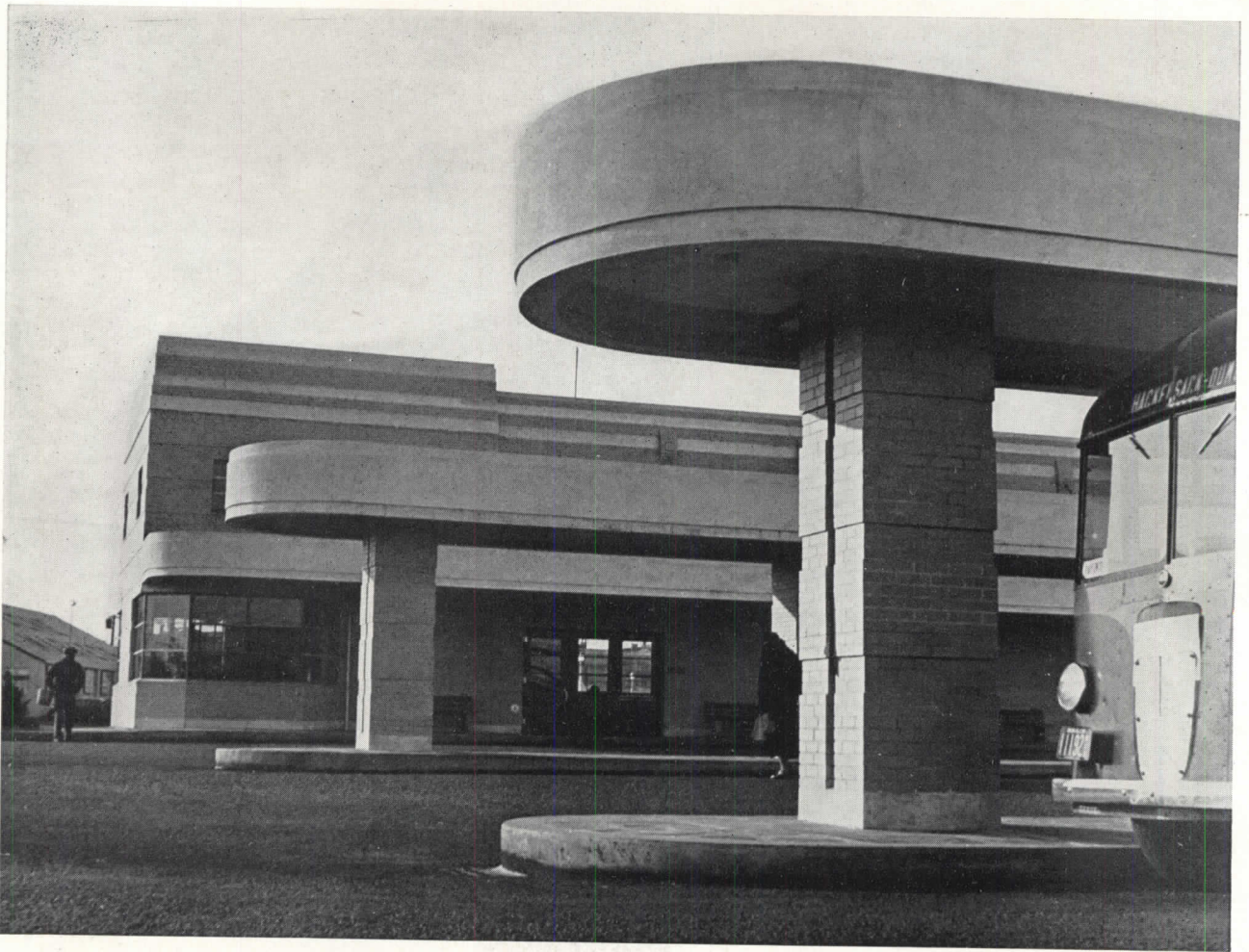

Two loading islands; each accommodates six buses

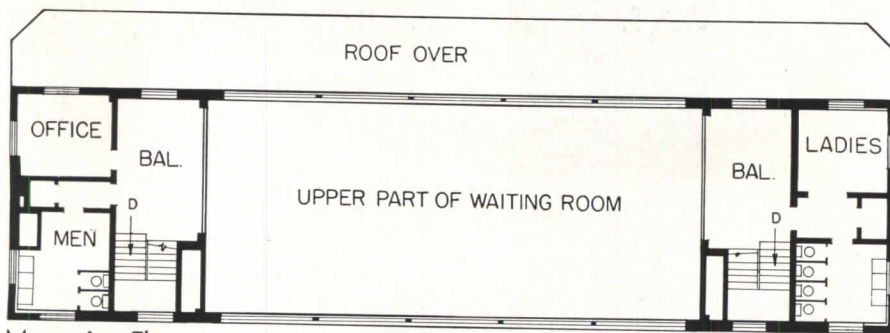

Mezzanine Floor

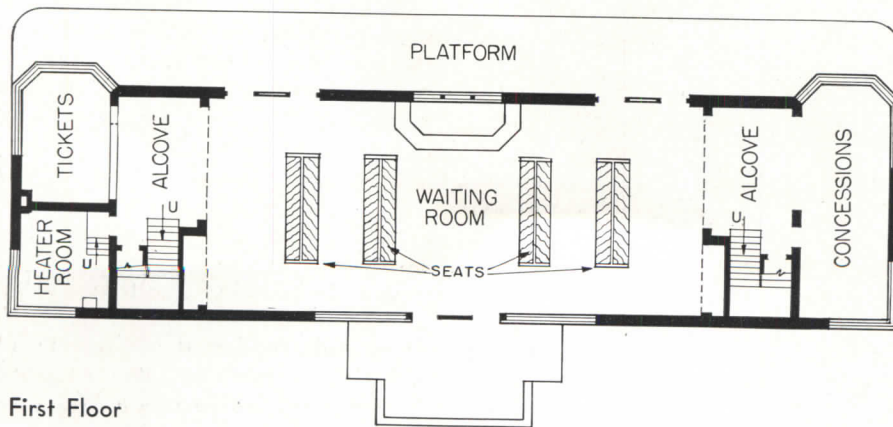

First Floor

The plan is simple. A waiting room occupies the central portion to the full height of the building. At either end are balcony floors where rest rooms, lounges and office are situated; below these on the main floor are spaces for concessions—from which comes almost half the terminal's revenue—and a ticket booth.

# JERSEY TERMINAL

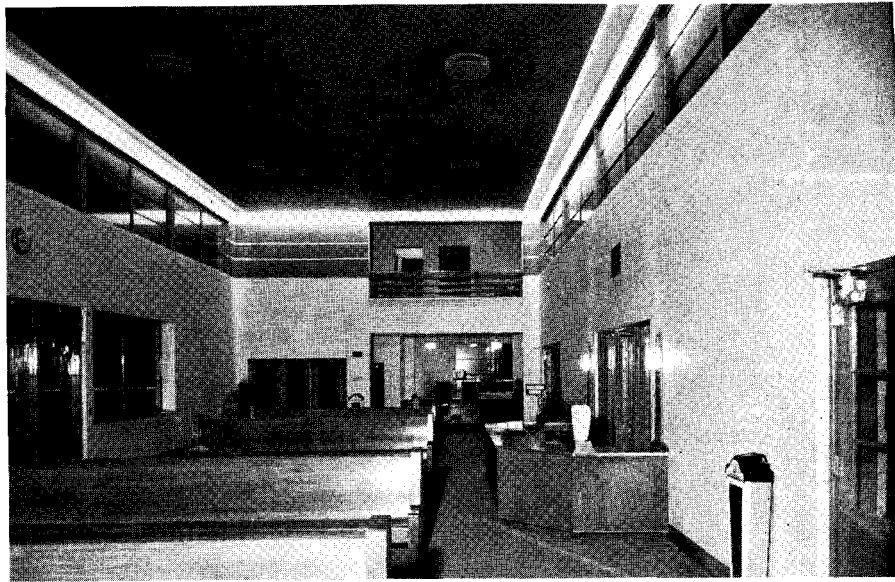

Waiting room, looking toward ticket booth, public telephones and men's lounge (top), and toward concessions and women's lounge (center). The photo mural above lockers is an air view of Hackensack and outlying districts. Indirect lighting sources are concealed at periphery of the suspended ceiling.



Rear elevation, showing exit to loading platforms. The concrete marquee is carried by cables from the wall.

# WASHINGTON, D. C.: CURB-SERVICE DICTATES A NEW FORM



Photos by W. F. Roberts Co.

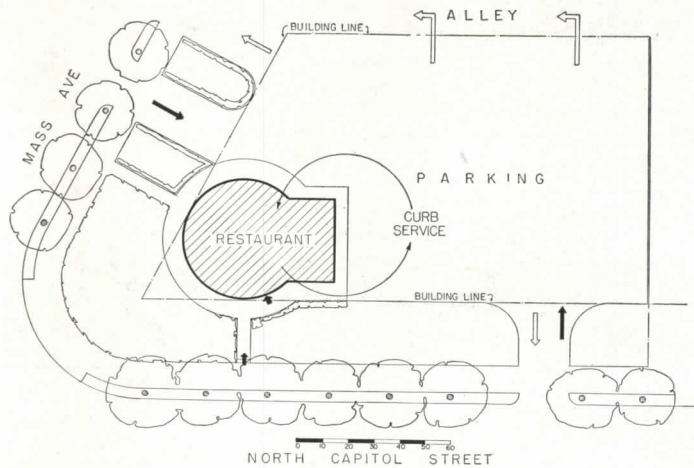

Plot Plan

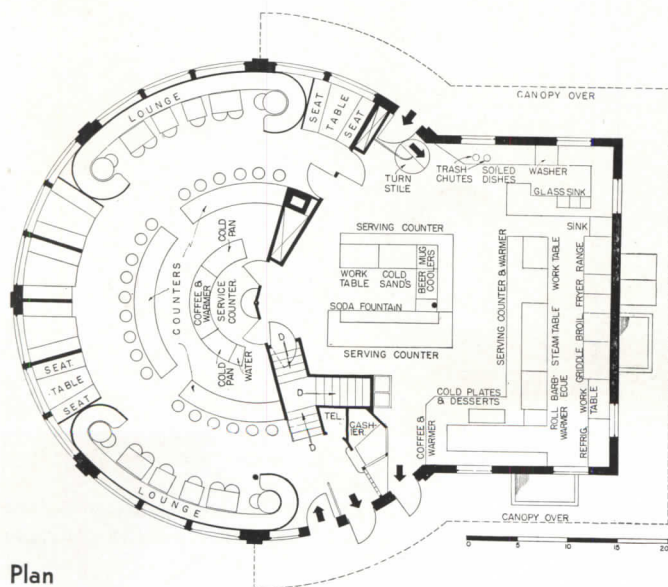

Plan

ALTHOUGH the Red Circle Food Shop, in Washington, D. C., was designed primarily for "curb service", it includes also a small interior dining room. This double purpose accounts for the size of the kitchen on the ground floor and the presence of a smaller one in the basement. The circular plan, says the architect, is the result of an attempt to "get something different from the ordinary run of drive-in restaurants and at the same time keep the cost comparable." The angular shape of the lot also influenced the design to some extent. The architect found that the circular plan provided larger seating capacity in the dining room, and a smaller and more efficient amount of space for circulation and service, than a rectangular plan. Service circulation is so arranged that one cashier takes care of checks for both exterior and interior customers. Waiters enter one side, pick up their orders at the serving counter, pass the cashier's booth and emerge at the opposite side.

While all exterior bearing walls are solid brick, and curtain walls 8-in. cinder block, the exterior surface of the circular portion consists of enameled sheets supported by a Revecon assembly. (See AR, 8/36, p. 165, for detailed description of Revecon.) All trim in this portion is aluminum Revecon while the enameled sheets are maroon and cream. The sign is stainless steel, neon-lighted, while light in the soffits floods the walls. Four-inch rockwood insulation is used in the ceiling and 1/2-in. masonite board in the walls. The entire structure has year-round air conditioning.

E. BURTON CORNING  
Architect



Dining room looking toward cashier's booth and entrance and exit doorways. The dropped ceiling in the center of the room acts as a plenum chamber for the air-conditioning system. Furnishings are of chrome steel with antique white and coral Fabricoid upholstery.

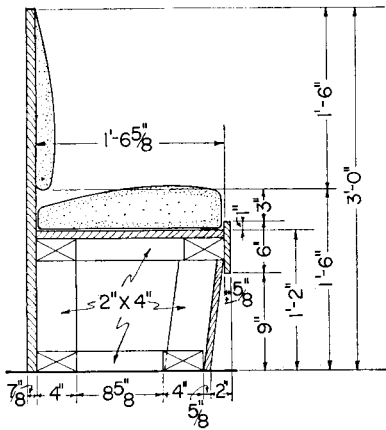

Section through lounge bench



Equipment for counter service is compactly arranged and connected by swinging doors with the kitchen. Table service is handled through the door at the upper right of the picture. Floors: black terrazzo with aluminum strips. Walls: cream-colored Marlite on 2"x3" furring; surfaces between windows covered with flesh-tinted mirrors; wainscot, peach. Ceiling: acoustical plaster. Lighting fixtures: brushed aluminum.

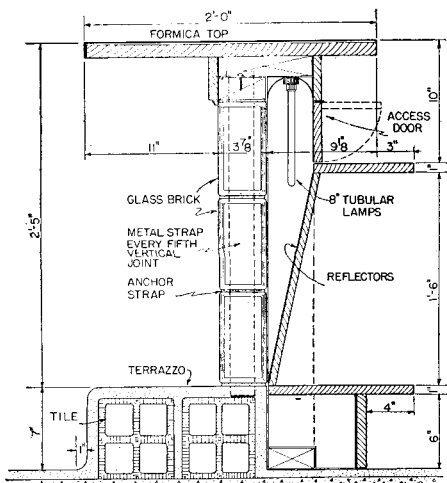

Section through counter

# CALIFORNIA: A FUNERAL HOME HAS ITS FACE LIFTED



McMillan Studio

Building after alteration



McMillan Studio

Interior of Chapel



Building before alteration

## FREDERICK H. REIMERS Architect

TRANSFORMED from two drab buildings of no architectural pretensions into a dignified establishment, the Chisholm and Dickey Funeral Home in Vallejo, California, represents a simple and effective remodeling job. Only the exterior of the building at the right was changed. The frame and stucco chapel (left, above), replacing an old frame residence, is entirely new. A new porch acts as a connecting passage to the chapel and provides extra office space for the administrative end of the business. Except for the mahogany pew top rail and blue cushions, the color scheme of the chapel is white. The new building has an air-conditioning heating plant; acoustically treated ceilings; indirect lighting throughout.

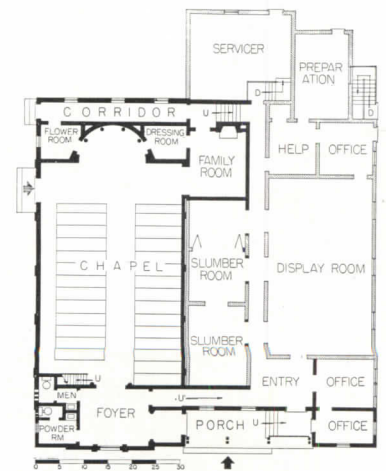

# NEW STRUCTURAL SYSTEMS

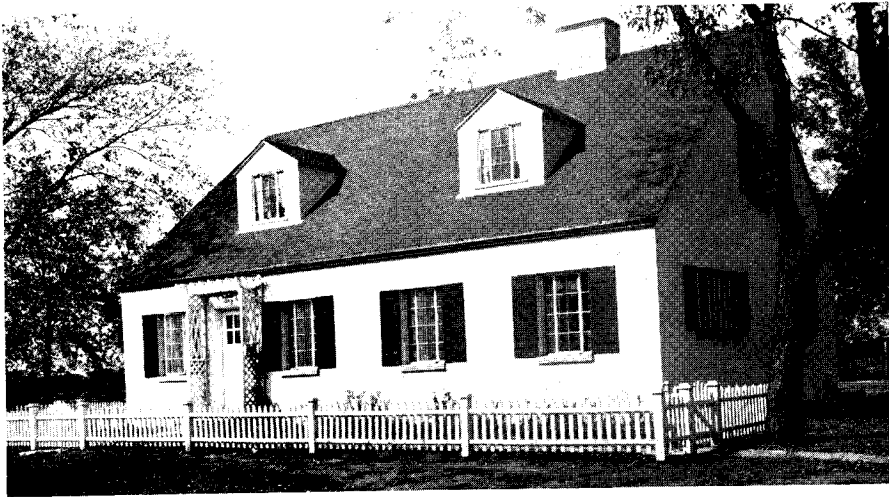

**Mold system makes possible low-cost monolithic concrete**

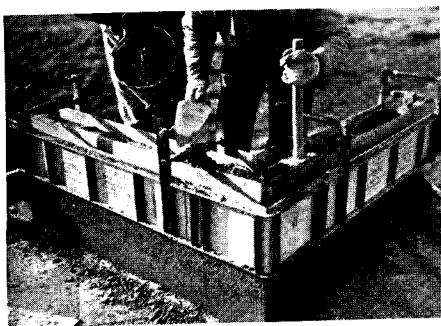

Using a fairly dry mix, a course is poured, tamped, the mold removed and a horizontal reinforcing web placed before the next course is poured.

DEMONSTRATING a new method of wall construction, this house at East Troy, Wis., was recently built by T. H. Johnson of that city. The method consists of simultaneously building two solid concrete walls, with a 2-in. dead space between, by means of molds specially designed for the purpose and manufactured by the Hollow Concrete Wall Mold Company of East Troy. Into these molds—of which there are several types, for corner assembly, 2-ft. and 4-ft. pourings—a rather dry mixture of concrete is poured. The concrete is tamped at the one-third level, and again at the top, more thoroughly so as to eliminate honeycombing. After the concrete has been roughly leveled off, the

molds are released, lifted, and moved to the next position where the operation is repeated. Between courses  $\frac{1}{4}$ -in. reinforcing rods are placed on each wall, with  $\frac{1}{4}$ -in. rods across walls every 15 inches to support the forms. There is no intervening mortar between courses, which are 9-in. high. Molds are constructed so that on one end the center core is shorter than on the other to allow for filling concrete against window and door frames, leaving the air space unbroken. Wood blocks placed in the molds at the time of filling can be used as nailers for moldings, trim, etc., or may be removed and the space used for joist pockets. Exterior wall surface can be stuccoed or painted, and interior walls can be plastered directly on the concrete without furring and lathing.

### Concrete Work

#### Materials for Walls:

140 bbl. cement at \$2.60..	\$364.00
135 cu. yd. aggregate at	
\$1.00 .....	135.00
Steel (lintels and walls)...	80.00

#### Labor:

4 men, 15 days at .75	
per hr. ....	360.00

\$939.00

#### Miscellaneous:

Concrete floor, gasoline,	
rental and depression in-	
surance .....	\$158.00

\$1,097.00

Various Trades ..... 3,455.18

**TOTAL COST ..... \$4,552.18**

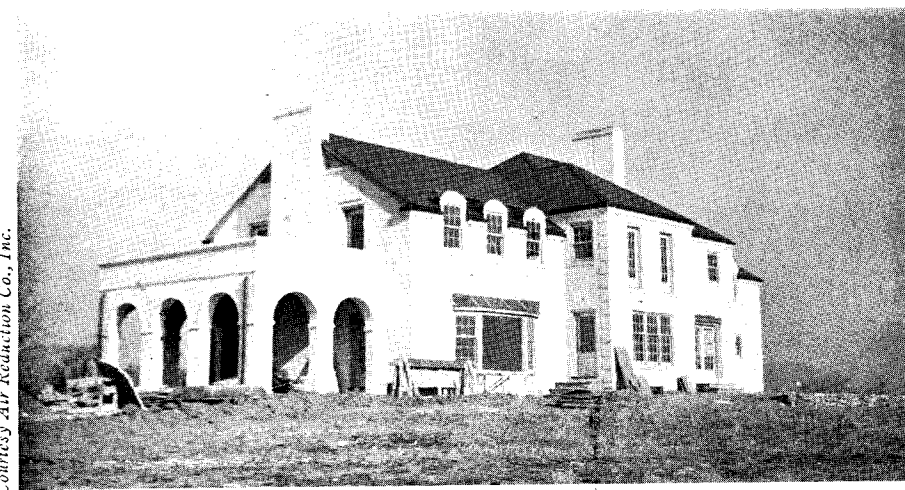

Masked by the brickwork is the welded light-steel frame

### Cost data on Pennsylvania house establishes economy of welding

INCREASED interest in welding has followed quickly the revision of building codes to permit its use, but cost figures on actual jobs have received little publicity. Just finished is a residence in

Bethlehem, Pa., of welded steel-frame construction whose cost data illustrates the potentialities of welding in the residential field. All loads are carried on the steel frame as the exterior wall is

brick veneer. Twenty-five tons of steel were used for the open-web steel frame. Secondary chords and joists rest on brick foundation piers; 4-in. wide studding is welded to the chord, and diagonal bracing to the studs. Before welding the original bracing to the studs, however, 2" x 4" wood studs are used to plumb the walls and sections. Second-floor studs are set directly over first-floor studs. A 4-in. channel, acting as girth plate, caps a row of studs, and is welded to them top and bottom. Joists and studs are so arranged that their loads come directly over load-bearing studs below the girth plate.

Hours of electric welding....	240
Estimated cost per hour of	
electric welding .....	\$3.50
Cost of welding per cu. ft....	0.0093
Cost of cutting per cu. ft....	0.00034
(Based on oxygen @ \$1.85 per	
1000 cu. ft. and acetylene	
@ \$3.65 per 1000 cu. ft.)	
Oxygen .....	990 cu. ft.
Acetylene .....	340 cu. ft.
Cost of building only.....	\$35,000.00
Cost per cu. ft. of building..	0.3889



Wide World

## Equipment used to make contact more difficult, not less



Detail, inmate's booth, visitors beyond

EXCHANGE OF anything beyond words or smiles is effectively prevented in the new visitors' gallery at the Hart's Island Penitentiary, N. Y. Thus, up-to-date equipment—the microphone, bullet-proof glass, armor-plate steel—sees another application: complete isolation of visitor from inmate. (For similar isolation of teller from depositor, see AR, 7/37, p. 31). Alongside the central inmates' gallery (above) run two narrower galleries for visitors. Separating the two is a series of steel booths, each equipped with folding stools, bullet-proof "peepholes" and two-way microphone hook-ups (left). In a row outside, minus wing walls, sit the visitors.

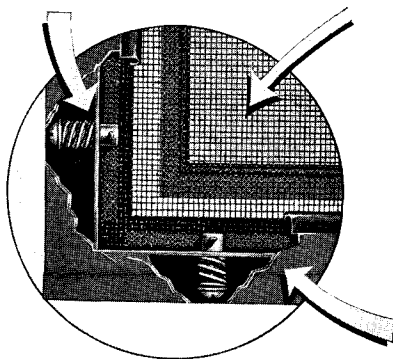

Cutaway of Trulock guard, frame with integral shock absorbers

## New detention guard eliminates unpleasant bars

LESS OFFENSIVE to the patient than the usual barred window in psychiatric institutions, are windows fitted with Trulock safety detention guards, new addition to the line of Austral Sales Co., 101 Park Ave., New York City. The unit consists of a corrosion-resistant, stainless steel alloy wire mesh in a steel-channel frame fixed in place by screws inaccessible to the patient. The wire mesh is attached to shock absorbers installed in the frame on 8-in. centers by means of shock distribution bars on all four edges. This mesh has an open

area of 43% with double crimped crossings and a minimum tensile strength of 700 lb. per linear inch. Installed experimentally at the Westchester Division of New York Hospital, safety detention screens proved "entirely satisfactory" during the year of their use, according to Dr. C. O. Cheney, medical director of that institution. Although of standard design and construction, the Trulock unit is fabricated only on order.

## "Black-light" burglar traps available in low-cost models

Low-cost photoelectric controls for intrusion protection have recently been announced by two companies. One, manufactured by Universal Control Devices, 201 N. Wells St., Chicago, is priced at \$18, and is designed for all types of offices and buildings. The other, a product of Photoswitch, Inc., 21 Chestnut St., Cambridge, Mass., retails at \$40, and is especially suitable for use in homes. It is designed for long-range use as well. Both consist of a control and a light source, which can be plugged into 110-volt AC or DC outlets.

## Non-tamperable fuse reduces fire risk

A NEW type of non-tamperable plug fuse, which cannot be bridged, has been recently developed and its use as a means of fire prevention urged by Dr. Morton G. Lloyd, chief of the Safety Codes Section of the Bureau of Standards. Since the new type of plug cannot be altered to permit overloading of wires, and plugs of different ratings are not interchangeable, fire hazards will be much reduced by its installation.

## Remote control valve aids fire fighting

A REMOTE-CONTROL hose valve manufactured by the Rockwood Sprinkler Co., 38 Harlow St., Worcester, Mass., is designed to prevent freezing in pipes and to obviate insulation of piping. There are two types of control: by operation of a break-glass station, or by a 360° revolution of the valve wheel. In either case, an impulse is transmitted which causes the valve to operate immediately. Located at various points throughout the property where there is heat during cold weather, the remote-control valves are connected with a special main valve which controls the flow of water from the city water mains or other water supply sources. Piping between these connections is normally empty of water. In a test carried out in a 23-story building, water was available on the roof in 11 seconds after the operation of one of the remote-control valves.



Courtesy "Scientific American"

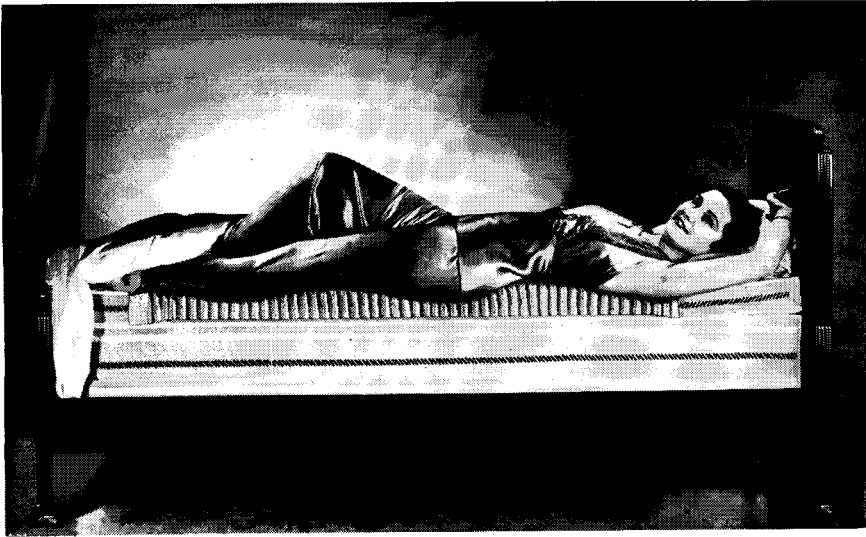

**One-piece mattress to compete with horsehair, springs and buttons**

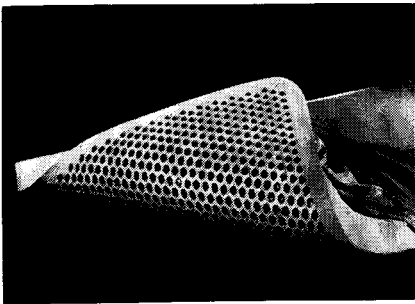

Aside from the perforations in the Sleep-Cushion (above), its sponge-rubber structure absorbs or releases air as a sponge does water. Note how the cushion conforms to body shape and position (top).

A NEW kind of mattress, made entirely of latex sponge rubber, is actually 85% air and 15% rubber. The Red-Ball Slumber-Cushion, made in standard bed sizes about 5-in. thick by the Mishawaka Rubber and Woolen Manufacturing Co., Mishawaka, Ind., eliminates padding, springs, wires, tufts and buttons. It has a perfectly smooth surface and is fabricated of latex, the milk of the rubber tree, whipped to a foam and vulcanized in a single piece. For additional resilience and ventilation the mattress is pierced in an all-over pattern with finger-sized holes. Since the air cells of the rubber release air when compressed, and fill again when pressure is lifted, the Sleep-Cushion may be said literally to "breathe."

Courtesy DuPont Style Service

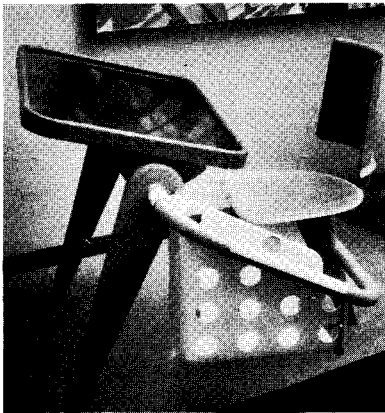
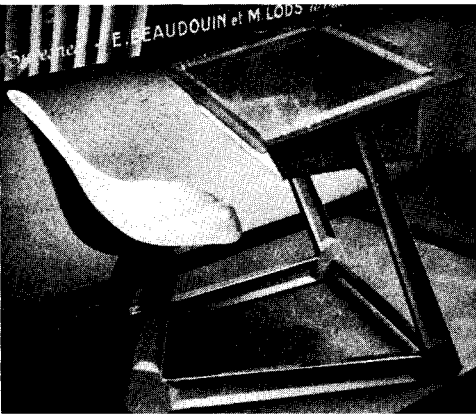

**French children to study on plastic desks**

RECENTLY exhibited in Paris were these school desks made from both opaque and transparent plastics, in combination with metal. These desks are reported high in favor because they are a less favorable medium for carrying germs, as well as for their high abrasion resistance. While still somewhat

heavy, they indicate wide potentialities of both die-casting and synthetics in the field of furniture design. (See AR, 8/36, p. 165). The designs represent a collaboration between architects and physicians to obtain scientific back and seat adjustments. Some are one-piece while others are demountable.

**Carbon dioxide lamps declared perfected**

INCANDESCENT lamps filled with carbon dioxide have been commercially perfected, according to Dr. Thomas J. Killian of the Barkon Tube Lighting Corp., 23-10 Bridge Plaza S., Long Island City, N. Y. Many previous attempts have been made to use carbon dioxide in lamps, but all were unsuccessful because of the tendency of the gas to break down under the electric charge sent through it, with consequent pressure changes. By means of a simple electronic control for the pressure, the new lamp overcomes this tendency. Because of the white spectrum of carbon dioxide, these lamps are suitable for matching colors.

**Mercury vapor lamps to make trees fluoresce**

SPECIALLY designed mercury vapor lamps will throw their rays upward to make luminous the leaves of trees on the grounds of the New York World's Fair. Because parts of the undersurfaces of green leaves fluoresce with a greenish-white light when irradiated with certain wave lengths in the high violet and ultraviolet, the leaves will appear to give off a soft light.

**Air-pressure difference used to seal doors**

NOT WITHOUT potential application to building design is an apparatus for sealing airplane doors in flight. Developed by Stephen J. Zand, acoustical engineer of Forest Hills, N. Y., the seal is rubber tubing, filled with air at ground-level pressure, surrounding the door jamb. As the plane ascends into lower air pressures, the seal swells, becoming increasingly effective and filling every crevice between door and jamb. The sealing process is reversed in descending.

**Copper sewer ring poisons tree roots**

THE COPPER carbonate ( $CuCO_3$ ), formed by the action of moisture on copper, poisons plant growth. Using this principle, the ABC Manufacturing Co., 221 South St., Quincy, Ill., has announced a simple device for preventing root obstruction in sewers. It consists of an open-end, flat ring of crimped copper to be placed in the bell between one length of sewer pipe and the next;  $CuCO_3$  does the rest.

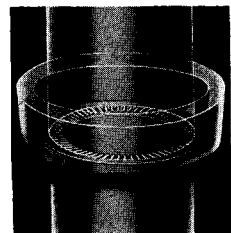

C. L. Venard



Ludlite tiles



Ludlite sheets

## Stainless steel now available in flexible surfacing material

A NEW moderate-cost surfacing material of stainless steel, with a flexible nonmetallic backing, is now in production at the Ludlum Steel Co., Watervliet, N. Y. Known as Ludlite, the new product is available in tiles 4-in. square, and in rolls 24-in. wide and 50-ft. or 100-ft. long. Ludlite is a composite of Silcrome, Ludlum's special stainless steel, and a tough, flexible, nonmetallic and waterproof backing permanently bonded together by heat and pressure. The backing material provides support for the light-gage steel sheet and makes it possible to cement Ludlite—tiles or sheets—to plaster, wood, fiberboard,

concrete, etc. A further advantage claimed for this product is that the backing has sound-deadening and insulating qualities.

Both tiles and sheeting are easily installed, for the product can be cut and shaped on the job. It can be applied either by a specially developed waterproof cement, by nails or by screws. Stainless steel molding strip in various shapes and styles for finishing edges and intersecting surfaces is available. This easy installation is said by the manufacturer to reduce materially the over-all cost as no special skill or equipment is required.

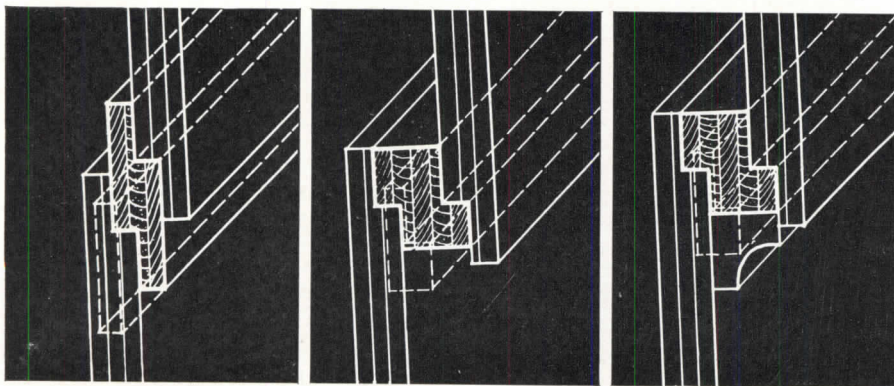

3 combinations with Harborside's accessory molds

## Weatherproof plywood siding kills insects

DEVELOPED especially for use as an exterior siding, Harborside, product of the Harbor Plywood Corp., Hoquiam, Wash., has just been made available. It is of Super-Harbord, a weatherproof plywood, hot-pressed with a cresol-formaldehyde synthetic resin binder which is insoluble in water. This binder

is toxic to insects and acts as a moisture barrier eliminating paint disintegration from under-surface moisture. Harborside units come in two sizes, 4' x 7/16" and 8' x 3/8", with either fir or redwood facings. On the 4-ft. size, the wood grain is vertical to the length; on the 8-ft. size, it is parallel. Sides and ends

are double-rabbeted, permitting a variety of joint effects. Joints may be either butted so as to produce a flush surface, or the edges may be eased to make a "V" or rounded joint. Other effects are obtained by beveling the joints and by application of accessory molds specially developed for use with Harborside. Labor costs are claimed to be lower when Harborside is used, as application is said to take less time than for either clapboard or shingles. The units are packaged in bundles containing minimum coverage for 100 sq. ft. of wall area.

## Plywood and plastic combination promises new surfacing material

A LAMINATED woven veneer recently introduced by the Parkwood Corporation, Leominster, Mass., said to be the first combination of its kind of plastics and veneer, is now in production. The product comes in four different forms, all manufactured by the same process: a hand-woven veneer, in sheet sizes up to 21" x 51", with strips running either diagonally or straight, and woven closely for a tight lock at the corners. After a clear transparent cellulose acetate is applied to one or both sides, the whole piece is subjected to great pressure in a hot-plate press. It is not released from pressure until cooled, and the result is a pliable sheet of considerable strength and hard surface. Sheets can be cut to size for installation after processing.

Type 1 consists of thin strips of wood veneer, clear-finished. Type 2 is similar to Type 1, except that colored transparent cellulose acetate is used to furnish any desired chromatic effect. The grain of the wood shows up through the surfacing. Type 3 consists of strips of wood veneer and metal—brass, copper or aluminum—treated in the same way as Type 1. The acetate surfacing keeps the metal from tarnishing or changing color. Type 4 is essentially the same as the other three, except that there are 1/2-in. interstices between the woven strips.

(The material was tested for performance during the past summer on a canoe which was put through its paces by a Maine guide, who pronounced the veneer as being lightweight, weather- and waterproof.)

This decorative material can be curved at any reasonable radius and is intended to provide an economical means of producing a parquet effect on architectural details as well as on furnishings. Its application in the automotive and aviation industries, both for construction and decoration, is being studied. So far the product has not been manufactured in large quantities.

J. A. Glenn





Patmio

### Modern museum shows Aalto work

Second in a series of 1-man architectural shows, New York City's Museum of Modern Art this month opens an exhibition of the work of the Finnish architect, Alvar Aalto. Besides photographs, drawings and models of Aalto's work, there will be a study of his famous sanitarium (above) and 40 or 50 pieces of the plywood furniture designed and fabricated by the architect.



Paul Frank & Associates

### AID moves towards stiffer requirements

The same fundamental training for interior specialists as for architects was advocated by The American Institute of Decorators at their seventh annual convention in Chicago. Heads of interior decorating departments, representing schools throughout the country, took part in the round-table discussions (above) on education.

### AIA to concentrate on housing

Housing will be the chief theme of AIA's seventieth convention to be held in New Orleans, April 19-22. Topics to be discussed at the assembly include the national housing movement, the small house problem, land utilization, relations of labor and industry to housing,

minimum standards of dwelling units, and city planning. Among reports to be presented will be that of the Institute's Housing Committee, recommending that each local housing authority include an architect as a member of its technical staff. Progress in allied fields such as

art, public works, education, registration laws, professional organization of architects and the development of the National Capitol, will also be reported. Under the direction of Moise Goldstein, convention chairman, tours of historic places in and around New Orleans, and other local events, have been arranged.

### ADS sponsors competitions bill

OPEN, ANONYMOUS competitions for all municipal work costing over \$100,000 is provided in a new bill being sponsored by the Architects and Designers Association of New York City. The bill is designed to make the "creation of civic architecture a concern of all architects, to integrate it more closely with modern social and technological trends and to give the municipality the best ideas of the majority of its architects." It is also intended to aid the architectural profession as a whole by the discovery of new talent, the prevention of monopolies of a few select architects, and the achievement of public recognition for civil service architects:

[Similar to a bill to be introduced in the Congress by the National Competitions Committee (AR, 1/38, p. 41), the ADA bill differs only in that it provides for all administrative detail—selection of a Board, drafting of programs, selection of jury, etc.]

The bill proposed two types of anonymous competitions for municipal structures costing more than \$100,000: one-stage competitions for work in the \$100,000 — \$1,000,000 price range; two-stage competitions for work ranging in cost from \$1,000,000 upward. Under the provisions of the bill these competitions would be open to all registered architects of the municipality, including those in civil service. Employment of winners would fall into two classifications: (1) full architectural employment consisting, in addition to the usual preliminary services, of providing full engineering services, working drawings, letting of contracts, supervision, etc., all to be executed at the architect's expense; (2) responsibility for and authority over the work, as in the first type, except that working drawings, engineering services, specifications, letting of contracts, supervision, etc., shall be carried out by the department having jurisdiction over the particular project, at the municipality's expense.

The ADA bill provides for a permanent Board of Competitions to prepare programs, select juries, make awards and generally protect competitors' interests. It also lays down careful rules to insure the city against impractical or expensive schemes.

## Competitions— spring brings a host

PITTSBURGH GLASS Institute announces its second competition for the use of glass in completed buildings, entries for which are due November 1, 1938. Interest in the 1937 contest was so great that the sponsors decided to extend the dates of this year's competition so as to include work built during the summer and fall. Although there is no set limit to the number of photographs of a building which may be submitted the program suggests that each entry be presented in as few prints as possible. The competition is open to all architects, designers and interior decorators, except employees of The Pittsburgh Glass Institute and its affiliates, and of The Architectural Forum, which is conducting the competition. In addition to the glass medallion designed by Sidney Wough, cash prizes totalling \$2,900 will be awarded to the winners: \$1,000 for the Grand Prize winner, \$100 for winners of first place, and \$50 for winners of mentions, in each of the 12 classifications. Information on the competition may be obtained from the Competition Adviser, Pittsburgh Glass Institute Competition, The Architectural Forum, 135 E. 42 St., New York City.

### Princeton offers several

Applications for the Lowell Palmer Fellowship in architecture for graduate study at Princeton University must be made not later than March 15. The award is open to U. S. citizens who are less than 27 years of age on October 1, 1938. In addition to exemption from fees, the winner may receive a cash award from the Palmer Fund sufficient to enable him to complete a year's residence at the University.

Two competitive prizes of \$500 each for advanced study at Princeton are also announced. They are open to men between the ages of 21 and 27 who have been employed as draftsmen in architects' offices for not less than three years, or have otherwise demonstrated their ability in architectural design. Applications for entrance to the competitions are due on April 15, and the competition will be held May 2-12. Information and application blanks may be had from Prof. M. L. Beck, McCormick Hall, Princeton, N. J.

### Art center for Wheaton

Wheaton College, Norton, Mass., has announced a competition to select an architect for its proposed art center. Closing date for entries is May 24, 1938. Details are available only from the Pro-

fessional Adviser, c/o The Architectural Forum, 135 E. 42 St., New York City.

### Five scholarships at Syracuse

Syracuse University's College of Fine Arts offers five four-year scholarships for the freshman year in architecture, open to graduates of accredited high schools. One of these carries a stipend of \$375; the other four are valued at \$187.50. Award is based on preparatory school record and drawing ability. For judging the latter, contestants must submit a portfolio of 20 examples of free-hand and mechanical drawing, and three letters of recommendation, not later than July 5, 1938. Application, accompanied by the usual matriculation fee, must be made by June 22 for entrance to the College of Fine Arts as a regular student. Further information may be obtained from Dean H. L. Butler, College of Fine Arts, Syracuse University, Syracuse, N. Y.

### Stewardson Scholarship again

The 38th annual competition for the \$1,000 John Stewardson Memorial Scholarship in Architecture is open to persons between the ages of 22 and 30 who have studied or practiced architecture in Pennsylvania for at least one year immediately preceding the scholarship award. Application forms must be sent to Edmund R. Purves, The Architects' Building, 17th and Samson Sts., Philadelphia, Pa., by March 14, 1938. Qualifying tests will be given on March 25 to those applicants who show the necessary preparation and qualifications. The Stewardson Scholarship, founded in 1897 as a memorial to the Philadelphia architect, John Stewardson, provides for a year of study either here or in foreign countries, as determined by the Committee, and under its direction.

### Landscape at Cornell

A fellowship and seven scholarships in architecture, landscape architecture and fine arts, for graduate study during 1938-39 at Cornell University have been announced. The University Fellowship in architecture or landscape architecture has a value of \$400 and, like the other graduate scholarships, exempts the holder from payment of tuition. The Fellowship and three graduate scholarships are open to students enrolled in the Cornell Graduate School who are candidates for an advanced degree. The five other scholarships, worth \$250 each, are open to graduates of four-year courses in architecture and may be held until the student has completed requirements for Cornell's B. A. degree.

Also announced are six first-year scholarships, open to students registered for their first year at Cornell, which pay one-half the year's tuition and are awarded on the basis of need for financial assistance. Forms of application are available from the Dean, College of Architecture, Cornell University, Ithaca, N. Y.

### Booth Traveling Fellowship

The College of Architecture, University of Michigan, announces that the George C. Booth Traveling Fellowship in Architecture will be offered again this year, and the competition in design will be conducted during the two weeks beginning April 8. This competition is open to all graduates of the school who have not reached their thirtieth birthday on that date. Prospective candidates should write to the office of the College of Architecture, University of Michigan, at once.

### Horn Fellowship announced

University of Pennsylvania announces that applications to compete for the Joseph V. Horn Fellowship in architecture (worth \$1,000 towards graduate studies at the University) are due April 16, and that the competition will be held May 16-28. Applications should be sent to Prof. Harry Sternfeld, School of Fine Arts, University of Pennsylvania, Philadelphia. Credentials as to character and scholastic attainment, and a statement from the local supervisor who will issue programs and receive problems, must accompany applications. Competitors must at the same time apply to Prof. George S. Koye, dean of the School of Fine Arts, for admission as students in the University.

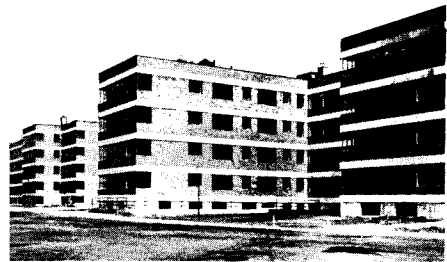

### Architect sues PWA

Charging that the PWA Housing Division used an infringement of his patented "Smooth Ceilings" system in Williamsburg Houses (above), Walter H. Wheeler, Minneapolis consulting engineer, has filed suit against the government. The suit is for \$72,211.81 which Mr. Wheeler claims is the amount saved by the use of his system.



WPA Federal Theater Photo

## Vertical section, typical slum condition

On this realistic set the Living Newspaper, WPA Federal Theater unit in New York, is now presenting its dramatization of slum conditions, "... one-third of a nation. . . ." Designed by Howard Bay, the set is 47-ft. wide, 14 ft. deep and 4 stories high; it is supported by a modern structural system of tubular steel scaffolding.

## Nathan Straus urges architects to make housing a "career"

IN HIS FIRST public appearance since he assumed office three months ago, Nathan Straus, Administrator of the U. S. Housing Authority, last month gave his first broad outline of USHA's policies when he spoke before representatives of nearly a score of architectural and engineering organizations of metropolitan New York. In a significant passage, he addressed "a personal message to the architects of America."

"One of the greatest services you can render to the American architectural profession and to the cause of low-cost housing," said Mr. Straus, "is to encourage a different attitude toward government housing among members of your profession. A government housing project should not be regarded merely as an architectural job. There should be a pride in being given an opportunity to engage in this type of work. Government housing should not be regarded merely as a source of fees. It should be, and I hope it will be for many of our architects, a career.

"Today we are faced with the definite need for adequately trained technical staffs on local housing authorities. Trained 'housing' architects, ready to devote themselves in the government service to the cause of low-cost housing, are badly needed today. . . .

"This field for architects already has been recognized and assumed in countries abroad," Mr. Straus pointed out. "The outstanding housing architects

abroad have been associated with slum-clearance housing legislation and policy continuously from its inception. It was (often) they who organized the co-operatives, assisted in the organization of the tenant associations and educated the trade unions to take leadership in the housing movement. There is need for work along similar lines by the architects of the United States, for there is opening up in this country today like opportunities for making slum-clearance and low-rent housing construction a life career. May our own architects make equal use of these opportunities."

## Urges modification of Act

Speaking on the authority itself, Mr. Straus indicated several basic changes in policy from that of PWA's Housing Division. Most important was that USHA, unlike its predecessor, would use only "low-cost land which is readily available in large plots. This will," said he, "exclude use of land in the slums of our cities which is usually held at high prices." He also indicated that Senator Wagner, sponsor of the original Act, would introduce an amendment to allow the Authority to loan up to 100% of the project's capital cost. The present limit of 90% has made it impossible for many cities to participate: as an alternate the bill proposes to increase the city's contribution towards annual rental subsidy from the present 1:5 ratio to 3:5.

## Hygienic standards set for housing

MARKING ITS first official entry into the housing field, The American Public Health Association recently established a Committee on Hygiene of Housing. First work of that Committee was released last month in a report on "Basic Principles of Healthful Housing." The report—a preliminary one designed primarily for distribution among the many local housing agencies being created to take advantage of the U. S. Housing Act—represents an effort to present in nontechnical language the minimum hygienic requirements which must be met to make housing "healthful."

Although most of the material included is already available in housing circles, the report is valuable for expressing minimal standards in terms of hygienic (rather than purely technical) requirements. Working backwards from basic human needs—physiological and psychological protection, protection against contagion and accident—the report coordinates the best accepted standards of planning, construction and equipment. "Basic Principles of Healthful Housing" is being distributed jointly by the Committee, New Haven, Conn., and National Association of Housing Officials, Chicago, Ill.

## Propose new bill to liberalize housing act

A 3-POINT liberalization of the U. S. Housing Act (Wagner-Steagall Bill) is proposed in a new bill drafted by FAECT and soon to be introduced into Congress. While supporting the present USHA under Nathan Straus, FAECT feels that the maximum of 100,000 dwelling units possible under the Act is "painfully inadequate." Under the terms of the new bill, the present Act would be amended to provide for: 10,000,000 new dwelling units in the next ten years, a national maximum rent of \$6 p.r.p.m., and payment of prevailing wages to all labor, including architects and designers.

## Housing congress to meet in Mexico City

ASSEMBLING for the first time in the Western Hemisphere, the International Housing and Town Planning Congress meets this year in Mexico City from August 13th to 20th. After the Congress proper, which is being held under the patronage of President Cardenas, a six-day study tour of some of Mexico's most important developments is proposed. The Congress subjects will be three: underground planning, tropical housing and planning of recreation and leisure time.

# IN ALLIED FIELDS

## "Eskimo letter" to be painted out of mural

UNTIL ROCKWELL KENT cashed the check he received as final payment for this \$3,000 mural in the Federal Post Office Building, Washington, D. C., the painting was technically his property. When the check was cashed recently, Treasury procurement officials lost no time in preparing to eradicate a message from Alaska which appears in the center of the painting. The message, written in an obscure Eskimo dialect, is translated thus: "To the people of Puerto Rico, our friends! Go ahead. Let us change chiefs. That alone can make us free." Vilhjalmur Stefansson, noted Arctic explorer, interprets this as an exhortation to the Puerto Ricans to throw off American rule. A storm of protest against the use of propaganda in a Federal building followed this explanation, but nothing could be done until the question of ownership was solved. Inevitably recalling the dispute over Diego Rivera's Rockefeller Center murals, this case differs in its conclusion; for only the offending message will be obliterated.



Wide World

The modern miracle of the air mail makes it possible for the Puerto Rican postman (center above) to deliver an open letter whose message, microscopic though it is, has become the center of a nation-wide controversy. Treasury officials announce the letter will be replaced.

## New Florida studio gives artists "asylum" from world

IN THE HEART of Florida's lake country, the recently organized Research Studio at Maitland is seeking to encourage American artists toward an "adventurous and experimental approach" to the art problems of today. Founded by Mary Bok, the Studio's purpose is to do for artists what George Foster Peabody's "Yaddo"—a subsidized "retreat" at Saratoga Springs, N. Y.—does for writers. The means to this end is a retreat whose arrangement of buildings as well as its secluded location is intended "to insure a creative atmosphere of work and contemplation." In order that no financial strain shall mar this atmosphere, artists who are invited to live at the studio during its annual January-to-May season are at no expense other than transportation, materials and personal expenditures.

André Smith, director of the Studio, designed the buildings and supervised their construction. The "retreat" consists of a walled rectangle whose connected buildings face inward around a number of courts. "Taking advantage of the cement block construction," says Mr. Smith, "I have stressed structural forms in the gates and doorways, and ornamented them with a concentration of rich carving in cement. This has resulted in a sort of Aztec-Mayan suggestion. The ornamentation for the most part was done on the blocks before they were built into the walls."



Pool in the Studio Court; exhibition gallery (right) for separate display

Except for these carvings, wall surfaces are plain and unbroken. For extra ventilation and for decoration of garden seats, Mr. Smith uses grilles built up of cement over a sheet of paper on which the design is drawn.

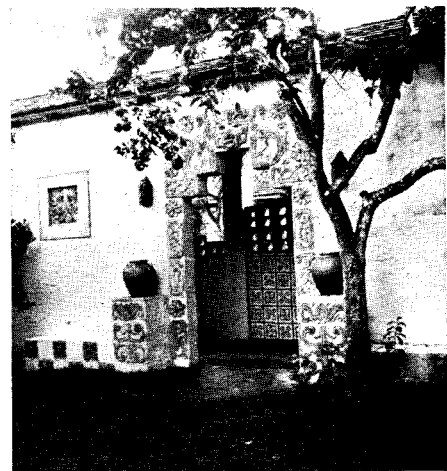

Detail, main entrance

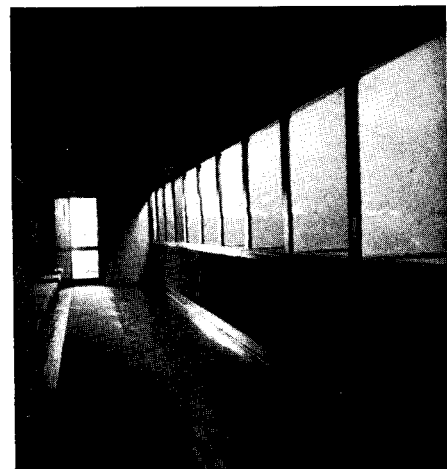

# NEW INFORMATION FOR THE BUILDING FIELD

## Books

### General

*Air Conditioning in Summer and Winter.* By Richard E. Holmes. McGraw-Hill Book Co., Inc., 330 W. 42 St., New York, N. Y. Price, \$3.

*Contemporary Art Applied to the Store and its Display.* By Frederick J. Kiesler. Brentano's, publishers, New York, N. Y. Price, \$2.50.

*Great Georgian Houses of America, Vol. II, 1937 Edition.* Architect's Emergency Committee.

*Sheet Metal Work.* By William Neubecker. American Technical Society, Drexel Ave. & 58 St., Chicago, Ill. Price, \$2.50.

### Manufacturers' publications

#### Structural Materials and Parts

*Architectural Design of Concrete Bridges.* Portland Cement Association, 33 W. Grand Ave., Chicago, Ill.

*Bilco All-Metal Copper Steel Cellar Bulkheads.* Bilco Manufacturing Co., New Haven, Conn.

*Controlled Air Circulation for Industrial and Commercial Buildings with the Swartwout Rotary Ball Bearing Ventilator.* The Swartwout Co., Cleveland, Ohio.

*Don't Be Hoodwinked on your Air Conditioning Problem.* For the consumer. National Radiator Corp., Johnstown, Pa.

*Duronz Manual of High Strength Silicon Bronzes.* Bridgeport Brass Co., Bridgeport, Conn.

*Handbook of Douglas Fir Plywood.* Douglas Fir Plywood Association, Tacoma, Wash.

*Heating and Ventilating.* Alberger Heaters. Alberger Heater Co., 281-289 Chicago St., Buffalo, N. Y.

*Higgin Venetian Blinds, Metal Frame Storm Sash and All-Metal Weatherstrips.* Higgin Products, Inc., Newport, Ky.

*Kewanee Boilers.* Kewanee Boiler Corp., Kewanee, Ill.

*Monowall Panels for Modern Interiors.* Standard Wall Covering Co., Inc., 1819-1831, N. 9 St., Philadelphia, Pa.

*Pressure Treated Timber—From the Tree to the Job.* Wood Preserving Corp., Koppers Bldg., Pittsburgh, Pa.

*Swing into Radiant Comfort.* For the consumer. American Radiator Co., 40 W. 40 St., New York, N. Y.

*Shock-Proof Malleable Railing Posts.* The Lake City Malleable Co., 5000 Lakeside Ave., Cleveland, Ohio.

*The Pleasantaire Hand Book.* Pleasantaire Corp., 304 E. 45 St., New York, N. Y.

### Electrical Equipment

*Arrow Wiring Device Catalog No. 26, and H. & H. Wiring Device Catalog "W."* Arrow Hart & Hegeman Electric Co., 103 Hawthorne St., Hartford, Conn.

*Electric Control Devices.* Automatic Switch Co., 154 Grand St., New York, N. Y.

*Mercury Light for Better Sight.* General Electric Vapor Lamp Co., Hoboken, N. J.

### Equipment

*Ashton Industrial Gages.* The Ashton Valve Co., Cambridge, Mass.

*Simmons Sleeping Equipment and Metal Furniture for Hospitals and Institutions, Catalog No. 18.* Simmons Co., Contract Division, 222 N. Bank Drive, Chicago, Ill.

*Solid Bronze Hardware.* Mesker Bros. Iron Co., St. Louis, Mo.

### Material Proofing

*Modern Principles in Paint and Decoration.* United Gypsum Co., 300 W. Adams St., Chicago, Ill.

## CHANGE OF ADDRESS

The RECORD publishes changes of address only on request, making no attempt to keep a day-to-day account. Only organization in the country with facilities for this is Sweet's Catalog Service, whose painstakingly maintained list undergoes an average of 23 changes per day for every working day in the year.

Gaarwood M. Grimes, architect, announces that he has moved to Room 905, Republic Building, Louisville, Ky.

Gilbert D. Fish and Elwyn E. Seelye have formed a partnership as consulting engineers in the welding field, at 101 Park Ave., New York, N. Y.

Arthur G. Cromwell is now located in his new studios at 264 Plymouth Ave. S., Rochester, N. Y.

Louis A. Brown, Jr., architect, announces that his headquarters are now at 603 National Bank Building, Charlottesville, Va., and that he will divide his time between that office and New York.

Walter J. Konrady, formerly of Voorhees, Gmelin & Walker, has recently been appointed architect for Presbrey-Leland Studios, 681 Fifth Ave., New York, N. Y.

Behee & Kraemer, AIA architects, announce the removal of their offices to 27 Washington St., Newark, N. J.

Robert C. Weinberg announces his removal to 21 Washington Sq. N., New York, N. Y.

Myron Bement Smith has returned from Iran, and is now located at the Yale Club, Vanderbilt Ave., New York, N. Y.

Robert P. Greenleaf, M. E., announces the establishment of an office for engineering consultation and design with special reference to air conditioning at 2804 East 132 St., Cleveland, Ohio.

Walter F. Martens, architect, has moved to 507 Great Kanawha Building, Charleston, W. Va.

Alonzo J. Harriman formerly of the firm of Harry S. Coombs—Alonzo J. Harriman, architects, Lewiston, Me., announces the opening of an office for the practice of architecture at 270 Turner St., Auburn, Me.

Herman B. Gelfand, architect, announces the removal of his architectural offices to 875 Broad St., Newark, N. J.

## CALENDAR OF EVENTS

• **March 10**—Closing date, return of entry slips, Architectural League Exhibition.

• **March 15**—Closing date, entries to competition for design of table and floor lamps, Illuminating Engineering Society, 51 Madison Ave., New York, N. Y.

• **March 15**—Closing date, Higgins Ink Mechanical Drawing Competition, Scholastic Awards, Chamber of Commerce Building, Pittsburgh, Pa.

• **March 15**—Closing date, applications for Lowell M. Palmer Fellowship in Architecture, Princeton University, Princeton, N. J.

• **March 17**—Mass meeting of New York City registered architects under auspices of Architects and Designers Association, New School for Social Research, 66 W. 12th St., New York City.

• **March 31**—Closing date, competition for Structural and Architectural Design of Elevated Highway, American Institute of Steel Construction, 200 Madison Ave., New York, N. Y.

• **April 1**—Closing date, competition for design of sculptured group for World's Fair, Metropolitan Life Insurance Co., 1 Madison Ave., New York, N. Y.

• **April 19-22**—Annual Convention, American Institute of Architects, New Orleans, La.



# DESIGN TRENDS



“Moderne Bauformen”

ARCHITECTURAL  
RECORD



*Imandt*

**THE MODERN NURSERY**

**Cannot be planned like an elementary school . . . . .**  
**Is different from a kindergarten . . . . .**  
**Presents a new problem to be solved in every community plan**

# The Modern Nursery School

By DOUGLAS HASKELL

THAT NURSERY schools are beginning to spread rapidly should occasion no surprise. More astonishing is the fact that the movement did not develop faster. We all know what has been lost to small children as their parents have gradually moved from spacious farms to closely packed city apartments, and as the mother's work has moved out of the house into office and factory; what is new is the idea that something can—and must—be done about it on a broad social scale. Nursery schools have hitherto been the prerogatives of the well-to-do, whereas it is becoming manifest that they are an utter necessity for those whose income is kept low. The opportunity has been individual, but the need is proving social.

Our first "emergency" programs, under the WPA, have in fact served public health, which is socially indispensable, equally with education. The aim has been to remove the smallest and most helpless of the State's citizens for at least part of the day from the worst effects of living in rotten dwellings. In March of 1937, the project reported 52,000 children enrolled in 1,797 schools; the total number cared for since 1933 has been over 150,000. Similar indications come from all over the world. Most extreme has been the instance of Vienna, which has used its large kindergarten program of scientific child feeding and care as an instrument necessary for the very survival of its working population.

Nurseries opened during an emergency are confined to improvised quarters; but as the emphasis turns from catch measures toward new and better permanent housing, no community or housing project can safely be planned without a nursery. This is true no matter whether the project is public or private, and regardless of its social stratification. New nurseries are reported not only in American government-built towns such as Arthurdale, West Virginia, but in elegant apartments such as the latest one in St. Pancras, London, and in solid cooperative enterprises, such as the latest built in Stockholm, Sweden.

Fortunately, a similar expansion of nursery training schools is occurring. These are becoming a regular feature in colleges and universities, sometimes under departments of home economics, sometimes under psychology departments. New York City is now planning such a nursery as an innovation in a public high school.

As nurseries and playgrounds become customary elements in new community and housing schemes, a debate develops as to whether they should be provided by the building operator and charged to rent, or whether they should be provided by the local government and sustained by taxes. Whatever the answer, the debate in itself calls attention to the central necessity for nursery schools of one kind or the other.

What brings the need? Urban apartment life, or, in other words, industrial society. Neither rich nor poor can do justice at home to the small child in the present

city setup. Gone is the accessible back yard; family units are smaller, so that there are neither the many brothers and sisters to play with nor the grandmother or aunt to provide care throughout the day. If the well-to-do woman, as result, has become dependent on her children's "nanny", the working woman on the other hand has been compelled even more strictly to leave her children throughout the day not in desirable hands but merely in available ones. Under such conditions the trained nursery teacher, though making no attempt to replace family affection, is in a position to give the child far better care than the family can give throughout the working day. On the other hand, day nurseries with untrained attendants do not achieve their aim of postponing education; they only make it bad.

From the architect's standpoint, the modern nursery is different from a kindergarten; it cannot be planned as a grade school; it represents a new problem to be freshly solved. Merely reducing the dimensions of grade school or kindergarten equipment produces a caricature similar to the primitive painters' representations of children as dwarfed old men.

Small children cannot go far without supervision; they need frequent washing and toileting, always supervised. Many a handsome nursery building eats its head off in supervision costs because of misplaced hallways, stairs, cloakrooms, toilets. It is not enough simply to lower the fixtures!

With regard to room space, the fact is already familiar that small children cannot be kept sitting still, that their education is all activity, and therefore requires a large allotment of space. Ignored is the converse: all the activity of the nursery child is education. Processes which at a later age are merely incidental loom before the small child as the central problems of his young life. Therefore, such actions as changing clothes, washing or toileting, are not mere preliminaries to the day's educational program, but *are* the education in themselves. It follows that the architect who tucks away toilets and cloakrooms into the waste areas of the building for the sake of "neatness" is misplacing an important part of the school's direct educational equipment.

The special nature of the small child is of utmost importance in the planning of individual nursery rooms in relation to the school as a whole. Within the room the architect, in effect, establishes the child's environment for the day. The world of so small a child must not be too large, must not be too complex, must be compact and in large part familiar. If overwhelmed with too many new impressions, the child masters none. This consideration has led nursery heads to advocate that the child's day be confined to the single large room with a few dependent areas and very few necessary excursions. The present design study is perhaps the first that follows this idea straight through.

## ORGANIZATION OF THE BUILDING

**Once inside the building, the small child must remain always within easy reach of one teacher's and one assistant's eyes and ears!**

ANY REQUIREMENT that takes the child away from the immediate vicinity of his teacher requires extra staff wasted on mere supervision routine. Such overhead far exceeds the initial expense required to organize the building properly around self-contained nursery rooms.

### TYPICAL VIOLATIONS

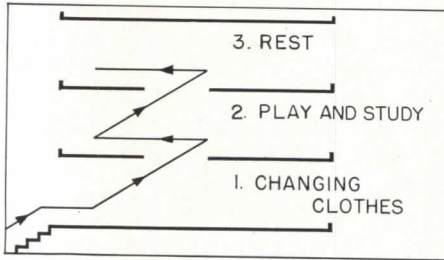

#### 1. STAIRS

This kind of organization—used in the nursery building of a leading Eastern college—looks well on paper but is wholly misconceived. By interposing stairs between each successive phase of the child's routine, it introduces extra hazards, extra staff, extra costs, and a horribly tired back whenever a teacher has to carry a baby. All who work there blame the architect.

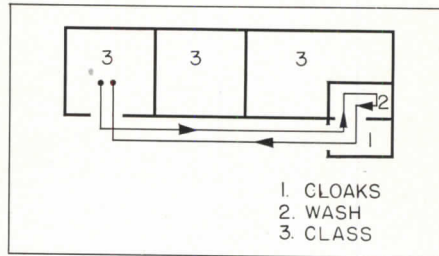

#### 2. LONG HALLS

The most common error of all is long halls. Every trip to a distant cloak-room or toilet calls for an accompanying adult. Good planning keeps these facilities close to the room without undue initial cost, and the final cost is less. Halls should be for rare use.

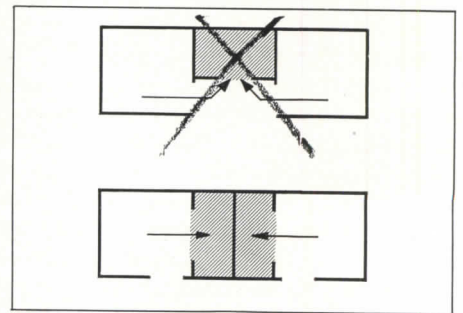

#### 3. PARTITIONS

Shifting a partition gives direct, separate, visible access from each room, without altering equipment.

### Small children in groups are extremely hard to move!

Therefore each group must be kept, through the entire day, within its own limited and compact area, fully equipped with everything the group requires.

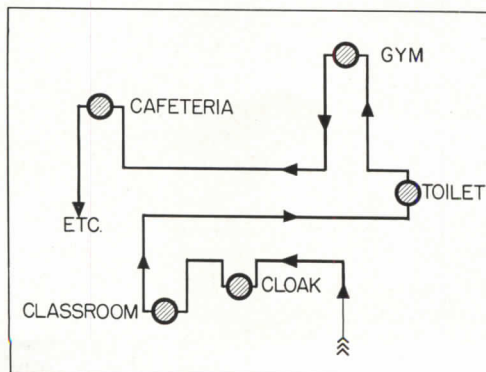

Grade school activities are separated, like this.



But the nursery school nucleus is self-contained.

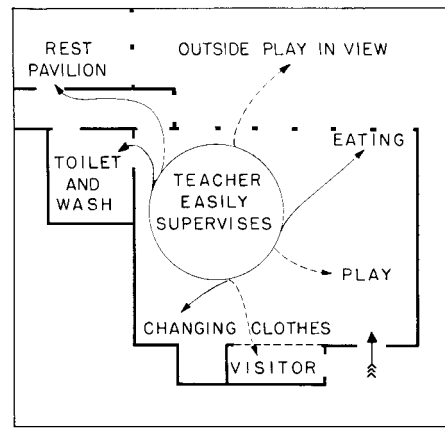

### Summary on School Organization

A good nursery school will be organized around a series of rooms, each all-sufficient for the child's full day, with every facility either self-contained or in subsidiary areas opening directly out of the room. Such direct connection is valuable even in the playground.

From the child's standpoint, what is desired is a complete, compact environment, free of outside disturbances, and small enough so that the small child, to whom an ordinary room is already enormous, is not lost in it.

From the teacher's standpoint, the central problem is minimal motion, the least possible carrying of children or things, and easy supervision: therefore no need for frequent use of long stairs and halls.

Apart from the nursery rooms there are the following administrative requirements: 1. Reception space; 2. Office space; 3. Health examination room; 4. Isolation room for children needing quiet; this is by no means to be considered punitive; 5. Storage for extra cots, reserve supplies of clay and other craft materials, and teachers' belongings; 6. Cloak space, toilet, and if possible a small quiet room for the staff; 7. For food preparation, kitchen, though rarely a dining room; 8. Sanitation: broom closets, slop sinks on every floor.

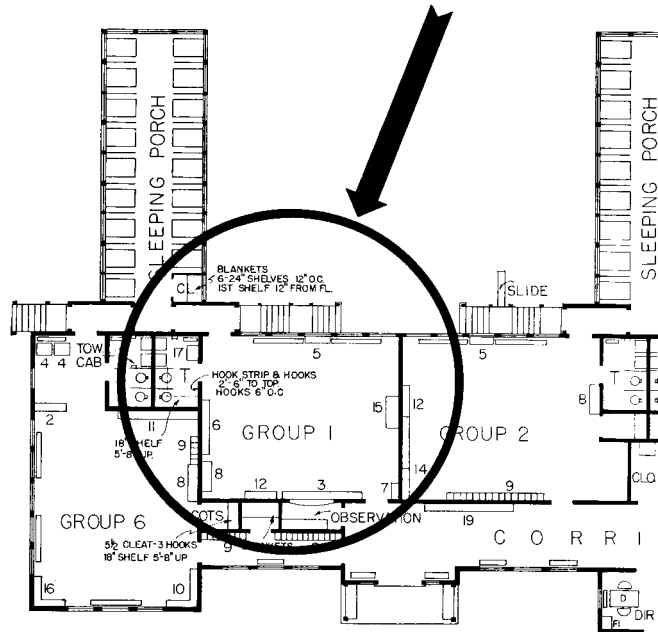

Showing how a good nursery school plan such as that at Arthurdale, West Virginia, is composed of a series of self-contained nursery units. Fellheimer & Wagner, Architects.



Three degrees of openness in close conjunction. School Home for Small Children, Balbuena, Mexico City. Jose Villagran Garcia and Enrique de la Mora, Architects.

Esther Born



Esther Born

Semi-open protected playroom connected by partly shaded ramp to open playground. School Home for Small Children, Balbuena, Mexico City. Jose Villagran Garcia and Enrique de la Mora, Architects.

## Organization of the Nursery Room

SINCE THE room and its adjacent areas furnish the child's complete environment throughout the day, the facilities must provide for changing clothes, washing, toileting, play and study, eating, rest, and a direct exit to outdoor play.

*Room Size* depends on the age and number of children served, and the activities allowed them. Activities vary so widely from school to school as to render computations of area in terms of square feet per child almost meaningless. Miss Grace Langdon of Teachers College, Columbia University, gives 60-70 sq. ft per child as a standard for a mixed group of 20 children. The New York State Education Department requires, as a *minimum*, that every child under five receive at least 35 sq. ft. of indoor space and 200 sq. ft. outdoors; for children from five to seven the standards are, respectively, 25 sq. ft. and again 200 sq. ft. Acceptable plans developed on a basis of 50-55 sq. ft. per child have, because of unusual efficiency, served larger numbers, which brought the average down to 40 sq. ft. Such figures serve chiefly to indicate how much more generous the spaces must be in nursery schools than in elementary schools.

The top number of children that one teacher can adequately handle alone is placed by the Harriet Johnson Nursery School at eight to ten (depending on age); with an assistant, an average of 16. New York State requires one teacher to every six children below the age of three; to every 10 at the age of three; to every 15 at four; above that age public school standards prevail.

No serviceable room size can be arrived at without first determining the areas required for each different function, not neglecting the all-important requirement of *empty, open floor*.

*General Room Requirements* are worked out chiefly in relation to the all-important *floor*, which is the chief habitus of the children. Heating must warm the floor; any successful panel scheme of heating will find nurseries its enthusiastic users. Ventilation must prevent drafts on the floor. Air conditioning may be out of reach because of expense, but windows, at least, can be well designed. Except in mild climates, casement sash is not advisable; double-hung sash is simplest to operate and cheapest; it must be provided with shields. Fixed windows with intermittent, high-placed sash that pivot or hinge inward are gaining favor because of combined ventilating and storm-shedding qualities.

Window area to floor area is usually computed as 1:4, although deeper rooms would be permissible because work in the rear is not nearly so eye-straining as public school reading would be. Indeed, many nursery heads favor deeper rooms for convenient layout of play areas.

Floor material must be smooth (not slick), safe (no splinters), warm, tough, resilient, easily cleaned. Heavy linoleum, rubber or cork, is preferred. Wall material must be smooth and easily cleaned. Any architect who insists on precious wooden paneling is acting the part of a baby and asking the children to act as adults by leaving his toy alone. Sound deadening is required in both walls and ceiling, especially where the nursery is part of a housing scheme.

Blackboards are not needed; five or six running feet of bulletin space are ample; but tacking strips should be run around the entire room, one at 48" above the floor for the children, and two others at 24" and 36" above the lower pieces of wall furniture and not over 6'-0" above the floor.

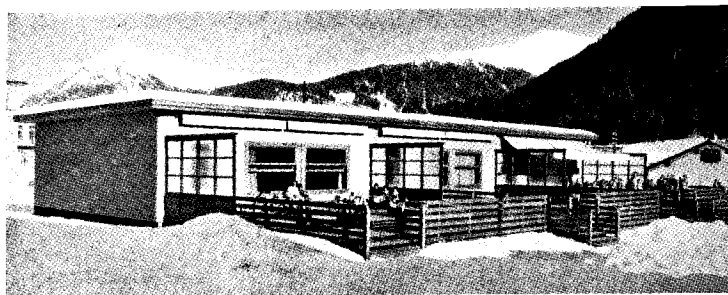

"Das Werk"

The right-hand classroom has been drawn omitting the conventional but needless cloakroom partition; in this way the open floor area is doubled. An otherwise excellent design; note flexible arrangements. Davos, Switzerland. Rudolf Gaberel, Architect.

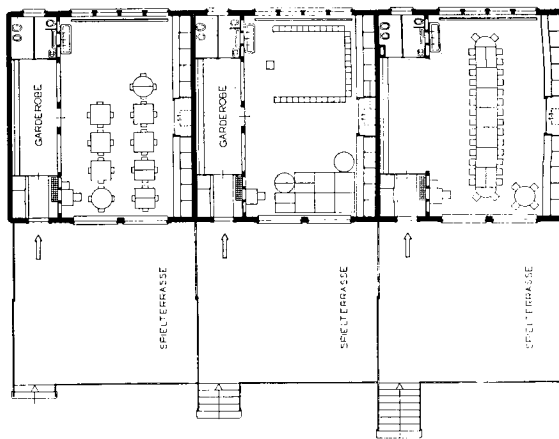

## Changing Clothes

THE NURSERY child's education begins before he ever takes off his coat. Telling him to hang it up places a big problem before a little mind. And how to tie a shoe is more important than many tasks invented by adults.

The facilities in a nursery school for changing and storing clothes are therefore not incidental, but are direct educational equipment of the front rank. They deserve planning with great care.

*Changing clothes takes time:* how much time, only those who have watched can realize. Half an hour or more may pass between the emergence onto the playground of the first fully dressed child and the last. Hurrying the children is fatal to learning.

For this reason if for no other, dressing facilities must be within the nursery room or directly opening from it. Chief item of equipment is the simple coat cabinet: each compartment about 10" deep, 12" wide, 50" high. Each compartment is divided into three sections: the upper, 7" high, for hats; the middle, 28" high, for coats; the bottom, 10" high, for shoes and rubbers.

*It is extremely important for lockers to be open; doors and drawers are both to be avoided.* Both hide what the child needs to see, both encumber action so that children get in one another's way, and both pinch. Learning to manipulate such things, though necessary for everyone, belongs to a later age. Premature forcing, in the interest of "neatness", only delays habits of order by making order much too difficult.

Clever design of clothes lockers, as of all nursery facilities, is design that does away with the repeated necessity of saying "Don't."

For two-year-olds, wire baskets take the place of drawers for storing outdoor clothes, which are too difficult for such small children to hang.

*Places to sit:* for changing shoes a low platform is serviceable. The accompanying illustration is self-explanatory. If the children are to be undressed for sleeping, the washroom for two-year-olds must be supplied with two tables 32" high, and a third on casters to carry children, bundled for sleep, to terrace or rest-room cots.

Right: Open clothes storage, nursery of Cornell University. Wire baskets might be safer than drawers. Below: Such platforms as this (Haus der Kinder, Vienna; Franz Schuster, Architect) are highly useful; can surround columns.



"Moderne Bauformen"

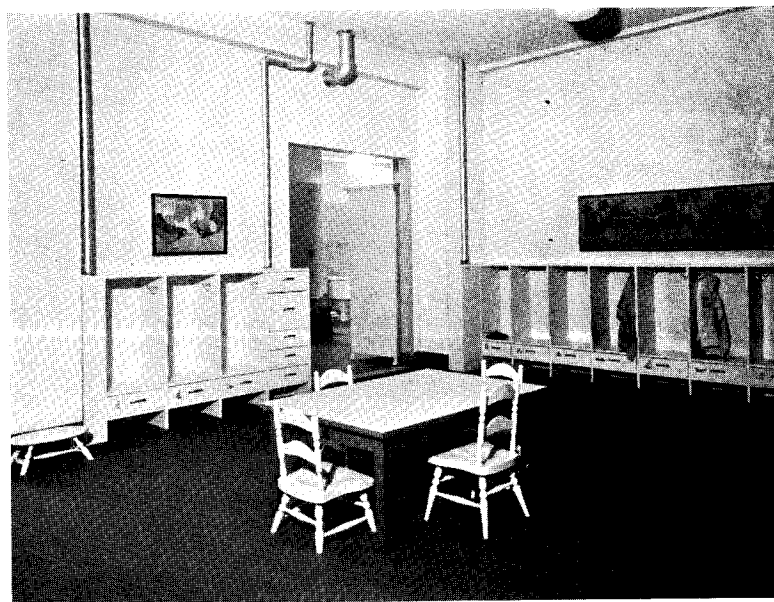

Troy Studio



Troy Studio

Washing, Department of Home Economics, Cornell University. Correct height; rounded surfaces; simple hooks. Use of individual bowls prevents many quarrels. Frederick L. Ackerman, Architect.

### Washing and Toileting

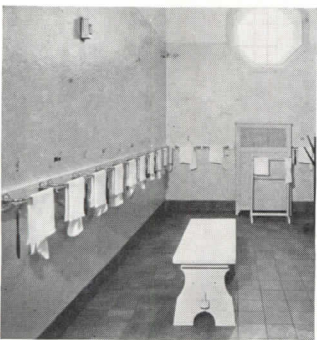

Troy Studio

Left: Toilets and towels at Cornell University nursery. No partitions needed between seats. Hooks might hold towels more securely than bars. Below: In this pleasant school at Glarus, Switzerland, moving the second toilet from its conventional position off the cloakroom would make it easily accessible to the second classroom, saving needless trips by the teacher. Hans Lenzinger, Architect.

TOILETS and lavatory must be directly adjacent to the nursery room and opening into it. No separation of facilities is necessary for boys and girls. Between toilet seats no separating partitions are required from an educational standpoint (see illustration); they are needed only where the community requires them. Two seats to every room are minimal. Typical of good practice, New York State requires a minimum of three stools and basins for every 30 children. Seats, 10" to 11" above floor; washbowls 24" above floor, average. Washrooms for two- and three-year-olds must accommodate the dressing tables mentioned under "Changing Clothes."

Children's towels are individually hung on bars or hooks—hooks preferred for ease. Colored tile or painted emblems enable the child to identify his own. A small open locker holds his toothpaste, has hooks for toothbrush and sometimes washcloth. Bottom, slightly sloping, facilitates drainage and cleaning.

One nursery head complains of washrooms with "port-hole" windows. Washrooms and toilets must receive all possible light.

In nurseries planned for low-income communities, showers and tub are necessary additions.

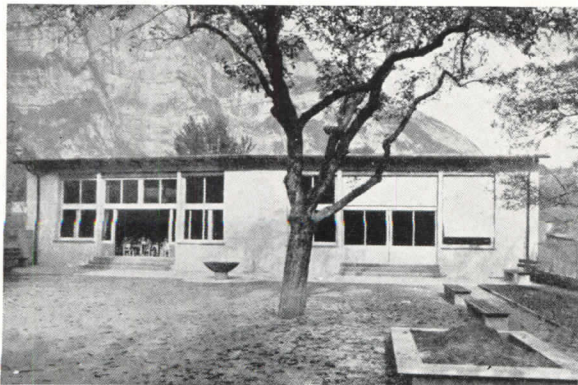

"Das Werk"

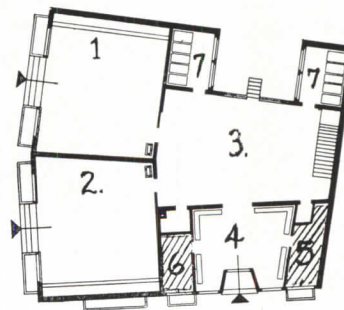

As built

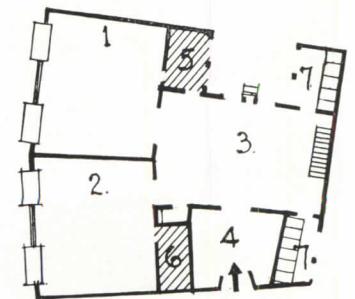

Proposed change

1, 2. Classrooms 3. Play 4. Clothes 5, 6. Toilets and washrooms 7. Cots



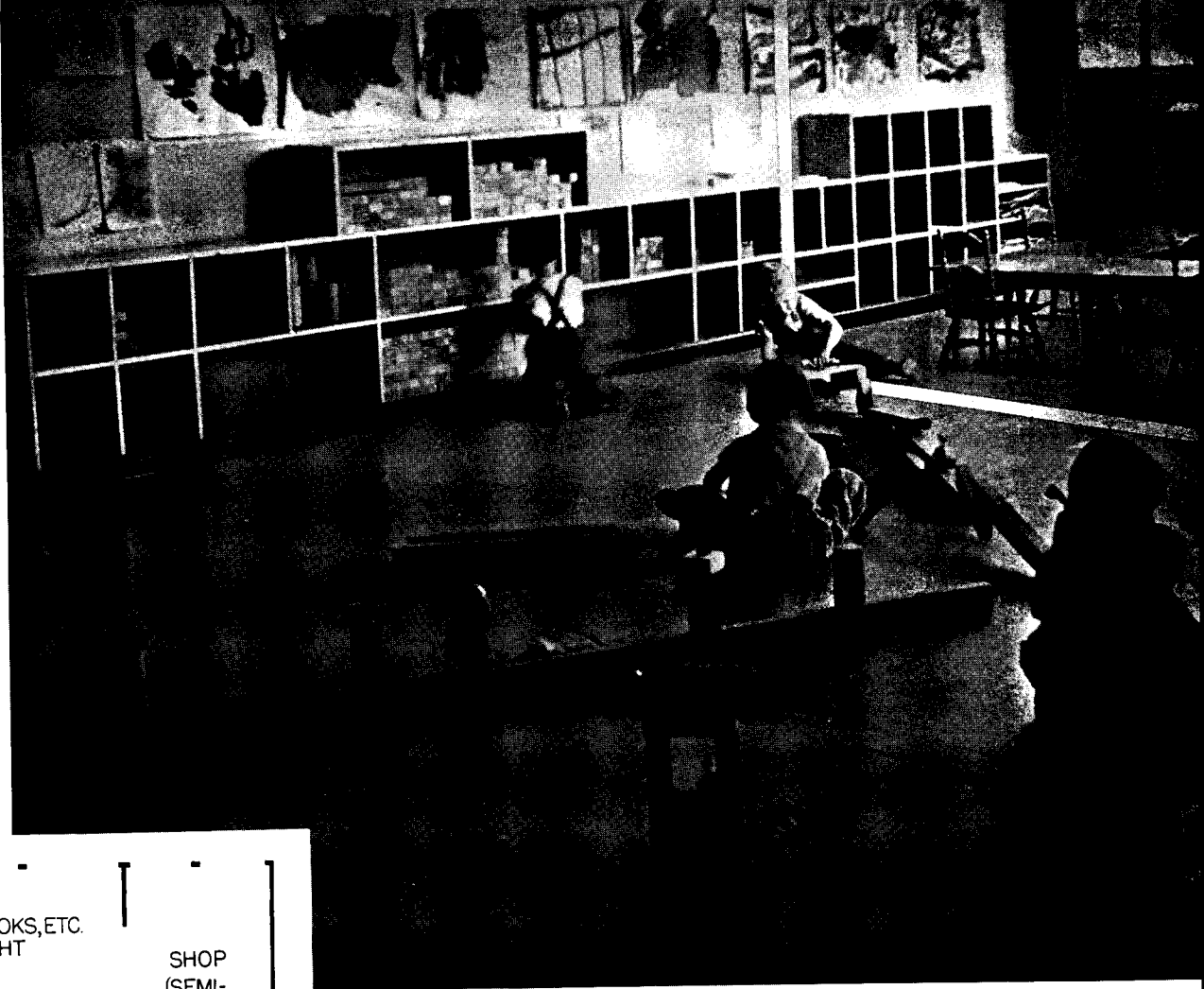

*Helen W. Post*

Diagram shows a nursery room analyzed into areas. Photo shows separation (indicated by the white line) carried out in the Harriet Johnson Nursery School, New York City.

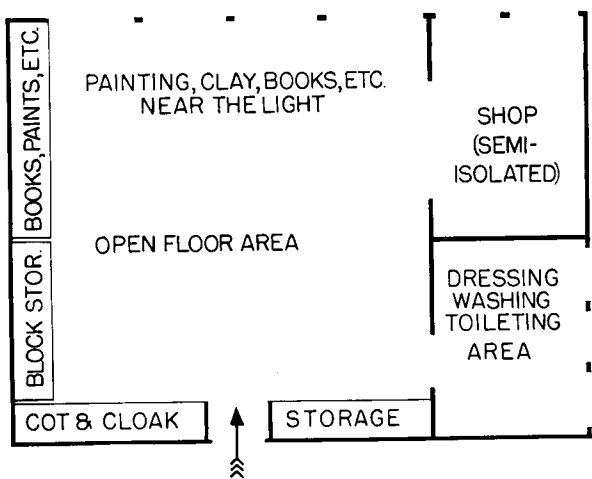

## Indoor Play Areas and Equipment

### Space Requirements

THE NURSERY ROOM divides itself naturally into two main play or work areas.

Fine work, such as painting, clay work, looking at books and the like, requires the best light. Coarse work, such as block building and playing with trains, requires less light but more open floor space. In this area are naturally placed also the slides and other big equipment used indoors only when weather is very inclement.

Above the age of three the children should have a semi-alcove, if possible, for the noisy carpentry shop.

How much space to assign to such activity can only be suggested. Near the light the chief furniture will be chairs, tables, easels. Two favorite table sizes are in use: 23" x 30" if designed primarily for individual children; and 23" x 48" if primary consideration is ease in serving meals (table seats six).

Arrangements of tables and chairs must be flexible.

Architect might suggest that tables joined end to end are most economical of space; a horseshoe or open square is favored as permitting easy use, easy supervision and open floor area in the hollow (see illustration, next page). For chair and for passage space, allow a minimal 3'-6" behind tables.

Easels are of three types: single, double and wall-hinged. Easels are 28" wide and free-standing ones open to 32". Allow 2'-0" standing space for pupil. Easels stand side by side. Wall easels require 2'-6" space out from the wall. A rubber or linoleum pad under the easel protects the floor against drippings.

Clay is handled either on individual tables on bread boards or at a long bench at the window.

When the group plays games, the chairs and tables are often pushed against a wall. It is highly desirable that the total space be big enough so that ample space

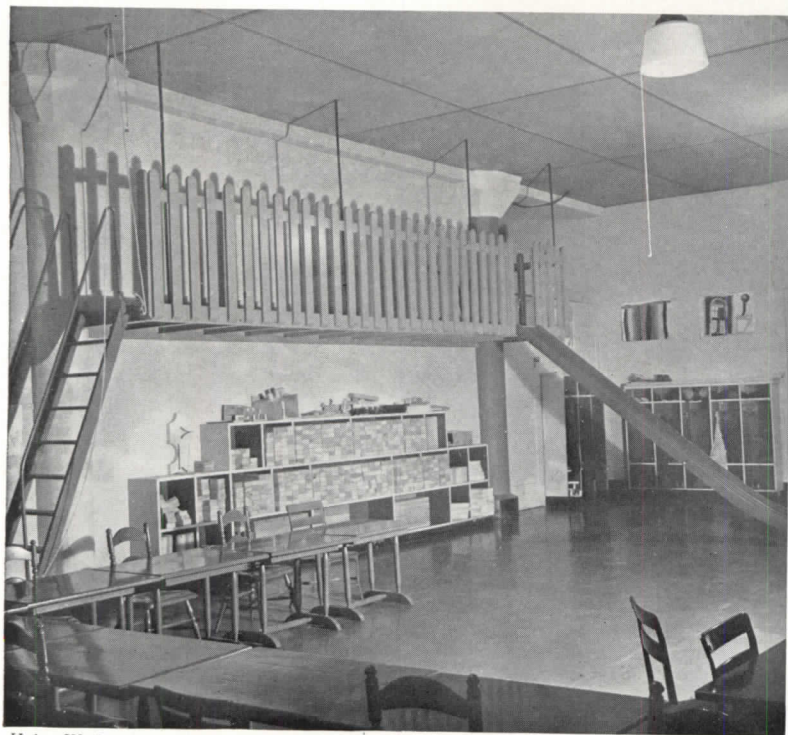

Helen W. Post

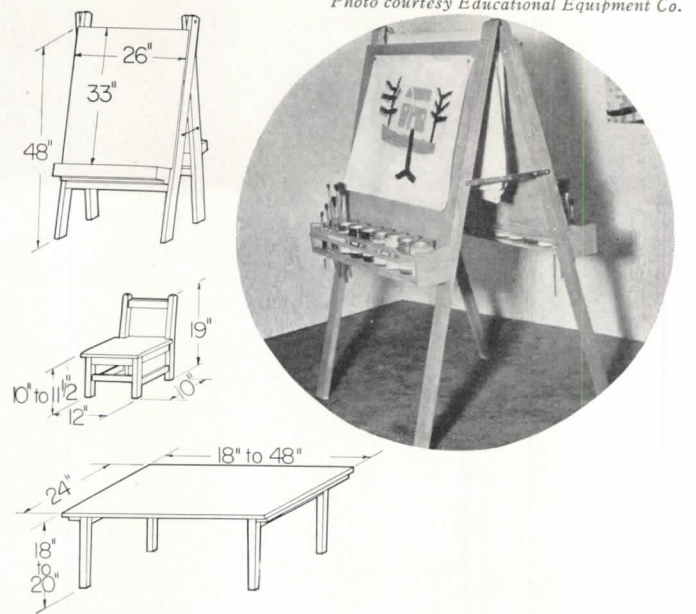

Photo courtesy Educational Equipment Co.

Left: Ceiling-hung indoor slide for rainy days, Harriet Johnson Nursery School, New York. Drawing up the steps on pulleys frees the floor space at other times, and removes the necessity for saying "Don't." Above, easel shows non-spilling rack for paints in jelly jars.

for games can be secured without disturbing block buildings erected on the "Open Floor Area" as marked on the diagram. Such buildings are sometimes allowed to stand for several days when continuity in some project demands it.

Areas to be left clear for "open floor" use are here suggested, with the reservation that variation will be wide. (Hereafter, children will be referred to not as "two-year-olds", three-years-olds", etc., but as "two's" and "three's.") For 10 "two's", 325 sq. ft.; for 12 "three's", 360 sq. ft.; 15 "four's" or "five's", 400 sq. ft.

Unfortunately, architectural journalism cannot honestly be more definite; the astute architect will arrive at his estimates by getting an experienced teacher to put some actual furniture through all possible combinations expected in her routine, on an existing floor.

#### Equipment Storage

Storage must be contiguous to the area of play or there will be hopeless confusion. Books must not be mixed with blocks, paints or doll clothes!

Blocks are an item used by all nursery ages and are bulky in every room. As shown in the illustration above, blocks should exactly fit the compartments provided for them, making disorderly storage impossible, rather than forcing the teacher to prohibit it by "Don'ts."

Dimensions of the standard Caroline Pratt Project Blocks, which are in extensive use, can be obtained through the Educational Equipment Company, 69 Bank Street, New York.

The number of blocks required can be estimated on the basis of the highly useful supply lists of the Harriet Johnson Nursery School, same address, giving quantities and sources for all supplies of all kinds used, re-

spectively, for 10 "two's", 12 "three's", 15 "four's", and 15 "five's." The cost is 25 cents.

*Toys, crayons.* In groups beyond the age of two, each child receives his own cubby or open compartment for his own box of crayons and his toys. Compartments approximately 14" x 14" with a depth of 10" are large enough for ease in the main problem of the child, which is getting things in and out. A color or small emblem identifies his compartment for the child who cannot yet read letters.

The "two's" present a special case. They are very suggestible, and the sight of too many toys at a time is distracting to them. All materials not in use are stored in closed cupboards with high door-latches, and are handed out by the teacher. These include paper, clay, crayons. Accessible toys on open shelves include small wooden dolls, dolls' beds, miniature sadirons, washtubs, clothespins, etc., planned according to quantities in use.

*Paper* is sometimes stored on open shelves, sometimes in the teacher's cupboard, according to ages. The largest common sheet for crayons is 18" x 24". Shallower shelves in the same closed cupboard are better suited for getting out paints (tempera in jars or jelly jars), brushes, extra toys, and the balls, puzzles and other small items that occupy random moments.

The teacher's cupboard is sometimes made with a sloping top on which the teacher, in passing, can make notes for her records. (Height, 4'-0".)

*Heavy Equipment*, such as slides or barrels used indoors when outdoor weather is too inclement, presents a problem in space. An interesting solution is illustrated on this page, with a ceiling-hung balcony and with steps that can be drawn up on pulleys, not only leaving the floor clear at all other times but also assuring the maximum of safety at all times.

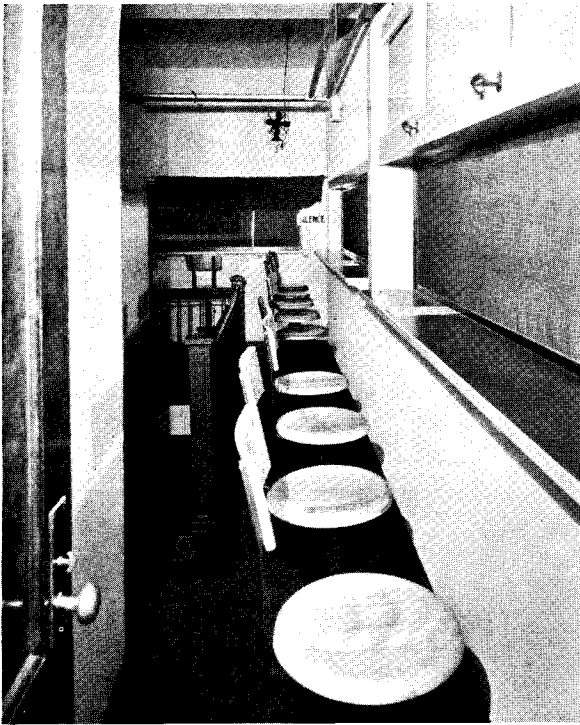

Troy Studio

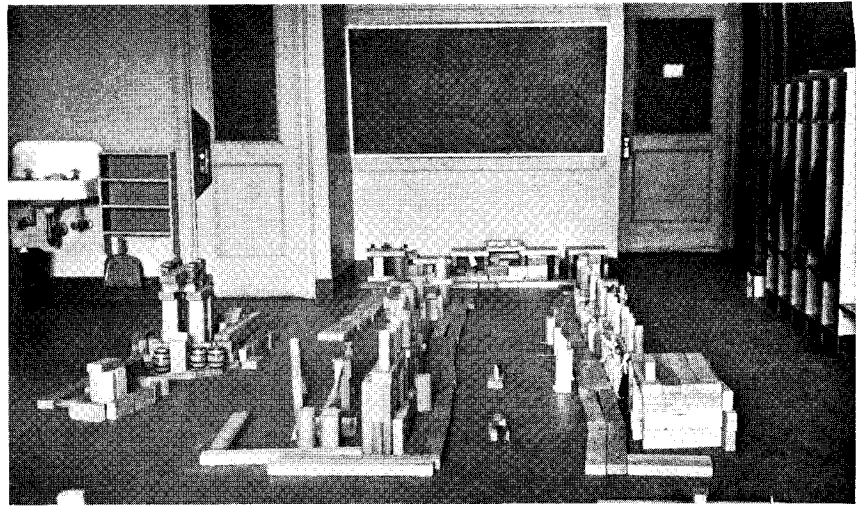

Helen W. Post

Left: An excellent observation booth for student teachers, at Cornell. Observers are made invisible to the children by the simple device of a close-woven wire screen. Note separate access. Right: As such a booth looks to the children (Harriet Johnson Nursery School, New York). In city nurseries the chief use of the booth is for help in demonstrating technique to parents.

## Observation Booth

FOR THE nursery, as for any school, the greatest problem of all is the problem presented by the parents. Parents have fixed but false notions about their own children. Since the child's apparent misbehavior may have been due to something in the parent's own approach, no counter-demonstration can be made by the teacher if the child is aware of the parent's presence.

An excellent solution, available to nursery schools, though not to elementary schools, is the secret observation booth. To the writer's best knowledge this was first used by Dr. Arnold Gesell at Yale University. A simple double screen keeps the observer in the semi-darkened booth out of sight of the children in the room, whereas the children's activities are clearly visible.

The secret booth is of course a highly useful device in the training of novice teachers. Cornell University has made especially effective use of the device—see illustration above.

## Food

*Location of Dining Space.* Rarely does a nursery school build a separate dining room. Either the children eat in their own rooms or one of the playrooms is cleared at noon as a common eating place. If the chief aim is to keep down traffic and excitement, the first method is employed; if the chief aim is to secure the mingling for a short time of all the nursery groups, re-course is had to the second.

Clearing a whole room for common use is more difficult, of course, than keeping the children in their own.

*Equipment* will not be discussed in any detail in this article. Two salient requirements are: first, that the kitchen provide storage room for the restaurant trucks that carry the food to the rooms; second, that chinaware be *light in weight* rather than indestructible, since it will be lifted by very small hands. Trays, also light in weight, should have grips. Orgiastic decoration carries no more dignity for a child than for an adult.



Helen W. Post

Two arrangements for eating. Left: in their own room. Right: in a room specially cleared.

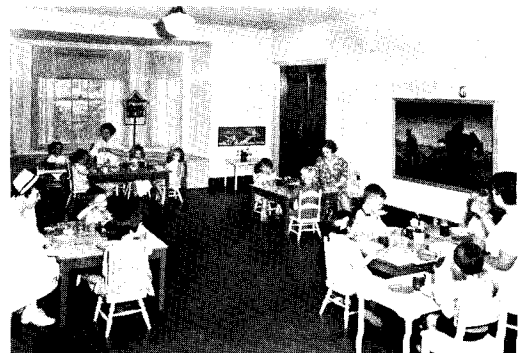

Troy Studio

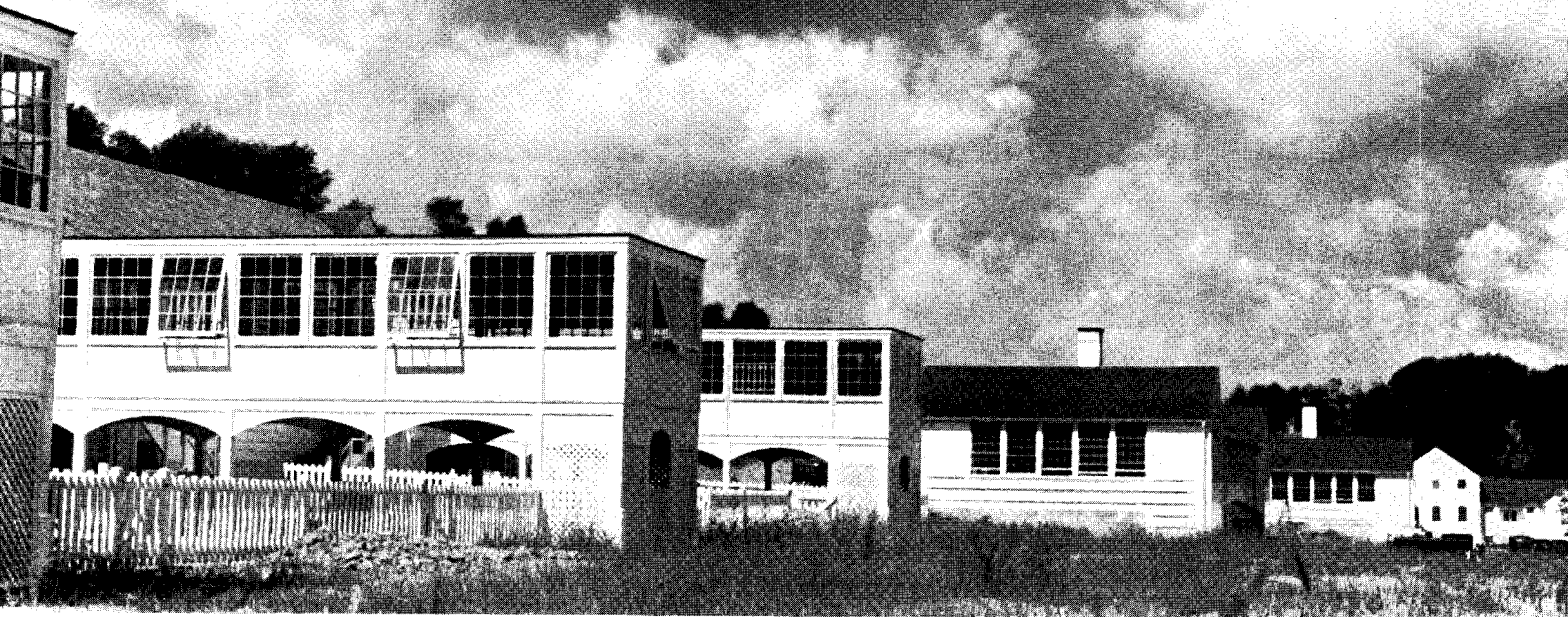

Nursery School at Arthurdale, West Virginia, for Resettlement Administration. Fellheimer & Wagner, Architects.

### ARTHURDALE NURSERY SCHOOL— A Notable Design

THE PLAN of the Arthurdale Nursery School, shown below, may easily come to be considered epoch-making. It is remarkable not for startling innovations but for synthesis. The expedients are tested but the method of combination is new.

For each group of children the plan provides a balanced, complete, and compact environment, consisting of nursery room, washroom, rest room and playground, all closely integrated into one unit. For the child it pro-

vides an environment large enough and varied enough though not baffling. For the teacher it reduces carrying and walking to a minimum.

No other plan examined, European or American, unites so many factors of common sense and ease. Fellheimer & Wagner were the architects, working in close collaboration with Miss Jessie Stanton, a nursery school head who has produced many useful nursery building concepts. The furniture plans have not yet been carried out.

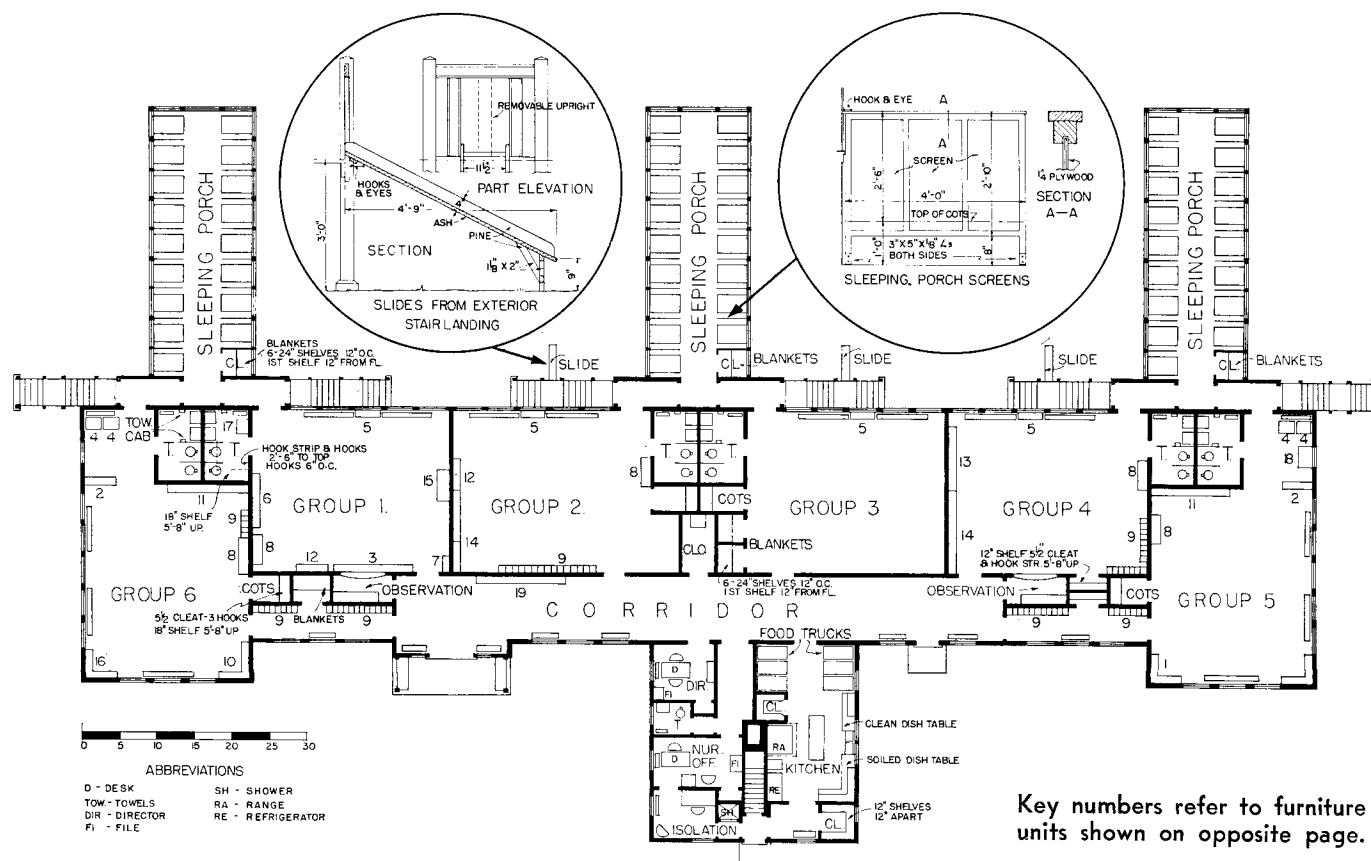

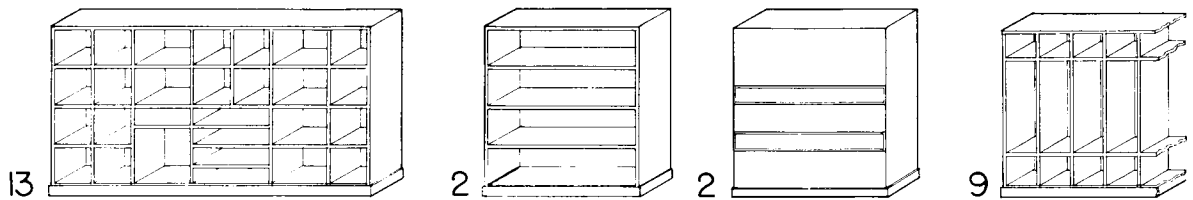
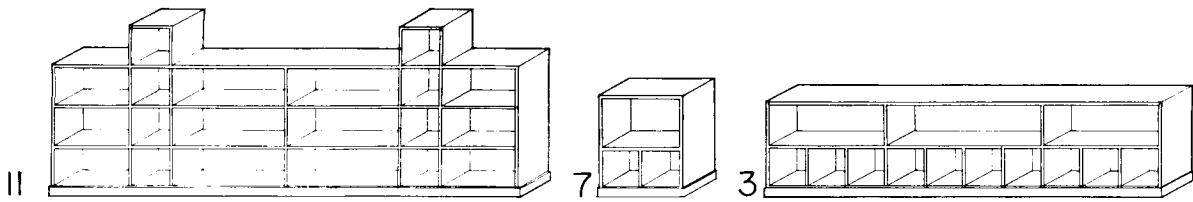

BACK

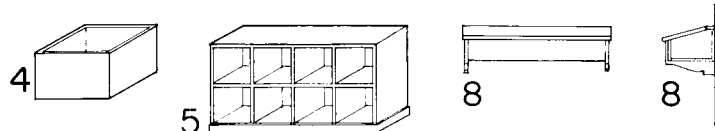
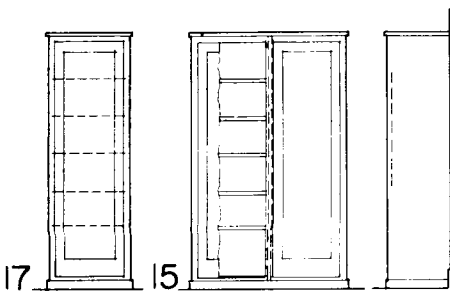
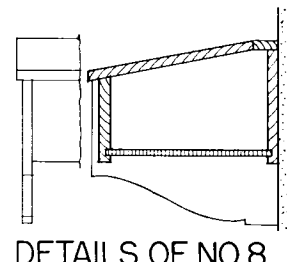
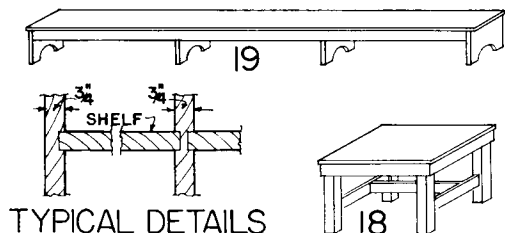
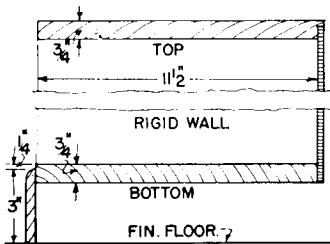
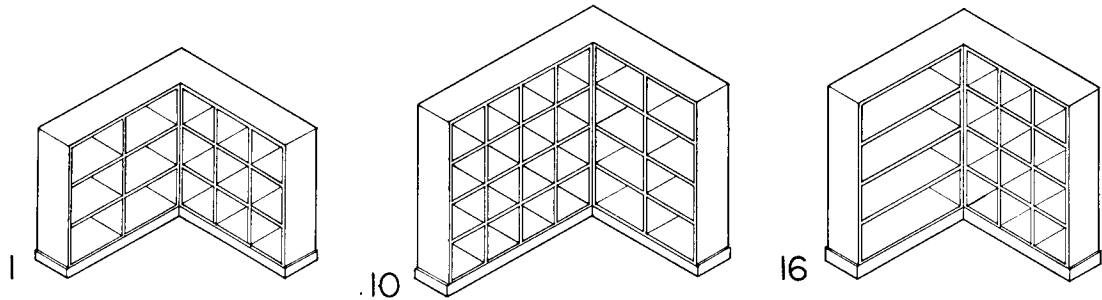
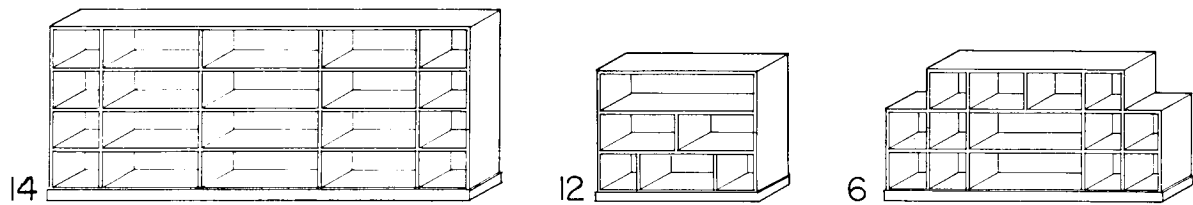

SCALES

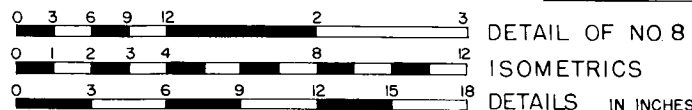

**Suggested Shelving for Materials in Nursery School Classroom**

- 1, 10, 16 Corner shelves for individual crayon boxes, drawing paper, puzzles, books, etc., for children, ages 4 and 5.
- 3, 6, 13 Same type for straight wall space, for children, 3 and 5.
- 11, 14 For sets of blocks (about 800) and related toys such as dolls, animals and automobiles, for children, ages 4 and 5.
- 2 For finished wood products made by children.
- 4 Box to hold lumber.
- 7 A shelf for dolls, irons and other housekeeping toys, to fit space between radiators, for children, age 2.
- 5 Same type for toys, dishes, etc., for children, age 2.
- 12 Same type of shelf, for children, age 3.
- 18 Heavy table to be used for carpentry.
- 8 Teacher's wall desk
- 15, 17 Closets for teachers' coats and storage shelves.

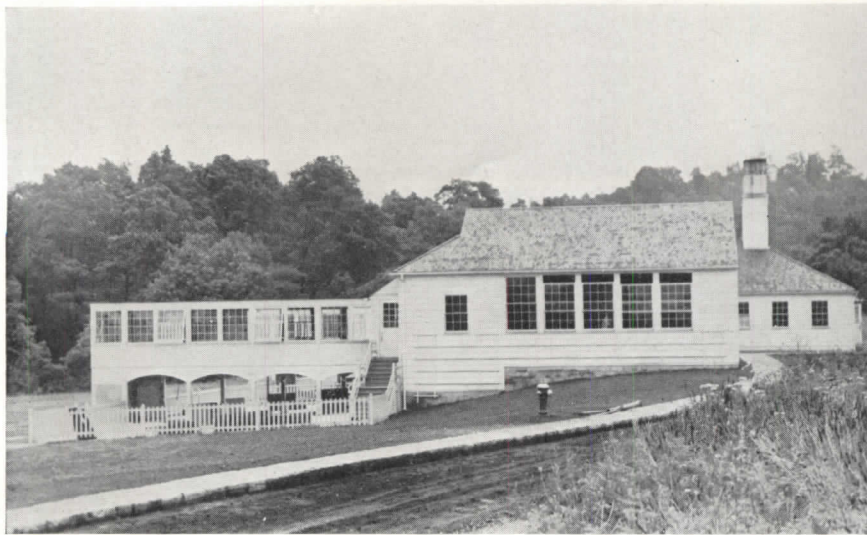

Nursery School, Arthurdale, W. Va., for Resettlement Administration. Fellheimer and Wagner, Architects. Showing sleeping porch at left, administration wing at right. Because of sloping ground, the sleeping porches have been placed over columns, thus forming protected playground areas below, useful in bad weather.

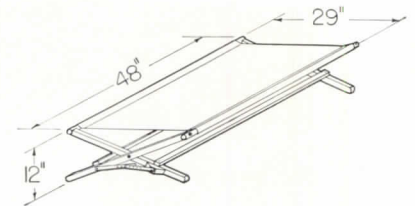

### Provisions for Resting

WHERE BUDGETS are limited, children can be put to bed in their playroom. This, however, is second-best. A separate rest room or pavilion is highly desirable. The children are expected to go sound asleep for at least an hour, if not an hour-and-a-half. It is therefore better for them if they can rest away from the exciting scene of their morning's play.

Pavilions devoted entirely to rest need bear no expense of heating. The children are dressed before being taken out of the warm nursery room. An ingenious device for outdoor rest on a shallow balcony is shown on page 93. These coops have sliding panels that permit adjustment to conditions of wind and sun. The child is placed on the stretcher inside the room and slid out through the window into the coop as if it were an ambulance.

Cots for children up to four years old should measure 27" x 48"; from four to five years old, 27" x 52"; for children five years old to seven, 27" x 54". If used in the playroom, cots must be collapsible, light, easily port-

able, opening automatically without hinges or extra braces; all cots must have rounded corners. Occasionally a sort of pallet is used instead of a cot.

Opaque screens are needed between cots to shut off the children's view of neighbors. A three-panel portable screen, each panel 27" to 30" wide by 36" high, hinged to fold either way, can be placed around the head of alternate beds in a row and will serve effectively that way. Full extension to the foot of the bed, as shown in the photograph, is superfluous and wasteful of storage space. Such screens must be lighted enough to carry but too heavy to be easily knocked over. They find many collateral uses during the day. The light-weight type is for rest-room use only.

*Storage.* Cots and blankets are one item that need not be stored in the nursery room itself. Lockers must be ventilated. A free-standing unit with capacity for 12 cots and blankets is illustrated; for dimensions, see the drawing on page 95.

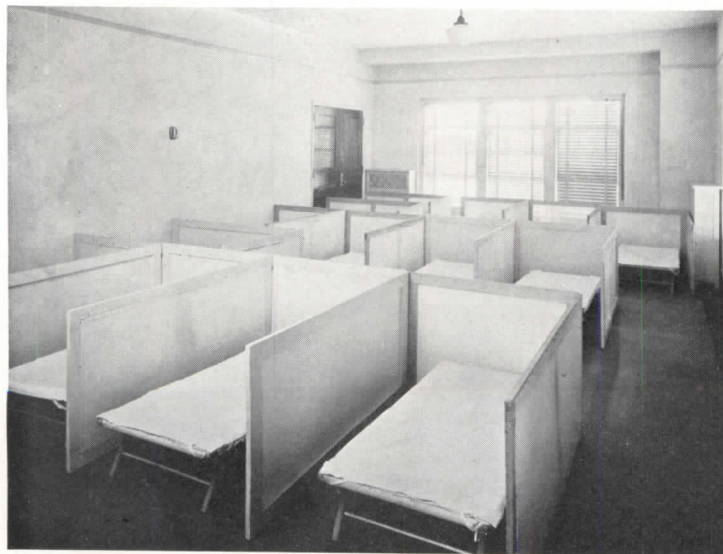

Troy Studio

Left: Sleeping provisions where no special rest room is available (Cornell University). Lightweight cots and screens. Below: Ventilated cot and blanket cabinet. (Note high door handle.) For scaled drawing, see No.'s 15, 17, on the previous page.

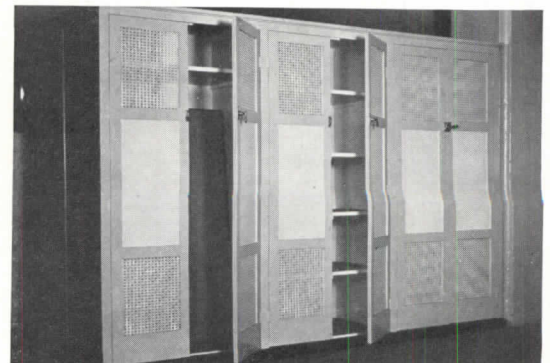

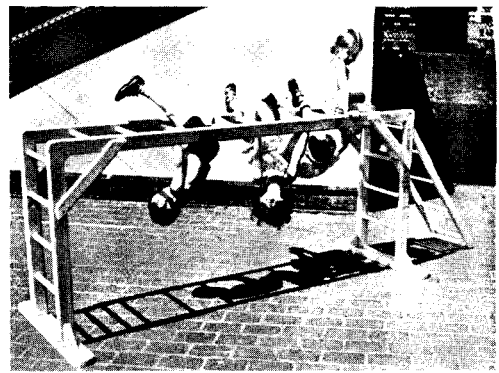
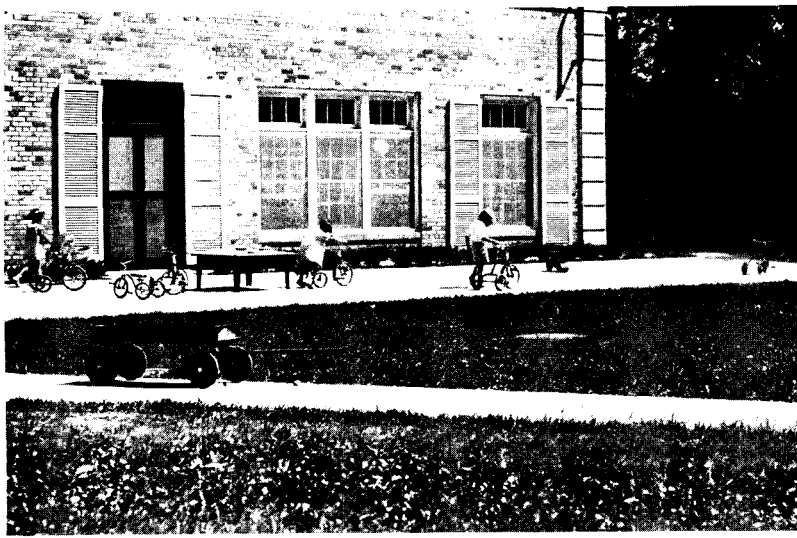

Left: Outdoor Playground, Cornell University, by N. Y. State Div. of Architecture. Concrete pavement adjoining building and looping around play area forms the "scooter circuit."

## Outdoor Playground

*Location.* The outdoor playground should be away from the street and closely accessible to the nursery rooms. Desirable are three degrees of exposure: sunlight, shade and open shelter. In the Arthurdale plan shown on page 94, clever use has been made of the rest pavilions, by setting them over posts to form shelters against bad weather. In the Mexican arrangement on pages 87, 88, the semi-enclosed room opens on a porch that leads to open space: three degrees of openness. Trees in corners are an economical, space-conserving device for shading equipment through part of the day. Sandboxes especially need sun to keep clean, then shade to cool off.

*Size and Arrangement.* Sizes are still empirical. The playground usually divides into three component areas: free play space with soft footing; paved area for play with baby carriages, large blocks, dolls; equipment area with soft or gravel bottom.

National Recreation Association estimates of space for equipment are overgenerous because intended for mixed ages on public playgrounds with little supervision.

The following, from the Association's forthcoming book, "The New Play Areas", by George D. Butler, may be reduced: junior jungle or tower gym, allow 12' by 15'; kindergarten slide, 8' x 20'; chair swing, set of three, 20' x 20'; sandbox, approximately 20 sq. ft. per child: add three feet of free space around the box itself.

To this may be added, parallel bars, 6' x 12'; teeter, 5'-6" x 15'.

Open play requirements vary greatly with age. Important to nursery children is the scooter circuit: a paved walk three feet wide around the periphery of the playground for scooters and bicycles (see illustration). Avoid sharp angle turns.

Do not forget the bird bath.

*The Roof.* In city projects the roof is likely to enjoy better sunlight and air than the ground. Factory fence is used for safety. Because the total area is smaller, it is more important on the roof than on the ground to partition for the different ages, in order to avoid collisions of big and small.

Carts, carriages and trucks are favorite toys of small children.

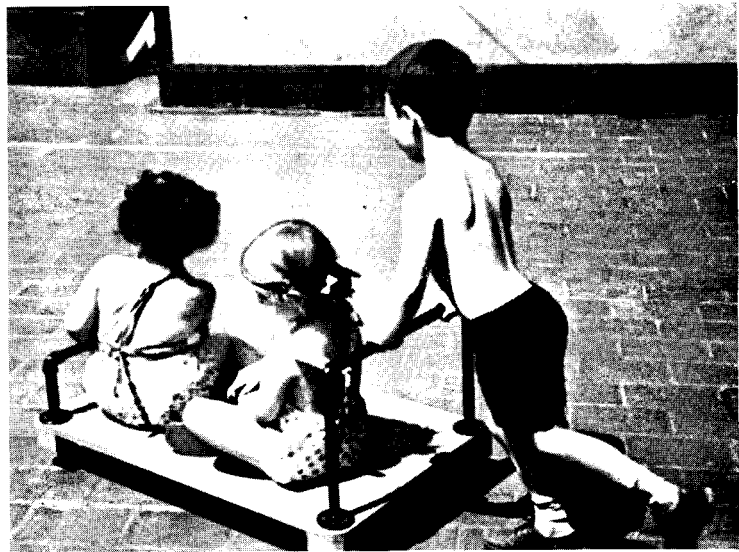
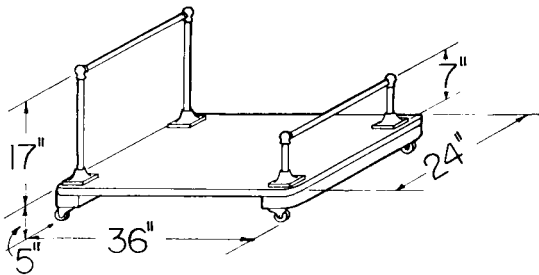

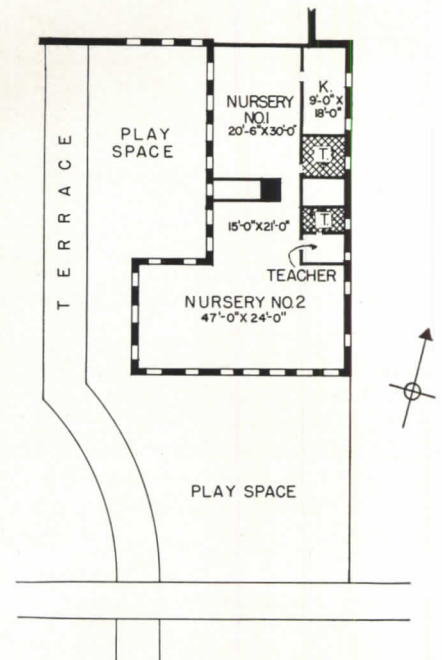

Left: In nurseries connected with housing schemes bathing facilities are often important. "Haus der Kinder", Vienna. Franz Schuster, Architect. Above: Ground-floor plan as exemplified at the Hillside project, New York. Clarence S. Stein, Architect.

## Nurseries in Housing Projects

NURSERIES may ultimately become a government service; in the meantime they are a problem for every large-scale builder, public or private, to solve as best he can. In the case of the expensive apartment, the solution is not difficult, the problem consisting chiefly in determining how many parents are likely to enter their children. Economical nursery operation is possible with any number above ten or twelve.

The low-income housing scheme on the contrary faces a serious economic difficulty, since nursery education, properly conducted, costs more than any other type of education up to college: roughly \$150 a year in the New York area. This is entirely beyond the reach of the people to be housed. At the same time, the very increase in health and virility that accrues to the children in their new improved environment, tends, as the architect Stonorov told the National Association for Nursery Education, to make children yell louder, become a nuisance, and require scope and direction for their activities through playgrounds and nurseries.

The architect therefore needs surveys: (1) of the number of children two to five years old; (2) the proportion of children likely to be sent, as indicated by previous housing schemes in the vicinity; (3) an estimate of cost based on: (a) the degree of education attempted

(staff and equipment); (b) length of the day; (c) serving lunch or not; (d) *available help from the community or operating management*; (e) *help from outside agencies, such as the WPA or kindergarten associations, in paying teachers*. Parents can never be expected to assume the full cost; but they must contribute time and even manual work in helping make and repair equipment; no housing-scheme nursery is possible without some form of parent association. The most successful group in New York has possibly been the one at Sunnyside run by a parents' cooperative.

*The housing type of nursery*, as a result of economy, will be less developed than the full-fledged nursery described on previous pages. At the lowest and undesirable extreme, the nursery becomes a mere parking place for small children. In the economical type, it saves by (a) taking mixed groups; (b) specializing in activities that take a minimum of teacher attention and equipment; (c) allowing all possible time outdoors.

*The location* must be central to the development, requiring a minimum of walking or transportation. The nursery must *not* be close to an elementary school, which would distract and disturb the small pupils. Only two levels of height are permissible: on the ground level opening to a private playground or on the roof. Plans



Right: Nursery School on ground floor, Collective Apartment House, Stockholm, Sweden. *Sven Markelius, Architect.*  
 Below: View and plan of roof-type nursery. Apartment House at St. Pancras, London. *Ian B. Hamilton, Architect.*

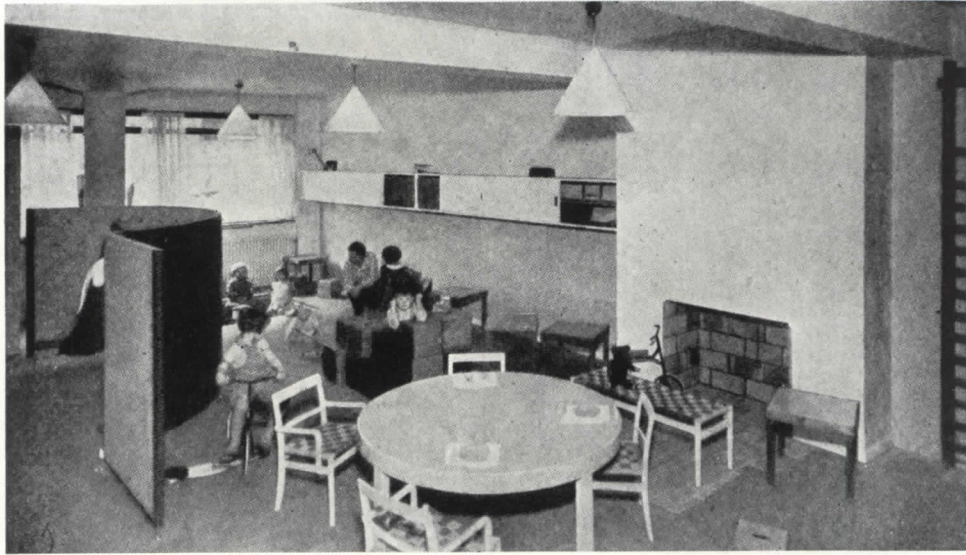

"Architekten"

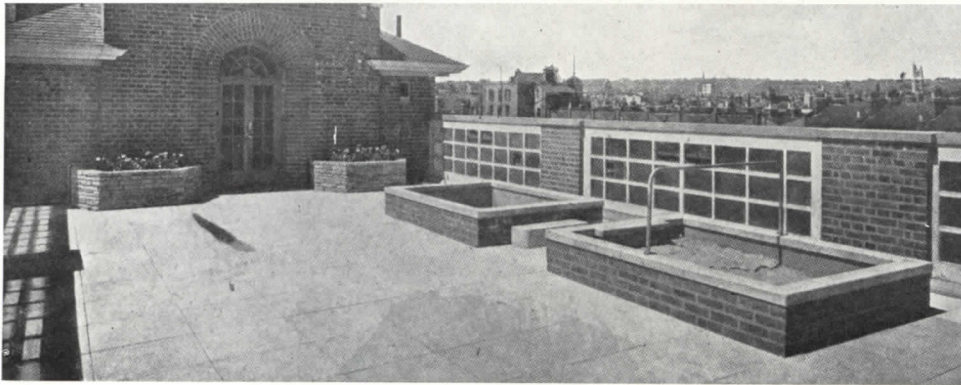

"The Architects Journal"

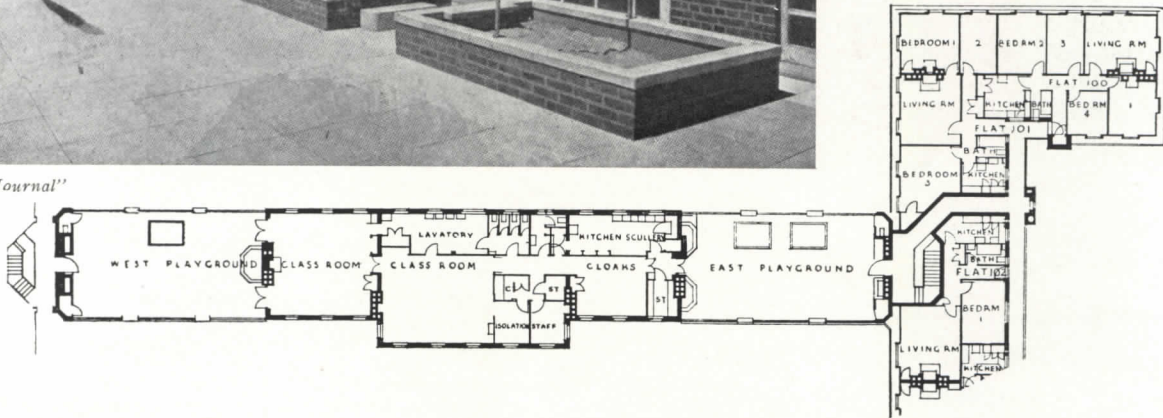

given here represent good solutions at both levels. The roof scheme at St. Pancras, London, a middle-class apartment development, is sound-proofed by the use of stone paving placed on rebated bearers floating on rubber pads; the rooms below have hung ceilings.

Two rooms are standard in such smaller schemes, one for the "two's" and "three's", the other for the older children. The general principles of room organization remain unaltered.

#### Rates in New York City Nursery Schools in Various Housing Developments\*

Development	Management	Children	Monthly All-day	Rates 1/2-day	Other Help
Amalgamated, Bronx	Community	30-40		2.00	New York Kindergarten Association pays for teacher.
Paul Lawrence Dunbar Nursery School Kindergarten	Community	15	6.50		New York Kindergarten Association pays for teacher.
	Community	30	free	free	
Jackson Heights Cambridge Court Community Georgian Hall	Private	35	11.00	6.00	Management supplies playground and play-rooms.
	Private	70	10.00	5.00	
	Private	30	40.00		
Phipps Apartments	Private	25	7.50	6.00	Management supplies room and equipment.
Sunnyside Park Group Play School Progressive School	Private	10		4.00	Community allows space in Park. Child Study Association helps with funds.
	Community	137	8.00	6.00	
	Parents' Co-operative	55	25.00	15.00	

\*Data collected by the office of Clarence S. Stein, Architect. February, 1935.

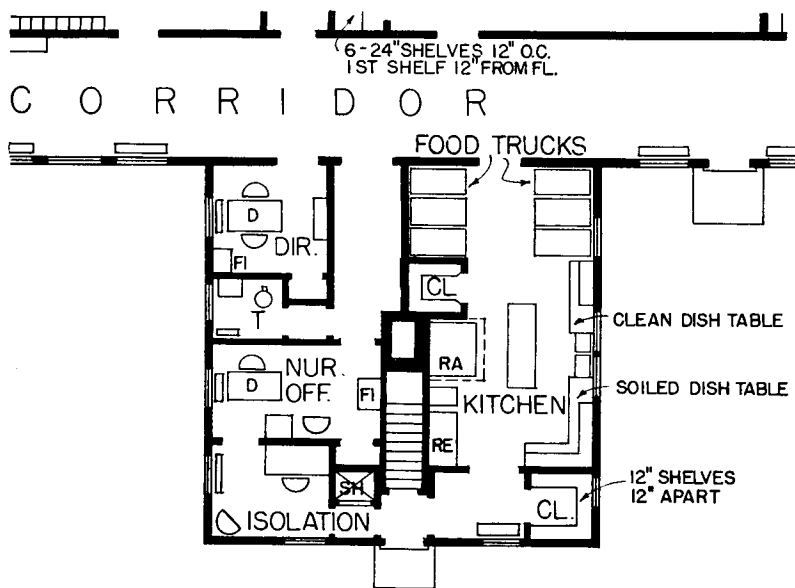

Part of plan, showing administrative unit. Nursery School at Arthurdale, West Virginia. Fellheimer and Wagner, Architects.

### Administrative Unit

AMONG administrative facilities the first is an entryway or hall large enough so that children waiting for bus or car will not be crowded. Undue noise at this point as a result of crowding will make an impression on visitors so bad as to undo the effect of the nursery's good work.

The director's office must, as a minimum, provide desk

and file space; much better is the addition of a reception room with desk for a secretary.

The nurse's office need not be large, giving room for the nurse's desk, first-aid supplies, scales and a cot; a washbasin is desirable; this office must have direct access to toilet and lavatory.

In the Arthurdale plan reproduced here, the isolation room is well placed, being connected both with the nurse's office and the kitchen. Such a room is for children neither ill enough to go home nor in good enough spirits to play with the other children. Nursery heads recognize that what laymen call "naughtiness" is usually a product of fatigue or irritated nerves requiring quiet and lack of excitement. A nursery head reports that her architect misinterpreted the term "isolation" to mean punishment and therefore placed the windows high where the child could not see out; the isolation room must on the contrary be pleasant and soothing.

The kitchen should be large enough to prepare the single hot meal at noon, which is wheeled into the rooms on restaurant trucks.

Staff lockers and toilet are more likely to be thought of than the provision of a retiring room for the staff. No job in all industry is more wearing than that of nursery teaching well done. Considering the low pay for which nursery teachers generally work, the provision of one quiet room where they can snatch a few moments is a minimal decency.

Sanitary facilities not to be forgotten are the usual broom closets and slop sinks; storage is needed in hallways for extra cots, blankets, supplies of paper, clay, paints and the like.

### Sources

#### 1. Books on Nursery Education

- Parents Look at Modern Education. Winifred Bain.
- Nursery Education. Blatz, Millichamp and Fletcher.
- Children in the Nursery School. Harriet Johnson.

#### 2. Pamphlets and Periodicals

- Regulations Governing Classes and Schools for Children Two to Seven Years of Age. Also, Policies Governing Interpretation of Regulations. University of the State of New York, Education Building, Albany, N. Y.
- Nursery Schools. Works Progress Administration Release No. 4-1521.
- Equipment Used in a Class of Ten 2-Year Olds; ditto Twelve 3-Year-Olds;—Fifteen 4-Year-Olds;—Fifteen 5-Year-Olds. Mimeographed (25 cents each), Harriet Johnson Nursery School, 69 Bank Street, New York City. This material is very useful, furnishing not only complete lists but also sources of supply.
- Science in the Nursery School; also The Sand Table; etc. Publications of the Industrial Arts Cooperative Service, 519 West 121 St., New York City. This organization is a teachers' cooperative and a useful source of disinterested information on sources for educational supplies.
- Apartment House Design to Meet Family Needs. Robert L. Davison. Architectural Record: Vol. 67, pp. 267-88. March, 1930.
- Nursery School Equipment and Budget. Grace Langdon.

Columbia University. 1929. Suggestive, though conditions have greatly changed.

Catalogue. Educational Equipment Company, 69 Bank Street, New York City. (25 cents). This company has pioneered modern nursery-school furniture and equipment under direct guidance of nursery educators. Gives useful dimensions. Another source of useful information is the American Seating Company, 1776 Broadway, New York City.

Nursery-Infant Schools. Architects' Journal, London. Dec. 16, 1937.

Two Blocks of Flats, St. Pancras. Architects' Journal, London. Sept. 16, 1937.

Current Notes on Planning: Schools. Architect and Building News, London. Oct. 16, 1936.

Nursery School, Brondesbury, N W. Architect and Building News, London. Dec. 17, 1937.  
1937 volumes of *Das Werk, Arkitekten, Bauformen*. American Seating Company, 1776 Broadway, New York City.

### Acknowledgements

Grateful recognition is extended to the following educators for assistance: Miss Jessie Stanton, Head, Harriet Johnson Nursery School; Miss Marie Belle Fowler, Head, Department of Family Life, Cornell University; Dr. Lois Meeks, Professor of Education, Columbia University; Dr. Mary Dabney Davis, U. S. Bureau of Education; Dr. Ruth Andrus, Director, Child Development and Parent Education Bureau, University of the State of New York; Professor James Mendenhall, Columbia University; Clarence S. Stein, Architect; George D. Butler, National Recreation Ass'n.; and others who graciously gave time and advice.

# PORTFOLIO SUPPLEMENT

FROM AMERICAN ARCHITECT AND ARCHITECTURE

## Rain Leader Heads



Wurts Bros.

House in Flushing, New York.

John Oakman, Architect



1

2

*Richard Averill Smith*

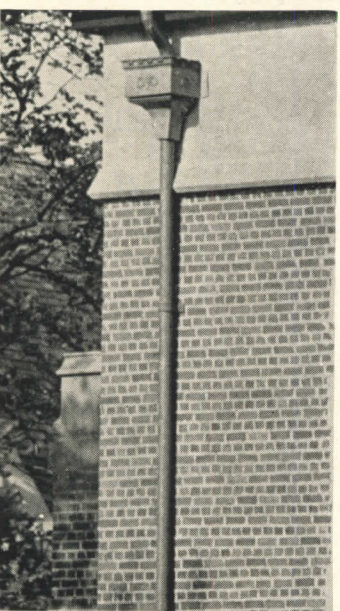

3

4

*John Wallace Gillies Inc.*

*Mattie Edwards Hewitt*

5

*Wurts Bros.*

- |    |                                      |                                  |
|----|--------------------------------------|----------------------------------|
| 1  | House in Bronxville, N. Y.           | Lewis Bowman, Architect          |
| 2  | Faculty Building in Princeton, N. J. | Aymar Embury II, Architect       |
| 3  | House in Golden's Bridge, N. Y.      | Lewis Bowman, Architect          |
| 4  | School in Dayton, Ohio.              | Schenck & Williams, Architects   |
| 5  | House in Greenwich, Conn.            | W. L. Dominick, Architect        |
| 6  | House in Greenwich, Conn.            | I. N. Phelps Stokes, Architect   |
| 7  | Estate in Sandspoint, N. Y.          | Ward & Walker, Architects        |
| 8  | House in Darien, Conn.               | Wesley S. Bessell, Architect     |
| 9  | School in Santa Fe, N. Mex.          | Gordon F. Street, Architect      |
| 10 | House in Detroit, Mich.              | E. L. Confer, Architect          |
| 11 | School in Bell, Calif.               | Train and Cressy, Architects     |
| 12 | House in Greenwich, Conn.            | Allan Taft Squire, Architect     |
| 13 | House in Abington, Pa.               | Leigh French, Jr., Architect     |
| 14 | House in Scarsdale, N. Y.            | Electus D. Litchfield, Architect |



6

Wurts Bros.

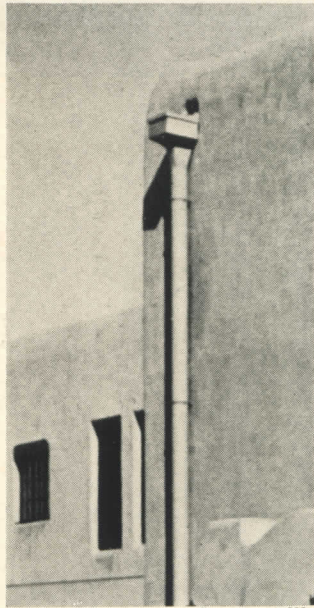

9

Courtesy PWA

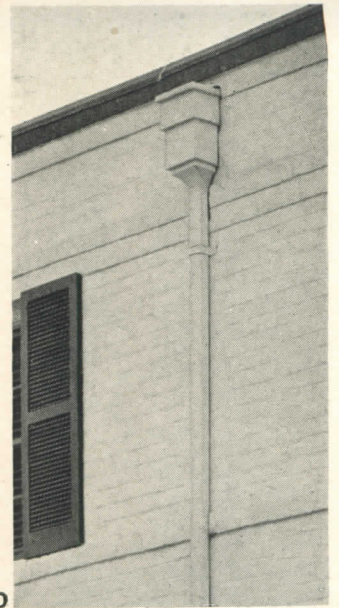

10

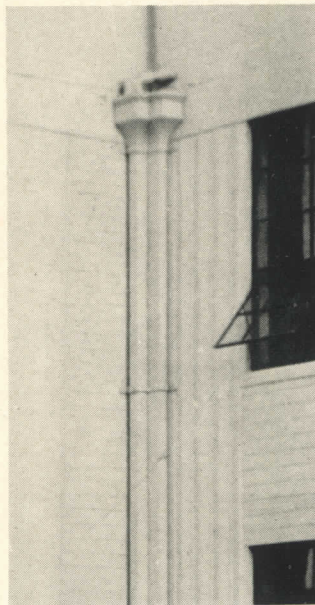

11

Courtesy PWA

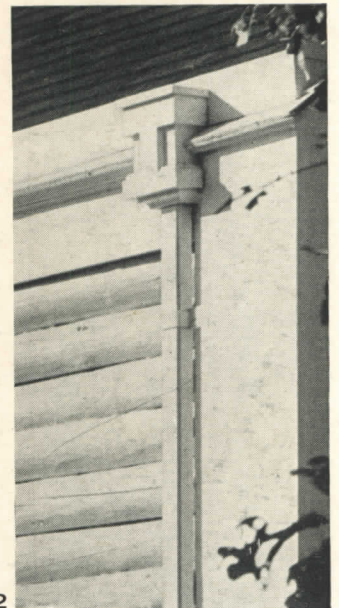

12

Gottscho



7

Wurts Bros.

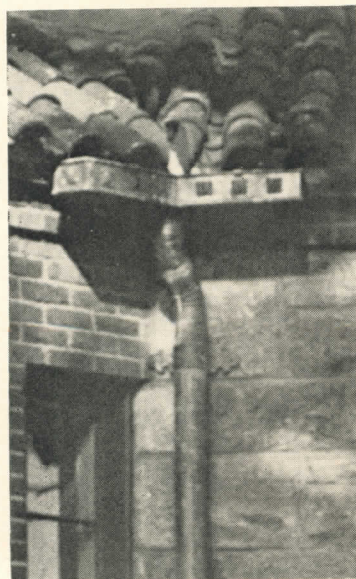

8

Henry F. Saylor

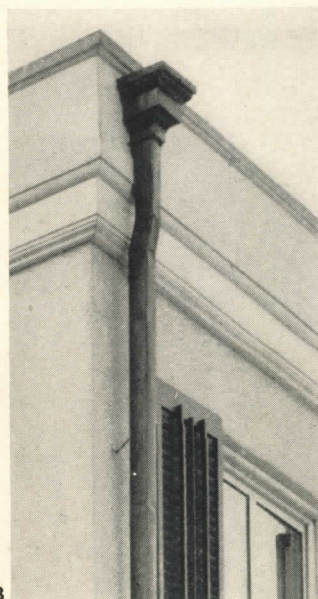

13

Ewing Galloway



14

Gottscho

Richard Averill Smith

Richard Averill Smith

Gottscho

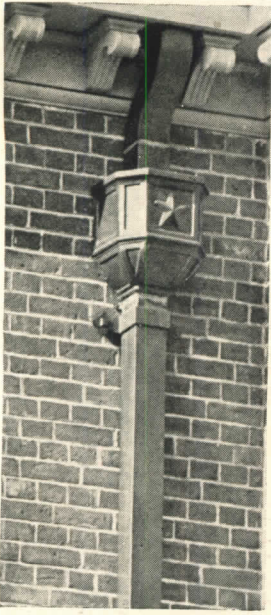

1

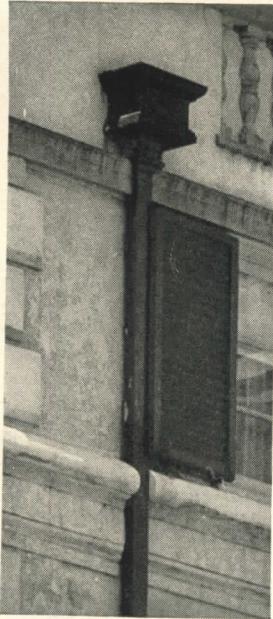

2

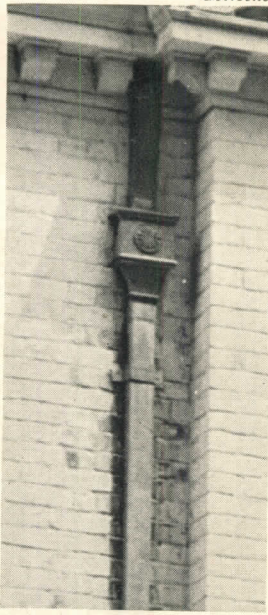

3

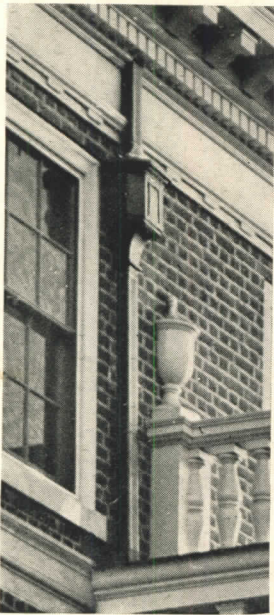

4

Courtesy PWA

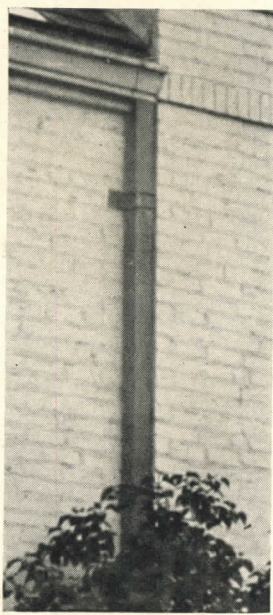

5

Van Anda



6



7

Richard Averill Smith

- 1 House in New Rochelle, N. Y. Frederick G. Frost, Architect
- 2 Club in Princeton, N. J. Aymar Embury II, Architect
- 3 Library in Long Meadow, Mass. Smith & Bassett, Architects
- 4 Apartment House in Blacksburg, Va. Corneal, Johnson and Wright, Inc., Architects
- 5 House in New Haven, Conn. Douglas Orr, Architect
- 6 School in Chappaque, N. Y. James Renwick Thomson, Architect
- 7 House in Alpine, N. J. Aymar Embury II, Architect



8

Gottscho

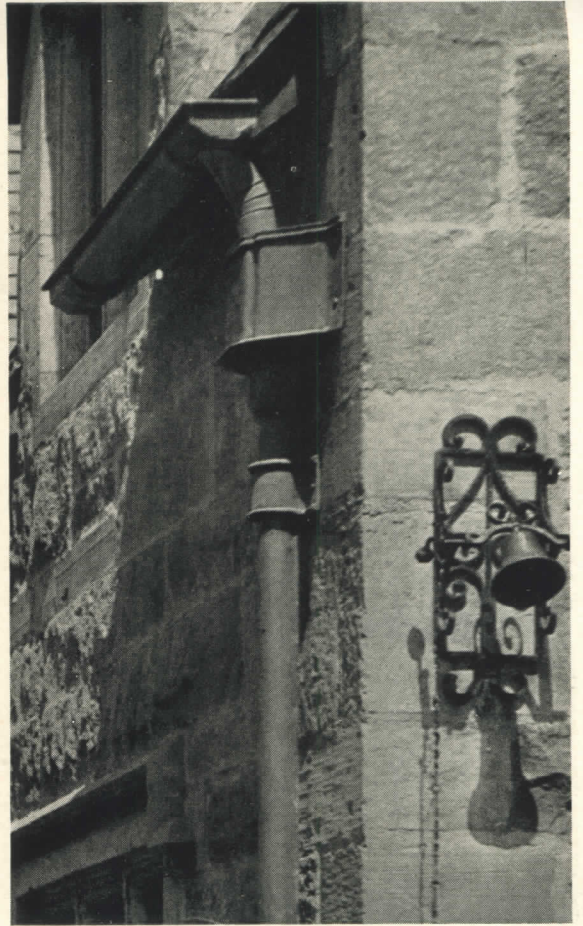

9

Van Anda



10

Wurts Bros.

- 8 House in Norfolk, Conn. Taylor and Levi, Architect
- 9 Estate in Glen Head, N. Y. Roger H. Bullard, Architect
- 10 House in Locust Valley, N. Y. Bertram G. Goodhue, Architect

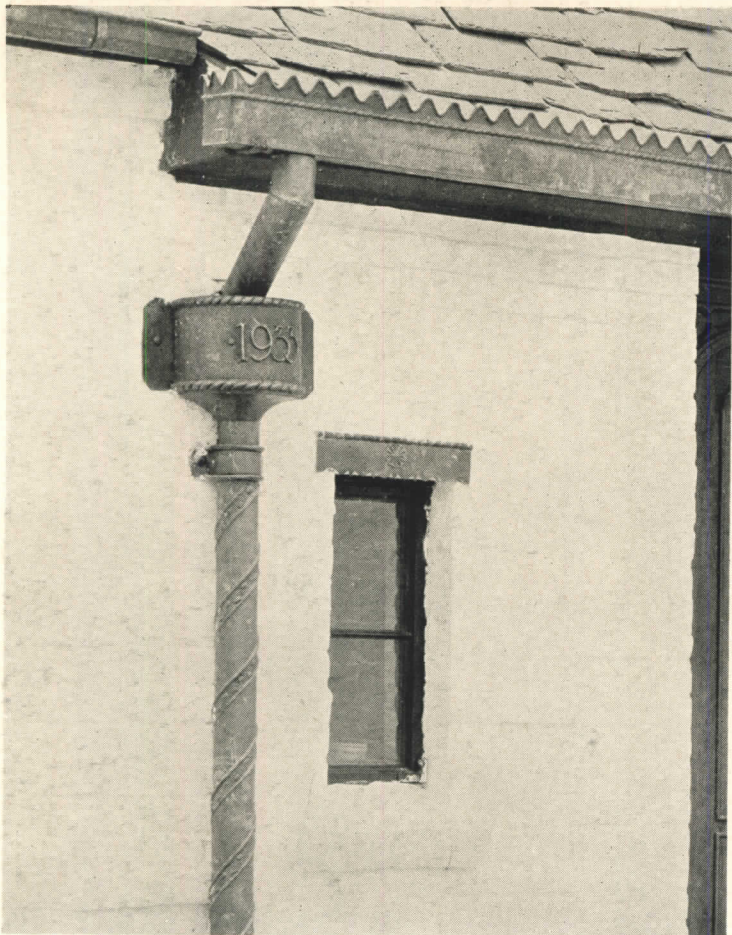

1

Wurts Bros.

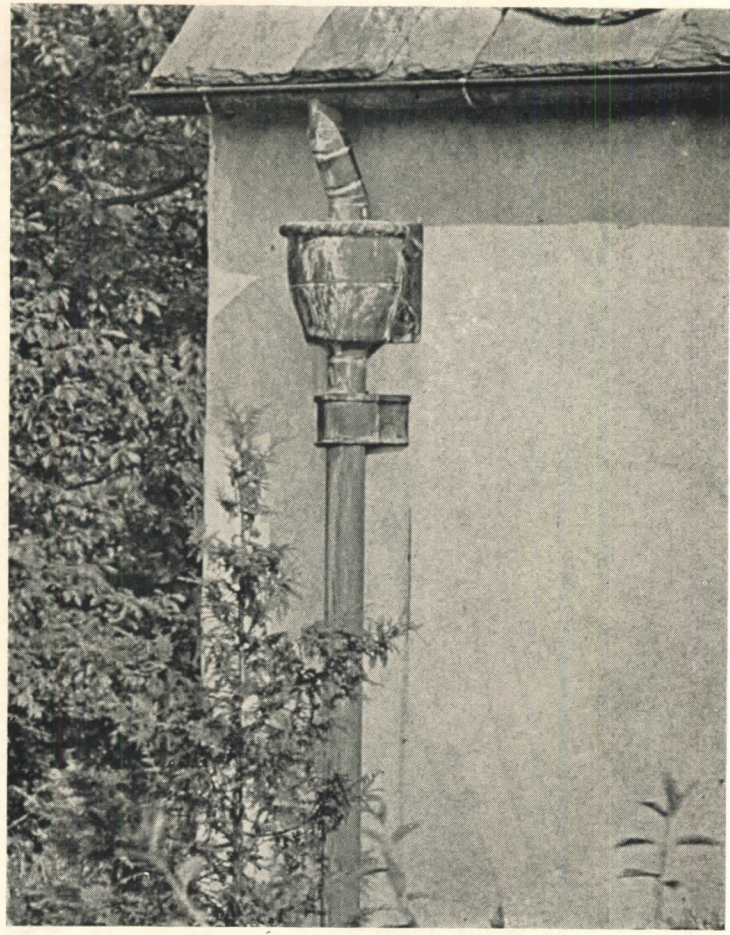

2

Richard Averill Smith

- 1 House in Glen Head, N. Y. Fred Solpwedel, Architect
- 2 House in Far Hills, N. J. Bernhardt Muller, Architect
- 3 House in New Rochelle, N. Y. Walter A. Pleunthner, Architect
- 4 House in Atlanta, Ga. Hentz, Adler & Shutze, Architects
- 5 Club in Glen Ridge, N. J. Dans, McGrath & Kiessling, Architects
- 6 House in Pelham, N. Y. Piiny Rogers, Architect
- 7 House in Greenwich, Conn. I. N. Phelps Stokes, Architect
- 8 Fire House in Glen Head, N. Y. Cherry Matz, Architect
- 9 House in Greenwich, Conn. I. N. Phelps Stokes, Architect
- 10 House in Locust Valley, N. Y. Polhemus & Coffin, Architects

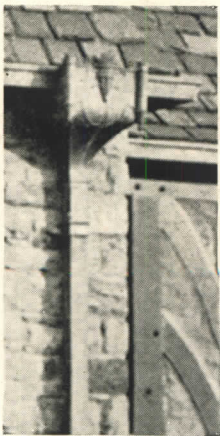

3

Richard Averill Smith



4

Tebbs and Knell, Inc.

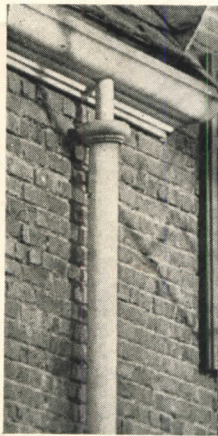

5

Mattie Edwards Hewitt



6

Richard Averill Smith



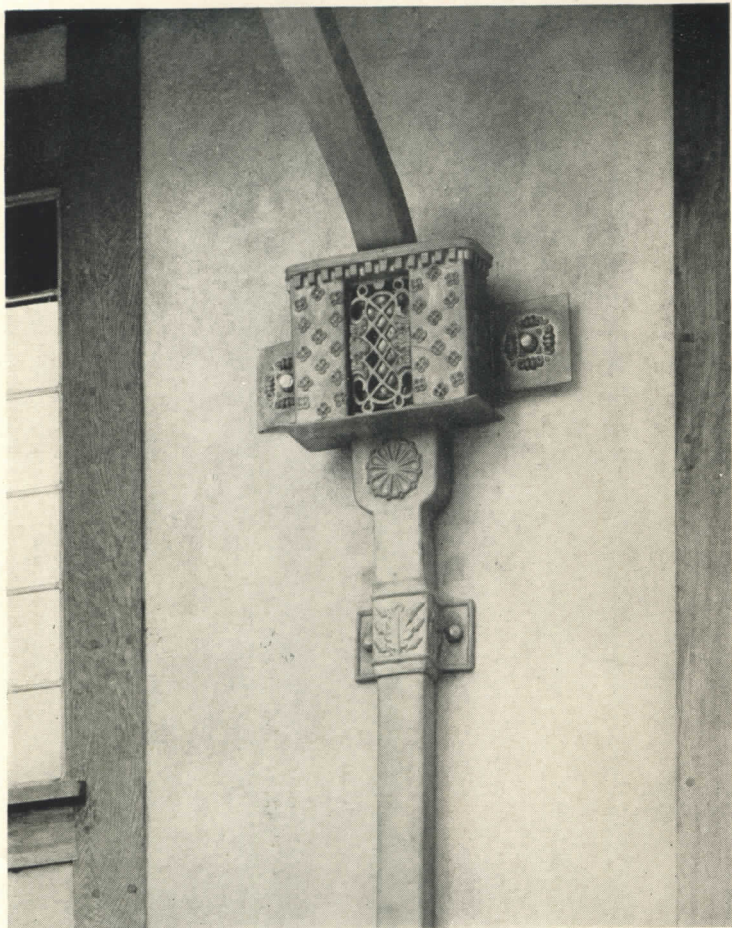

7

Wurts Bros.



8

Wurts Bros.

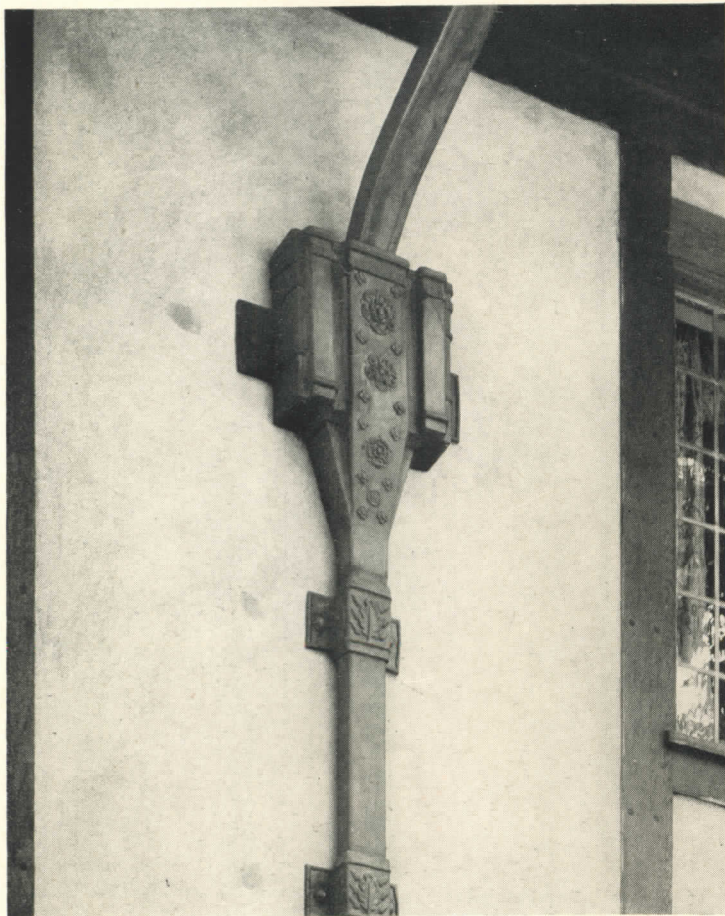

9

Wurts Bros.



10

Wurts Bros.



1

*Wurts Bros.*

- 1 Estate in Sands Point, N. Y.  
Ward & Walker, Architects
- 2 House in Spring Hill, Ala.  
G. B. Rogers, Architect
- 3 Faculty House in Princeton, N. J.  
Park & Morgan, Architect
- 4 School in Chapel Hill, N. C.  
Atwood and Weeks, Architects
- 5 Sterling Laboratory, New Haven,  
Conn.  
William Adams Delano, Architect
- 6 Asthall Manor, Oxfordshire, England  
Charles E. Bateman, Architect
- 7 Cemetery in Brooklyn, N. Y.  
Warren & Wetmore, Architects

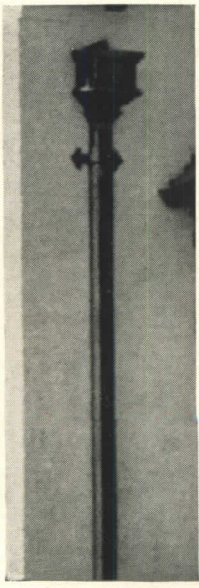

2

*Tebbs and Knell, Inc.*

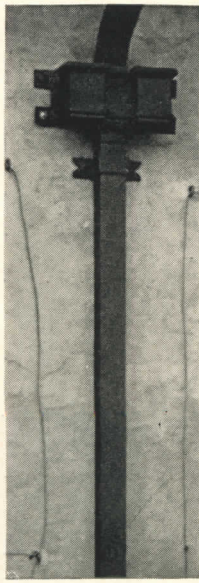

3

*Mattie E. Hewitt*



4

*Courtesy PWA*

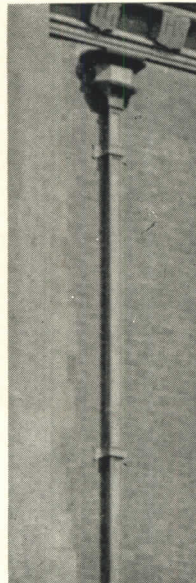

5

*Mattie E. Hewitt*

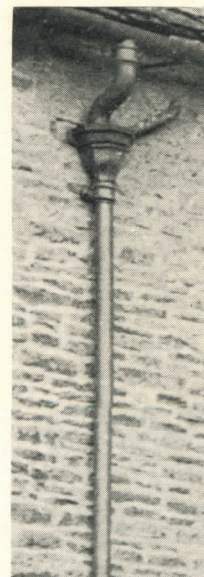

6

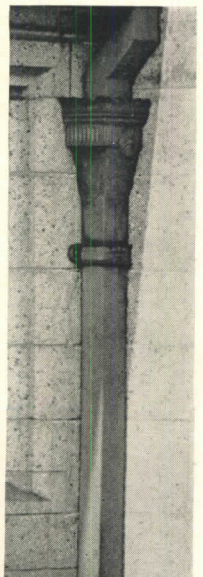

7

*Wurts Bros.*

# Preventing Condensation in Insulated Structures

By TYLER STEWART ROGERS

New facts about the use of thermal insulation in walls and roofs of buildings, which show how to prevent hidden condensation, are presented in this important article based on recently concluded research.



Courtesy University of Minnesota

ARCHITECTS, owners and research technicians have observed, in recent years, a small but growing number of buildings in which dampness or frost has developed in walls, roofs or attic spaces. Most of these were insulated houses, a few were winter air-conditioned. The erroneous impression has spread that insulation "draws" water into the walls and roofs.

But probably several million houses standing today are insulated and only a small percentage have developed chronic dampness conditions. Among these, some have shown frost and ice formations sufficient to cause minor structural damage; others have shown only indications of dry rot or fungus growths in wood members; and the majority have only evidenced moisture through stained plaster or what appeared to be a leaky wall or roof. Why should so many insulated buildings experience no condensation problem; and why, among the relatively few evidencing dampness, should there be such wide variation in effects?

Obviously, insulation is not at fault—at least not alone. Nor could winter air conditioning, creating comparatively high and sustained relative humidities for health, be charged with sole responsibility, for not all structures reporting dampness were equipped with humidifiers. The need for research became apparent: a need which was reviewed in the article, "Insulation—What We Know and Ought to Know About It", in *American Architect and Architecture* for November 1936.

## New Information

In consequence of this situation two important research projects were carried on in 1937 which have profound significance to every architect and building owner. Both reached identical conclusions. Both found the cause, the cure and effective means of preventing condensation in both new and existing structures!

It is now clearly established that conditions which favor the formation of condensation within walls and

roofs in cold weather are produced by a combination of high relative humidity indoors with weather stripping, effective insulation and certain arrangements of structural and finishing materials generally considered to represent good-quality, weathertight construction. These conditions were rarely found in combination 15 or 20 years ago and condensation problems were then unknown, except in icehouses and certain industrial plants. Today they are becoming more common because all of the contributing elements—humidification, reduced infiltration, weathertight construction and efficient insulation—are highly desirable in terms of health, comfort and economy.

New principles governing the correct assembly of building materials and the use of insulation have been developed which are applicable to all commercial types of insulation in use today and to all types of construction in which they are appropriate. They have the merit of extreme simplicity. They seem so logical that one wonders why they were not obvious long ago.

Data on the research work which produced these significant findings may be found in: (1) "Condensation in Walls and Attics" by L. V. Teesdale, senior engineer, Forest Products Laboratory, Madison, Wisconsin, published in the fall of 1937 as a U. S. Forest Products Laboratory report; and (2) "Condensation Within Walls" by Professor F. B. Rowley, A. B. Algren and C. E. Lund of the Engineering Experiment Station, University of Minnesota, presented as a paper before the meeting of the American Society of Heating and Ventilating Engineers, January 25, 1938.

This article and the accompanying Time-Saver Standards sheet (Serial No. 102) constitutes the first report to the architectural profession of the results found by these investigators. Technical data have been omitted and the conclusions and suggestions of the research authorities have been interpreted and developed, so far as it is consistent to do so, in terms of practical applicability to present-day problems. Every effort has been

made to verify these interpretations, to the end that they correctly reflect the knowledge so far gained. Both research projects are being continued, and further knowledge of great value may be expected in subsequent reports (particularly relating to the properties and behavior of specific materials). But there is little expectation that any important deviation from the underlying principles emphasized in this article will be discovered.

Certain basic factors contributing to the formation of condensation in building structures must be clearly understood if the full significance of the new developments is to be appreciated. These factors include the sources of dampness in vapor form, the natural movement of this vapor, the range of temperatures within walls, and the characteristics of building materials in relation to vapor movement. In combination these factors cause condensation or prevent it, according to the manner in which they operate together.

#### **Sources of Dampness**

Ordinary processes of living tend to add a considerable amount of moisture to indoor air in winter. Cooking, washing, the operation of shower baths and the escape of steam from radiators are obvious sources. Evaporation from house plants and loss of body moisture by perspiration are less obvious, though measurable.

If there is a frequent interchange of indoor and outdoor air by filtration through cracks around windows and doors or by other means, this excess moisture is rapidly dissipated until there is a balance of normal humidity and vapor pressure, indoors and out. This was common in houses built a generation or two ago and accounts for the extremely low relative humidities often experienced indoors in old houses in very cold weather.

If this natural interchange is prevented by tighter construction, including the use of weather stripping, caulking, heavy waterproof building papers and other desirable practices designed to increase indoor comfort and reduce heat losses, there is an increase in relative humidity and vapor pressure indoors that creates an unbalanced condition between the cold and the warm side of a wall or roof. When this natural moisture is supplemented by evaporation from a humidifying device operated to maintain healthier and more comfortable conditions, there will develop a further difference in vapor pressure between the two sides. These unequal pressures tend naturally to seek a balance; hence the vapor on the warm side (under higher pressure) tries to move through the intervening construction to the cold side (where vapor pressure is low). This vapor movement is quite independent of air movement. ( See Figure 2.)

Most building materials are permeable to vapor, including plaster, wood, brick and ordinary building papers, even though they may be excellent wind stops. Therefore, the vapor under higher pressure indoors will move more or less freely through these materials when it cannot take the easier path of direct air leakage. This moisture can readily reach the interior of ordinary walls and roofs from within the building.

#### **The Refrigerator Experiment**

A dramatic demonstration of this tendency of vapor

to move from warm to cold areas was made at Toledo, Ohio, under the direction of Jan S. Irvine before inaugurating the research program at the University of Minnesota. An ordinary steel-cased domestic refrigerator was dismantled and the waterproof wrappings removed from the insulation in the sides, top and bottom. The unprotected insulation was restored, the cabinet reassembled and then water was poured into the insulated spaces through holes drilled in the steel shell for the purpose, until the insulation was thoroughly saturated. These holes and all joints, seams and the door gaskets were then hermetically sealed with gums and asphalt so that moisture could neither enter nor escape. But between the inner lining and the insulated spaces the usual breather holes were left clear.

Within seventy-two hours after the refrigeration machine was put in operation the insulation was bone dry! All the water had accumulated on the chilling unit inside, in the form of ice and frost. Here was clear proof that water, taking the form of vapor, would move toward a colder area if any passage were available.

#### **Temperature Changes**

What happens to this vapor that moves from the warm inside air, through the plaster or woodwork and into the interior of the wall or roof?

The warm side of a building wall is usually exposed to air approximately 70°F. in winter, while the outside air may range downward to temperatures well below zero. Between the two surfaces of the wall or roof sections the temperature ranges between these extremes. The temperature drop varies according to the thermal conductivity of the materials and air spaces forming the section. (See Figure 3.)

If the outdoor temperature is below the dew-point temperature of the indoor air, there must be some place within a wall or roof where the water vapor working through toward the outside will tend to condense into fog or dew. (The dew-point temperature, of course, varies with the relative humidity and dry-bulb temperature of the air; it is that temperature at which the air is fully saturated by the vapor present, and below which some of the vapor is condensed and precipitated).

Consequently in cold weather there can be condensation within the walls of a heated and humidified structure, if *vapor is allowed to enter from the warm side and cannot escape.*

#### **Where Condensation Occurs**

From the refrigerator experiment it is obvious that water will evaporate (i.e., turn to vapor) and move to colder areas under the force of unequal vapor pressure, if not wholly confined. Therefore, if condensation takes place at all, it must occur on *some sufficiently cold surface that impedes free movement to the outer air.*

This theory was confirmed in experiments of both Rowley and Teesdale. If frost occurred at all in insulated walls, it was always observed on the inner face of the outside sheathing, not in the fill insulation itself. In fact, at the low temperatures used by Professor Rowley, the insulation was drier after the test than when installed. Presumably if outside temperatures were above freezing so that dew rather than frost appeared, it might

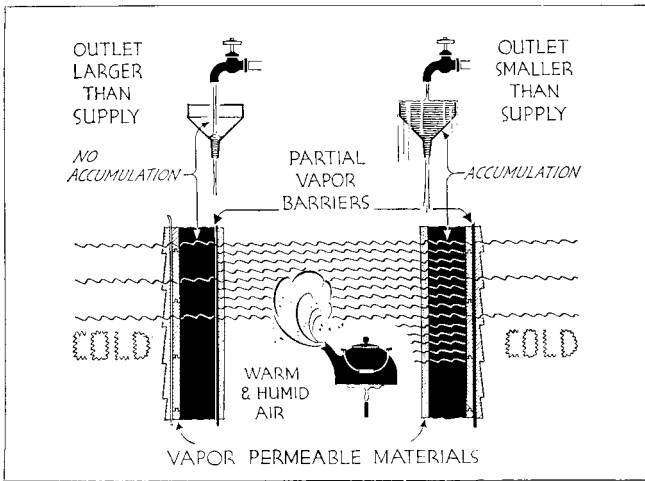

Figure 1: DEMONSTRATING THE VAPOR BARRIER PRINCIPLE. If water flows into a basin which has an outlet larger than the supply, no water accumulates (left); but if the outlet is restricted (right), water fills the basin and overflows. So with walls and roofs. If a barrier to the movement of vapor (which can pass through most building materials) is placed on the warm side (left diagram), little or no moisture can reach the colder regions where it might condense. Furthermore, what little vapor passes the barrier will continue through the less resistant materials to the cold outside air. But if a barrier exists near the cold side (right), it stops the vapor from within where it accumulates and is exposed to low temperatures; hence condensation or frost forms in cold weather. If the vapor barriers were perfect, the result would be comparable to shutting off the faucet over the left-hand basin, or blocking the outlet of the right-hand basin.

spread as dampness into adjacent insulation, but it would not tend to remain unless its further movement to the cold air were blocked.

While both investigators employed mineral wool fills in order to get maximum thermal resistance in the air space and thus test extreme conditions, it is obvious that the same basic principles hold true for other forms and applications of insulating materials and for uninsulated structures. The dew-point temperature will be found nearer to the inside surface of the wall if the greatest insulating effect is located there, or nearer the outside of the sheathing if the latter is the primary insulator and causes the greatest drop in temperature near the exterior.

#### The Vapor Barrier Principle

From these observations three facts stand out clearly: (1) Condensation cannot occur in walls or roofs unless vapor can penetrate from the warm side to the region within the construction where the dew-point temperature of the air within the wall exists. (This temperature may not be the same as the dew-point temperature of the indoor air and its location cannot be precisely determined with present knowledge, but the matter is not important to this discussion).

(2) If vapor does penetrate to the critical dew-point temperature area, it will tend to move as vapor toward the colder outer air, and will condense only on some

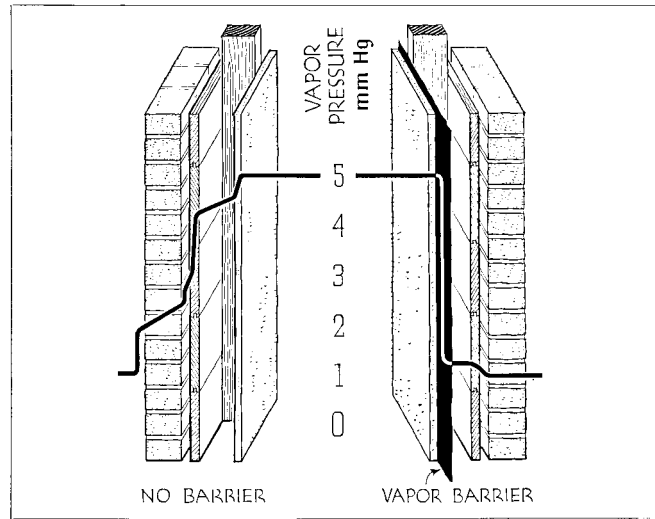

Figure 2: VAPOR PRESSURES IN WALLS. The weight of water vapor in air exerts pressure which tends to move vapor from air that has more water content to air that has less. This vapor pressure is measured in millimeters of mercury (Hg). Approximate changes in vapor pressure between the warm, humidified air usually present in occupied buildings in winter and the pressure out of doors on a typical winter day are shown above. The pressure gradient lines show also the relative rate of vapor movement. Note that a vapor barrier (at right) stops most vapor movement and reduces the pressure nearly to that of the cold outside air. Compare with the temperature gradient lines of Figure 3. (Drawings based on data from Kimberly-Clark Corporation).

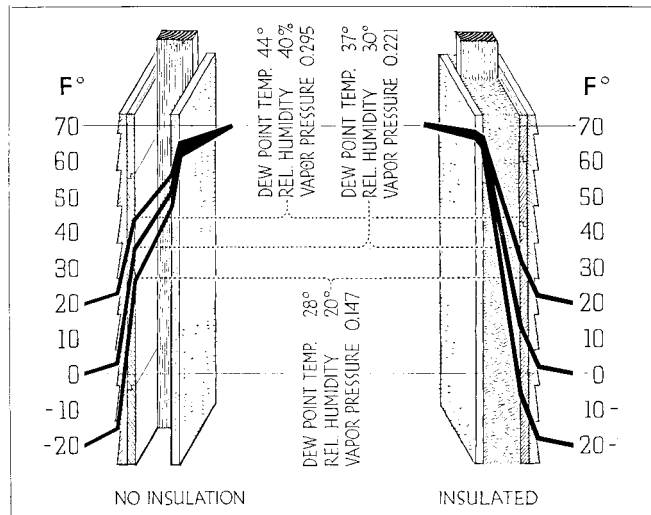

Figure 3: TEMPERATURES IN WALLS UNDER VARIOUS CONDITIONS OF INDOOR HUMIDITY AND OUTDOOR TEMPERATURE. Solid lines show temperature gradients in an uninsulated wall (left) and an insulated wall (right) for 70°F. indoors and 20°F., 0°F. and -20°F. outdoors. The dotted lines give critical data for three different indoor relative humidities. Theoretically, condensation would occur where the solid lines cross the dotted lines if vapor pressures did not cause a flow toward the cold outdoor air. Actually condensation does not take place until a cold surface is reached which retards vapor movement. If permeable materials or ventilators are provided on the cold side, water may remain in the state of vapor without condensing. (Diagrams from L. V. Teesdale.)

cold surface or barrier that impedes its progress to the area of minimum vapor pressure.

(3) Dampness or frost will therefore develop and accumulate only when it is easier for vapor to reach this resistant condensing surface than for it to continue its natural movement toward the colder outside air.

In these three facts we can find satisfactory solutions of the condensation problem.

From the first it is obvious that steps should be taken to prevent vapor on the warm side from entering the wall or roof structure far enough to cool and condense. A barrier to the entrance of vapor on the warm side of the construction will alone prevent condensation.

From the second and third it becomes clear that no barrier to the movement of vapor should exist on the cold side of the wall or roof; or if there be one, by reason of weatherproofing or structural requirements, that it should be less resistant to vapor movement than another barrier on the warm side. Any vapor that passes the warm barrier will then continue its outward movement more freely than it entered; therefore it will not tend to accumulate. Ventilation on the cold side of the dew-point region becomes an obvious means of preventing dampness. Undoubtedly, natural ventilation exists in most old houses, because of wind-wracking, absence of window caulking and similar causes, which explains why condensation rarely occurs in old houses.

All condensation problems hitherto experienced in buildings may be attributed to a reversal of these conditions. That is, they have developed because the structural materials employed have been such as to create greater resistance to vapor movement on the cold side of the dew-point position than exists on the warm side. All corrective measures center around means of reducing the effectiveness of the cold barrier and increasing vapor resistance on the warm side.

Professor Rowley sums up the whole matter in these words:

"In the past . . . different building materials have been combined without regard to the effect of these combinations on the thermal and vapor properties of a wall. Since the temperatures of the various parts of a wall are controlled by the type and amount of insulation used and the vapor densities in the corresponding parts are controlled by the vapor barriers used, the transmission of heat and vapor through a wall must be considered together, and in most cases an intelligent combination of insulation and vapor barriers will eliminate any chance of trouble. *A fundamental principle often overlooked is that a vapor barrier should be placed on the warm side and not on the cold side of a wall. . . .*

*"The problem is not to be feared after it is once understood."*

#### **Explaining to Clients**

Architects may avoid all technicalities in explaining this new vapor barrier principle by using some parallel situation such as that shown in Figure 1. Here are two basins into which water is running at the same rate. The basin at the left has an outlet larger than the supply. In this no water accumulates. The one on the right has an outlet restricted in size to less than that of the inflow. Here water accumulates until it spills over the sides.

So with the wall sections shown below these basins. The room between is indicated as being warm and humid. In the wall at the left there is a vapor barrier not completely perfect in its stoppage of vapor movement. However, it checks most of the vapor, and what little remains can pass out through the colder side of the wall with little difficulty. This wall shows no accumulation of vapor.

The section at the right of Figure 1 has a similar vapor barrier on the cold side of the air space. Vapor passes freely into this space through the plaster, but cannot move farther so readily. Thus it collects where low outdoor temperatures can condense it into moisture.

If the vapor barrier were perfect in its effect, no vapor would pass through the wall at the left, and no moisture could escape from the wall at the right except by gradual evaporation back into the room, perhaps in the spring or summer. The effect would be the same as shutting off the water at the left-hand faucet, and closing the outlet of the right-hand basin.

#### **Summer Conditions**

It should be pointed out here that in summer there is no need to reverse the location of the vapor barrier, because even with summer air conditioning the indoor temperature rarely or never drops below the dew-point temperature of the outer air. Therefore no condensation can occur.

#### **Vapor Barriers**

Much more knowledge about the vapor resistance of materials is needed than is known at present, for it is apparent that unless a perfect vapor seal is used on the warm side of a wall, the ultimate behavior of that wall is a matter of the *relative* resistance of the materials employed on either side of the dew-point position.

Professor Rowley confined his experiments to a relatively few vapor barriers, but is now proceeding with an extension of the research to explore this field in considerable detail. Teesdale, from both observation and tests, reports on a larger list and is also extending research into this new field. Their observations are condensed herewith.

*Asphalt-impregnated, surface-coated and glazed building paper* weighing 50 lbs. per roll of 500 sq. ft. was found by both Rowley and Teesdale to be completely effective when lapped and tacked to the inner surface of the studs, without attempting to seal the joints with asphalt.

*Laminated sheathing paper* made of two or more sheets of kraft paper cemented together (known as 30-30-30 paper because made of 30 lb. kraft paper with 30 lbs. of asphalt between the layers) was an effective, but not a perfect barrier under the seven test conditions.

*Double-faced reflective insulation*, consisting of aluminum foil cemented to both sides of a kraft paper, was also found to be very resistant to vapor.

*Aluminum paint*, applied in two coats to the interior surface of the plaster, was found to be excellent by both authorities. Teesdale mentions oil paints as less effective barrier materials.

These findings were all drawn from tests intentionally made under severe conditions. It now remains for investigators to determine what lesser barriers may be used with safety under temperatures and weather conditions found more generally in the United States than those extremes used in the tests.

Out of such further research we may confidently expect standards and ratings to guide us in the use of vapor barriers of varying degree of resistance. Technicians of Kimberly-Clark Corporation have already pointed the way in their recommendation "that within the United States vapor seals are needed only in locations north of the Ohio River, and that the seal or barrier used should transmit water vapor no faster than .40 grams per square meter per hour under a vapor pressure of 18 millimeters of mercury."

Absolute protection against occasional condensation in small amounts does not appear to be necessary. Wood with less than 23% moisture content is perfectly safe from dry rot and fungus growth. Moisture penetration producing no greater percentage of moisture than this may not be a fault, but may be beneficial in reducing splitting or shrinkage.

#### **Permeable Materials**

Since the condensation problem may be solved either by a positive vapor stop on the warm side or by having less resistant materials on the cold side than are used on the warm face, it is of much interest to note what these investigators have found about materials commonly employed in construction.

Plaster is an excellent wind stop, being highly resistant to air infiltration even at pressures equivalent to a wind velocity of 15 miles per hr., but vapor will readily pass through it. This passage of vapor may be retarded by paint coatings and certain wall coverings. Other types of wall surfacing materials, such as plywood, fiberboards and plasterboards are also permeable to vapor and here again the surface decorating material has an influence on the total resistance. In the case of plywood the type of glue used is a factor, the phenolic resin glues being much more resistant than soybean and casein glues to the passage of vapor.

It is apparent that wood sheathing and painted siding with ordinary building paper as a wind stop between them is not very resistant to vapor movement, because Professor Rowley found it necessary to introduce a metallic shield in his test sections in order to collect and measure the total amount of vapor reaching the sheathing line. Teesdale notes that "Sheathing paper, when used outside of the sheathing in combination with (inner) moisture barriers should be water-resistant but not very vapor-resistant so that the small amount of water vapor that may leak through the barrier can escape outward. Slaters' felt meets this requirement. Quite possibly this sheathing paper could be omitted entirely; and it is conceivable that the omission would actually result in a drier wall."

#### **Placing the Vapor Barrier**

"Vapor barriers," according to Teesdale, "should be applied vertically on side walls with edges lapping on the studs after the insulation is installed and before

lathing. Horizontal joints should be made only where backed up with a plate or header. The barrier should be brought up tight against electric fixture outlets, air registers, door and window frames and other similar openings. If wood lath, metal lath or other types requiring a plaster key are used, the paper should be applied slightly loose so that the plaster can push the barrier back to form the key. Where ceilings below the attic or roof are insulated, the barrier should be applied in a similar manner."

In this excerpt Teesdale was presumably referring to mineral wool fill insulations, as they were used in his experiments. However, the same principles would apply to vapor barriers used with any insulation installed between the studs, such as blanket and foil curtain insulations and to rigid board insulation employed as sheathing. It might properly be noted that in existing houses, where top-floor ceilings may be insulated with fills applied from above, long after the plaster was installed, it is necessary to place the barrier between the joists against the back of the plaster before installing the insulation.

As in most other details of construction, workmanship has an important bearing on final performance. The most perfect barrier material, poorly installed, will fail to function at high efficiency.

Since neither research project explored the use of rigid boards in relation to vapor barriers and condensation, it is necessary for the time being to draw deductions from the general findings and to assume these deductions are sound until proved otherwise. It has been observed that chronic cases of condensation in walls insulated with rigid boards are rare, and this fact may be attributed to two causes: (1) Rigid insulations are normally quite permeable to vapor and thus permit vapor to pass outwardly without causing accumulation in significant amounts. Even the rigid insulation boards now marketed which are treated with asphalt for maximum weather resistance are probably sufficiently porous to provide adequate means of escape for vapor; (2) The air space within such walls, supplemented by convection currents and slight venting through joints and around framing members, would tend to relieve any dampness condition that might develop temporarily under adverse conditions.

When rigid boards are used as sheathing only, the maximum temperature drop through the wall would tend to occur in the insulation; and vapor pressures, coupled with comparatively free vapor movement, would carry the vapor harmlessly out. A vapor barrier on the warm side of the air space would unquestionably remove any possibility of condensation; but it is not at all certain that a vapor barrier is economically justified, except as an aid in maintaining high indoor humidities.

When rigid insulation is used as a plaster base or interior finish and no other insulation is employed on the cold side, it is probable that the dew-point zone will fall within the insulation near its cold side. Continued vapor movement will apparently carry it on outwardly across the air space and through sheathing, unless some impermeable exterior construction blocks its passage. In this case it is desirable to avoid materials on the cold side of the studs which are resistant to vapor movement.

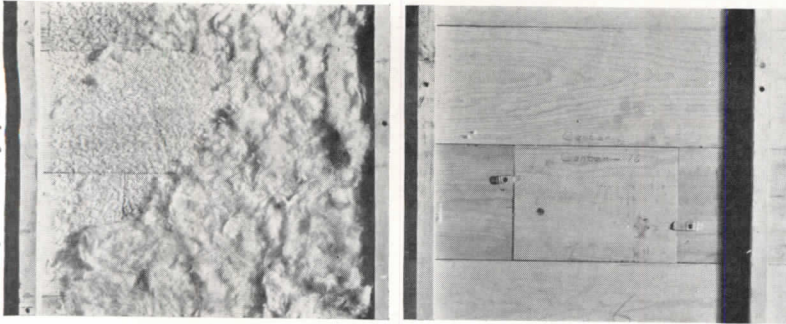

Above left: Severe frost formed during 460-hr. test in panel having no vapor barrier. Mineral wool insulation is shown adhering to the frost on the sheathing. Above right: Very little frost appeared after 460 hours in a similar panel protected by an effective vapor barrier.

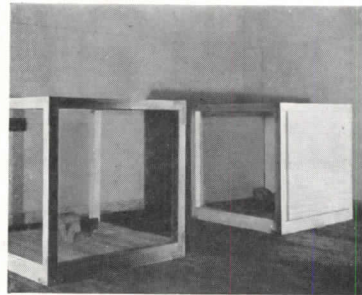
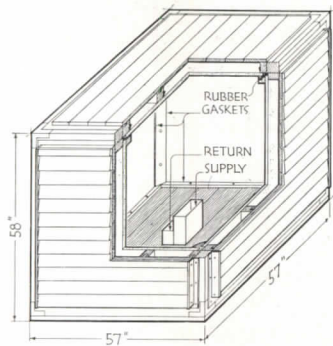

Above right: Frames for the test cubicles used in Professor Rowley's experiments at the University of Minnesota. Note the air supply and return ducts used to maintain uniform inside temperature and humidity. Above left: Cutaway section of test houses showing fixed frames with removable side and ceiling panels. Lower left: Split construction used to facilitate inspection of the interior of the wall and ceiling panels. When the two halves were assembled they represented typical wood frame construction.

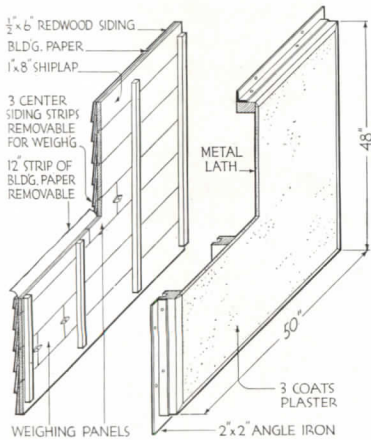

If rigid boards are used on both sides of the studs, as sheathing on the exterior and as a plaster base or interior finish within, the use of a vapor barrier applied to the studs before installing the inner boards would be justified primarily as a means of retaining desired humidity conditions indoors. Ordinarily the permeability of these insulating boards to vapor, coupled with the relatively high temperature in the air space (the latter being particularly significant when thicker insulation is used as sheathing rather than as an interior surfacing) would tend to eliminate the chance of trouble from condensation.

When reflective metal foils are employed, another special set of conditions may prevail which can only be confirmed by tests yet to be made. Independent research by the Aluminum Company of America indicates that foils having a thickness of .0005" are impermeable barriers. Somewhat lighter foils are usually employed on kraft paper, but a substantial volume of experimental evidence obtained in the Aluminum Research Laboratories indicates that paper-backed foil is also quite impermeable to vapor. Any vapor passage observed when such materials are used as barriers may be attributed to leakage at seams and joints that are not made perfectly tight.

Thus foil installations presumably constitute their own vapor barriers if the fitting of the material to the framing members is done as effectively as recommended above for the asphalt-type barrier. But it is conceivable that a single curtain of foil within the air space might have a surface temperature below the dew point and thus develop condensation on its inner surface. Computations indicate that with two (or more) curtains the temperature at the inner curtain is high enough to prevent condensation from occurring there; and thus if

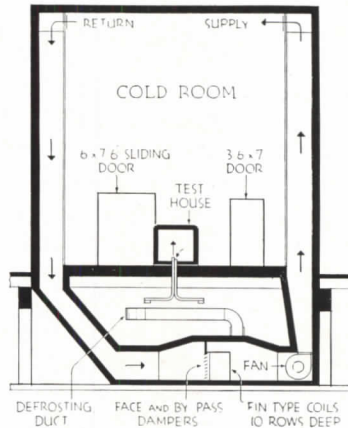

Left: Section through the temperature test room and its cooling apparatus. The room is 30-ft. square and 25-ft. high. Bottom left: The huge low-temperature test room at the University of Minnesota, with test houses in place. Sub-zero temperatures were constantly maintained for protracted periods. Bottom center: Part of the air-conditioning equipment which kept the test room at any desired temperature down to 30°F. below zero. All tests were run at sub-zero temperatures from -7.4°F. to -19.2°F. Bottom right: Air-conditioning equipment which maintained a temperature of 70°F. and a relative humidity of 40 to 46% in the air circulated within the individual test houses. Electrical heaters were used in the ducts.

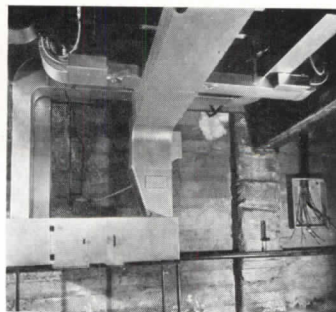
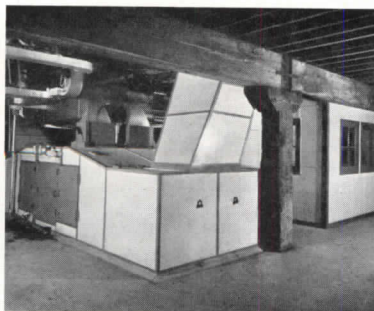
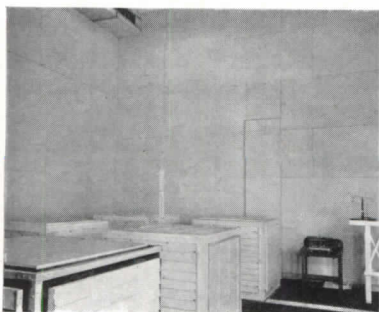



the first curtain were a vapor seal, none would occur elsewhere in the wall. These observations, of course, are based on the assumption that no other vapor barrier intervenes between the foil and the warm air.

Actually most foil installations include a black paper covering across the studs to protect the foil from damage by wet plaster during construction. This paper is probably a partial barrier in itself; it might readily be specified to be of vapor-resistant material to eliminate completely any chance of condensation.

#### **Attic and Roof Insulation**

More evidence of frost and condensation has been reported in attics and under roofs than in side walls, probably because these areas are more visible and any dampness shows quickly on ceilings below. Observers have noted that in all cases condensation has occurred where humid air could be pocketed and exposed to low temperatures.

Principles which apply to wall construction apply with equal force to ceilings, attics and roofs, but somewhat different techniques are needed to meet the conditions encountered. A vapor barrier undoubtedly should be employed on the warm side of any insulation as the first step in minimizing condensation; venting to the cold air is an equally desirable second step. Either one alone may suffice; both are desirable.

Venting of roof areas above insulation may be accomplished by various means, according to the construction involved.

Unoccupied attics or loft spaces, above insulation installed at the ceiling below, should be vented by louvers in gable ends or side walls at the highest possible point, or by ridge ventilators or false chimneys. Wood shingle roofs applied on spaced shingle lath without vapor-resistant papers provide sufficiently free vapor movement to make additional venting unnecessary, but roof decks of any kind which are covered with vapor-resistive materials should have special vents.

Occupied attics or top stories which are insulated at the rafter line or between rafters require ventilators which operate above the insulation, in addition to the highly desirable ventilation of top-floor living spaces in summer to remove accumulations of warm air which cannot otherwise escape. If insulation is carried to the peak of a pitched roof, a ridge ventilator opening into all of the rafter spaces seems to be the only recourse. But more commonly the insulation is carried across the beams below the peak, permitting the use of high gable louvers or a false chimney to ventilate the plenum chamber thus formed.

#### **Corrective Measures**

When an existing structure shows chronic or temporarily serious dampness in walls or roof caused by condensation, it is highly probable that a building paper used on the sheathing or the nature of the exterior construction itself constitutes a vapor barrier considerably more effective than the materials on the warm side. Corrective measures include any practicable means of reducing the resistance of the outer section, increasing the resistance of the inner members, or a combination of both methods.

When the outer sheathing and building paper can readily be reached by removing a strip of siding, it may be sufficient to cut vapor passages into the studding space by one of several methods: (1) If a heavy sheathing paper seems to form the barrier, it may be cut along the horizontal joints of sheathing boards near the base and top of the stud spaces, or a narrow strip removed. The siding can be restored over this "breather" line. (2) If tight, solid sheathing is judged to constitute the barrier, holes may be bored through it (after removing the siding as before) to form breather holes for vapor movement. (3) If the insulation was originally blown in as a fill from the outside, the holes cut for the pneumatic hose may be uncovered and left open, except as they are protected by the restored siding.

It may be noted that several large organizations installing fill insulations by the pneumatic process have left these blowholes open as standard practice over a period of several years, and have had no reports of dampness in walls vented by this simple method.

When it is impracticable to break the outer vapor barrier by some such means, an alternative is to paint the interior faces of walls and ceilings containing insulation with two coats of aluminum paint, or any other vapor-resistant coating which subsequent research may prove effective. These surfaces may then be redecorated as desired.

Corrective steps to be taken in attics or roof structures include the following alternative methods: (1) Loose fill or batt-form insulation, that has been placed between ceiling joists and is readily accessible, may be lifted and replaced after inserting a vapor-resistant paper against the plaster, tacked tightly against the wood members. (2) Insulation installed between rafters may be covered with a vapor-resistant membrane. (3) Ventilation of the spaces above the insulation should be provided by any of the means suggested as effective for new construction.

In consequence of these simple methods of preventing, alleviating, or correcting dampness caused by condensation, it may be truly said "the problem is not to be feared once it is understood."

#### **Application Principles**

The accompanying Time-Saver Standards sheet (Serial No. 102) presents in graphic form an interpretation of the *theory* of vapor barrier protection against condensation within walls and roofs. It should be noted that, with the exception of mineral fill insulations and certain blanket insulations, no actual tests have been made to measure the need for vapor protection nor to confirm the application of the theories developed from the research reported here. In each instance the drawing idealizes the use of a barrier and shows its best location of maximum effectiveness and practicability.

Manufacturers will more or less rapidly develop recommended techniques in the use of their individual products, which should be followed in architect's specifications. Standard recommendations of this nature have already been issued by the National Rock and Slag Wool Association which financed the research at the University of Minnesota. Others will undoubtedly appear as the need becomes apparent.

**MARCH 1938      How to Find HEAT TRANSMISSION of Building Sections**

**PURPOSE**

This sheet supersedes the original edition (T-S.S. M1.1.1, Serial No. 64, November, 1936) of like title. It contains revised data based on Chapter V of the American Society of Heating and Ventilating Engineers' Guide, 1938.

The determination of heating and cooling loads in buildings is governed in large measure by the heat transmission of the enclosing walls, roofs, floors and other exposed parts of buildings. The "coefficient of thermal transmission" designated by the symbol *U*, which expresses the rate of heat transmission, is given for a number of typical building sections in T-S.S. M1.1.2, "Heat Transmission through Building Sections with Per Cent of Heat Transfer Stopped by Insulation." Values for other commonly employed building sections are published in the current ASHVE Guide. When any building section differs in its assembly of component materials from those published in these or similar sources it is necessary to calculate the over-all coefficient of heat transmission *U*. The method of making such computations and the basic data required are presented in this sheet.

**THEORY UNDERLYING CALCULATIONS**

The over-all coefficient of heat transmission *U* is the amount of heat expressed in Btu transmitted in one hour per square foot of wall, floor, roof or ceiling for a difference in temperature of 1 degree F between the air on the inside and that on the outside of the building section.

It has been determined that heat transfer is retarded by the following elements comprising a wall, roof or other building section, taken in order from outside air to inside air: (1) the resistance of a film of air on the outside (which is generally considered to be exposed to wind velocities averaging 15 miles per hour); (2) the resistance of each layer of building materials forming the structural section; (3) the resistance of each measurable enclosed air space formed within the building section; and (4) the resistance of the surface film of air on the inner face (which is considered to be in still air).

The over-all coefficient of heat transmission *U* is the reciprocal of the sum of the foregoing resistances.

**THICKNESS OF MATERIALS**

When a material is homogeneous, such as a piece of wood or insulating board, its ability to transfer heat is measured and expressed "per inch of thickness." Its thermal conductivity (*k*) is the Btu transmitted per hour, per square foot, per degree F difference in temperature between the two faces, per inch of thickness. Its internal resistivity is the reciprocal ( $1/k$ ) of its thermal conductivity. When calculating over-all coefficients of heat transmission *U* of building sections it is necessary to take thickness into consideration. Example: Assume a material having a conductivity of .33 and therefore a resistivity of  $1/33$  or 3.03 is to be used in a thickness of  $\frac{3}{4}$  inch. In the calculation of its contribution to the resistance of the whole section it is necessary to divide its conductivity by  $\frac{3}{4}$ " ( $.33 \div .75 = .44$ ) or to multiply its resistivity by  $\frac{3}{4}$ " ( $3.03 \times .75 = 2.27$ ) which is also the reciprocal of .44. It is easy to remember these relationships by the fact that a low conductivity (*k*) indicates superior insulation value while a low resistivity ( $1/k$ ) indicates poor insulation value.

When a material is not homogeneous, such as a hollow building block or a composite of plaster and lath, laboratory tests are made for each thickness of material commonly used rather than per inch of thickness. The values are then stated thus: thermal conductance (*C*) is the Btu transmitted per hour, per square foot, per degree F difference in temperature between the two faces, for the thickness stated or used in construction. Internal resistance (*R*) is the reciprocal of thermal conductance (that is,  $R = 1/C$ ).

If the thermal conductivity or thermal conductance of a material is known, its resistivity or resistance (as the case may be) can be found by taking the reciprocal of the known value.

**REQUIRED DATA**

The accompanying table gives the values for common building and insulating materials recommended for use in computing heat transmission coefficients by the ASHVE Guide, 1938. It shows the conductivity (*k*) or conductance (*C*) and the resistivity ( $1/k$ ) or the resistance (*R*). Values for a variety of proprietary products and for variations from average

types of staple building materials may be found in the ASHVE Guide, 1938, beginning on page 97. For all normal computations the data presented here should be used.

**PROCEDURE**

To compute the correct over-all coefficient of transmission *U* for any wall, floor, ceiling or roof section for which the coefficient cannot be found in existing tabular data (except when reflective insulations are involved) proceed as follows:

**Rule I.** Find in the accompanying table the resistance (*R*) or the resistivity ( $1/k$ ) of each material, exposed surface and air space in the given section. Where resistivities are given (per inch of thickness) adjust the value to the actual thickness used by multiplying the resistivity by the actual thickness in inches or decimals thereof. Take the sum of all resistances and divide into one (to obtain the reciprocal of the sum); the result is the coefficient of transmission *U* in Btu per square foot per hour per degree F.

Example 1: To compute the over-all conductivity *U* of a typical frame wall comprising the materials listed:

Exterior surface resistance (15 mph. wind movement).....	.17
Fir sheathing, building paper, Y. P. lap siding.....	2.00
Air space between studs.....	.91
Metal lath and plaster, $\frac{3}{4}$ ".....	.23
Interior surface resistance—still air.....	.61
<b>Over-all Resistance</b> .....	<b>3.92</b>

Over-all coefficient of transmission  $U = 1/3.92 = .26$  Btu per square foot per hour per degree F.

Example 2: To find the effect of using one inch of rigid insulating board in place of wood sheathing and the introduction of one inch blanket form insulation midway in the air space in the same wall:

Exterior surface resistance (15 mph.).....	.17
Fir siding (shingles or clapboards).....	.78
1" rigid insulating board sheathing.....	3.03
First air space .....	.91
1" blanket insulation .....	3.70
Second air space .....	.91
Metal lath and plaster.....	.23
Interior surface resistance—still air.....	.61
<b>Over-all Resistance</b> .....	<b>10.34</b>

Over-all coefficient of transmission  $U = 1/10.34 = .10$  Btu per square foot per hour per degree F.

**Reflective metals** used as insulation must be associated with air spaces. The metal may be installed on one or both sides of an air space or as curtains dividing the air space into two or more separate air spaces. Thus in some cases an air space may have one side faced with aluminum foil and in other cases both sides may be bounded by foil. Values for each condition and for two widths of air spaces are given in the accompanying table.

**Rule II.** To find the over-all coefficient of transmission of any construction involving reflective metals, follow Rule 1, substituting for the normal air space resistance (.91) the resistance of each air space bounded on one or both faces by bright metal as given in the accompanying table. Note that this table also includes values for standard assemblies of foils which save the addition of the separate air spaces.

Example 3: To find the effect of adding to the wall section defined in Example 1 an aluminum-faced plaster base and two equally spaced curtains of foil within the air space:

Exterior surface resistance (15 mph.).....	.17
Fir sheathing, building paper, Y. P. lap siding.....	2.00
First air space (bounded 1 side by foil) over .75".....	2.17
Second air space (bounded both sides by foil) over .75".....	2.44
Third air space (bounded both sides by foil, one being the curtain and the other the plaster base) over .75".....	2.44
Metal lath and plaster.....	.23
Interior surface resistance—still air.....	.61
<b>Over-all Resistance</b> .....	<b>10.06</b>

Over-all coefficient of transmission  $U = 1/10.06 = .10$  Btu per square foot per hour per degree F.

# How to Find HEAT TRANSMISSION of Building Sections

MARCH 1938

## PER CENT OF HEAT TRANSFER STOPPED

It is sometimes convenient to express the values resulting from the use of an insulation material in nontechnical terms, particularly when dealing with clients. This may be expressed as "per cent of heat transfer stopped by the use of building insulation materials." This percentage may be found by using the formula given on T-S.S. M1.1.2 or as follows:

**Rule III.** Determine the coefficient of transmission of the building section as it would be constructed without using an insula-

tion material. Also compute the coefficient of transmission of the same section as if the selected insulation materials had been incorporated therein. Subtract coefficient of transmission of the insulated section from the coefficient of transmission of the uninsulated section and divide this difference by the coefficient of transmission of the uninsulated section. Multiply by 100 to obtain per cent of heat transfer stopped by the use of insulation.

## RECOMMENDED VALUES FOR COMPUTING OVERALL COEFFICIENTS OF HEAT TRANSMISSION

MATERIAL	Conductivity or Conductance*	Resistivity or Resistance*	MATERIAL	Conductivity or Conductance*	Resistivity or Resistance*
<b>MASONRY MATERIALS</b>			<b>ROOFING CONSTRUCTIONS—(Cont.)</b>		
Brick—Low density	5.00	.20	Shingles	6.00*	.17*
—High density	9.20	.11	Asbestos	6.50*	.15*
Brickwork—Damp or wet	5.00	.20	Asphalt	10.37	.10
Cement Mortar	12.00	.08	Slate	1.28*	.78*
Cement Block (8 inch)—(See Note a)—			Wood		
—Sand and gravel aggregate	1.00*	1.00*			
—Crushed limestone aggregate	.856*	1.17*	<b>PLASTERING MATERIALS</b>		
—Cinder aggregate	.60*	1.66*	Plaster (Gypsum)	3.30	.30
—Haydite aggregate	.495*	2.02*	Metal Lath and Plaster (3/4")	4.40*	.23*
Cement Block (12 inch)—(See Note a)—			Wood Lath and Plaster (3/4")	2.50*	.40*
—Sand and gravel aggregate	.80*	.....	Plaster Board—3/8 inch	3.73*	.27*
—Cinder aggregate	.531*	1.88*	—1/2 inch	2.82*	.35*
—Haydite aggregate	.468*	2.13*	<b>INSULATING MATERIALS</b>		
Concrete—Sand and gravel	12.62	.....	Blanket or Flexible Fiber	.27	3.70
—Limestone	10.83	.....	Loose fill or bat type:		
—Cinder	4.86	.....	Gypsum (flaked, dry and fluffy)	.48	2.08
—Haydite	3.96	.....	Mineral Wool, all forms	.27	3.70
Stone	12.50	.08	Rock Wool, Glass Wool	.27	3.70
Stucco	12.00	.08	Rigid,		
Tile—Structural Clay— 4 inch	1.00*	1.00*	Corkboard	.30	3.33
6 inch	.64*	1.57*	Fiber, typical wood, cane, etc.	.33	3.03
8 inch	.60*	1.67*	Reflective Type (see below, Air Spaces faced with reflective metals—aluminum foil)		
10 inch (See Note b)	.58*	1.72*			
12 inch	.40*	2.50*	<b>AIR SPACE AND SURFACE COEFFICIENTS</b>		
16 inch	.31*	3.23*	Air Spaces, over 3/4" faced with ordinary building materials	1.10*	.91*
Tile—Hollow Gypsum—4 inch	.46*	2.18*	Surfaces, Ordinary—Still air	1.65*	.61*
Tile or Terrazzo Flooring	12.00	.08	—Air in motion, 15 mph	6.00*	.17*
			Surface, Rough Stucco, Air in motion, 15 mph	9.00*	.11*
<b>BUILDING CONSTRUCTIONS</b>			<b>AIR SPACES FACED WITH REFLECTIVE METALS (ALUMINUM FOIL)</b>		
Frame			Air space, faced one side with foil: over 3/4" wide	.46*	2.17*
Fir Sheathing (1"), Building Paper	.71*	1.41*	Air space, faced one side with foil: 3/8" wide	.62*	1.61*
Fir Sheathing (1"), Building Paper and Yellow Pine Lap Siding	.50*	2.00*	Air space, faced both sides with foil: over 3/4" wide	.41*	2.44*
Fir Sheathing (1"), Building Paper and Stucco	.55*	1.82*	Air space, faced both sides with foil: 3/8" wide	.57*	1.75*
Pine Lap Siding and B'ld'g Paper, Siding 4" wide	.85*	1.18*	Air space divided in two with single curtain of foil (both sides bright). Each space over 3/4" wide	.23*	4.35*
Yellow Pine Lap Siding	1.28*	.78*	Each space 3/8" wide	.31*	3.23*
Flooring			Air space with multiple curtains of foil (bright both sides) curtains more than 3/4" apart, in standard construction, air circulation prevented:		
Battleship Linoleum (1/4")	1.36*	.74*	2 curtains forming 3 spaces	.15*	6.78*
Woods (Across Grain)			3 curtains forming 4 spaces	.11*	9.22*
Maple or Oak (typical hardwoods)	1.15	.87	4 curtains forming 5 spaces	.09*	11.66*
Yellow Pine or Fir (typical softwoods)	.80	1.25			
<b>ROOFING CONSTRUCTIONS</b>					
Roofing					
Asphalt, composition or prepared	6.50*	.15*			
Built-up—3/8 inch thick	3.53*	.28*			

### NOTES

\* Indicates conductances and resistances for the thickness stated or used in construction, not per 1 inch thickness. All values not so marked are conductivities or resistivities and must be proportionately modified if the material is used in any other net thickness than 1 inch

- (a) One air cell in direction of heat flow
- (b) Structural clay tile values for 6", 8" and 10" units are based on

two air cells in the direction of heat flow. The 12" tile is based on three cells in the direction of heat flow. The 16" hollow tile consists of one 10" and one 6" tile, each having two cells in direction of heat flow

All values are taken from A.S.H.V.E. Guide 1938, Chapter 5, Table 2, "Conductivities and Conductances of Building Materials and Insulators" and are those recommended for computing heat transmission coefficient

**PREVENTING CONDENSATION IN INSULATED STRUCTURES**

Methods shown here of preventing condensation in insulated structures are based on research conducted by L. V. Teesdale, senior engineer, Forest Products Laboratory, Madison, Wisconsin, (published late in 1937 as a U. S. Forest Products Laboratory report) and by Prof. F. B. Rowley, A. B. Alfren and C. E. Lund of the Engineering Experiment Station, University of Minnesota (presented as a paper before the ASHVE January 25, 1938).

**PRINCIPLES**

These research authorities, working independently, arrived at practically identical conclusions. Their findings coincide with field experience and much independent research data and may therefore be considered basic. Three methods of preventing, alleviating or correcting dampness caused by condensation in walls, roofs and cold floors of heated buildings were indicated: 1. A barrier of any material that is completely or highly resistant to the passage of water vapor, properly installed in the

warm (interior) side of the construction where it will remain above the dew-point temperature within the section, will prevent condensation by keeping out the moisture that otherwise might be precipitated.

2. Use of materials on the warm side of the construction, which have a greater total resistance to the passage of water vapor than that of all the materials used on the cold side of the dew-point temperature region, will prevent or eliminate condensation by allowing the natural forces of vapor pressure to move whatever vapor penetrates from the warm side on through to the cold exterior air.

3. Ventilation of the cold side of the dew-point region to the outer air will prevent or eliminate condensation as in the preceding method by allowing whatever vapor penetrates from the warm side to escape freely to the cold exterior air.

In other words, a vapor barrier should be used on the warm side and not on the cold side of a wall, roof or floor; and whenever construction requirements create greater resistance to vapor movement on the cold side than exists on the warm side, the cold side should be vented to the outer air.

**BLANKET**

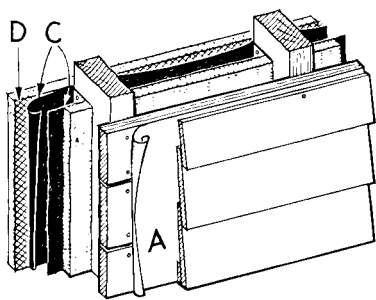

**FLEXIBLE BLANKETS:** Sheathing paper A should be porous to vapor. A highly resistant vapor barrier C should be provided on the warm side, either as an integral part of the blanket insulation or as a separate element. Blanket insulation may divide air space as shown or may be placed against sheathing or adjacent to the vapor shield.

**FILL**

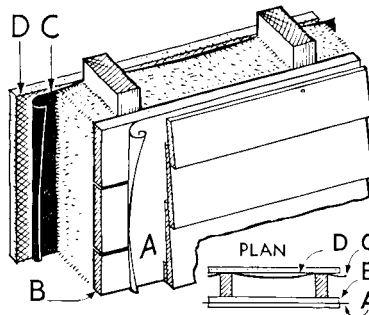

**CONDITION 1. NEW CONSTRUCTION:** Insulation applied from interior. Sheathing paper A should be porous to vapor. Install insulation between studs and cover with barrier C of paper highly resistant to vapor. Allow paper enough slack (see plan) to permit plaster to key properly to any open plaster base D.

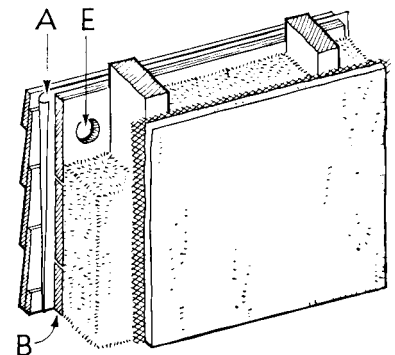

**CONDITION 2. OLD WORK:** Insulation blown in from outside. After filling spaces between framing members by pneumatic process, leave hose holes E uncovered except by siding, or cover with paper that is porous to vapor. This is particularly desirable if existing sheathing paper A is an effective vapor barrier.

**RIGID BOARD**

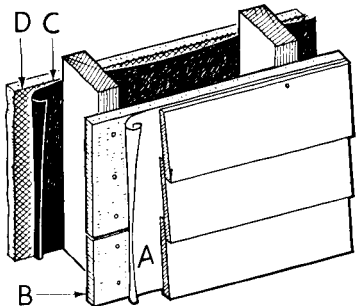

**CONDITION 1. SHEATHING ONLY:** Sheathing paper A seldom required, but if used should be porous to vapor. Insulation sheathing B of any required thickness. Preferably install vapor barrier C on inside face of studs, using highly vapor resistant material. Allow slack for plaster keys if lath D is open type.

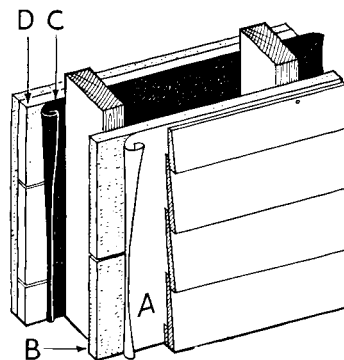

**CONDITION 2. SHEATHING AND PLASTER BASE:** Sheathing paper A seldom required, but if used should be porous to vapor. Insulation sheathing B preferably of greater thickness than insulating plaster base D. Vapor barrier C on inside of studs beneath plaster base desirable but not essential.

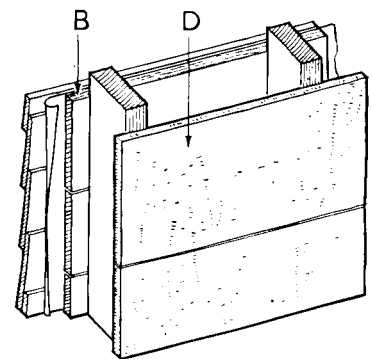

**CONDITION 3. INTERIOR FINISH ONLY:** When exterior sheathing B is wood and insulation board D serves as an interior finish of decorative texture or color, no vapor barrier is necessary. Experience indicates that air space between studs and normal leakage removes condensation safely.

# PREVENTING CONDENSATION IN INSULATED STRUCTURES

## LIMITATIONS

Both research authorities based their studies on mineral wool fill insulations under relatively severe conditions of long duration. The preventive and corrective methods here indicated for fill insulations are known to be effective and are approved by the National Rock and Slag Wool Manufacturers Association. The application of the same principles to other forms of insulation are made by deduction and not all have yet been confirmed by tests. These recommendations, however, have been approved by ten acknowledged authorities and may be followed until further research indicates otherwise.

Consult manufacturers of the type of insulation to be employed for specific recommendations regarding the use of vapor-resistant barriers or venting methods (if any are needed) in conjunction with their products.

## METHODS OF CORRECTING CHRONIC DAMPNESS CONDITIONS IN EXISTING WORK

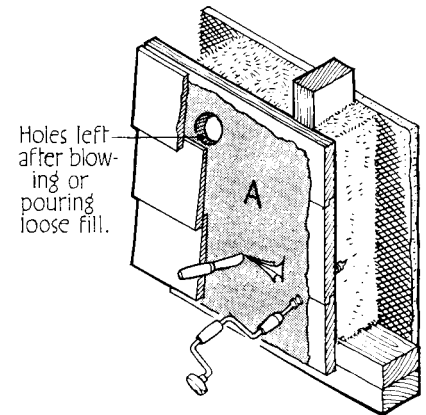

If necessary, puncture existing vapor seal by cutting along sheathing joints or by drilling breather holes.

### ANY INSULATION IN ANY CONSTRUCTION WHICH SHOWS DAMPNESS CAUSED BY CONDENSATION:

Chronic dampness in existing walls or roofs, whether or not insulated and without respect to the type of insulation that may have been employed, may usually be attributed to the existence of a vapor barrier A which is more resistant to the passage of vapor than construction materials on the warm side. Puncture this barrier by any practical means, such as uncovering blowing holes that may have been sealed after installing fill insulation, by cutting the paper along one or more sheathing joints, or by shielded breather holes bored as indicated. If, after reasonable trial, these steps are not entirely effective, apply vapor seal on plaster surface, using two coats of aluminum paint or other tested coating material, and redecorate.

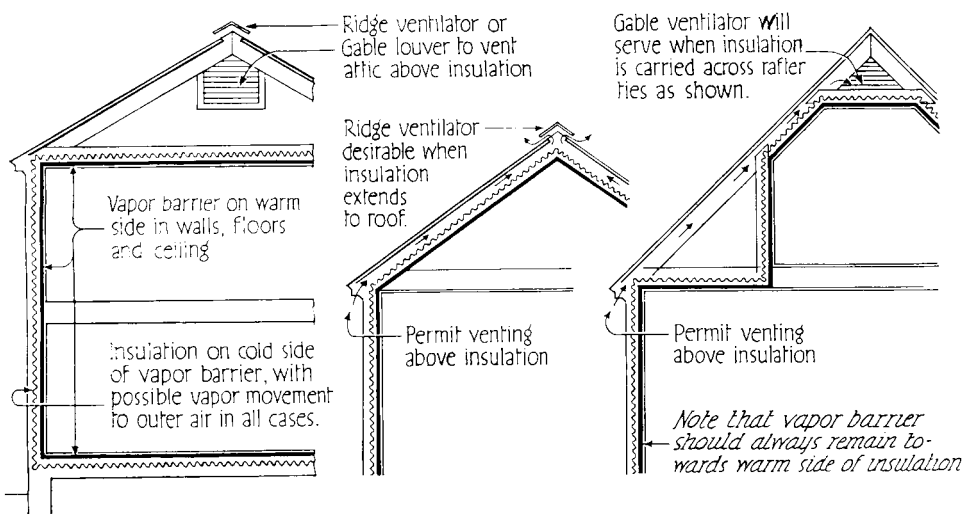

## DEMONSTRATING THE VENTING OF ROOFS ABOVE INSULATION PROTECTED BY A VAPOR BARRIER

### REFLECTIVE

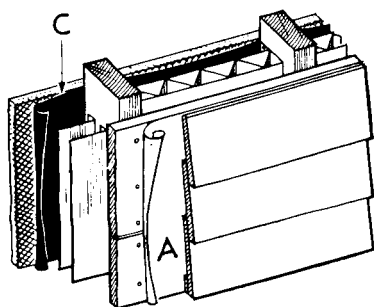

**CONDITION 1. SINGLE OR MULTIPLE CURTAINS:** Sheathing paper A should be porous to vapor. Foil curtains, properly installed, function largely as vapor barriers in themselves, hence vapor resistant paper C is optional but desirable as extra protection. Black paper often used to protect foils from fresh plaster may be specified as vapor resistant grade.

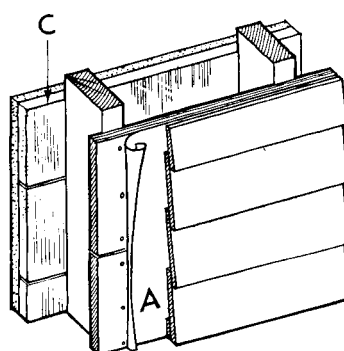

**CONDITION 2. FOIL ON PLASTER BASE:** When foil or other reflective material is an integral part of the plaster base or interior finish, with the reflective surface facing the air space, it must function as a vapor barrier also. Do not apply paper or other barrier in contact with any reflective insulation as its thermal effectiveness is destroyed unless it faces an air space.

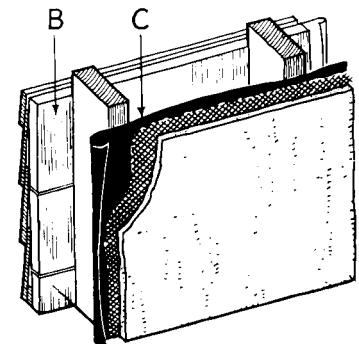

**CONDITION 3. FOIL ON SHEATHING:** When foil or other reflective material is an integral part of the exterior sheathing B, with the reflective surface facing the air space, a barrier C highly resistant to vapor should be used under the plaster base and plaster whenever possible. Also, vapor movement through the sheathing should be permitted at the joints or otherwise.

# Building Volume and Cost Trends

By **CLYDE SHUTE**, Manager, Statistical & Research Division, F. W. Dodge Corporation

## Method for Use of Charts

AN APPROXIMATION to accuracy of construction cost data on materials and labor combined can only be obtained by determination of cost trends.

The base data for the charts displayed on these two pages have been secured from E. H. Boeckh & Associates, Incorporated.

The United States average for each type of construction for 1926-1929 is used as the base period, or 100, because prices of both labor and materials showed greatest stability during these years.

Six general construction types will be presented, at the rate of two per month, because the quantities of the different building materials and the amounts of the different classes of labor vary in each type of building. The

six types\* to be shown will appear in the following order: (1) Brick, (2) Steel, (3) Frame, (4) Brick and Wood, (5) Brick and Concrete, and (6) Brick and Steel.

Sixteen representative but widely scattered cities will be shown monthly for each type displayed because material prices and labor rates are different in the various localities and do not change at the same time in all cities, nor to the same degree.

The index numbers indicate the relationship of the current or reproduction cost of a building at any given time, in any given place, to the 1926-1929 United States average cost for an identical building.

The plotting of the data provides readers with a quick and efficient method of construction cost comparisons.

\*These six types were presented in December, 1937, pp. 75-77; January, 1938, pp. 65-67; and February, 1938, pp. 82, 83.

## CONSTRUCTION COST INDEX

## Brick Buildings

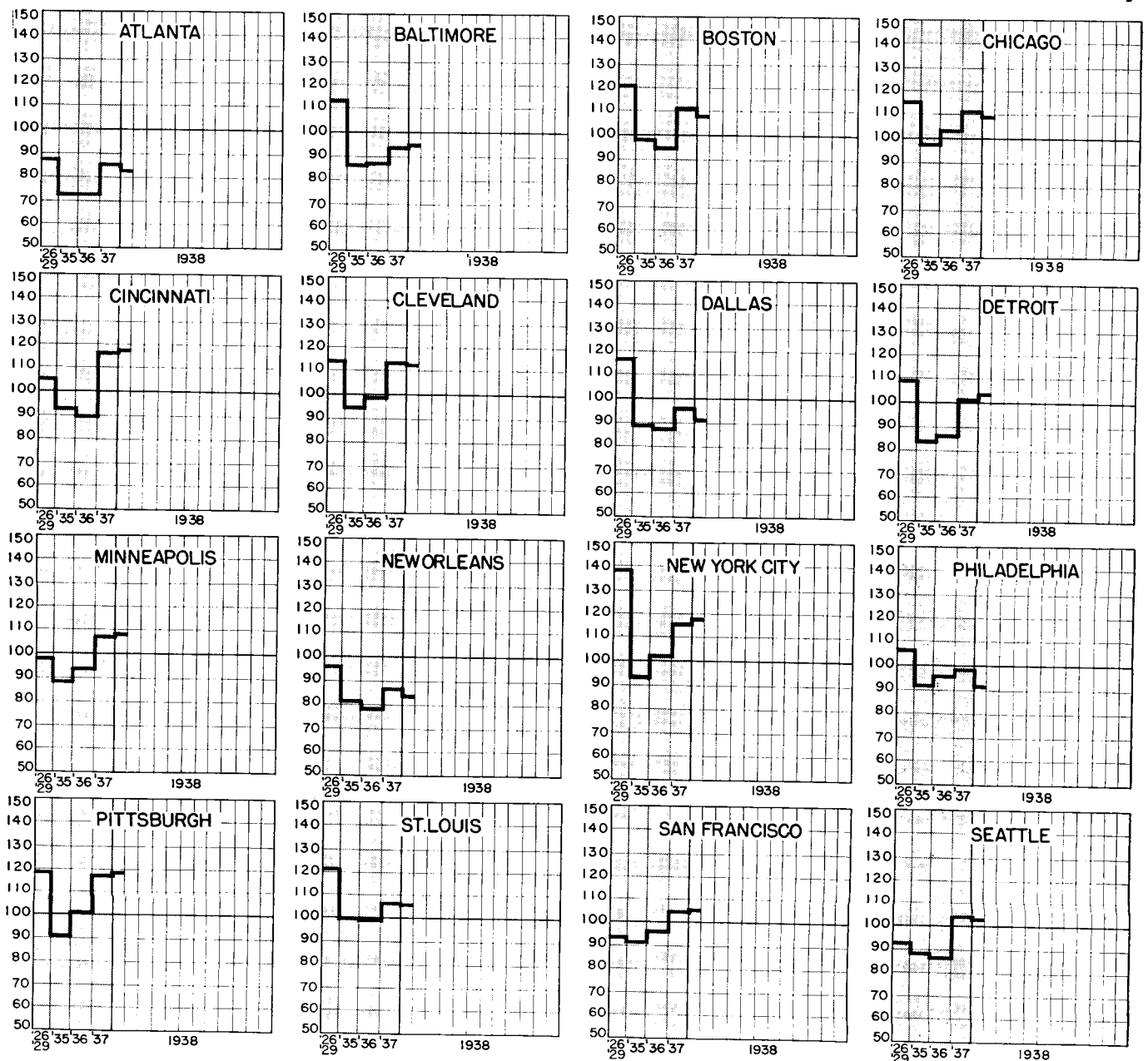

### TOTAL BUILDING—37 EASTERN STATES\*

Planned by Architects or Engineers and by Others

CLASSIFICATION	ARCHITECT-ENGINEER PLANNED		PLANNED BY OTHERS		Thous. Dollars
	Thous. Dollars	%	Thous. Dollars	%	
One & Two Family Houses	308,947	43	372,489	55	681,436
All Other Building	1,169,657	85	202,372	15	1,372,029
Commercial	185,278	62	111,765	38	297,043
Industrial	313,688	100	.....	..	313,688
Educational	215,420	93	15,287	7	230,707
Hospitals & Institutions	73,344	90	8,502	10	81,846
Public Buildings	90,854	87	14,017	13	104,901
Religious & Memorial	30,069	82	6,799	18	36,868
Social & Recreational	62,905	76	20,214	24	83,119
Apartments & Hotels	198,099	89	25,758	11	223,857
<b>TOTAL BUILDING</b>	<b>1,478,604</b>	<b>72</b>	<b>574,861</b>	<b>28</b>	<b>2,053,465</b>

\*12 months, 1937.

### TOTAL BUILDING\*

Architect-Engineer Planned vs. Others

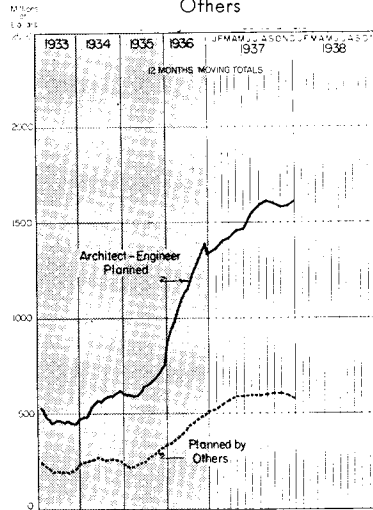

\*37 Eastern States

### EDUCATIONAL BUILDING\*

Architect Planned vs. Others

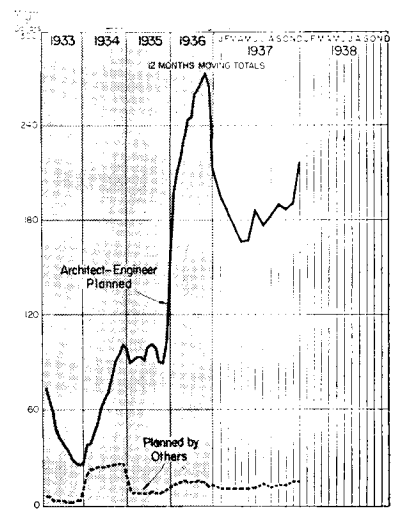

\*37 Eastern States

### CONSTRUCTION COST INDEX

### Steel Buildings

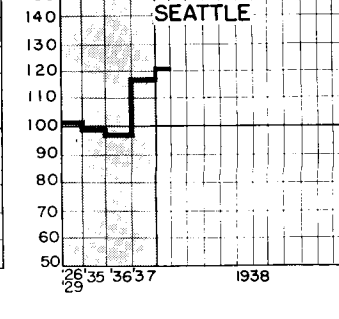
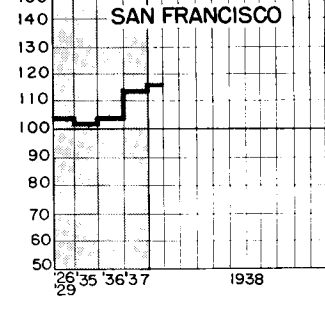
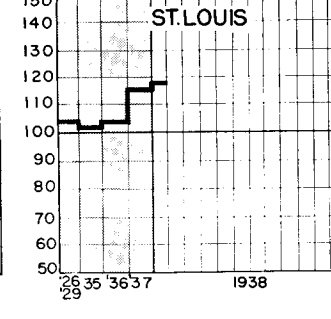
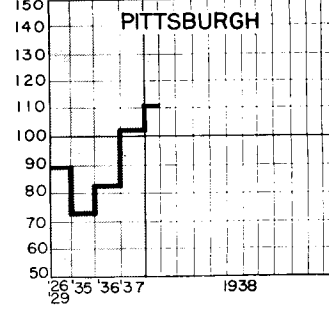
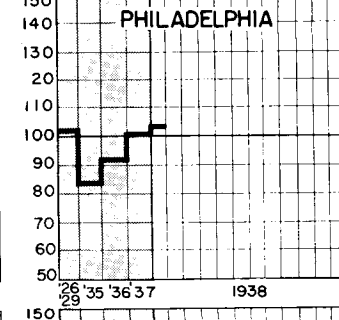
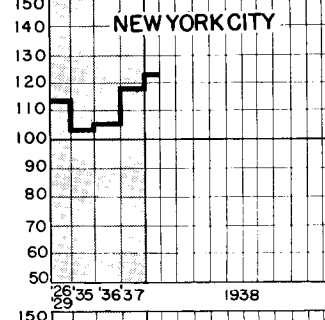
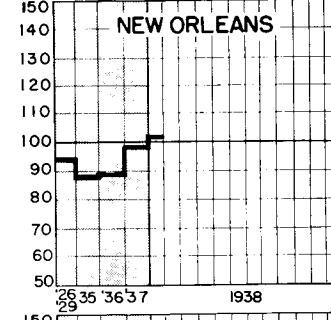
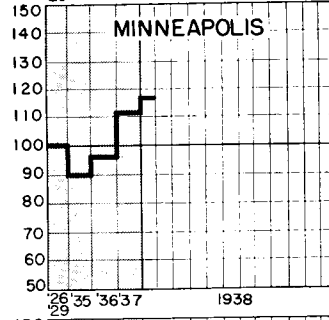
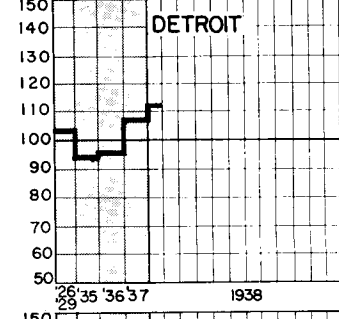
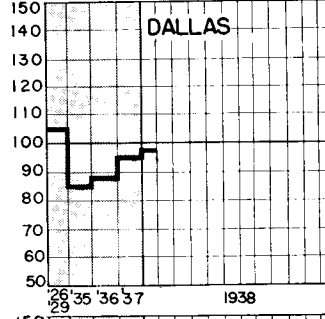
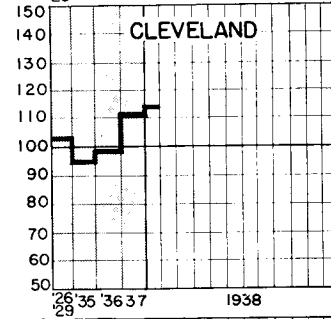
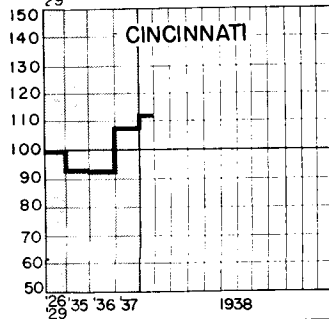
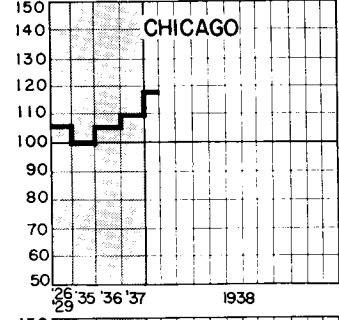
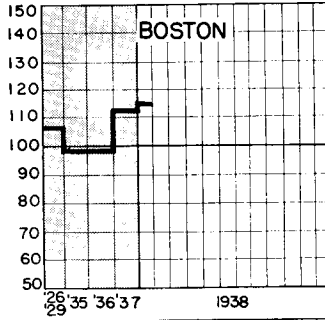
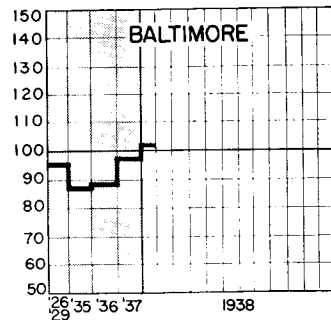
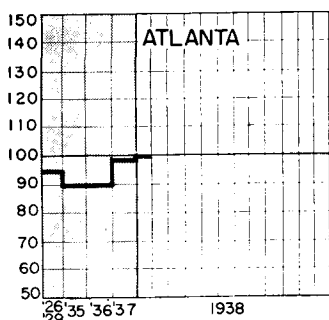

# Reviews of New Books

**GLASS IN ARCHITECTURE AND DECORATION.** By Raymond McGrath and A. C. Frost. With a section on the nature and properties of glass by H. E. Beckett of the Building Research Station. Published by The Architectural Press, London. Handled in U. S. A. by Architectural Record. Price, \$20.

CORBUSIER has shrewdly said that the history of architecture is the history of the struggle for the window. Architecturally, glass has been arriving for two thousand years; yet this is the age of glass.

The development of the window from the light aperture to the *pan de verre* has not been a purely structural matter. As the complement of the structural part of a building, glass has at one time, by the inadequacy of its manufacture, retarded the development and at another, by the improvement in its manufacture, been better able to cope with the development than structural considerations permitted. Throughout its progress from mystery to science, glass-making has had an intimate bearing on architecture, and particularly is this so now since synthetic materials have enormously increased the importance of the manufacturer and the technologist. By their initiative they have not only widened the architectural applications of glass but have refined its properties and so increased its usefulness and its range of indispensability.

The section on "The Properties of Glass" by H. E. Beckett of the British Building Research Station and the sub-section included under the title "The Transmission and Reflection of Sound by Glass" by C. J. Morreau, also of the Research Station, are valuable contributions to the literature of glass.

Section 1 is on the making of glass from its Syrian origin onward. Chemistry and the crafts shaped its uses until the 19th century when light absorption glasses emerged, followed by rapid developments which include tempered or toughened glass, laminated glass, heat-absorptive glass and glass construction units.

In the valuable section on the nature and properties of glass, the authors consider: the durability and cleaning of glass, mechanical strength, hardness, transmission of heat through glass, glass in natural and artificial lighting, ultraviolet transmission properties, transmission and reflection of sound by glass, and some special properties of glass-and-concrete and glass-brick construction.

A monumental work of reference for architects, engineers, technologists, builders and all students of design. The book size is 9½" x 12½". There are 650 pages; 462 halftone and line illustrations.

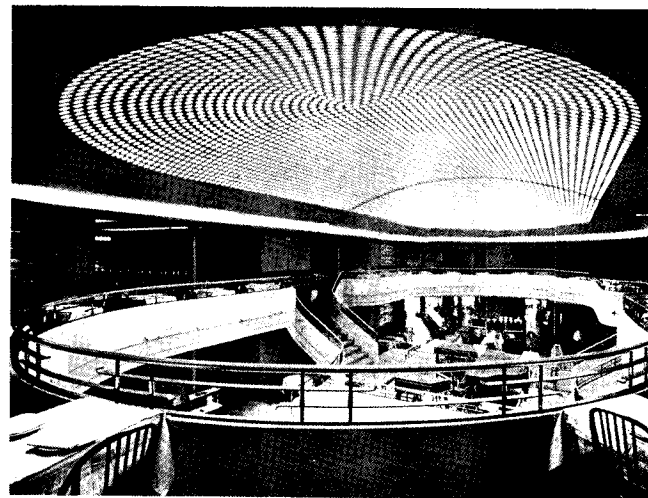

From "Glass In Architecture and Decoration"

**A.S.T.M. STANDARDS ON CEMENT.** Published by American Society for Testing Materials, Philadelphia. 1937. Price, \$1.

THIS publication is intended primarily to present in convenient form the various ASTM standards and tentative standard specifications, methods of chemical analysis, and methods of physical tests pertaining to cement. There is also included the Manual of Cement Testing.

**MUNICIPAL AND COUNTY PARKS IN THE UNITED STATES.** Prepared under the direction of George D. Butler. U. S. Government Printing Office, Washington. 1937.

THE NATIONAL PARK SERVICE in cooperation with the National Recreation Association made this study of municipal and county parks in the United States in the year 1935. It shows the status of the municipal and county park movement in that year but also affords a basis for studying the development of the movement during the preceding decade.

**CONTEMPORARY ART APPLIED TO THE STORE AND ITS DISPLAY.** By Frederick J. Kiesler. Brentano's, Louis Scall, 5 Minetta Lane, New York City. Price, \$2.50.

THIS BOOK was written, says the author, because the country has been flooded with examples of poor and distorted modernism; because the sudden influence of contemporary art makes it necessary to control its real value; because the new beauty must be based on efficiency and not on decorative cosmetics; because the established store is facing the problem of changing its front, its windows, or both, and probably its interior, too.

The volume is not confined to stores and display but includes opening chapters on architecture, sculpture, painting and the fine arts as the basis of decoration.

**HOUSES (\$7,500 and under)—**

A reference study in the BUILDING TYPES section—starts on page 133



Only a  
**BEAUTIFUL  
 METAL** *would suit  
 this salon of  
 Beautiful Cars*



This unusual photograph was taken from the second floor of the Chrysler salon in New York. It shows part of the main floor, resplendent with gleaming cars. The soft highlights reflected from the balustrades of the Westinghouse electric stairway give some idea of the fluent beauty of the metal selected for the decorative trim of this thoroughly up-to-date escalator.

The architects, Reinhard & Hofmeister, desired a material possessing lightness of tone to harmonize with the modern design of these attractive show rooms. They selected Solid Nickel Silver because it offered a

rich pastel shade bordering on white that blended perfectly with the general decorative scheme.

The soft, lustrous sheen of Solid Nickel Silver makes it one of the handsomest metals for ornamentation—its warm, glowing highlights giving equally happy results with all the commonly used building materials, marble, stone, tile, wood, etc.

Moreover, Solid Nickel Silver is extremely durable, possesses adequate structural strength, meets all fabricating requirements and is readily available through the usual sources of supply.

*Photo by S. F. Lincoln of New York City*



*Solid* **NICKEL** *Silver*

THE INTERNATIONAL NICKEL COMPANY, INC., 67 WALL STREET, NEW YORK, N. Y.



The house pictured in upper corner was built in 1907 and remodeled in 1928.



# CEDAR SHINGLES

*Offer*

## the Best Solution for REMODELING

*... at Minimum Cost*

THE HISTORY of this house is common to that of many built of similar design in rapidly growing cities during the period about twenty-five to thirty years ago. In remodeling, the architect very deftly used Cedar Shingles with wide weather exposure over the old walls, over-roofed with No. 1 Cedar Shingles and landscaped the garden. The

result is a charming, livable home created at a minimum cost with Cedar Shingles. One of the surprising results was the astonishing amount of added insulation . . . attributable to the high insulation qualities of Cedar Shingles.

The owner (name on request) maintains that his fuel bills were actually cut in two.



This Certigrade Cedar Shingle Handbook, prepared by a wood technologist, mailed free on request. One hundred pages detailing the uses, application and technical data. Write the Red Cedar Shingle Bureau, Seattle, Wash., U. S. A., or Vancouver, B. C., Canada.

The F. H. A. Offers Protective Features Tending To Safeguard Building Investments

# CERTIGRADE

*Red Cedar* **SHINGLES** *Shingles*

Certigrades pass official inspection for grade and quality



A LABEL SIMILAR TO THIS ONE, MARKED 'SHINGLE' OR 'NO. 1', OR 'NO. 2', IS APPLIED TO ALL CERTIGRADE SHINGLES.

Sold only by established lumber dealers



# Porcena PORCELAIN ENAMEL TOILET PARTITIONS

Porcena Panels possess the natural structural strength of steel (not one sheet but two 16 gauge sheets securely bonded on opposite sides of dense insulating core) strengthened by porcelain enameling (four layers) which provides a non-porous, flint-hard glass-smooth surface that is positively impervious to odors, acids and moisture.

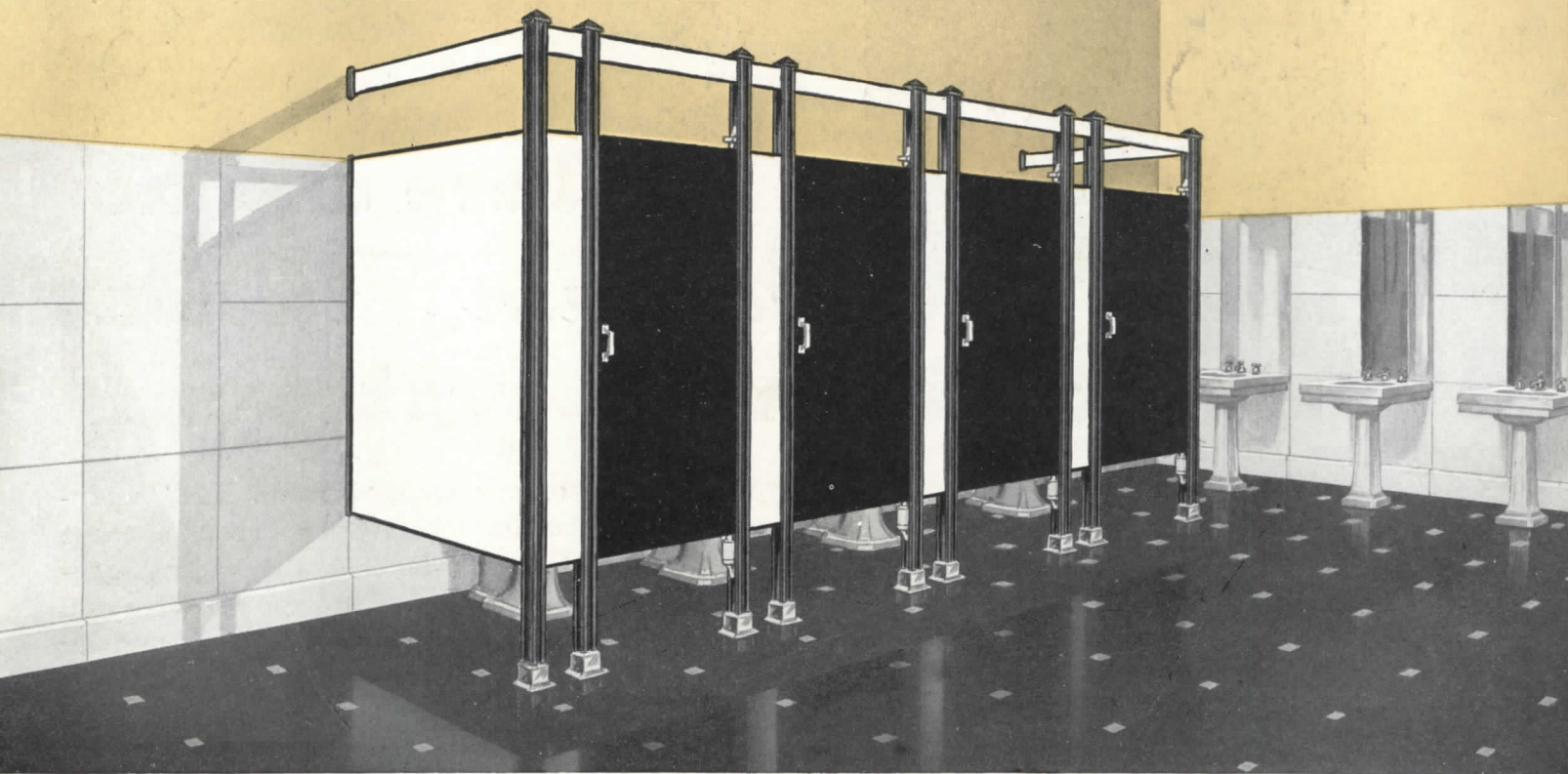

## A TOILET ROOM ENVIRONMENT THAT IS IN STEP WITH *present day standards for better living*

● Toilet room environments can favorably influence the opinion and sentiment of people in every walk of life who work in or visit public and semi-public buildings . . . employees of industrial enterprises and school and college students.

The toilet room environments created by Sanymetal Porcena Toilet Partitions are in keeping with present day standards for better living. They create a smart, up-to-date toilet room atmosphere that arouses a sense of well-being, returning rich rewards in good will.

Besides promoting a new era in toilet room environments, Porcena Partitions also provide a generous margin of years against obsolescence. Their modernity will long outlive less appropriate materials. Colors are permanently fast and their lively brightness a desirable and striking contrast to the somberness that has so long prevailed in toilet rooms. Porcena's flint-hard porcelain enamel finish is non-porous . . . cannot absorb odors, is moisture and rust proof, and resists the corrosive nature of ordinary acids. Simplicity of design facilitates the modernization of present toilet rooms.

The Sanymetal representative near you will be glad to help you plan modern toilet room environments in old, as well as new, buildings of every type. See Sanymetal's new catalog in Sweet's. Write for colorful brochure featuring modern toilet room environments.

The first to originate and offer a definite style of toilet partition and wainscot panel utilizing porcelain enamelled panels, Sanymetal presents a wider scope for the creative talents of a patient profession and protects the building industry in the use of such materials by years of accumulated engineering and craftsmanship experience in the manufacture of certain exterior parts of porcelain enamelled metal.

Craftsmanship  
in Metal



The Sanymetal  
Symbol

Sanymetal's Catalog is contained in Sweet's for 1938 identified as catalog 20/24.

# Sanymetal

TOILET AND OFFICE PARTITIONS

THE SANYMETAL PRODUCTS CO., INC.

1689 Urbana Road, Cleveland, O.



S. H. Kress & Co. Building, one of thousands conditioned with Auditorium Systems.



# There are no "Bargain Sales" on air conditioning systems!

Air Conditioning cannot be bought or sold on a price basis alone. Any apparent saving from a system only partly efficient, designed or built without sufficient engineering skill, soon becomes an added cost—not only for operation but in service failure as well.

The fundamental purpose of air conditioning is to provide relief from uncomfortable outdoor conditions. Subjecting people to sudden changes in temperature, to cold drafts, to a damp, clammy atmosphere, is not providing relief or comfort. It is, however, creating ill-will, against the owner of the faulty system and toward the science of air conditioning in general.

Why invite costly criticism, loss of prestige

and patronage with "bargain sale" equipment. An Auditorium System, such as those installed for thousands of the leading institutions, buildings and stores, will give you the best in air conditioning and actually prove less expensive to own. Through its exclusive Auditorium features it will give a maximum of correct conditioning with a minimum of refrigeration and maintain its efficiency at all loads, partial or full. Ask any of our Licensees about PERMISSION to install a Licensed Auditorium System.

Full details may be secured from any of these Licensees, their branch offices or dealers.

## AUDITORIUM CONDITIONING CORPORATION



New York Office . . . . 17 EAST 42nd STREET

For Auditorium Systems in Canada and List of Canadian Licensees Address—  
Auditorium Air Conditioning, Ltd.—Dominion Square Building, Montreal

- AUDITORIUM LICENSEES**
- American Blower Corporation  
Detroit, Michigan
  - Buffalo Forge Company  
Buffalo, New York
  - Carrier Corporation  
Syracuse, N. Y.
  - Frick Company  
Waynesboro, Pa.
  - General Electric Co.  
Schenectady, N. Y.
  - J. O. Ross Engineering Corporation  
New York, N. Y.
  - B. F. Sturtevant Co.  
Hyde Park, Boston, Mass.
  - Westinghouse Electric & Manufacturing  
Company - - - East Pittsburgh, Pa.
  - York Ice Machinery Corp.  
York, Pa.

**BEAUTY... DURABILITY...  
OUTSIDE INSTALLATION...**

# Pittco Metal provides them all!

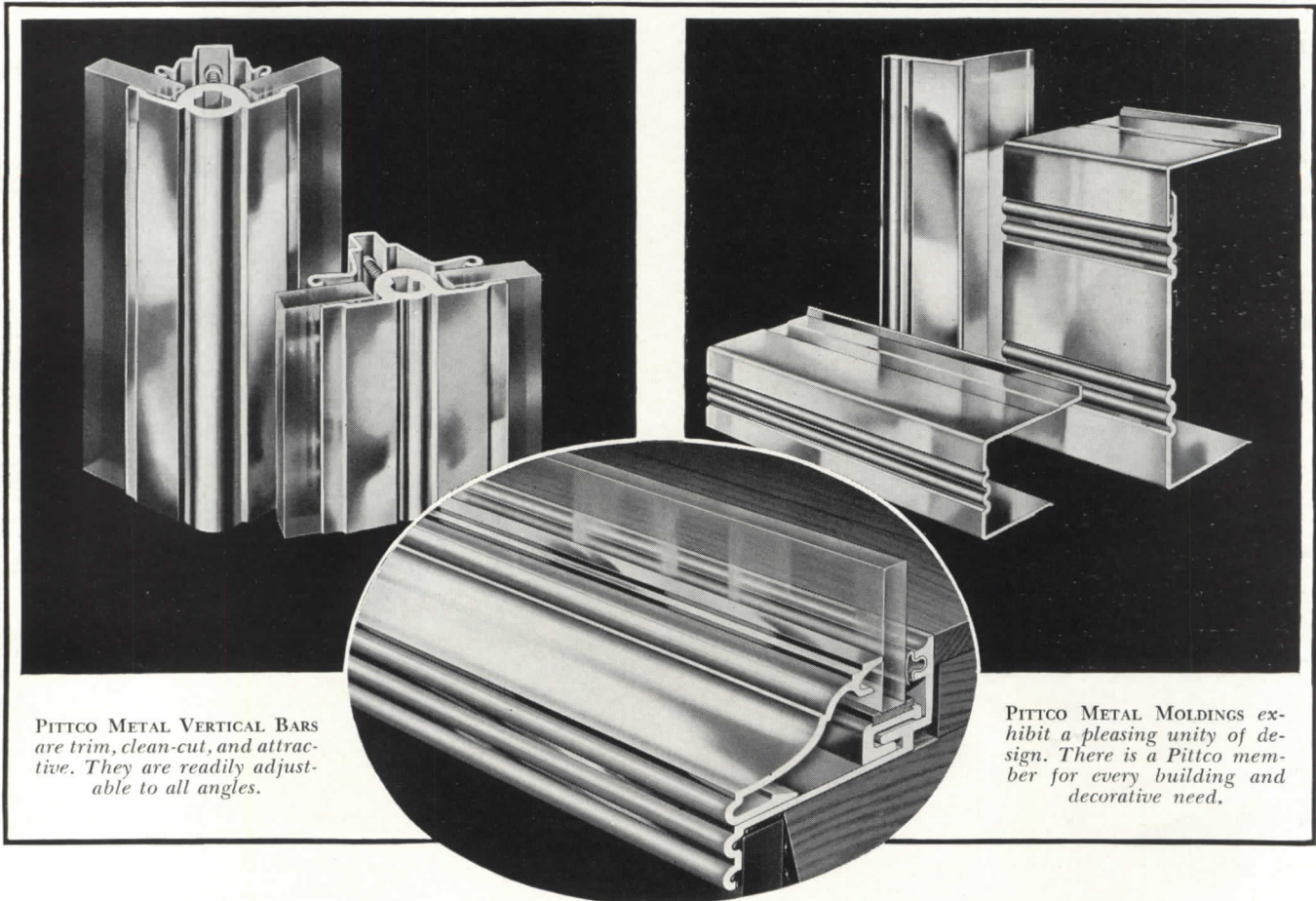

PITTCO METAL VERTICAL BARS are trim, clean-cut, and attractive. They are readily adjustable to all angles.

PITTCO METAL MOLDINGS exhibit a pleasing unity of design. There is a Pittco member for every building and decorative need.

**P**ITTCO Store Front Metal bars, moldings and sash display a rare harmony and unity of design. They are meant to be used together . . . to bear a pleasing relationship to each other on the finished job. And they are available in the smartest of modern finishes . . . Alumilite (anodized aluminum) and bronze, polished or satin finish. Consequently, they afford a new kind of beauty in the store front construction field. They add immeasurably to a store front's good looks and sales appeal.

PITTCO METAL SASH is beautiful and practical. All setting operations are performed from the outside.

Further, all Pittco members are sturdy, strong and tough, though unusually graceful in design. This means that they have the durability to last . . . even under severe usage.

Installation is a simple matter, too. For all Pittco Metal setting operations take place on the *outside* of the show window. Both sash and glass are installed in this manner, without

complications or delays. No special keys or tools are required. A screw driver, plus ordinary wood or machine screws, does the job.

Investigate this store front metal before you design your next store front job. Send the coupon for our file folder containing complete information and detail drawings of various applications.

**PITTCO**  
STORE FRONT METAL

*Paint* \* **PITTSBURGH** \* *Glass*  
**PLATE GLASS COMPANY**

Makers of WALLHIDE PAINT • WATERSPAR ENAMEL AND VARNISH • SUN-PROOF PAINT • FLORHIDE • POLISHED PLATE GLASS • MIRRORS • PENNVERNON WINDOW GLASS • DUPLATE SAFETY GLASS • PITTCO STORE FRONT METAL • Distributors of PC GLASS BLOCKS and CARRARA STRUCTURAL GLASS

Pittsburgh Plate Glass Company,  
2207A Grant Bldg., Pittsburgh, Pa.

Please send me, without obligation, your folder containing full information on Pittco Store Front Metal and detail drawings.

Name.....

Street.....

City..... State.....

# NASSAU TAVERN at PRINCETON, N. J.

Thomas Stapleton, Architect • W & J Sloane, Collaborators

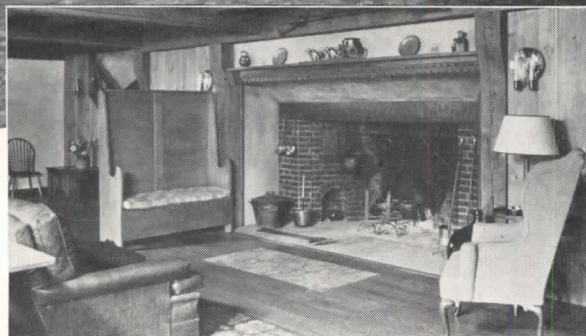
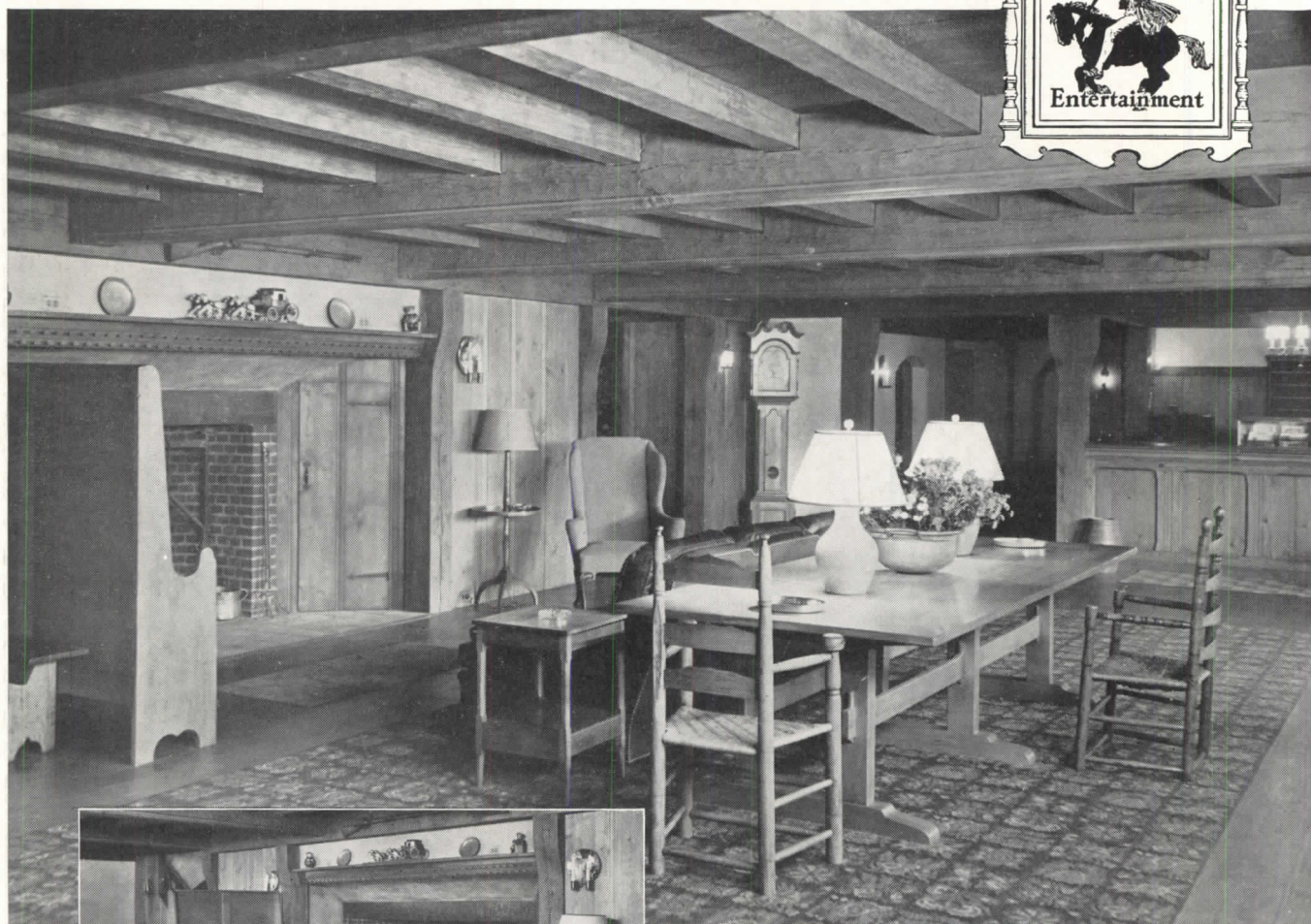

**T**homas Stapleton, noted New York architect, brought boundless enthusiasm into his construction of the Nassau Tavern at Princeton, and W & J Sloane enjoyed their part of the work in making exact reproductions of some of the finest examples of Early American furniture for the great hall and for all the suites and guest bedrooms. Says Mr. Stapleton of the project:

"Replacing the 191-year-old Nassau Inn, the new

Nassau Tavern at Princeton has been conceived as a place steeped in the tradition of the Colonial period, which had to meet changing conditions and expand. The Contract Division of W & J Sloane worked with us in creating the furniture and decorations in the spirit of the Tavern. The study and effort they gave to this project is to be highly commended and we are well pleased with the results."

The wide facilities of Sloane's Contract Division are available to architects in any city. We invite the opportunity of discussing, without obligation, the furnishing and decorating of institutions, clubs, hotels and offices. Sloane services include draperies, wall covering, floor covering, partitions, panelling, and both standard and custom-made furniture.

*Contract Division*

W & J

## Sloane

575 FIFTH AVENUE • NEW YORK

# Approved

by Investigating Committees of ARCHITECTS and Engineers

Official Bulletin of Approved Products—Investigating Committees of Architects and Engineers

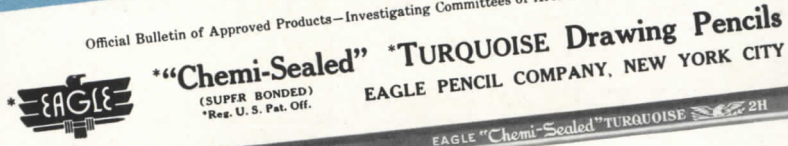

16-c 4-r  
"CHEMI-SEALED," "TURQUOISE"  
DRAWING, "CHEMI-SEALED" (SUPER BONDED)  
\*Reg. U. S. Patent Off.

Investigating Committees of Architects and Engineers is a national association of committees organized to investigate anything of interest to an architect or an engineer in connection with the construction or equipment of buildings. The members of the committee, whose report follows, have been selected from the offices of practicing architects and engineers of high standing in their respective professions for the express purpose and are competent and absolutely unbiased. The activities of the organization are financed from the profits on the sale of pencils to manufacturers who have won approval. The addresses of the members of this committee will be furnished any architect or engineer upon application to Ralph Moreton Hooker, General Secretary, Box 72 Church Street Annex, New York.

grinding by which the particles of graphite and clay are reduced to such microscopic fineness and so thoroughly dispersed in the lead mixture, that it passes through a screen of 40,000 meshes to the square inch. Turquoise leads are formed by extrusion through diamond dies under 60 tons pressure, then fired at

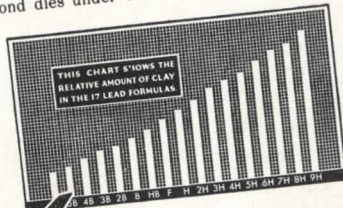

Full approval of Eagle "Chemi-Sealed" Turquoise Drawing Pencils and other "Chemi-Sealed" pencils is hereby granted to the Eagle Pencil Company of New York by the Investigating Committee of New York architects and engineers.

an extremely fine-celled, of even, slow-wearing qualities and unusual strength under breaking tests. For added smoothness, the leads are impregnated with lubricating waxes, then coated by a patent chemical process with an impervious film which prevents any oxidation of the wax by the wood pebbled against change of ageing of the pencils varying seasonal or room temperatures.

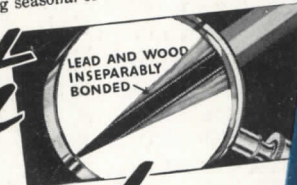

investigation of the above pencils and upon a thorough inspection of the plant processes of manufacture, methods of testing, particularly interested in the "Chemi-Sealed" pencils, the variety of their grading, and especially the opacity of sharp, clear blue lines. The pencils are made in 17 separate lead formulas, giving lead of uniformity spaced in 17 unvarying degrees of hardness. This great improvement upon the method of two degrees of hardness is especially impressed upon the methods of

Turquoise leads also have a smooth surface by which the wood, greatly increased strength of the pencil. Point pressure showed a resistance so far beyond normal use that pencil points worn as

for  
Accurate Grading  
Sealed-in Smoothness  
Point Strength  
Durability and  
Blue Printing Quality

INVESTIGATING COMMITTEES OF ARCHITECTS AND ENGINEERS, Box 72 Church Street Annex, New York  
Copyright 1937 by RALPH MORETON HOOKER, General Secretary. Registered in U. S. A.

WRITE FOR COMMITTEE REPORT and a free TURQUOISE pencil in any grade. Please give your supplier's name and address and mention this publication.

EAGLE PENCIL CO. 703 E. 13th St., New York

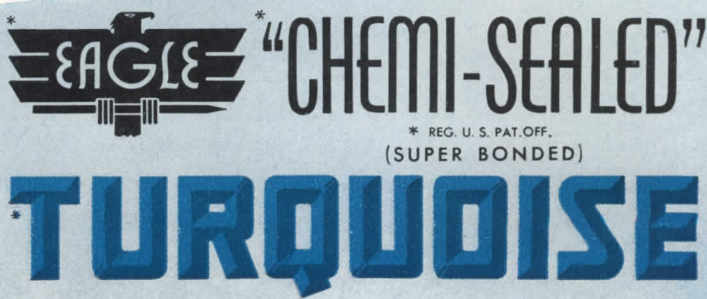

# GEORGE WASHINGTON

## sat in Pew 41

*Today a U·S·S TERNE ROOF  
guards this Famous Historic Church  
from Lightning, Fire, Rain, Snow and Ice*

ST. PETER'S Church, Philadelphia, an excellent example of Georgian architecture, is still well preserved after 177 years. It contains many priceless relics of the revolution. To give the structure maximum protection against the ravages of time and weather, it was re-roofed with U·S·S Ternes—the same type of roof to which so many of the old colonial buildings owe their extremely long life.

Modern U·S·S Ternes, however, offer the additional protection of a copper steel base which has more than twice the atmospheric corrosion resistance of plain steel. Properly applied and maintained, U·S·S Ternes armor a building with a water-tight, fire-proof sheath of steel that could reasonably be expected to give decades of satisfactory service.

U·S·S Ternes are lower in first cost than comparable roofs. They are light in weight, can be used in any climate for any slope of roof from flat to vertical. For these reasons, they are suitable for all types of buildings.

Look for complete information in Sweet's Catalog or write to our nearest district office.



*St. Peter's Church, Philadelphia, built in 1761, is one of the oldest buildings in America. The original wooden fence was taken for fuel by the British, but the interior still retains the high-backed box pews, President Washington's among them, pew 41. This priceless historic relic is protected from weather by a roof of U·S·S Ternes.*

## U·S·S ROOFING SHEETS *and* TERNES

CARNEGIE-ILLINOIS STEEL CORPORATION

Pittsburgh



Chicago

Columbia Steel Company, San Francisco, Pacific Coast Distributors

United States Steel Products Company, New York, Export Distributors

# UNITED STATES STEEL





EASY OPERATING  
GARAGE DOORS  
ARE NO LUXURY!

**EVEN A MODEST ALLOWANCE**  
*Can Include*  
**STANLEY "ROLL-UP" DOORS**

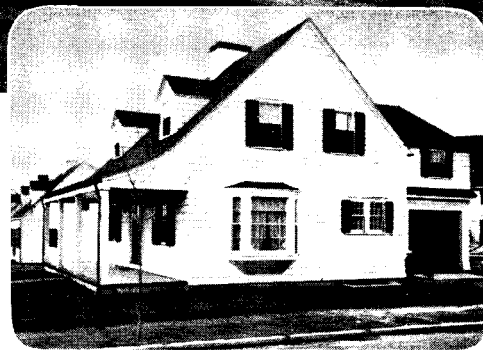

No doubt about it! Now, more than ever before, the nation's attention is focused upon the small, inexpensive home. Garages, once "orphans" of the building plan, share this attention — clients expect and get top value in modern appearance and complete utility. The convenience and smooth operation of Stanley "Roll-Up" Doors and Hardware appeal to everyone. Even with a limited allowance you can include this modern equip-

ment. Specify Stanley "Roll-Up" Doors and Hardware for easy installation, trouble-free long life. No sticking, no jamming, a slight lift starts the door — heavy coil springs roll it up into position — works even when snow-banked . . . Your local Stanley Dealer can supply this equipment promptly. Write today for Catalog No. 38 containing full details and specifications. The Stanley Works, New Britain, Connecticut.

**STANLEY**

**H A R D W A R E F O R C A R E F R E E D O O R S**

You say we'll have  
perfect temperature  
all year 'round and  
yet save money on  
our operating cost.

— How?



. . . . The answer  
complete Minneapolis  
Honeywell Automatic  
Controls. We recom-  
mend and specify  
them for every



*Inseparable!*

**MINNEAPOLIS-HONEYWELL**  
AUTOMATIC CONTROLS AND ...

**AUTOMATIC HEATING AND TRUE AIR CONDITIONING**



MINNEAPOLIS-HONEYWELL REGULATOR CO., 2804 FOURTH AVE. SO., MINNEAPOLIS, MINN  
BROWN INDUSTRIAL INSTRUMENTS • NATIONAL PNEUMATIC CONTROLS

# BUILDING TYPES



*Gustaf Anderson*

**HOUSES — \$7,500 and under**

ARCHITECTURAL  
RECORD

# The Small One-Family House

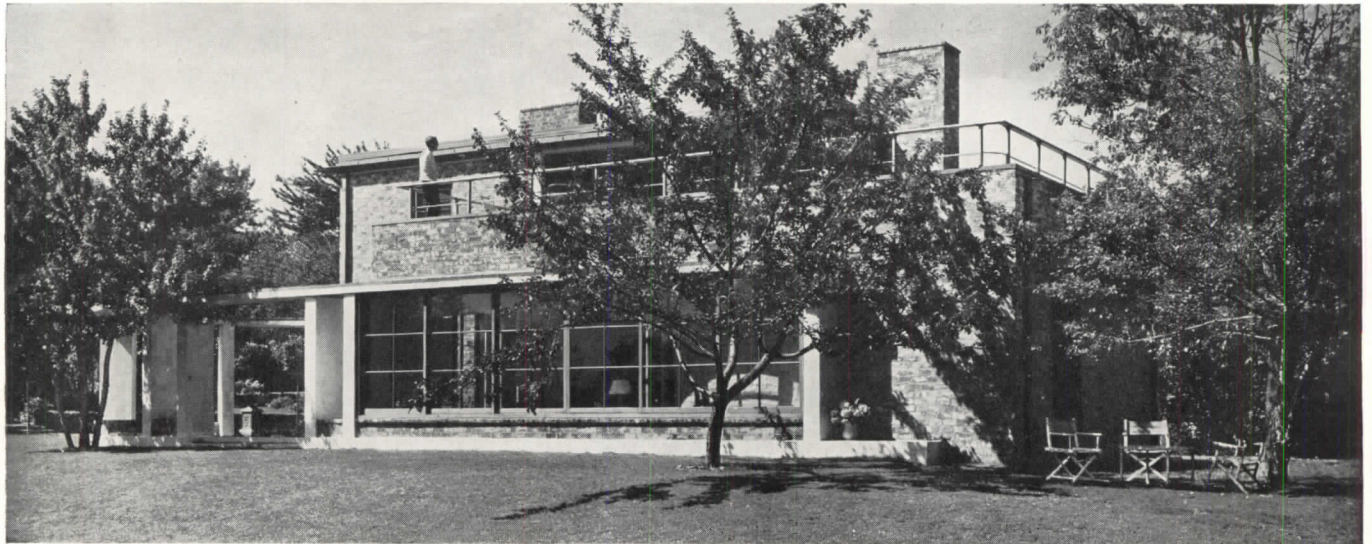

F. S. Lincoln

**This is the first of four Building Type studies on Houses that will be published during 1938. It deals with the small one-family house costing not over \$7,500, without land or service fees and is based largely upon results of a questionnaire relating to occupancy requirements and current methods of meeting them.**

NEITHER size, type or location establishes a common ground for any constructive discussion of the single-family house. The title of this study—"The Small One-Family House"—is definitive only as amplified by the bold-face type that heads these columns. For, since cost is—whether erroneously or not—the most commonly accepted measure of housing "value", the phrase "... costing not over \$7,500 without land or service fees" provides a general reference frame within which highlights of the subject can be concentrated.

Even upon this basis, the question "How much house for \$7,500?" has no generally applicable answer. Variations in family requirements, living habits and personal tastes; the influence of local building customs; fluctuations in costs of building labor and materials—all these can combine in many ways. All have a bearing upon the qualitative solution of a designer's

problem. And each may be, in itself, a question of such major importance that even a specific cost bracket may seem inadequate as a common ground for discussion.

These matters have been individually mentioned many times before. Some have been researched locally. But little effort has so far been made to investigate them collectively—to discover, if possible, their relative influence upon current house design and to study means by which such influences may be integrated toward the betterment of houses for the American family with modest means.

As a first step toward this type of research study—which, if sufficiently broad, would produce data of a pointed social, economic and technical significance—editors of the RECORD developed a questionnaire on the \$7,500 house. It was circulated to approximately 1,000 building designers scattered throughout the states east of the

Rockies. Returns were separated into localities, carefully tabulated, checked and compared and used as a basis for the major portion of this study.

The RECORD questionnaire was designed to reflect local influences of cost variation, living customs and public demand upon the design—a term used in its most inclusive sense—of the \$7,500 house. It was composed of two parts, one dealing with the owner's requirements, the other with methods used by the designer in meeting them in view of local limitations of cost and size influencing planning, construction and equipment.

On the opposite page is reproduced the first portion of the questionnaire. It is included for two reasons. First, it offers a basis upon which a designer can profitably develop individual questionnaires to aid him in establishing client requirements for any type of house. But more important, it embodies an approach to residential design which, if not entirely new, is unusual in the \$7,500 cost classification.

Many such houses in all parts of the country serve to uphold the contention of articulate designers—and owners—that the buyer of an average, moderate-cost house gets little for his money in the way of convenience and modern livability. Even considering

*(Continued on page 136)*

# OCCUPANCY REQUIREMENTS—A BASIS FOR SMALL HOUSE DESIGN

## A—GENERAL LIVING ACTIVITIES: conversing, reading, writing, entertaining, dancing, resting, etc.

1. Space needs (size and shape of areas; minimum or average heights).....?
2. Preferred location (first or second floors and relative to other parts of house. Orientation for sun and prevailing winds).....?
3. Natural lighting (size and type of windows).....?
4. Electric light (location and character of fixtures, wall, ceiling and portable).....?
5. Color preferences.....?
6. Construction and finish (as heat and sound insulation, wall and floor finish).....?
7. Storage (built-in cases, cabinets, etc.).....?
8. Is equipment required for multiple use of space (as built-in desk or table, window seat, folding bed, radio and telephone cabinet).....?
9. Accessibility (relation to other parts of house by doors, halls, etc. and to outdoor porches, terraces, gardens).....?
10. Heating, ventilating and air conditioning (location and character of radiators, grilles, fireplace, etc.).....?

## B—CULINARY ACTIVITIES: preparation, cooking and serving food, cleaning, washing, storing dishes, utensils, etc.

1. Space needs and preferred location (area relative to family size; first floor, basement or second floor, front, rear, side of house, etc.).....?
2. Arrangement (as U-, L-, T-shaped, corridor or other).....?
3. Storage (amount and type required relative to family size).....?
4. Mechanical equipment (type and sizes of stove, sinks, dishwashers, food mixers and miscellaneous, electric units, waste disposals, water heaters, refrigerators, ventilators, etc.).....?
5. Lighting (location, size and type of windows; type and location of general and local fixtures).....?
6. Preferred colors and finishes (floor, walls, counter-tops, equipment).....?
7. Is multiple use of space required (as eating, sewing, laundering, child-caring, reading, writing, etc.).....?
8. Does such use require added space or equipment (as built-in dining table and chairs; built-in or portable desk; radio-clock, etc.).....?

## C—DINING ACTIVITIES: eating, drinking, smoking, group entertaining, serving, clearing away, storing, etc.

1. Space needs (shape, size, height, relative location, as basement, first, second floor, etc.).....?  
Is separate dining space preferred.....?  
Can it be combined with general living areas.....?  
Provided within kitchen area.....?  
or both.....?
2. Relative accessibility (doors, halls, etc.).....?
3. Storage (as built-in cabinets, buffets, bars, etc.).....?

4. Lighting (as size and type of windows for natural light; type of general and local electric light).....?
5. Color and finish preferences.....?
6. Is multiple use of space required (as entertaining, studying, game-playing, etc., involving built-in desks, tables, additional storage, etc.).....?

## D—REQUIREMENTS FOR RESTING, SLEEPING, DRESSING, etc.

1. Space needs (sizes and shape) for one adult.....?  
For two adults.....?  
For one child.....?  
For two children.....?
2. Locations (first or second floor and in relation to privacy, for accessibility to sanitary facilities and other parts of house, etc.).....?
3. Storage equipment (portable or built-in closets, cabinets, etc.) Sizes and shapes for one adult.....for two.....?  
for one child.....for two.....?
4. Is other built-in equipment required (as fitted wardrobes, dressing tables, lighted mirrors, etc.).....?
5. Is added space needed for this (dressing rooms, dressing closets, etc.).....?
6. Is separate sleeping space required (bed alcoves, built-in double-deck beds, etc.).....?
7. Is multiple use of space necessary (as reading and writing, studying, child-caring, lounging, sewing, game-playing, etc.).....?
8. How much does this involve added space or equipment (as built-in benches, tables, beds, cases, cabinets, radios, telephones, maps, etc.).....?
9. Lighting (as size, type and location of windows for natural light; and types of fixtures for electric lights).....?
10. Heating, ventilating and air conditioning and controls of these.....?
11. Construction and finishes (necessity for sound or heat insulation, treatment of floor, walls, ceiling, built-in equipment).....?
12. Special outlets for water and power, etc. ....?

## E—SANITATION ACTIVITIES: bathing, shaving, toileting, child-caring, re-fusing, etc.

1. Space needs (number and location of spaces; sizes and preferred equipment units of each, etc.).....?
2. Natural and electric light (number and type of windows and fixtures).....?
3. Other mechanical equipment (as heating, ventilation, special fixtures, electric outlets, etc.).....?
4. Construction (necessity for sound or heat insulation, waterproofing, etc.).....?
5. Preferred colors and finishes (floor, walls, ceiling, fixtures, etc.).....?

6. Storage (medical cabinet, towel and linen shelves, etc.).....?

## F—HOUSEKEEPING ACTIVITIES: cleaning, laundering, servicing heating plant, repairing, storing things, etc.

1. Space needs (preferred locations, shapes, sizes, etc.; also fittings as shelving, cupboards, lights, air vents, etc.).....?  
A... for Sewing.....?  
B... for Laundering (in view of mechanical or storage equipment for collecting, sorting, washing, drying, ironing, folding, etc.).....?  
C... for Servicing Heating Plant (including requirements for fuel storage; also air conditioning and hot-water supply units, etc.).....?  
D... for Other Mechanical Equipment (as water softeners, pumps, gas and electric meters, etc.).....?  
E... for Heavy Storage (as fuel, screens, awnings, storm sash, etc.).....?  
F... for Staple Storage (as canned goods, preserves, wines and liquors).....?  
G... for Storage of Maintenance Materials (mops, brooms, vacuum cleaners, polishes, cleaning compounds, etc.).....?  
H... for Storage of Personal Effects (as winter outdoor clothing, umbrellas, etc.).....?  
I... for General Servicing (repairing, painting, etc.).....?  
J... for Linen Storage (sheets, towels, blankets, etc.).....?

## G—RECREATIONAL ACTIVITIES: games, parties, billiards, table-tennis, card-playing, group singing, hobbies, etc.

1. Space needs (shape, size, location, etc.).....?
2. Mechanical Equipment (as special water and electric outlets, heating, ventilating and air conditioning, etc.).....?
3. Special constructions (as waterproofing, heat and sound insulation, wall, floor, ceiling treatments).....?
4. Storage (type and sizes for outdoor equipment and indoor units of all types).....?
5. Accessibility (to outdoors and rest of house).....?

## H—OUTDOOR ACTIVITIES: lounging, gardening, sun-bathing, game-playing, automobiling, bicycling, etc.

1. Type of space required (as open terraces, covered porches, attached or unattached garages, etc.).....?
2. Location (relative to privacy, to accessibility from rest of house, orientation as to sun and air, etc.).....?
3. Sizes and equipment (as storage facilities, outlets for water and electricity, etc.).....?



Gustav Andersen

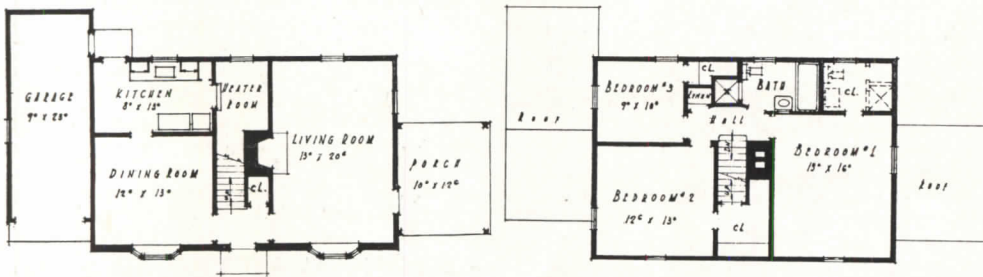

## "MODEL HOUSE" DESIGNED FOR SALEABILITY

This house—called "The Standish"—is located at Harbour Green, Long Island, N. Y., one of several successful residential developments controlled by the Harmon National Real Estate Corporation. Designed by Randolph Evans, Architect, and built during 1936 at an approximate cost of \$6,000, it represents, according to its designer, ". . . the type of small house desired by and most popular with the majority of families in this part of the country who cannot afford to pay more than \$50 to \$65 per month to buy a home of their own. . . "

Construction is frame on foundations of concrete block. Painted brick is used to veneer the front of the first story; otherwise, the exterior is finished with white-painted shingles. Exterior walls and the ceiling of the second floor are insulated with a flexible blanket of rock wool. The house has no basement, but the heater room is pitted two steps below the first-floor level. The heating system is a gas-fired forced hot-air type that includes winter humidification. Kitchen and bathroom equipment are of standardized type and size. Extra storage space in the attic is reached from stairs that lead from a second-floor closet.

Its designer admits that present occupancy requirements are far in excess of those provided for in this house. But, he maintains, "These requirements cannot now be economically provided for in the individually designed small house costing \$7,500 or less to build."

(Continued from page 134)

necessarily strict cost limitations, they are probably correct in saying also that small houses can now be built that are better designed than the average and therefore better adapted in space utilization, construction and equipment to the manifold requirements of twentieth-century living.

The ingenuity of building designers certainly should be equal to the task implied in that statement. Particularly is this true in view of the wide new range of materials, equipment and services that industrial and marketing researches, coupled with progressive improvement in manufacturing productivity are making more and more easily available at constantly decreasing costs.

Proof of this lies in the success of those designers who have forsaken the "traditional" in search of means for more adequate and inclusive provisions for the various everyday activities of American family life. Those activities—bound inextricably with such industrial age products as radios, telephones, automobiles, home movies, air conditioning and all the rest—are traditional only to a limited physical extent. Modern living has opened a wide door to a vast series of new requirements—physical, social and economic—which no "traditional" dwelling ever needed to fulfill.

It is not the job of the building designer to state, exactly, what these requirements may be or to decide upon the relative importance of each. But it is his job to find the means of meeting them in small houses within the limitations of a specific cost classification. And to do this intelligently he must first know what they are and to what extent they may involve technical changes in the type of houses that have been currently available.

As a simple means for obtaining such information, this part of the RECORD's questionnaire was phrased primarily in terms of living activities, rather than in terms of rooms. Thus it allows both owner and designer to consider their joint problem without reference to arbitrary limits that standardized "room living" imposes.

Such an approach to small house design follows generally the practice of industrial organizations. If requirements are charted completely, limitations and possibilities are easily recognized. Technical means for developing these can then be more efficiently selected; and the resulting forms can be justified from all points of view as the natural consequences of a rational designing method.

# Zoned Planning for Noise Control

Analyzed by Harrison Gill, AIA, small house design is largely a problem of planning. And good planning involves an arrangement of living units to minimize disturbing effects of the noise and bustle that characterize the day-by-day living of the normal American family.

THE ORDINARY daily activities of any normal American family fall into two general groups—those that produce noise of some sort and those that need quiet and a relative seclusion for their enjoyment. Unfortunately, activities within each group overlap so far as time and individuals are concerned. Radio-playing may be intensely disturbing to those who are trying to study or to write; and the noise of children's fun can be equally annoying if it continually breaks into the preoccupied quiet of a chess game.

Such personal cross-currents are an inevitable part of a family's life. They can not be eliminated without injustice to some member of a family. But their disturbing effects can be controlled. Even within a small and inexpensive house, conflicting activities can be enjoyed if proper means are provided for them. And these can be provided in every instance by the simple expedient of zoning—by equipping various spaces for particular activities and by combining them so that relative location and construction tend to minimize effects of all types of noise.

Activity areas in any small house can be listed categorically and briefly analyzed as follows:

## Recreation Room:



A place for all noisy activities of a family's leisure time—for indoor games, children's play; for dancing, home movies,

radio programs; for parties at any time of day or night. In area, as large as practicable—from 300 to 400 sq. ft. equipped with built-in furniture and space to store all usual types of recreational equipment. Dining space and equipment are also essential.

## Quiet Room:



For relaxation and those activities that require quiet and seclusion; as lounging, reading, writing, conversation, such games as cards or chess, teas or suppers for small groups. A large area is unnecessary;

but the 100 to 150 sq. ft. should be equipped for storage of books and some games and can advantageously include a built-in desk and day bed whenever possible.

**Kitchen:** An area of 80 to 140 sq. ft. can include all necessary mechanical units in the most efficient arrangement and, in addition, space for informal dining.



**Circulation:** Coat closet, stairs, lavatory and hall are included. All should be easily accessible to work and recreation areas. Area will vary with extent and locations of other living units.



**Garage and Utility Room:** To house car and mechanical equipment, tools, general storage, etc. Garage areas range from 200 sq. ft. for one car to 350 sq. ft. for two cars, both being minimum.

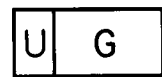

**Bed Rooms and Baths:** Areas will vary, aggregating, at least, about 600 sq. ft. for average family requirements. Bedrooms can be small—from 80 to 120 sq. ft.—and still contain sufficient space for sleeping, dressing and even studying, if required.



Zoning of these spaces depends somewhat upon limitations of the site and the requirements of the family. A functional relation is diagrammed at right with three illustrations of zoning possibilities.

Location of the quiet room is such that other living units isolate it from recreational areas and act as a baffle to noise. Construction of this room involves some soundproofing—shown solid black in the zoning diagrams. Soundproofing—or, more properly, some type of sound-isolation method—will usually be necessary only in one or two walls and in the ceiling of a quiet room.

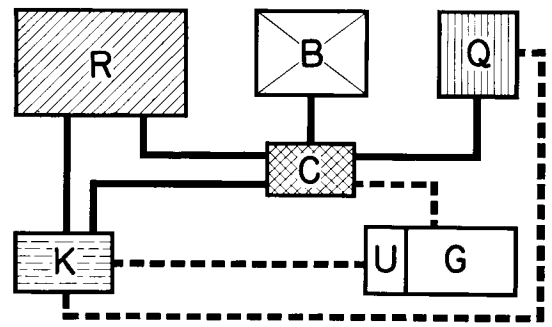

In the diagram above basic living units are linked to a common means of circulation in relation to the functional characteristics of each. Solid lines indicate spaces between which a direct connection is essential; dotted lines indicate where direct connections are desirable.

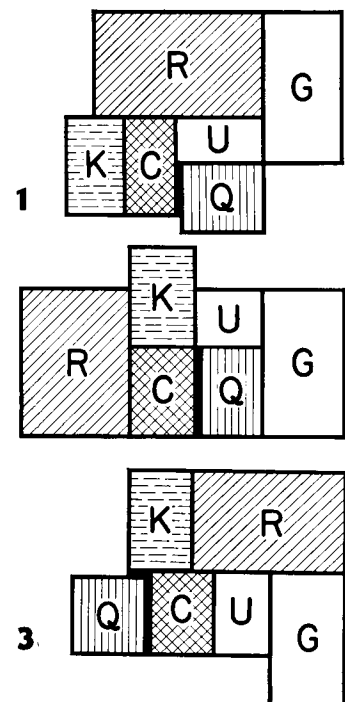

Diagrammatic plan arrangements indicating desirable relations between Recreation and Quiet Rooms for sound isolation. In 1 the Utility Room serves as a baffle between the two; in 2 the sound baffle is Circulation; and in 3 the Quiet Room is isolated from noise by both Circulation and Kitchen. Solid lines indicate walls with structural soundproofing.

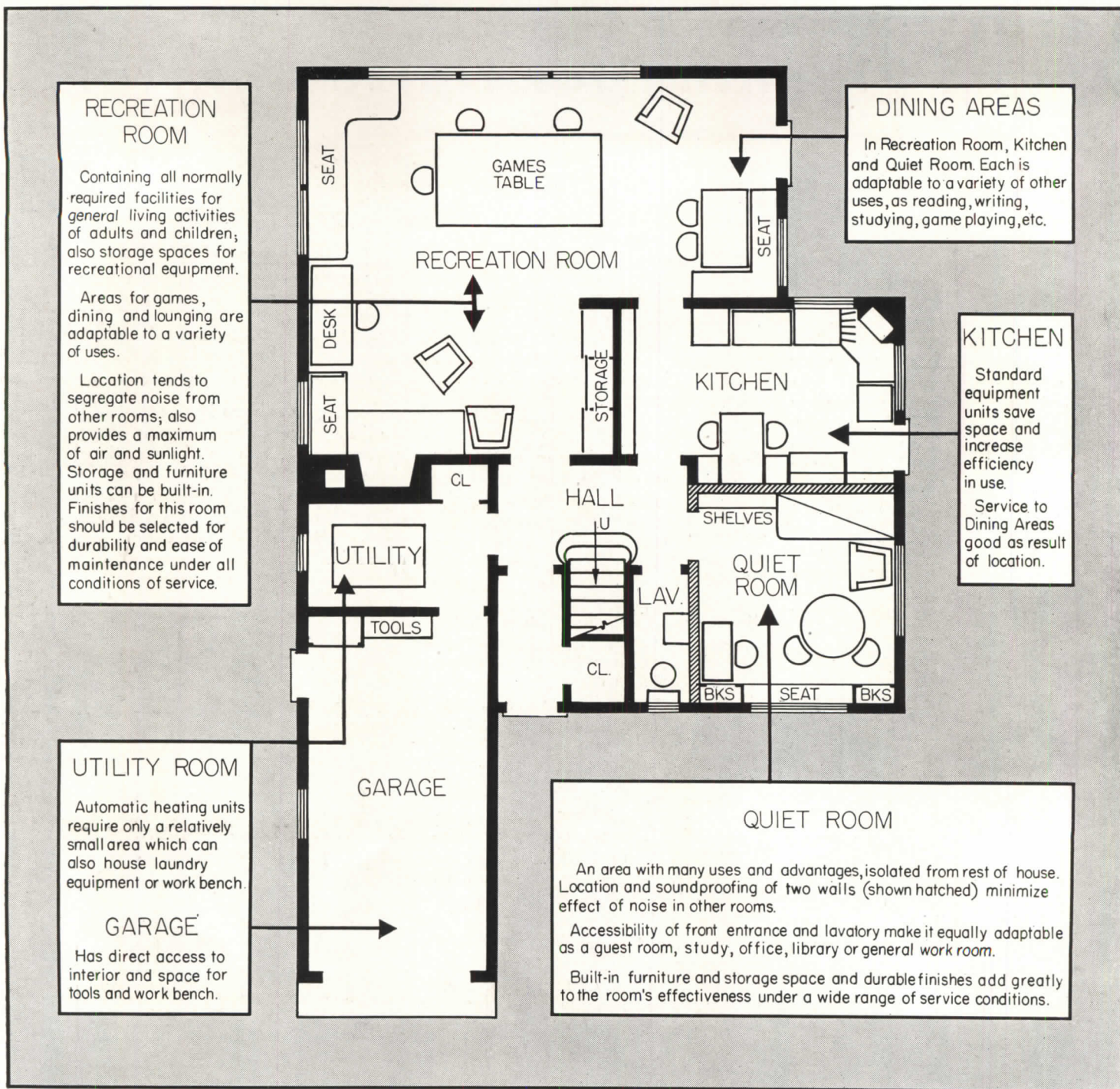

## A Small House for a Family of Five

TO ILLUSTRATE application of his suggestions for minimizing effects of disturbing noises in a small house, Harrison Gill developed the plans reproduced on these two pages. He has assumed conditions encountered in all sections of the country: a small suburban lot; and a family composed of two adults and three children. Because of a modest income they must live within a small, inexpensive house, managed by the mistress without any

day-by-day help of servants.

The house has no basement. Its total floor area is 1,171 sq. ft.; and with average ceiling heights the cubic space would amount to 18,960 cu. ft. Assuming a cubic-foot cost of \$.35—which, obviously, will not be a fair figure in all localities—this house would cost close to \$6,500, without land or any service fees.

A study of the annotated plans will show living facilities that are uncom-

mon in a house of this size and cost classification. A room for general living containing 433 sq. ft. is unusually large. The Quiet Room is equally useful as a study, dining room or guest room. And, on the second floor, minimum planning has provided work space in addition to four bedrooms.

These provisions may require justification, particularly from the standpoint of the money lender, who is prone to lend on the basis of stylized design rather than upon the results of a designing method actuated by re-



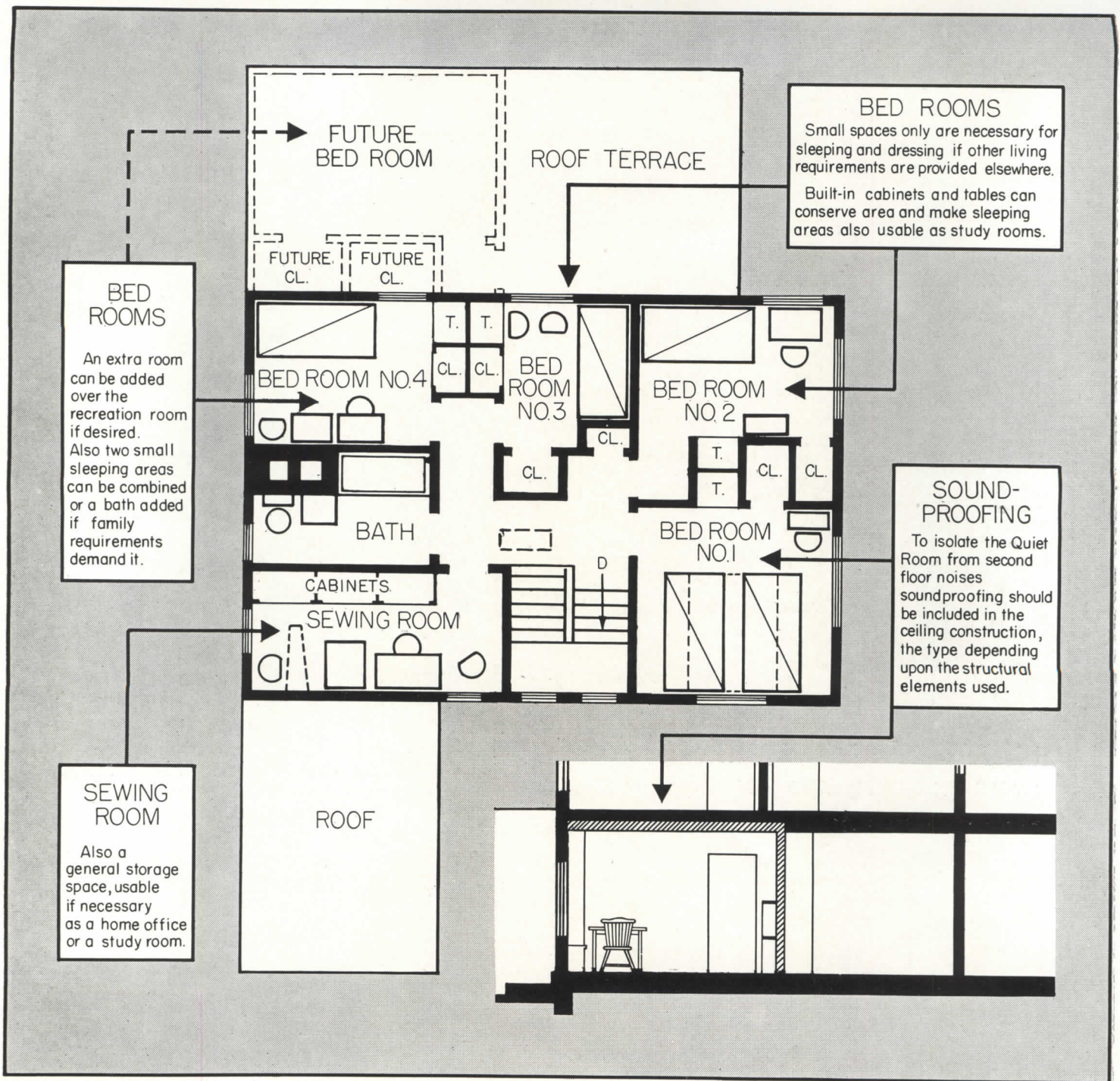

quirements of family living. The following paragraphs are briefed from the designer's experience with clients and his analysis of the space-time utilization of small house interiors.

**First Floor Rooms**

Disturbances occur when interests of children conflict with adult activities. By providing a Recreation Room, sturdily furnished and finished and equipped for noisy play of all family members, interests of the majority are served. The minority who desire quiet are provided with a specially con-

structed space, equipped with facilities for relaxation or studious work. Thus the *effects* of noise are minimized without an attempt to discipline the noise itself out of existence, a condition recognized as desirable by medical authorities.

Efficient, timesaving management of domestic affairs is aided when a kitchen is compact and located so that food service can be made easily available to dining areas in both Quiet and Recreation Rooms as well as in the kitchen itself.

**Second Floor Rooms**

With such relatively complete provisions for general living activities, bedrooms can become small spaces in which to rest, dress and store personal belongings. If fitted with built-in desks in addition to wardrobes, they become individual Quiet Rooms for children and adults. The "Sewing Room" combines storage, domestic workshop and housekeeping office in one room. Built-in equipment offsets size in providing space for required activities.

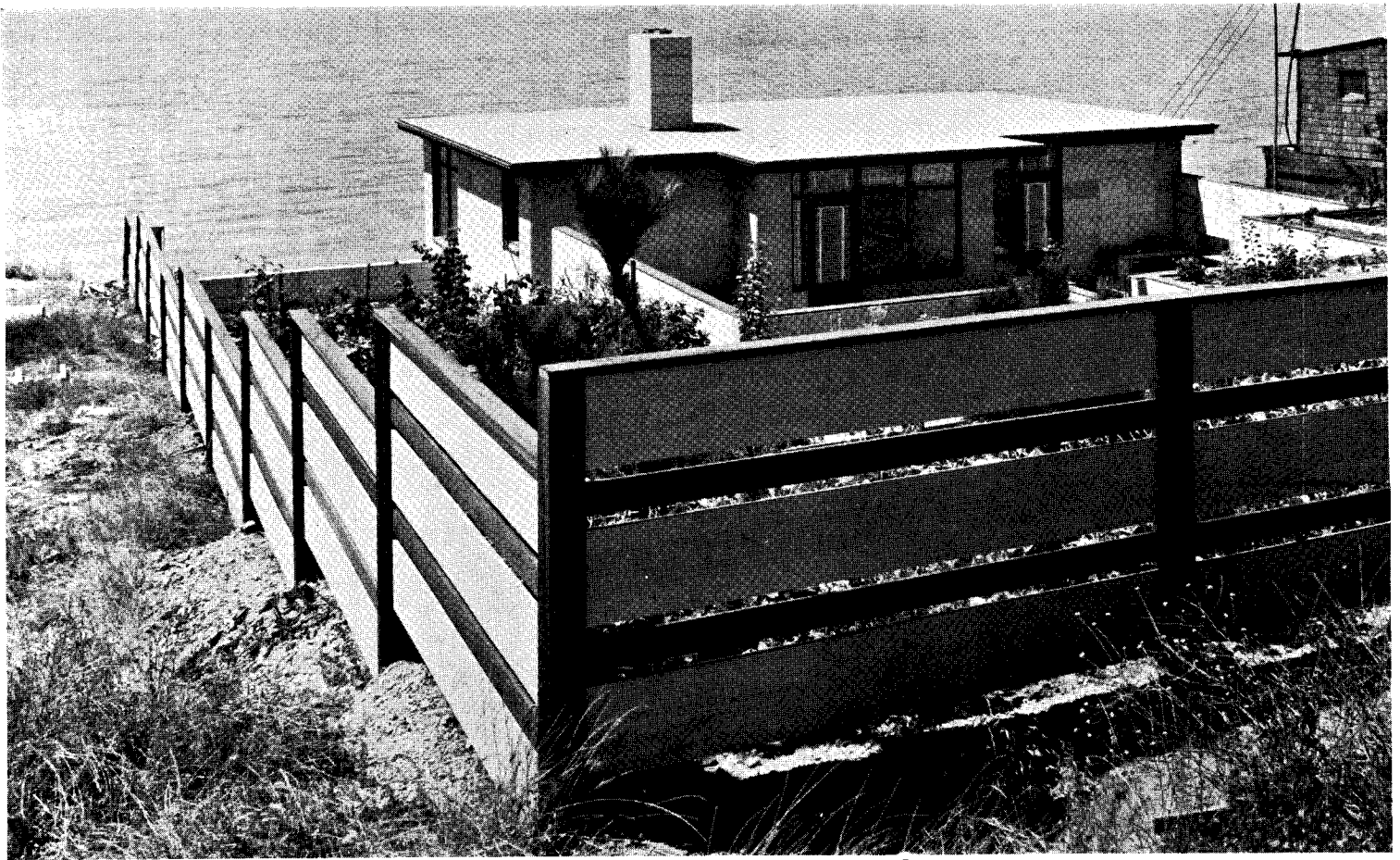

## A FOUR-ROOM HOUSE

MATHURIN DONDO RESIDENCE  
RICHMOND, CALIFORNIA

WILLIAM WILSON WURSTER  
Architect

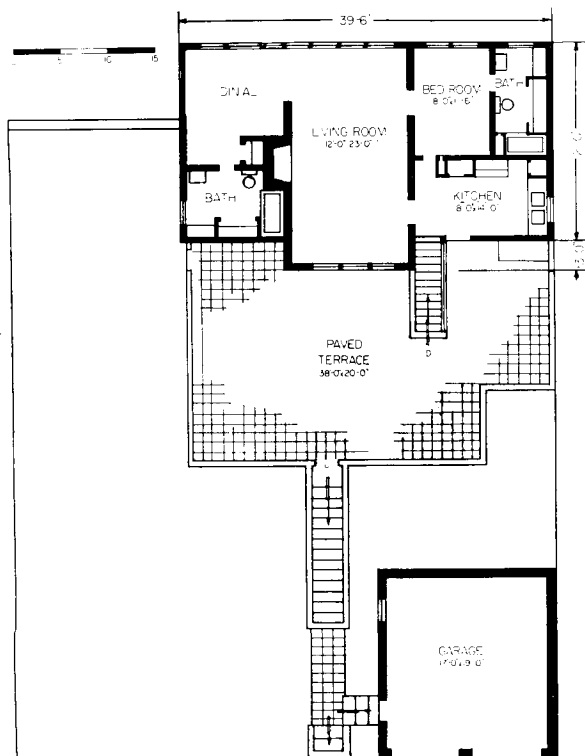

Plan

ON THIS remarkable overlook of San Francisco Bay, the principal rooms are arranged to afford the occupants maximum means of observation. The approach to the house, taking the form of a terrace garden, has been integrated in the design through the use of common materials. Concrete blocks are used in garage, house and for the walls of the terrace; the terrace is surfaced with the same tile used for the floors of the interior living area.

### SCHEDULE OF EQUIPMENT AND MATERIALS

FOUNDATION	Concrete
STRUCTURE	Masonry-bearing
EXTERIOR	
Walls	Concrete blocks
Roof	Built-up tar and gravel surface
Sash	Wood and steel, plate glass
INTERIOR	
Floors	Reinforced concrete slabs, red tile finish
Trim	Redwood
HEATING	Hot-air

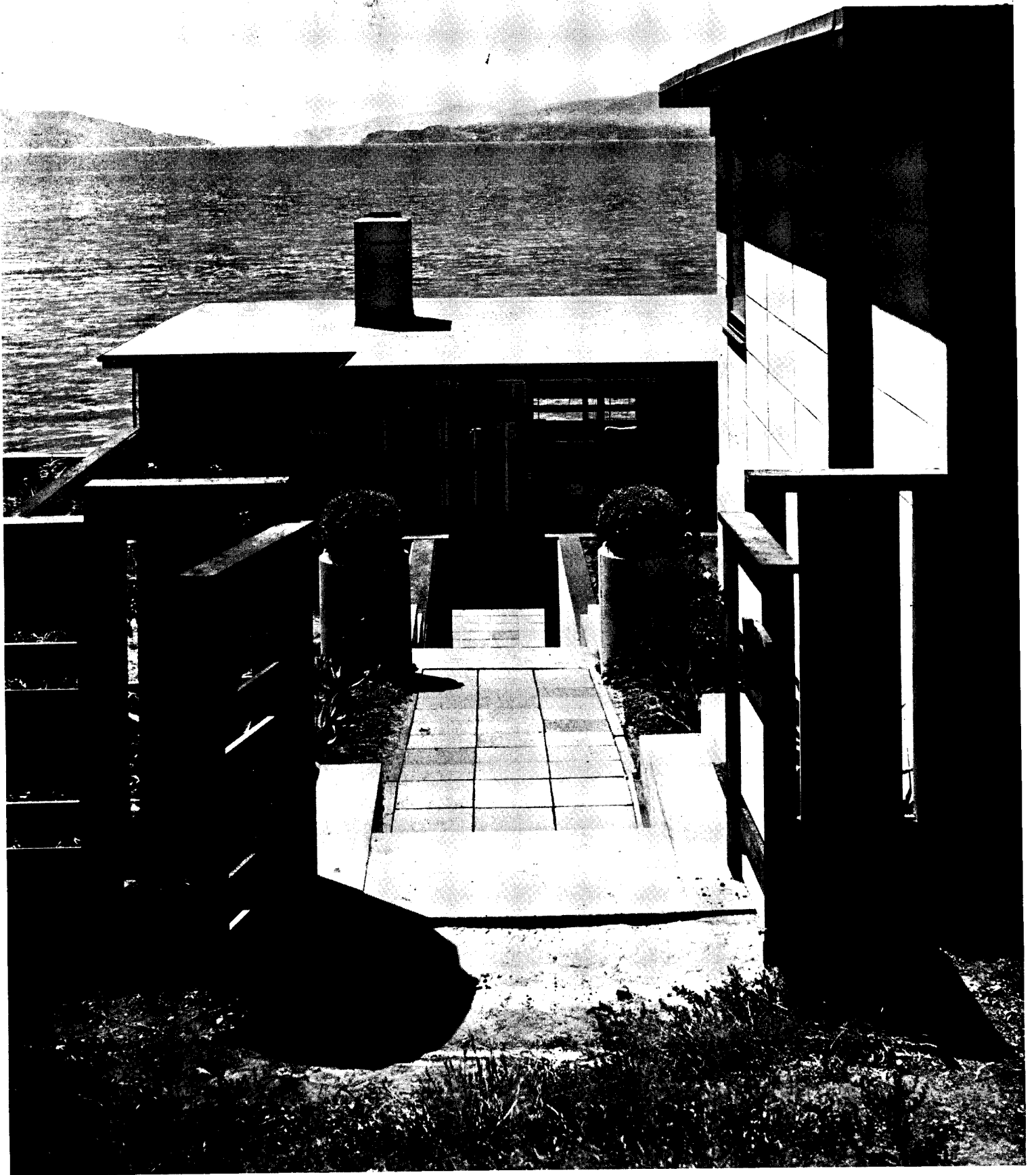



## A FOUR-ROOM HOUSE

WILLIAM WILSON WURSTER

Architect



View of living room looking toward the bay (above) and toward adjoining alcove (right).



## A SIX-ROOM HOUSE

GEORGE WILSON GROVE RESIDENCE  
CORNWALL, CONNECTICUT

ADAMS & PRENTICE  
Architects

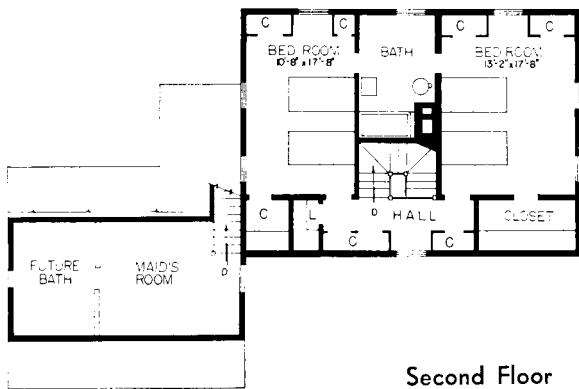

Second Floor

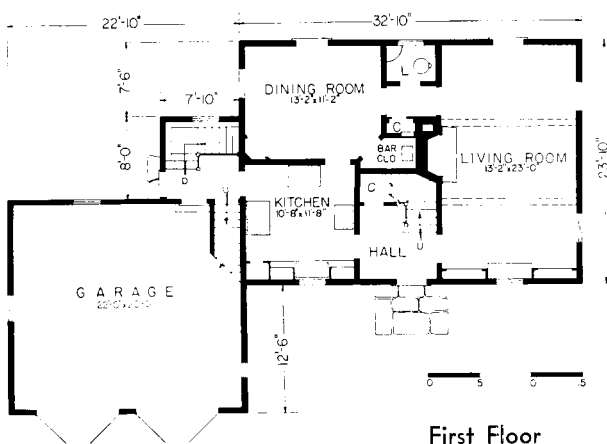

First Floor

### SCHEDULE OF EQUIPMENT AND MATERIALS

<b>FOUNDATION</b>	Stone
<b>STRUCTURE</b>	Wood frame
<b>EXTERIOR</b>	
Walls	Cedar clapboards on $\frac{3}{4}$ " Bilorite Sheathing, Insulite Co.
Roof	Cedar shingles
Sash	Wood double-hung; bronze wire screens
<b>INTERIOR</b>	
Floors	Wood
Walls	$\frac{1}{2}$ " Homasote walls and ceilings; Beaver-Best-Wall tile boards in kitchen and bathroom
<b>HEATING</b>	Pipeless hot-air system, Richardson & Boynton
<b>HARDWARE</b>	Tull Bros., latch type
<b>PLUMBING</b>	Standard Sanitary Mfg. Co. fixtures
<b>PAINTING</b>	Exterior: white Interior: woodwork Natural waxed finish
	Cost: \$6,500, including architect's fee.



## A WEEK-END SEASHORE HOUSE

DR. DAVID KAPP, OWNER  
HARVEY CEDARS, NEW JERSEY

J. JOSHUA FISH  
Architect

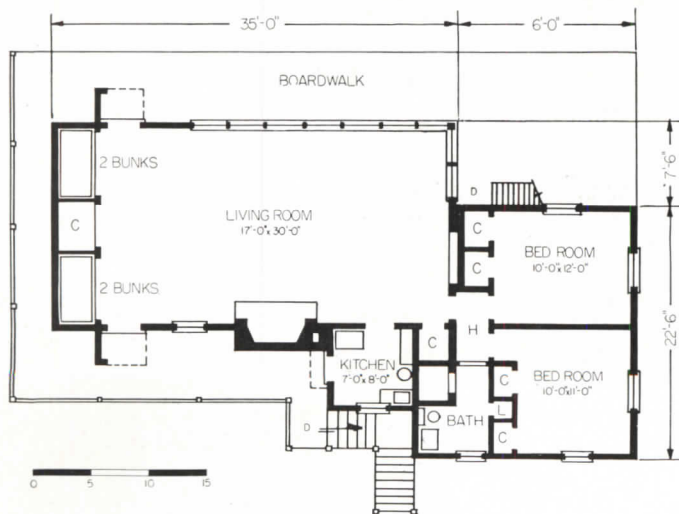
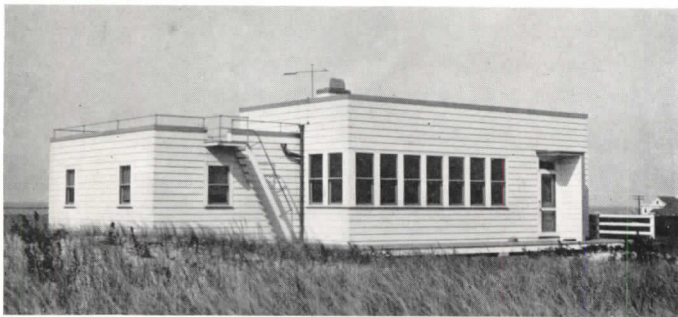

Plan

### SCHEDULE OF EQUIPMENT AND MATERIALS

<b>FOUNDATION</b>	Concrete block on spread concrete footings
<b>STRUCTURE</b>	Wood frame
<b>EXTERIOR</b>	
Walls	Cypress siding
Roofs	Built-up, slag surface; canvas on sun deck
Sash	Wood double-hung, Curtis Co.
<b>INTERIOR</b>	
Floors	Wood
Walls	Homasote
<b>WATERPROOFING</b>	Barrett Co. pitch on walls below grade
<b>INSULATION</b>	Homasote
<b>HEATING</b>	Hot-air, Holland Furnace Co.
<b>PLUMBING</b>	Standard Sanitary Mfg. Co. fixtures; copper tubing
<b>HARDWARE</b>	Solid brass, Corbin
<b>PAINTING</b>	Exterior: white Interior: sea green Aluminum primer; Patton's Sunproof, Pittsburgh Plate Glass Co.

Cost: \$4,400; furnishings \$950 additional.

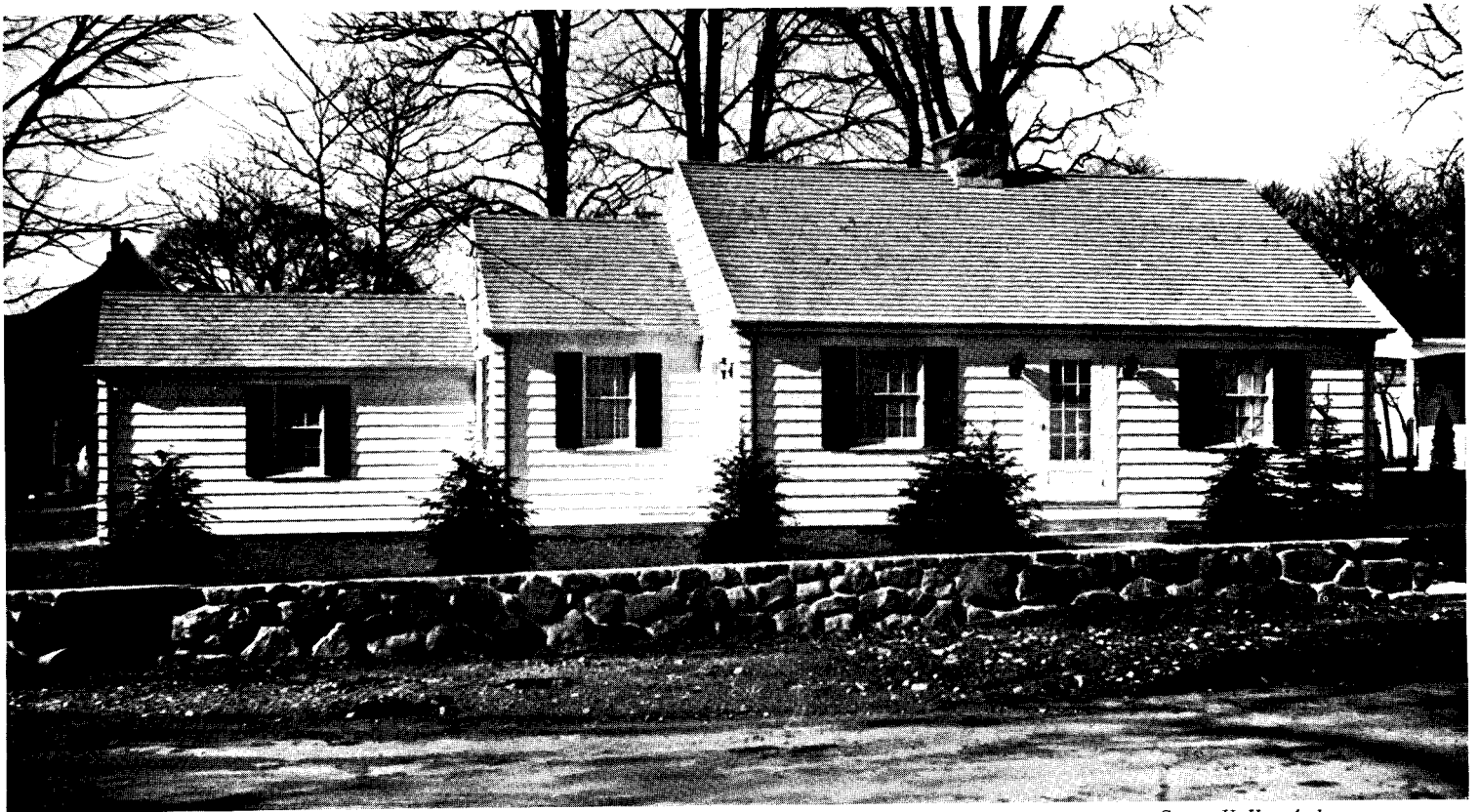

George H. Van Anda

## A FIVE-ROOM HOUSE

DONALD STRICKLAND RESIDENCE  
DARIEN, CONNECTICUT

WALTER BRADNEE KIRBY  
Architect

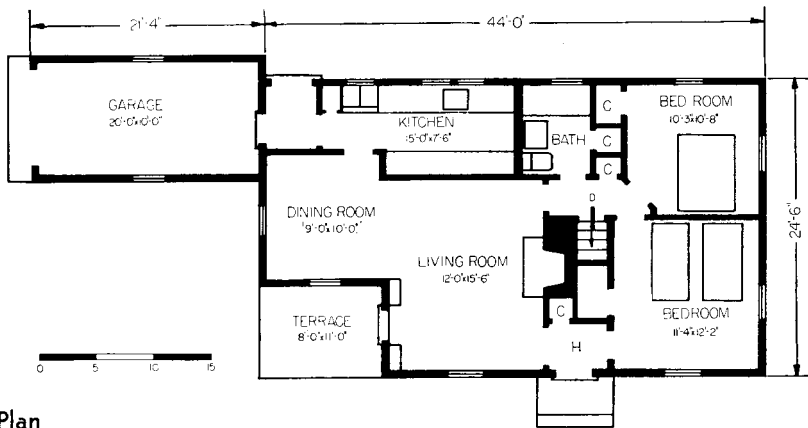

Plan

### SCHEDULE OF EQUIPMENT AND MATERIALS

FOUNDATION	Concrete
STRUCTURE	Wood frame
EXTERIOR	
Walls	Cedar shingles
Roof	Shingle
Sash	Wood double-hung
INTERIOR	
Floors	Oak, except rubber tile in kitchen and bathroom
INSULATION	U. S. Gypsum Co.—flexible blanket-type in ceiling and roofs

### HEATING

Steam, American Radiator Co.; Taco water heater; Petro oil burner

### HARDWARE

Bronze, Yale & Towne

### LIGHTING

Bx wiring; Chase Co. brass fixtures

### PLUMBING

Standard Sanitary Mfg. Co. fixtures

### SCREENS

Bronze wire cloth

### PAINTING

Exterior: white with red shutters  
Interior: ivory

Cost: \$6,500; landscaping \$100 additional.

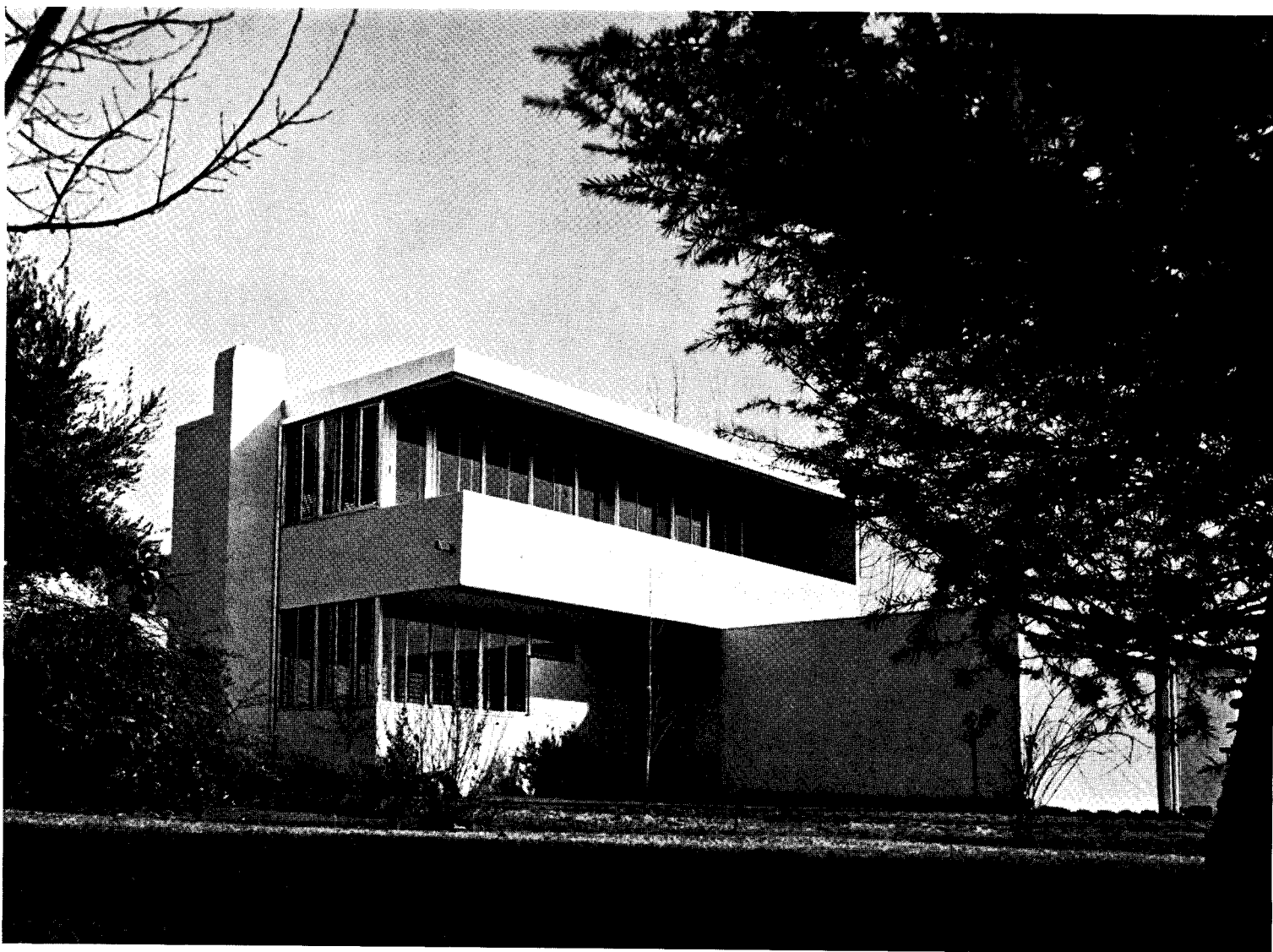

# A SIX-ROOM HOUSE

FRANK DAVIS RESIDENCE  
BAKERSFIELD, CALIFORNIA

RICHARD J. NEUTRA  
Architect, AIA

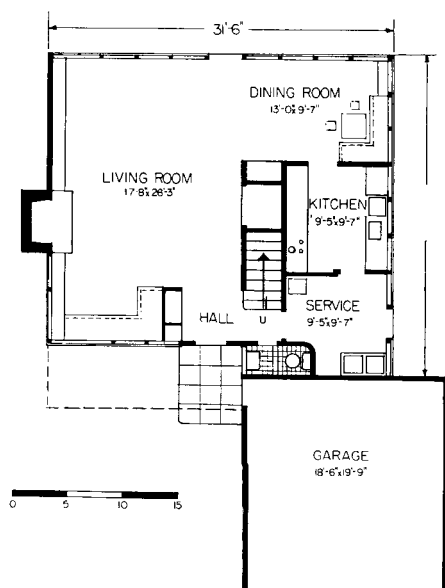

First Floor

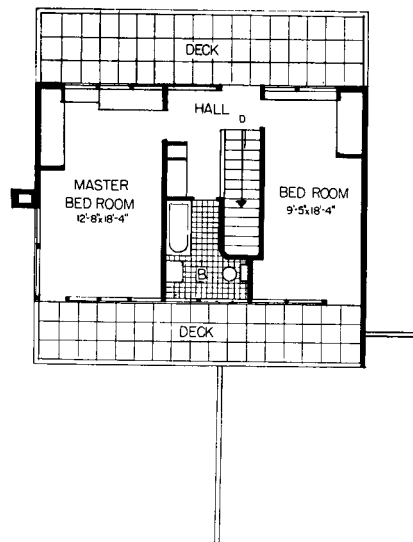

Second Floor



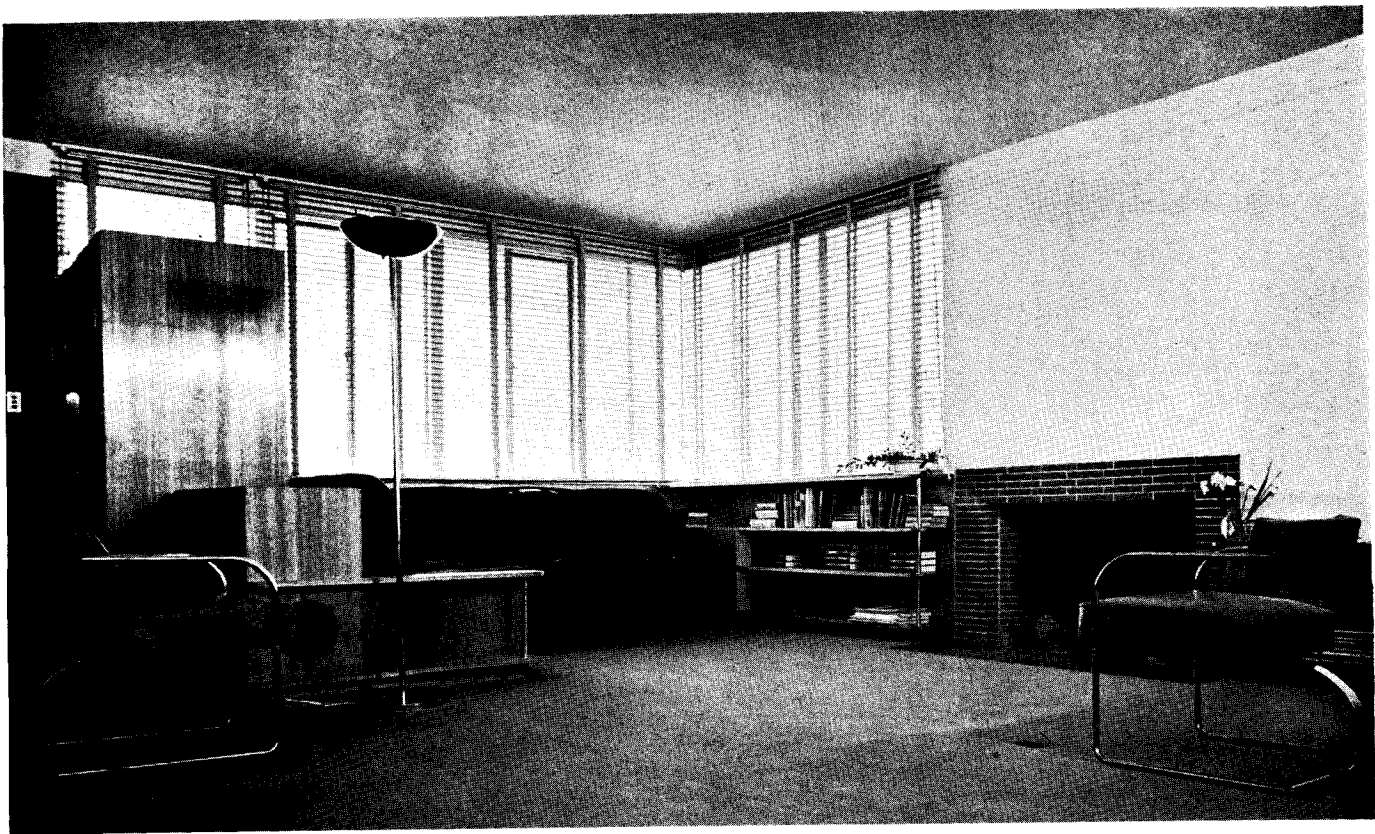

Living room walls are finished in eggshell enamel above the stained mahogany wainscot. One corner of each bedroom accommodates necessary storage areas. In the master bedroom (right) a battery of built-in drawers, of varying sizes, affords maximum accessibility and identification of storage.

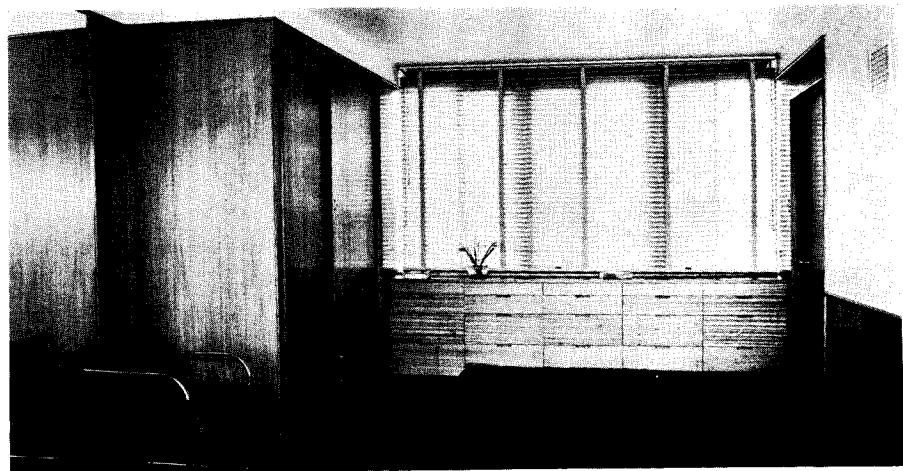

### SCHEDULE OF EQUIPMENT AND MATERIALS

<b>FOUNDATION</b>	Reinforced concrete
<b>STRUCTURE</b>	Wood frame
<b>EXTERIOR</b>	
Walls	Waterproof cement plaster; brushcoat. U. S. Gypsum
Roof	"Pabco", built-up gravel surface
Sash	Insulated steel sash, Druwhit Metal Products Co.; roller screens
Metalwork	Armco
<b>INTERIOR</b>	
Floors	Carpeted; Goodyear linoleum; tile in bath-rooms, Pomona Tile Co.

Walls

U. S. Gypsum plaster; Sanitas; mahogany plywood wainscoting

INSULATION

Celotex in walls and ceilings; rock wool under roof, St. Louis Firebrick Co.

AIR CONDITIONING

Marvellaire forced-draft unit; thermostat control; Johns-Manville, Transite vent pipe

PLUMBING

Kohler Co. fixtures; Youngstown pipe

LIGHTING

Built-in, indirect

HARDWARE

Schlage Lock Co.

GLASS

Pittsburgh Plate Glass Co.

PAINT

Fuller Co. and National Lead

Cost: \$7,500; landscaping \$150 additional.



Gustav Anderson

## A SIX-ROOM HOUSE

CHARLES H. HALSEY RESIDENCE  
HARBOUR GREEN, LONG ISLAND, NEW YORK

RANDOLPH EVANS  
Architect

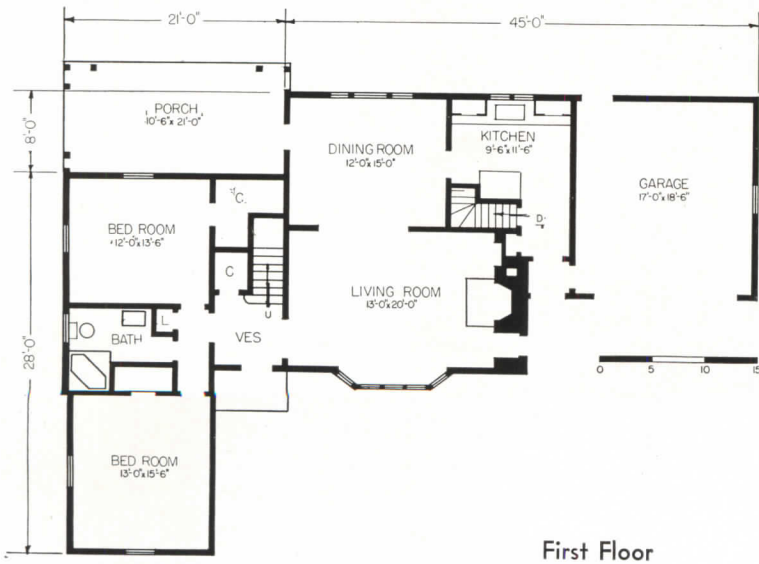
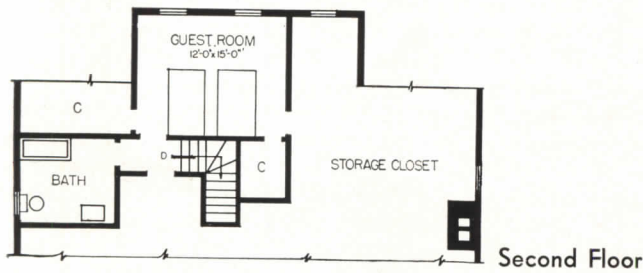

### SCHEDULE OF EQUIPMENT AND MATERIALS

<b>FOUNDATION</b>	Concrete in excavated portion, concrete block elsewhere
<b>STRUCTURE</b>	Wood frame
<b>EXTERIOR</b>	
Walls	Wood shingles
Roof	Cedar shingles
Sash	Wood double-hung; bronze wire screens
<b>INTERIOR</b>	
Floors	Wood, except tile in baths, linoleum in kitchen
<b>INSULATION</b>	Johns-Manville, rock wool in ceiling, rigid board in side walls
<b>WATERPROOFING</b>	Integral
<b>HEATING</b>	Steam, American Radiator Co.
<b>PLUMBING</b>	Standard Sanitary Mfg. Co. fixtures
<b>HARDWARE</b>	Brass, Schlage
<b>LIGHTING</b>	Direct; brass fixtures
<b>PAINTING</b>	Exterior: white walls, green shutters Interior: cream trim and wallpaper
Cost: \$7,500; landscaping \$350 additional.	

# Small House Living Standards

RESULTS of the RECORD's small house questionnaire cannot, by any means, be regarded as a conclusive answer to the question "What kind of house for \$7,500?" Although replies were received from twenty-nine of the thirty-seven Eastern States in which the questionnaire was circulated, its coverage of building designers was too scant to warrant its being regarded as anything more than a fair sampling of competent opinion.

On this basis, however, some interesting conclusions can be drawn. But as outlined in the following pages, these conclusions present a picture in which vast potentialities for technical improvement stand out in bold relief against a background of high building costs, traditional habits of living on the part of the buying or renting public and what seems to be a lack of technical initiative on the part of building designers themselves.

## The "standard" house

This simple picture can be sketched easily from the thousands of answers—some cryptic, many others well-considered and full of valuable information—which the RECORD's questionnaire produced. These revealed that the small house costing \$7,500 implies, to the great majority of designers who answered, a dwelling of Colonial design, averaging in size about 23,000 cu. ft. in Northern and Western areas and about 24,750 cu. ft. in Southern localities. It is commonly two stories in height, although in the South and West one-story houses are frequent; and it almost invariably has a pitched roof in

*(Continued on page 150)*



## ABOVE-THE-AVERAGE SIX-ROOM HOUSE

Judging from questionnaire replies, this house would be considered an above-the-average value in all parts of the country. It is located at Spring Glen, Conn., and was designed by Harvey Paul Conaway, Architect. Facing north, thus giving best exposures to major living areas, it contains 24,650 cu. ft. and cost \$7,250 at 29 1/2c per cu. ft. Construction is veneer and frame over 12-in. concrete basement walls, externally waterproofed and including a recreation room. Walls, partitions and ceilings are insulated with rigid board. Rooms are heated by a hot-water system without air-conditioning facilities; water piping is brass; and bathroom and kitchen plumbing fixtures are of a standardized, high-grade type. Wall brackets light the living room, bath and lavatory; ceiling fixtures are used elsewhere; and all wiring is encased in flexible conduits. House contains no built-in equipment except in dining alcove and well-arranged kitchen.

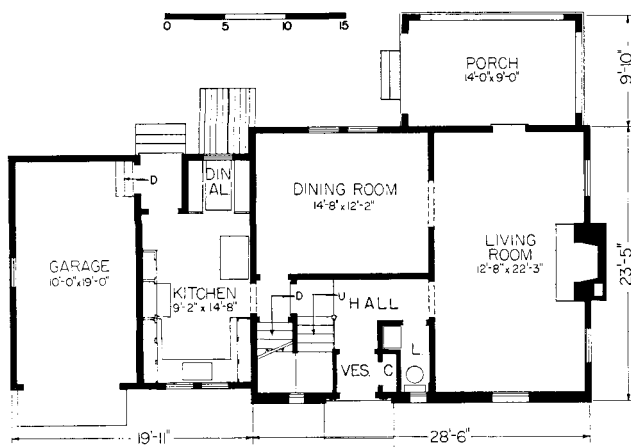

First Floor

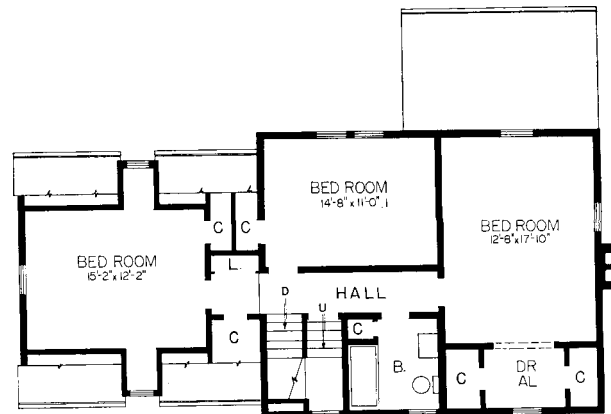

Second Floor

preference to a flat one. Invariably a basement is included.

**Construction** is usually of frame, generally because of lower costs, but also because of preference for this construction in scattered instances. Sometimes walls are partially or entirely veneered with stone or brick, but solid masonry is rarely used except in the few cases where code requirements make fireproof construction mandatory. In the great majority of cases the house is insulated, at least in the second-floor ceiling or roof, and often in walls as well. No well-defined preference for any particular type of thermal insulation was indicated. Insulation of any type for the control of sound was deemed unimportant except by a very few designers.

**Rooms** are fairly standard, so far as the number and type are concerned, although relative location varies, depending largely upon orientation or interior layout. In the basement are, usually, a recreation room—in most cases under the first-floor living room—space for storage, a heater room, usually containing space for fuel storage, and an area in which are generally set two laundry tubs, supplemented, in scattered instances, by a small laundry stove and an ironing board. Washing machines are rarely furnished. Domestic hot-water heaters are usually standard equipment, located near the heating plant.

**The first floor** contains a small hall, living room—almost invariably with a fireplace—dining room, breakfast alcove or “dining nook”, and a kitchen. Small pantries are sometimes included. In addition, most houses have a small lavatory, a coat closet and a small utility closet on the first floor. In two-story houses first-floor bedrooms are rare, but when present are often placed relative to other rooms for use as a “den” or sleeping space as required. A porch is commonly included, opening from the living room, dining room or both. In most cases it is covered and sometimes fitted to receive screens or a glazed enclosure.

**On the second floor** are three bedrooms a bathroom, a small linen closet and usually little more. Bedrooms contain at least one closet, sometimes two; and one closet is frequently larger than the others and sometimes lined with cedar. Extra spaces, such as sewing rooms, are rarely included, although frequently the largest bed-

room has space at one end for use as a dressing room which will become a bathroom at a future time. Two bathrooms are not usual in this “standard” house; and built-in, or fitted wardrobe closets, window seats, cabinets, etc. are usually omitted as being too expensive.

**Equipment** appears to be almost as well standardized as space provisions. Bathrooms, most of them averaging from 35 to 50 sq. ft. in area, contain the usual three fixtures, all first quality, and usually a medicine cabinet set into the wall construction. In some instances a small linen closet is included. The tub is commonly fitted with a shower head; and when a second bathroom is provided, stall shower is likely to replace the tub. Lavatories occupy from 15 to 30 sq. ft. and usually contain minimum-size, inexpensive fixtures. Kitchens are usually assembled in the shape of a compact U, and in most cases appear to follow recommendations of home economics experts in regard to relative location of storage and mechanical units. However, the “standard” house does not ordinarily contain completely standardized or “matched unit” kitchens; and usually mechanical elements are confined to a gas or electric refrigerator, gas or electric stove, and sink. Provision of dishwashers, ventilating fans, waste disposal units or other mechanical housekeeping aids are the exception, according to questionnaire replies.

Heating equipment is a forced hot-air type in the majority of cases, many of which include humidifying devices for partial winter air conditioning. A hot-water system is also often used for heating, but steam heating appears to be exceptional. Coal, oil and gas are all used for fuel, oil being most in evidence in all localities. Automatic, or semi-automatic controls seem to be generally used, although not all questionnaires reported on this point.

In the majority of cases, lighting fixtures are few, but convenience outlets are provided in all rooms. Living rooms often contain no fixtures at all; and when included, a ceiling fixture is usually supplemented only by convenience outlets, rarely by wall brackets. Dining rooms usually contain a central ceiling fixture, as do bathrooms, lavatories and kitchens. In bedrooms wall brackets are preferred to ceiling lights when fixtures are installed at all. Wiring is usually installed in an inexpensive flexible cable. Zoned wiring systems are rarely used in the “standard” house.

The house is usually built on a lot that is approximately 50'x125' in the East and Middle West, about 20% larger in the South and West and varies from about 60'x150' to about 100'x250' in New England. With it is usually built a one-car garage, attached in about 50% of cases. Two-car garages, both attached and separate, are frequently provided.

#### Limitations of Design

So far as factors of construction and equipment are concerned, design standards of the small house costing \$7,500, as outlined in foregoing paragraphs, appear to be largely controlled by a rigid cost limit. On a cubic-foot basis, the average-sized house in the Northern and Western areas (23,000 cu. ft.) would cost approximately 32½¢ per cu. ft.; and in Southern localities the average (24,750 cu. ft.) could be built for approximately 30⅓¢ per cu. ft.

According to the majority of questionnaire answers—including marginal notations which many replies contained—only the spaces and equipment noted can be obtained for these prices. But a large proportion of designers admitted that such standard provisions did not meet all occupancy requirements.

Answers did not make clear, however, what requirements were generally omitted in the interests of economy. To many of the questions dealing with equipment for multiple use of living areas, such as built-in storage spaces, desks, tables, etc. (see page 135) a number wrote the blanketing statement, “Not possible in this cost classification.” Others indicated such provisions as “Not important.” Several others wrote that clients usually listed a series of requirements, provision for which would cost far more than the allowable limits noted.

In general, however, it was not possible to estimate with any accuracy the extent to which occupancy requirements operate as a limitation to design development. Reasons for this lie in the fact that the majority of questions relating to details of these requirements were not answered as fully as those relating to the designer's method of providing for them. Therefore, the deduction can be fairly made that occupancy requirements are not as carefully analyzed by the average building designer as their importance to the design might suggest as necessary.

In view of this, the questionnaire cannot be taken as even a bald outline of provisions for living activities required by the average family. On the

basis of replies, it cannot be reported that the "standard" house fails to satisfy these requirements.

#### The Better House

Because the term is a relative one, it requires a frame of reference. A house can be "good" or "bad" only to the degree that it provides for *all* living requirements of its occupants. A "better house", then, is one which, compared to the "standard" of the RECORD's questionnaire, meets more completely the various needs of those who live in it.

Since living activities within any small house place a premium upon space, a more intensive utilization of floor area appears to be one means of improving design. In a report on the low-cost dwelling made last year by the Construction Industries Committee of the Los Angeles Chamber of Commerce, the following recommendations were made:

"Provide rooms that can be used for more than one purpose.

"Avoid providing more than one room for a single purpose. A dining room should meet all dining requirements, and a breakfast room provided for the same purpose is an extravagance.

"Avoid basement rooms. The cost of building rooms below grade is greater than cost of building on main-floor level.

"Plan rooms to receive furniture they are to contain. A small bedroom with doors and windows properly placed is often more livable than a

larger room improperly planned. Corner windows in bedrooms will often give more usable wall space for placement of furniture."

Regarding space requirements, the following were listed as desirable in a preliminary report on "Basic Principles of Healthful Housing", prepared by the Committee on the Hygiene of Housing of The American Public Health Association:

"A common living room which can be occupied by all members of the family, plus reasonable space elsewhere for withdrawal during periods of entertainment . . . providing 400 cu. ft. of space for each member of the family.

"Where separate rooms are used for living and sleeping, the total for living portions of the dwelling must be 800 cu. ft. per person. When the same room is used for living and sleeping, value should be 500 cu. ft."

Regarding a desirable standard for daylight illumination of living spaces, Dr. James E. Ives, physicist of the U. S. Public Health Service, has stated that window areas should be not less than 17% of the floor area of any room.

Medical authorities have long recognized noise as a source of intense irritation that, if persistent, puts a great strain on the nervous system. The Committee of the American Public Health Association quoted above recommends that noise be excluded from outside the dwelling unit so that ". . . within the unit the noise level shall not exceed 50 decibels;

and a level as low as 30 decibels should be attainable in rooms used for study or sleeping. These standards are based on European practice and call for further examination under American conditions (prevalance of automobiles and radios) and American habits."

The Sub-Committee on Noise of the Housing Commission of the League of Nations recommends that floors should be designed with a noise-insulating value at least 15 decibels superior to that of a bare concrete floor, in relation to control of structure-borne sounds.

Serious effects of noise may develop in a small home where improper provision for manifold living activities results in overcrowding, according to Dr. F. S. Stuart Chapin, of the University of Minnesota. "Normal development of young people is seriously interfered with by loud and constant noise. The condition is intensified when there are too frequent, unavoidable, and hence irritation contacts with other persons in a few small rooms."

Even these few standards point to possibilities for improving living standards in small houses through a more complete provision for the less obvious requirements of family occupancy. They refer largely to comparatively simple procedures in design and suggest that a better house is immediately attainable even within necessary cost limits, through a more searching analysis and a more complete provision for living activities.

## Planning Data for Living Activities

On the following pages are presented results of the RECORD'S questionnaire as they refer to design details of specific parts of the small one-family house. Necessarily some portions of the questionnaire results had to be omitted from this study; but those included refer to spaces which are normally provided to meet the most generally important occupancy requirements. In terms of living activities, these are: 1. General Living Activities; 2. Dining Activities; 3. Culinary Activities; 4. Requirements for Relaxation; 5. Storage Requirements; and 6. Recreational Activities.

In some cases, it was difficult to formulate in a simple and brief report what appeared to be common design practice, even within the same locality. Little attempt has been made to interpret results in the following pages. Wherever possible, dimensions and other design data have been averaged and common practice indicated as a generality, modified by exceptions where these seemed to have an important bearing on the accurate reporting of questionnaire results.

Planning data in the form of diagrams and dimensional

information accompanies each part of the questionnaire report. These were developed independently from questionnaire material as practical graphs to serve as a basis for the design of living areas. They deal largely with allocation of horizontal space indicating, primarily, floor area requirements for various conditions of use.

In all cases, dimensions on diagrams reflect averages only. They indicate area requirements for comfortable use of furniture; and they are subject to adjustment up or down a dimensional scale according to the types and sizes of furniture units involved in any specific instance.

Sources for these data include: for furniture sizes, catalog information of various manufacturers; for clearances, commonly accepted averages for the human figure as developed by Ernest Irving Frees (published in *American Architect*, July, 1934), Maud M. Wilson, Home Economist of the Agricultural Experiment Station, Oregon State College (published in bulletins of that institution and of the Bureau of Home Economics, the U. S. Department of Agriculture, Washington, D. C.), and Bau-Entwurfslehre (Architectural Design) by Prof. Ernst Neufert.

# General Living Activities . . . Sizes, Clearances, Arrangements

SPACE IN the small house for general living activities must often serve a wide variety of functions. Thus, furniture can add greatly to the usefulness of living area if it is adaptable in type and size to a number of different purposes.

Accompanying data give a working basis for providing sufficient space for general living activities. Dimensional information includes only a few of many available sizes and types of furniture. Dimensions of groups refer to clearances necessary for comfortable and convenient use.

Necessary planning considerations include: provision of adequate floor and wall space for furniture groupings; segregation of trafficways from centers of activities; ease of access; and a maximum of flexibility.

Doors in constant use should be placed so that traffic between them will not interfere with furniture groups.

Flexibility implies the varying uses to which space may be put. The lounging group at the right, for instance, requires approximately the same floor space as the card-playing group; the sofa, below, may be a convertible bed. Thus, functions of other areas—such as recreation, sleeping, dining and even storage—may be applicable equally to living rooms.

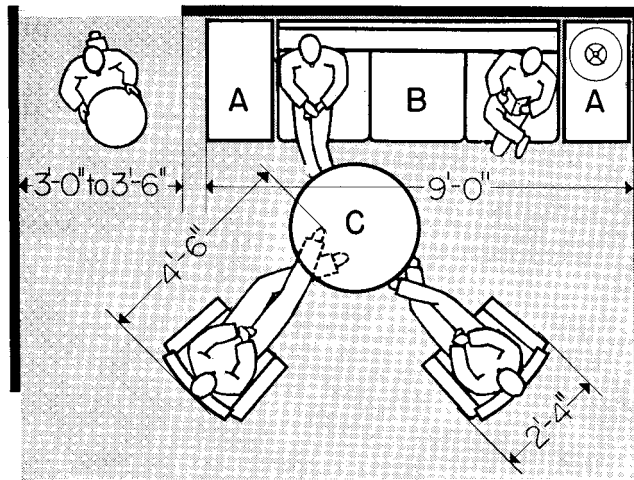

**Sofa Sizes (B):**  
2'-8" to 3'-6" deep  
6'-0" to 7'-2" long  
**Love Seats:**  
2'-0" to 2'-10" deep  
3'-6" to 4'-6" long  
**End Tables (A):**  
10" to 1'-2" wide  
1'-6" to 3'-0" long  
**Occasional Tables (C):**  
2'-0" to 2'-4" square, round, oval, draw-top, etc.

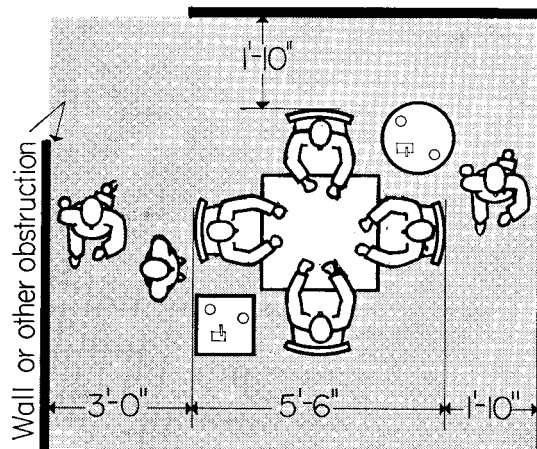

**Card Tables:**  
2'-6" to 3'-0" square; folding type 1/2" thick folded (average)  
**Side Chairs:**  
1'-6" to 2'-0" wide  
1'-6" to 1'-10" deep  
(For folding chairs see "Recreation")

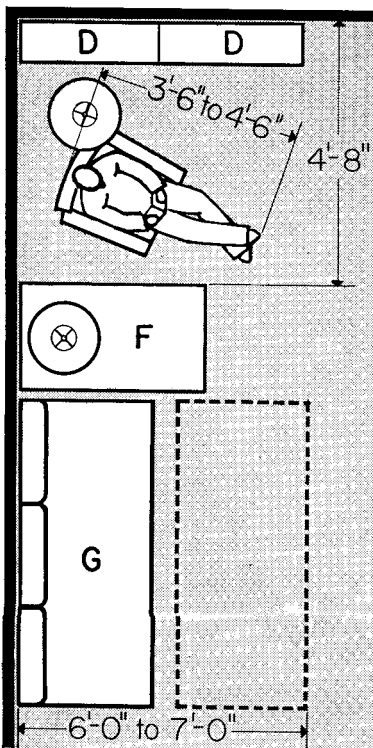

Double Bed Studio Couch

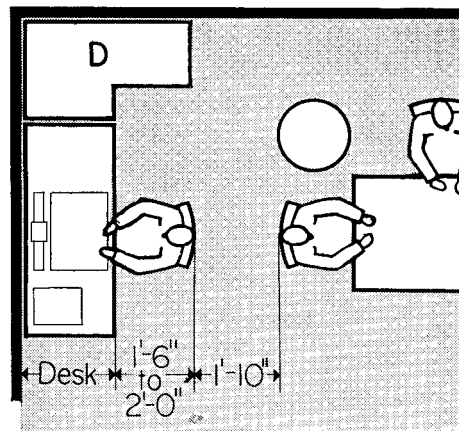

**Desks, Sloping Top:**  
3'-0" to 3'-8" wide  
1'-6" to 2'-0" deep  
**Writing Desks:**  
2'-8" to 3'-6" wide  
1'-6" to 2'-6" deep  
**Secretaries:**  
3'-0" to 5'-0" wide  
1'-6" to 2'-8" deep

**Convertible Sofa-Beds (G):** 2'-9" to 3'-3" deep, 6'-2" to 6'-8" long  
**Living Room Tables (F):** 1'-8" to 3'-0" wide, 3'-6" to 10'-0" long  
**Easy Chairs:** Wing, 2'-4" to 2'-10" square; Club, 2'-4" to 3'-3", 3'-9" square  
**Book Cases (D):** 2'-6" to 3'-0" wide, 10" to 12" deep

Sizes of furniture listed on this page are those most commonly in use. Portable units are available in a wide variety of stock sizes. One type is designed so that pieces may be combined in sets to save space and provide utility comparable to completely fitted, built-in units.

# General Living Activities . . .

## Provisions for conversing, reading, writing, entertaining, dancing, resting, etc. . . .

IN GENERAL the small one-family house contains only a single room for general living. A few of the questionnaires indicated the desirability of another space—a “den” to supplement the “living room”—and a few more stressed the need for additional living areas in a basement room. The great majority, however, specified a first-floor room of the strictly traditional type.

**Size:** A floor area of approximately 270 sq. ft. is common, the content being about 2,250 cu. ft. In most localities dimensions are standard within a narrow range, averaging 13'x 21'x8'-3". In the North, floor areas are somewhat smaller, ceiling heights slightly greater. Dimensions in the South are greater, averaging about 14'x22'-6"x8'-9".

**Preferred Location:** Street frontage is most popular, with side locations next and rear-lot frontage desirable only in rare instances. Orientation for both sunlight and air is an important design factor in all localities. Cross-ventilation is also important; in most living rooms, windows—usually double-hung—occupy more wall space than the commonly accepted 10% of the floor area.

**Accessibility:** Most answers imply necessity for an entrance vestibule or

hall opening into the living room, which in turn has direct access to porch or terrace. Many indicated direct connection between dining and living room desirable. “Open” plans seem general in all localities. Doors are not required to separate major areas.

**Equipment for multiple use:** Built-in units as a desk, window seat, day bed, etc., seem not to be generally required and are rarely furnished. Even bookshelves are “not important” in some cases, although generally furnished. Opinions are scattered and requirements not clear as to storage cabinets for games, bridge tables, etc. Usually they are not included.

**Colors:** General preference is for “light, neutral shades”, mostly tan, buff, cream or ivory. Locality appears to have no more influence on color preference than on the manner in which living rooms are used. Few returns indicated desirability of reds, greens or blues in general living areas.

**Finishes:** Plaster walls and ceilings and hardwood floors are generally standard in all localities.

**Lighting:** Portable fixtures are preferred. In all localities there appear only scattered requirements for ceiling and wall fixtures.



Van Ande

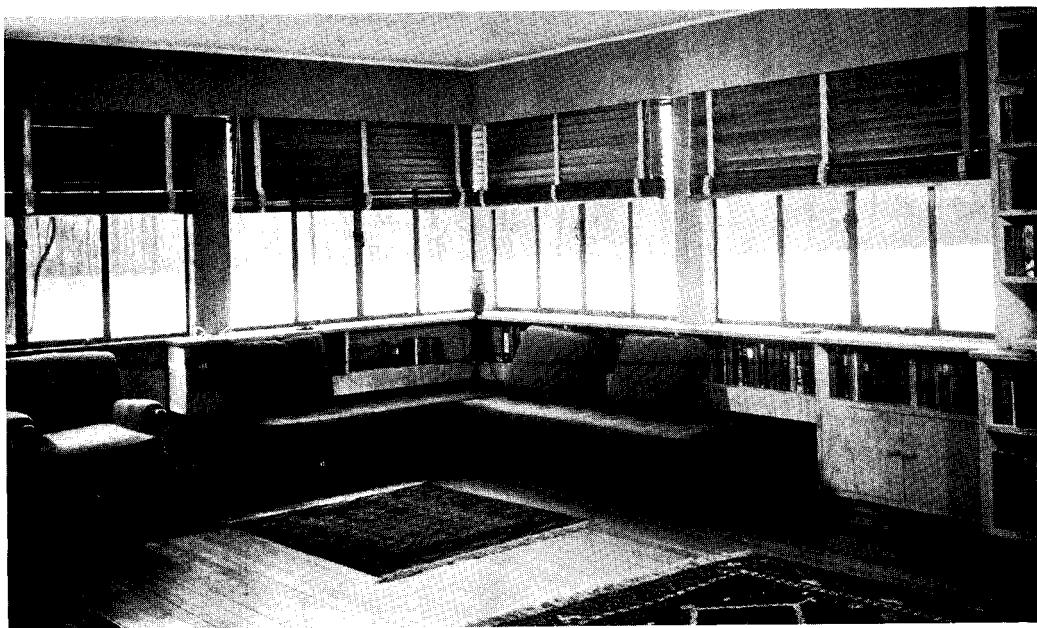

Writing, eating, reading or lounging are activities ordinarily provided for in general living areas. Top: built-in desk, book cases and game storage cabinets; H. P. Staats, Architect. Above: dining area in a living room designed by William W. Wurster, Architect. Left: seats are also studio beds, adding to the general usefulness of a living room designed by Beatty and Strang, Architects.

DINING AREAS must accommodate furniture—either portable or built-in—for eating, sitting, serving and possible storage. Equipment for these dining functions may also be adapted to meet other possible requirements for this space—as studying, game-playing, etc.

Table space requirements per person are as follows: for crowded seating, 1'-10" on the table's perimeter; for comfort, 2'-0". Adequate clearances for use are indicated on diagrams.

### Furniture Sizes:

**Portable Tables, round (A):**  
2'-7" to 5'-10" diam.

**Portable Tables, rectangular (C):**  
2'-6" to 4'-0" by 3'-6" to 8'-0";  
or 2'-0" to 4'-0" square

**Dining Chairs, portable:**  
1'-6" to 2'-0" by 1'-6" to 1'-10"

**Serving Table (B):**  
2'-6" to 3'-6" by 1'-2" to 1'-9"

**Sideboard or Buffet (B):**  
4'-0" to 6'-6" by 1'-5" to 2'-1"

**China Cabinet (B):**  
2'-8" to 3'-8" by 1'-2" to 1'-9"

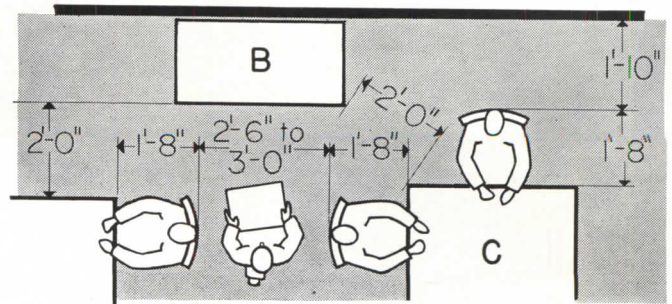
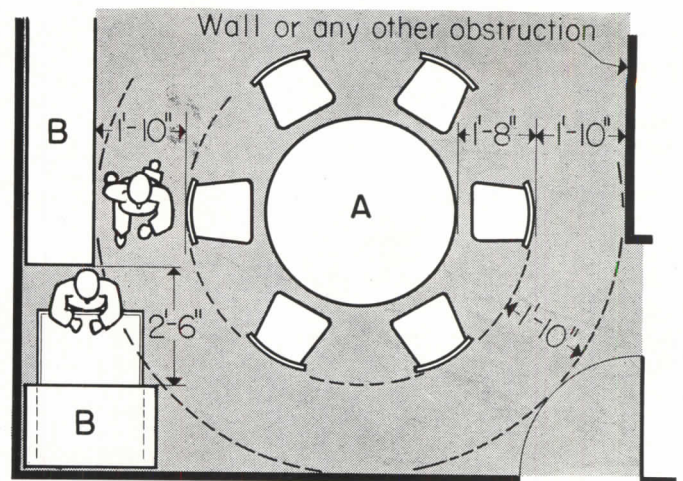
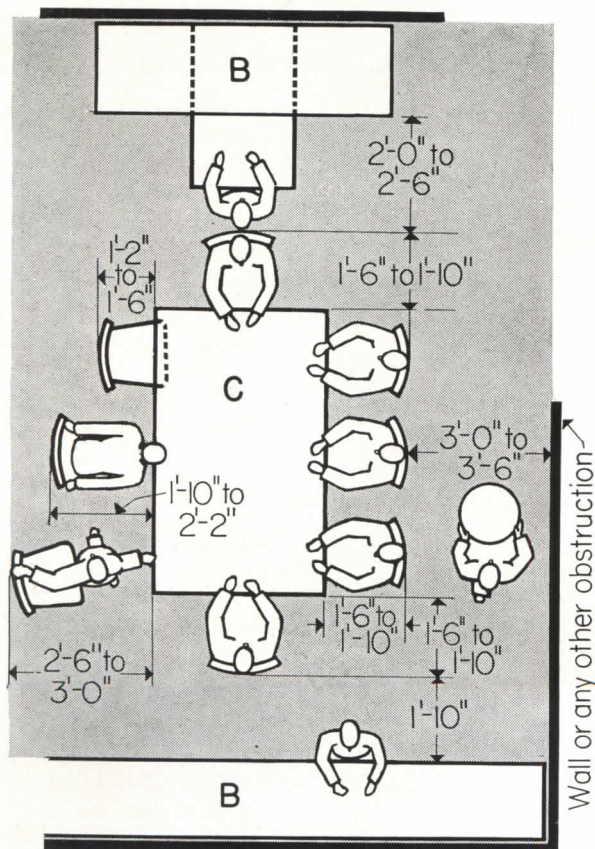
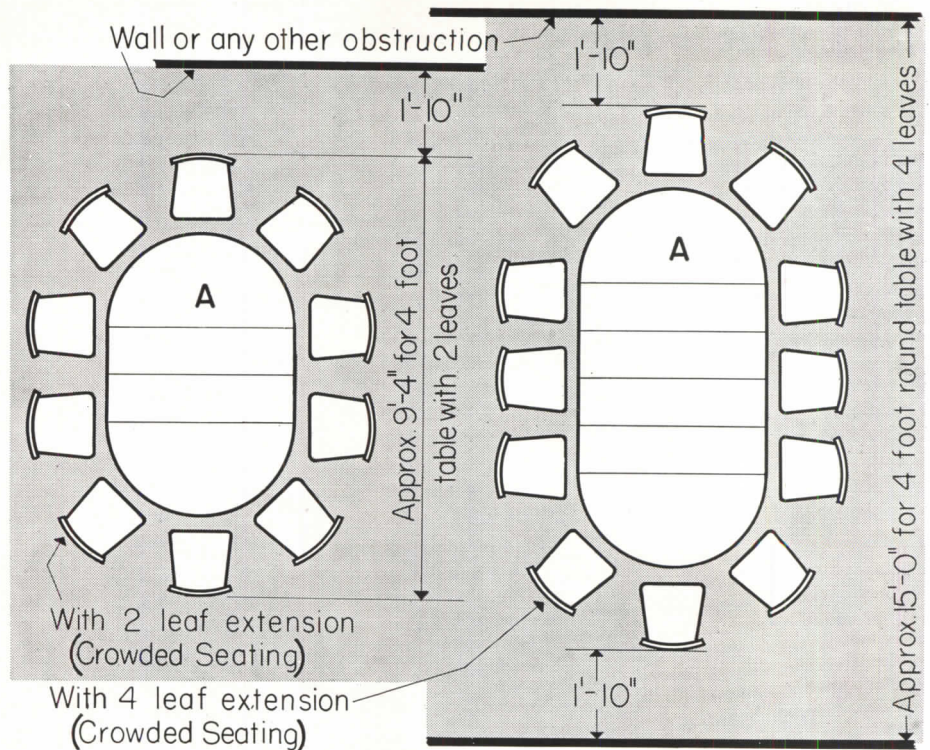



# Dining Activities . . .

## Provisions for eating, drinking, serving, clearing away and storing dishes, group entertaining, etc. . . .

A DINING AREA definitely separated from space for other living activities appears to be a basic requirement of small house occupants. Although a small "nook" near kitchen work centers is generally required for informal eating, a combination of dining and living areas in a single large room is not desirable in the majority of cases. Thus, like the living room, the small house dining room is still largely governed in size, location, appointments and use by traditional habits of living.

**Size:** Most areas are nearly square. The average floor area is approximately 165 sq. ft., measuring 12'x13'-9"; and the average room contains about 1,320 cu. ft. Average sizes in New England and in Middle Western and Western localities are slightly smaller—about 11'-6"x13'—but are larger in the South and East, measuring approximately 12'-6"x14'-9".

**Location:** Reports show that this depends largely upon location of living room, entrance halls and kitchen. About half recommended direct access to both kitchen and living room; the remainder, access from a hall as preferable to an open relation with general living areas. Orientation seems unimportant for this room in comparison with other factors, although large window areas—on two walls if possible—are generally desirable. Comments indicate that, generally, the "separate" dining room is actually set apart from general living areas only by either a hall or by a

partition which is largely opening. In the great majority of cases, however, it is divided from the kitchen by a solid partition and double-swinging door.

**Multiple-use:** This plan relation implies a freely accessible space which can be regarded as part of the living room in the event of group entertaining. Aside from this, however, the dining room is apparently unused during the major portion of the day. And because of its central location and lack of equipment, it seems unsuitable as an area of quiet for reading, writing, studying, game-playing or conversation during the evening. Whether suitable or not, reports indicate that it is rarely used for such activities by the average small house occupant.

**Equipment:** Except for small china cupboards usually placed in corners, no sort of built-in furnishing is ordinarily installed. In the majority of cases this room is lighted from a central ceiling fixture which may be supplemented by portable lamps plugged to convenience outlets.

**Colors and Finishes:** Apparently there exists no well-defined preference—except that floors must usually be of hardwood and colors light in tone. In general, colors and finishes conform with those of the living room when a direct connection exists between the two spaces. Otherwise, the room is often treated to contrast with other areas. Walls are papered.



Gustav Anderson



Richard Averill Smith



Vern Ando

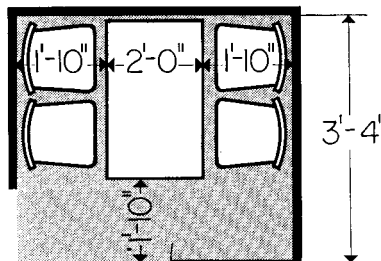
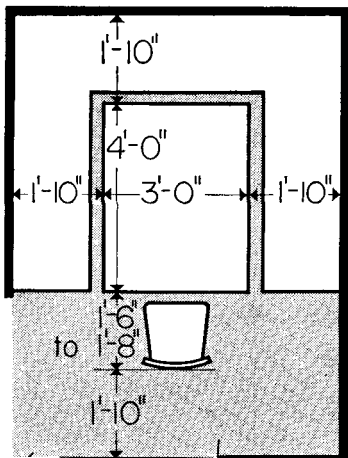

Three types of dining spaces are shown above. Top: a dining room, William Wilde, Architect. Center: outdoor dining terrace, Richard H. Dana, Jr., Architect. Lower: combined dining and living area

in the home of Rockwell Kent, designed and built by the owner. At the left are clearances and typical dimensions for built-in dining furniture, both stock and made-to-order.

STUDIES of time, sequence and space requirements in kitchens, made by various equipment manufacturers, domestic science agencies and others, indicate that kitchen areas can be comparatively small if properly arranged. Three work centers are involved: (1) Storage and Preparation; (2) Preparation and Cleaning; (3) Cooking and Serving. Ideally, tableware storage is included in other rooms.

**Arrangement:** As long as operation sequence (from I to III) is preserved, organization of kitchen equipment may be varied to suit other requirements. Of the accompanying layout diagrams, the U-shaped plan is most efficient in that work centers are most closely related and are entirely separated from general traffic areas.

**Work Center Units and Sizes:** Dimensions given are desirable minima to meet average small house requirements and to provide adequate working clearances.

I—Storage and Preparation Centers include a refrigerator for perishable foods, cabinets for other foods, and counter space. Average linear wall space of 4'-10" to 5'-10" should be allowed.

II—Preparation and Cleaning require a sink, cabinets and the greater part of the counter space. Sinks and special equipment vary greatly in size, but linear wall space of 5'-4" to 6'-6" should be allowed.

III—Cooking and Serving Centers contain the range, counter space and storage cabinets. Average linear wall space required is 5'-0" to 5'-10".

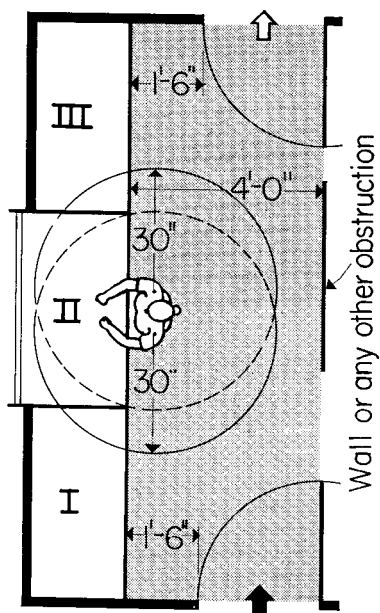

One-wall kitchen

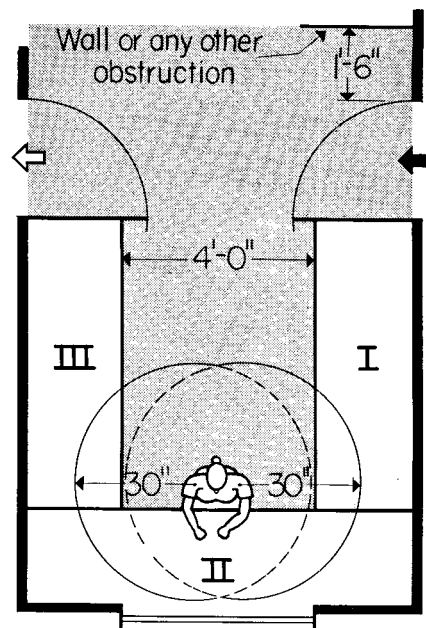

U-shaped kitchen

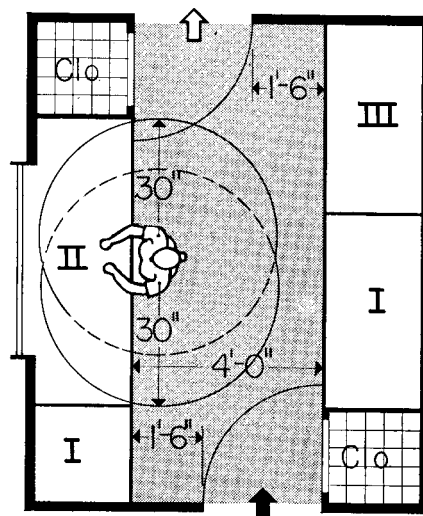

Two-wall or Corridor

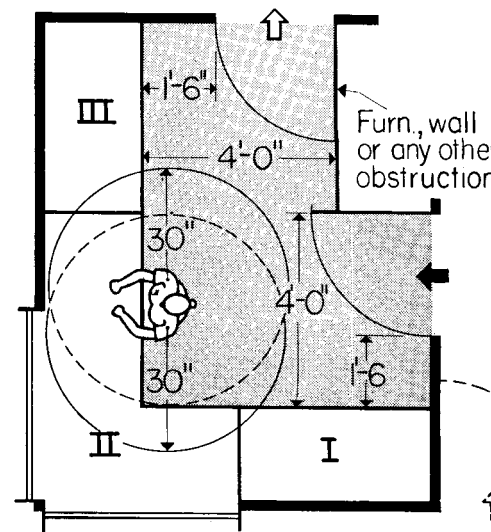

L-shaped kitchen

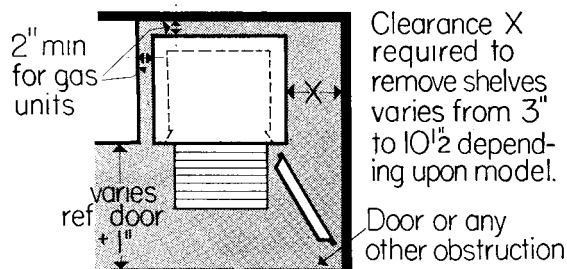

Clearance X required to remove shelves varies from 3" to 10½" depending upon model.

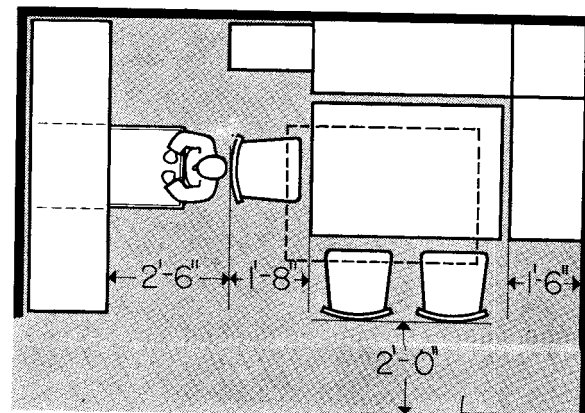
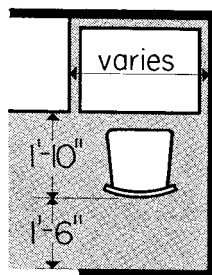

Center: clearances for planning desks. Right: clearances at dining spaces.

Three diagrams showing additional clearances commonly required in kitchens. Left: refrigerator tolerances. Air circulation must be provided; electric types may be built in more closely at sides than gas models if clearance is provided at top, bottom and rear.

# Culinary Activities . . .

## Provisions for the preparation, cooking and serving of food, for storing supplies and utensils, etc. . . .

**KITCHEN AREAS** are by far the most up-to-date of any in the small one-family house as reported in the questionnaire. In general they adhere closely to recommendations of recognized authorities so far as equipment and its arrangement are concerned. In most cases, however, they are larger than authorities recommend.

**Size:** In all localities floor areas averaged approximately 108 sq. ft., giving a content of about 864 cu. ft. Dimensions were close to a standard of 9'x12', as compared with an average of 8'x10', regarded by many authorities as generally adequate. Dimensions were slightly greater in the Middle West.

**Preferred Location:** The kitchen is in the rear of the average small house, sometimes on a corner to obtain cross-ventilation. Some reported a side location as desirable, but a street frontage—logical in view of accessibility and servicing—was rare. Orientation appeared relatively unimportant, though a northerly location was stressed in reports from Eastern and Midwestern localities. Accessibility from entrance hall and direct connection to general living areas seemed not important when the house contained separate dining areas.

**Multiple Use of Space:** Few activities other than those directly concerning food storage, preparation, cooking or serving are now carried on in the average kitchen. Even eating is rarely done in working areas, a separate "nook" or "breakfast alcove" being

provided for this purpose, in addition to normal dining spaces. Few kitchens are equipped with ironing boards, fewer still with laundry tubs. Separate pantries are not common, but a "broom closet" was noted as desirable in about 20% of the reports.

**Equipment:** A comparatively high degree of mechanization is accepted in small house kitchens. Modern types of mechanical refrigerators, gas or electric stoves, "cabinet sinks" and storage cabinets are desirable in the great majority of cases. Ventilating fans, waste disposals, dishwashers and similar units are seldom included, however. No general estimate regarding average capacities or locations of storage cabinets can be drawn from reports. Designers apparently adopt manufacturers' recommendations as completely as possible or adjust specific requirements.

**Arrangement:** In the majority of kitchens, equipment was arranged in a "U" shape, the "L" type being next in preference with scattered specifications for the corridor plan. Almost invariably windows are located over sinks. Lighting usually comes from a central fixture and is supplemented by local lighting at the sink and stove.

**Finishes and Colors:** Easily cleanable materials dominate. These include tile, lacquered wallboard, linoleum and hard painted plaster. Linoleum is preferred for flooring. Hardwoods and rubber tile received scattering mentions. No color preference exists, but light shades predominate.



Gustav Anderson

Above: a kitchen planned by Randolph Evans, Architect. Although some stock units are used, this "corridor" type kitchen is essentially made-to-measure, as is evidenced by the tiled counter, built-in flat-rim sink and dining alcove beyond. Below, left: two examples of "prefabricated" kitchens in which stock units are incorporated. Economies thus effected may permit inclusion of modern conveniences such as mechanical dishwasher, garbage destructors and scientifically correct lighting. Below, right: a diagrammatic section showing working heights for counters and storage cabinets, and indicating necessary clearance between facing cabinets.

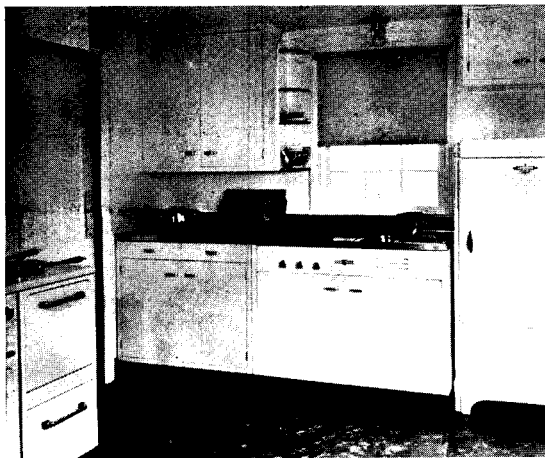

Van Anda

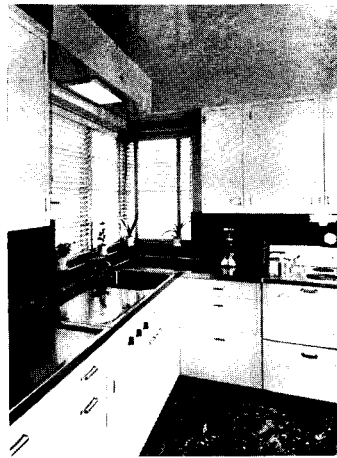

Chicago Arch. Pub. Co.

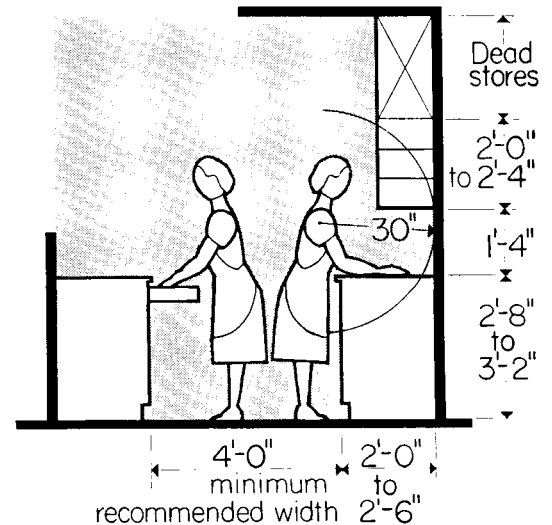

# Relaxation Requirements . . . Sizes, Clearances, Arrangements

DIAGRAMS indicate minimum clearances that should be provided for use of the bedroom furniture shown, dimensions for which are listed below. Many types and sizes of furniture are available; but those listed are most common and can serve as a basis for bedroom design. At least 2" should be allowed as clearance between walls and furniture; 3" between furniture units.

## Beds:

Single (C), metal: 3'-0" to 3'-3" wide; 6'-10" long. Wood: 3'-2" to 3'-6" wide; 6'-10" long.  
Twin (F), metal: 3'-3" wide; 6'-10" long. Wood: 3'-6" to 3'-9" wide; 6'-10" long.  
Three-quarter (E), small, metal: 3'-6" wide; 6'-10" long. Wood: 3'-3" to 4'-0" wide; 6'-10" long.  
Three-quarter (B), large, metal: 4'-0" wide; 6'-10" long. Wood: 4'-2" to 4'-6" wide; 6'-10" long.  
Double, metal: 4'-6" wide; 6'-10" long. Wood: 4'-10" wide; 6'-10" long.  
Roll-away beds, (A): 2'-0" by 5'-0" on edge, 3" clearance on all sides

## Bed Tables (G):

1'-2" to 2'-0" by 1'-0" to 2'-0"

## Bedroom Chairs (H):

Small, 1'-8" by 1'-8"; larger, 2'-6" to 2'-10" by 2'-8" to 3'-2"

## Dressers (3-drawer) (D):

3'-0" to 4'-0" by 1'-6" to 1'-10"

## Chest of Drawers (4-drawer) (D):

2'-8" to 3'-4" by 1'-6" to 1'-10"

## Chaise Lounge:

2'-0" to 2'-4" by 4'-0" to 5'-6"

## Day Bed:

2'-9" to 3'-3" by 6'-2" to 6'-8"

## Dressing Table:

1'-3" to 1'-10" by 3'-0" to 4'-2"

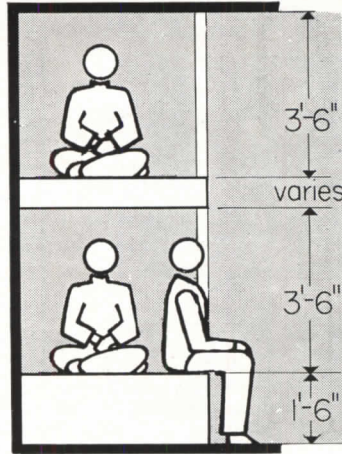

Double-deck bed

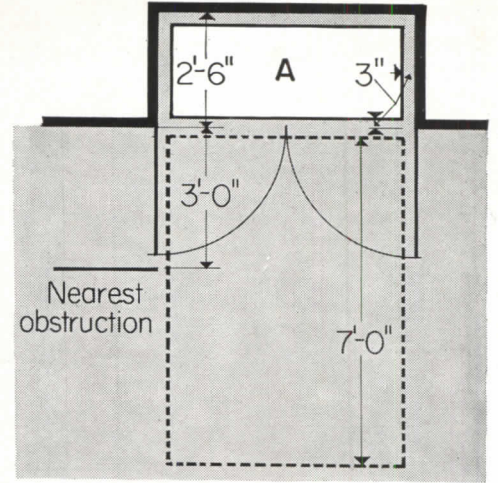

Roll-away bed

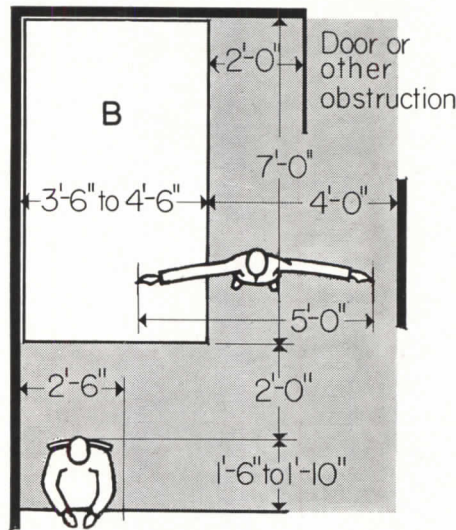

Large three-quarter bed

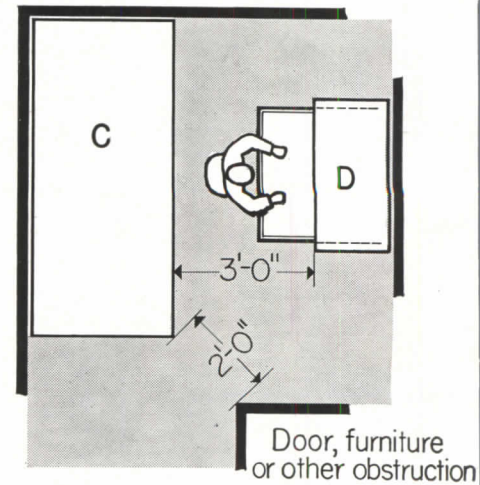

Clearance for dresser

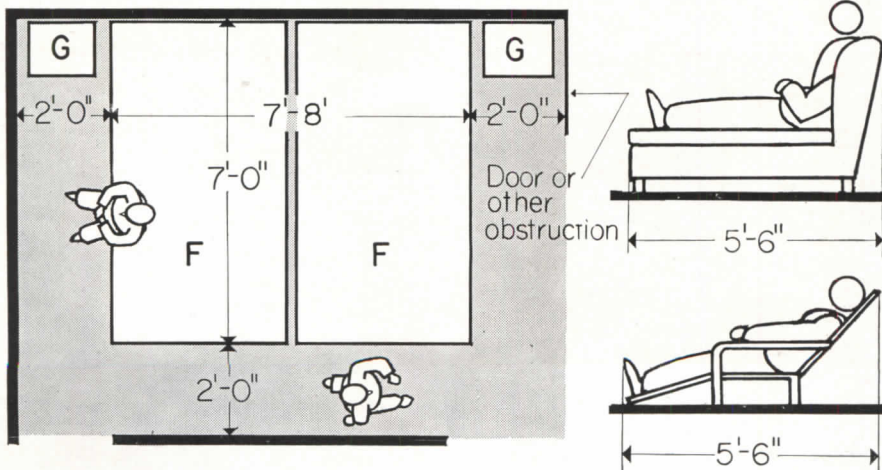

Minimum clearances for twin-bed group

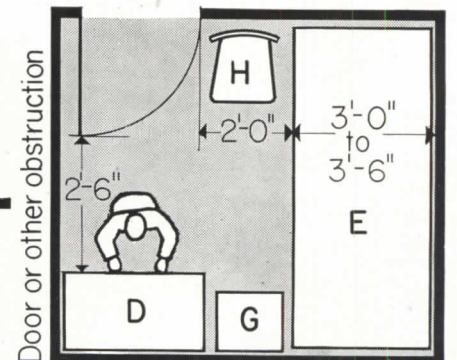

Minimum clearances for single bed and dresser group

# Relaxation Requirements . . .

## Spaces and furnishings for resting, sleeping, dressing, exercising, etc. . . .

THREE BEDROOMS are standard in the small one-family house. In rare cases four are provided, the fourth often being on the first floor and located for use as a maid's or guest room or a "spare room" for any sort of use. With few exceptions the rooms are not designed for anything else than sleeping quarters. They usually contain no built-in equipment except one or two closets—depending on room size—fitted with a shelf and pole.

**Sizes:** Remarkably little standardization of bedroom sizes appears to exist. Floor areas in the South are generally greater than those in Northern localities. Average sizes in most Northern areas are: for one adult, 10'x12', or 120 sq. ft. (sizes ranged from 8'x10' to 12'x14'); for two adults, 11'-3"x16'-6" or 186 sq. ft. (sizes ranged from 10'x11' to 13'x20'). For one child, 8'-9"x11' or 96 sq. ft. (sizes ranged from 7'x10' to 10'x12'); for two children, 10'-9"x12'-6" or 134 sq. ft. (sizes ranged from 9'x10' to 12'x14').

In the South areas averaged: for one adult 146 sq. ft.; for two adults 184 sq. ft.; for one child 128 sq. ft. and for two children 135 sq. ft.

**Preferred Location:** In Northern localities all bedrooms are on the second floor in most cases. In some three-bedroom houses one room is on the first floor; and where four bedrooms are provided three are usually up-

stairs and the fourth down. Preference in the South appears to be equally divided between a first- and second-floor location for sleeping areas. Because the small one-family house ordinarily contains but one bathroom, second-floor bedrooms are usually grouped about a central hall and generally occupy corner locations. Thus cross-ventilation—apparently important—is easily accomplished.

**Equipment for Multiple Use:** Reports show no strong tendency to equip bedrooms with built-in wardrobes, desks, storage cabinets, etc. to make them as comfortable and convenient for such activities as reading, writing, studying, or listening to the radio as they are merely for sleeping and dressing. In a number of instances such equipment was noted as "too expensive" and in others was classed as "not important."

Although thermal insulation is generally used in small houses, very few reports indicated the need for sound-proofing sleeping areas. Likewise, little was noted regarding control of temperature or ventilation in bedrooms. Apparently these are considered either not important or too costly.

**Lighting:** In all localities a ceiling fixture and a number of service outlets are used. Wall fixtures are not generally used. Great reliance is placed on local lighting, usually from portable lamps.

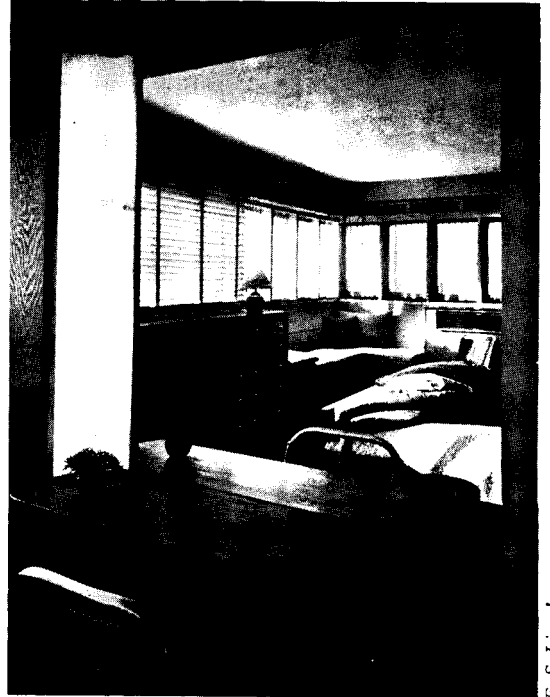

F. S. Lincoln

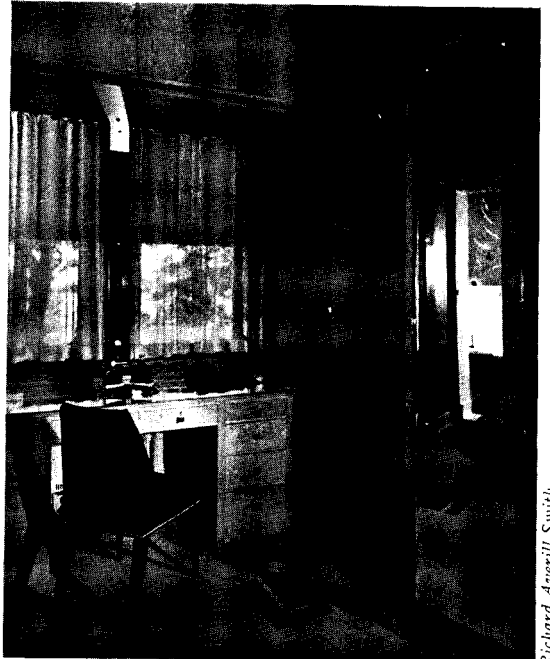

Richard Averill Smith

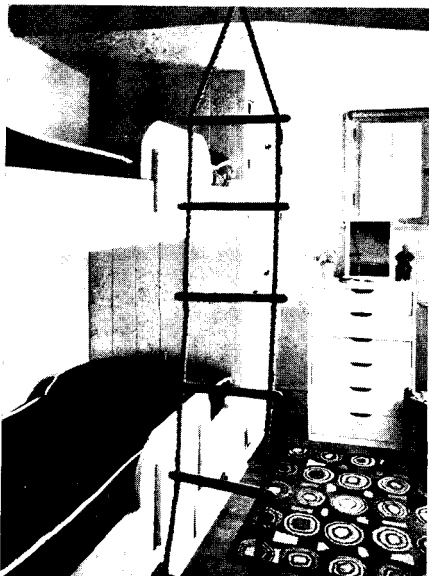

Richard Averill Smith



Richard Averill Smith

General utility of bedroom areas can be increased by use of space-saving, built-in equipment. Top: built-in seat and chest of drawers reflected in mirror of built-in dressing table. Robt. M. Brown, Designer. Above: dressing table alcove combined with storage closets, Pierre Dutell, Designer. Left: drawers combined with bed alcove, Howard Moise, Architect. End: double-deck bunks in child's room, Seymour Williams, Architect.

# Housekeeping Requirements . . . Sizes, Clearances, Arrangements

ACCOMPANYING data give a basis for design of equipment in which to store personal effects, linens, blankets, etc.

Dimensions indicate minimum practical clearances for the storage of articles commonly used, not their actual sizes. Diagrams and dimensions refer primarily to storage requirements of adults and require adjustment for children. Sources of information include actual measurement, studies of storage arrangements made by Maud M. Wilson, Home Economist of the Oregon State Agricultural College (published in 1934 by U. S. Dept. of Agriculture, Bureau of Home Economics), and "Time-Saver Standards."

The extent to which these clearances are maintained, together with accessibility of articles stored, determine convenience and utility of storage spaces. As shown by diagrams on the edge of the opposite page, articles stored on shelves higher than 6'-8" are difficult to reach and should be considered in dead storage. Similarly, 2'-6" is the usual limit of human reach; shelves are in most cases inconvenient if they are deeper than 1'-3". For convenient use, hook strips require at least 6" of clear space—in addition to clearance for garments on hangers. Height of hook strips is normally the same as height of poles.

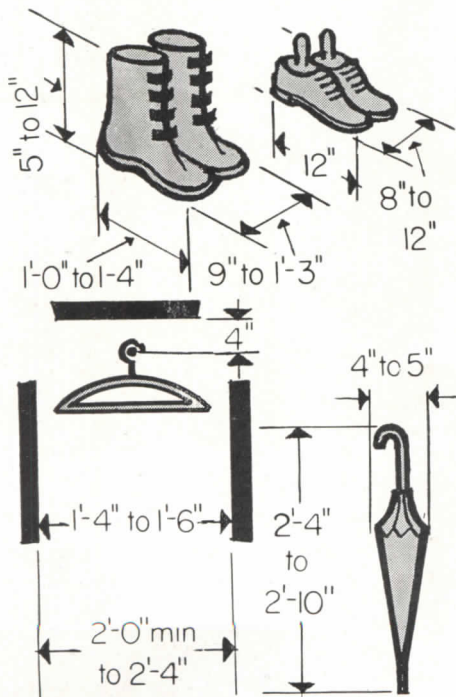

Dimensions for shoes, overshoes, umbrellas and typical clothes hangers

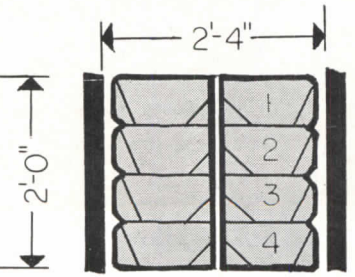
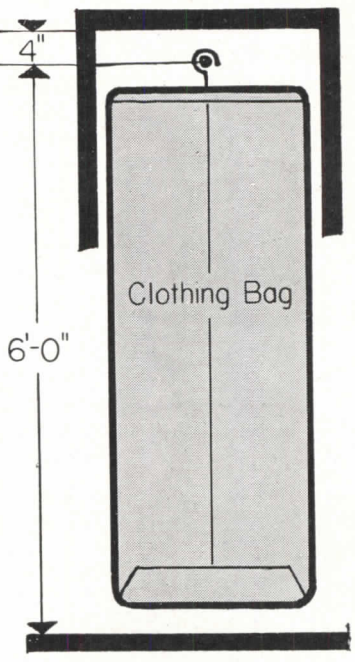
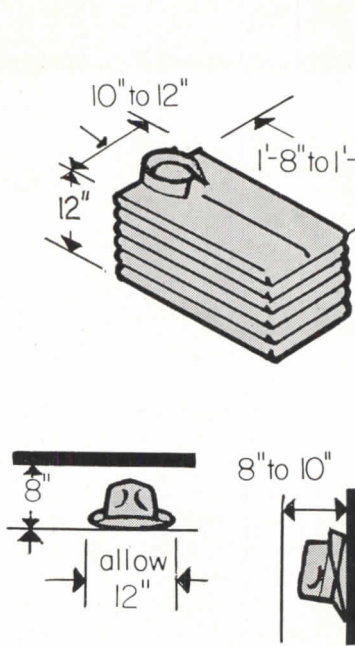

Dead storage. Two feet will hold 4 clothing bags.

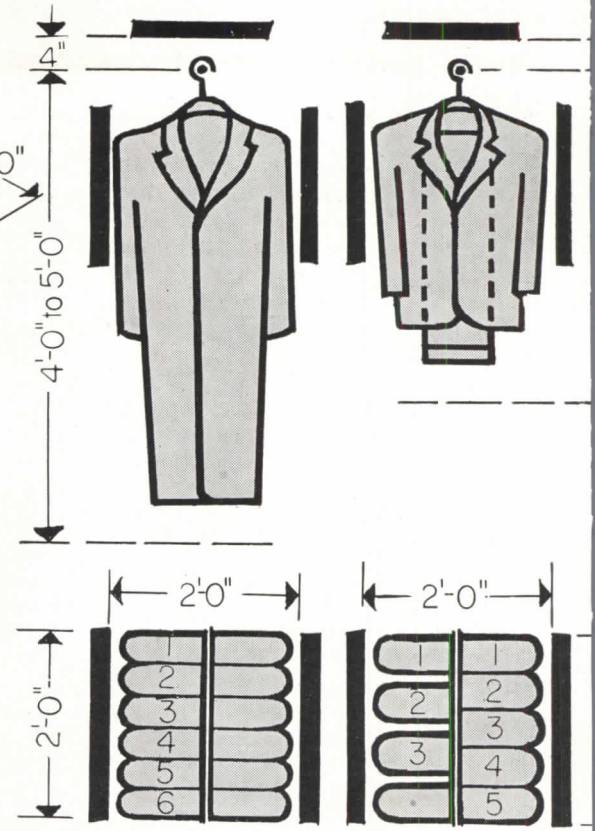

Men's Clothing. A 2-ft. unit will hold 6 to 8 overcoats, 5 to 7 suits, 4 to 6 clothing bags.

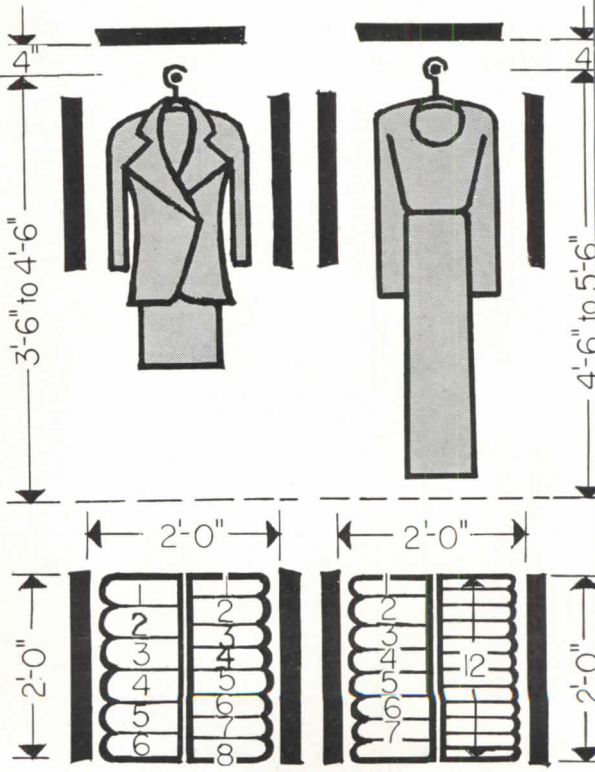

Women's clothing. A 2-ft. unit of storage space will hold 6 to 8 clothing bags, 8 to 10 suits, 8 to 14 dresses.

# Housekeeping Requirements . . .

**For storing personal effects, for heavy storage, for laundering, sewing, cleaning, repairing, etc. . .**

JUDGING from the RECORD'S survey, this important part of the small house is accorded only scant attention by building designers. Statements regarding occupancy requirements were vague in the majority of cases; and provisions for meeting these varied widely in both size and type. The exception refers to bedroom closets. Even these, however, are apparently not developed according to any formula relating specifically to their efficient use.

**Clothing Closets:** A small coat closet on the first floor is usual. The few sizes that were listed ranged from 2'x3' to 4'x9'. In addition a general storage closet on the second floor is generally provided. This—sometimes lined with cedar—ranged from 2'x3' to 3'x5'. Only in rare instances was the need for storage of children's clothing mentioned.

**Bedroom Closets:** Approximate averages for Northern localities are: for one adult, 2'x4', or 8 sq. ft.; for two adults 2'x7' or 14 sq. ft. or, in a number of cases, two 2'x4' closets. Storage for one child averages 2'x3'; for two children 2'x5'. In the South, reports indicated larger averages: for one adult, 2'-6" x 4'-10" or about 11 3/4 sq. ft.; for one child, 2'-6" x 3'-9" or about 9 1/4 sq. ft. Averages, how-

ever, do not indicate the wide variations in sizes, which ranged from 1'-8" x 3' to 3' x 6' for one adult's closet and from 1' x 2'-6" to 3' x 6' for a child's closet.

**Storage for Linens, etc.:** Some space for this purpose is generally provided on the second floor. Reports showed ranges in size from 4 sq. ft. to 75 sq. ft. implying a floor area from 2'x2' to 7'-6" x 10'. Averages could not be deduced from information given.

**Maintenance Materials and Staples:**

In or near the kitchen a small closet averaging 2'x3' in floor area is provided in most cases for cleaning materials and equipment. Some houses have a similar space on the second floor. Staples—as canned fruit, etc.—are stored in the kitchen in a small pantry or in a basement area ranging from 3'x4' to 8'x10' in floor area.

**Laundry and Sewing Space:** Tubs for washing usually are in the basement and are often required. Laundry space requirements varied in reports from 48 sq. ft. to 150 sq. ft. Washing machines and laundry stoves were rarely mentioned. A separate space for sewing is rarely included. When it is, reported sizes range from 16 sq. ft. to 40 sq. ft. of floor area.

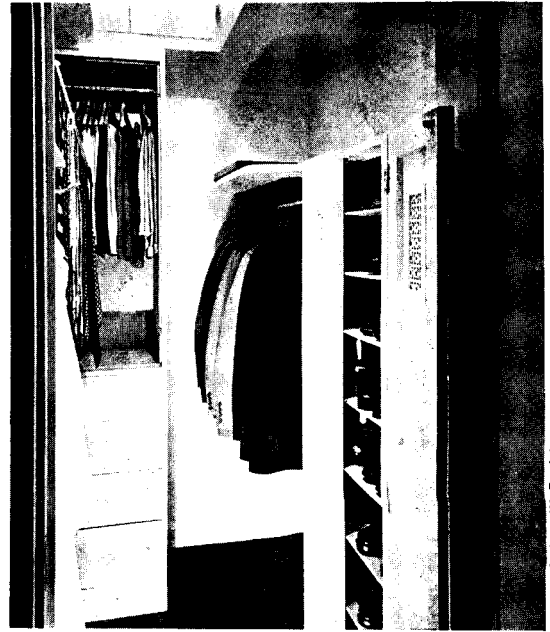

Richard Averill Smith

Built-in shelves, cabinets and racks increase utility of closets. L. Hessler, Designer.

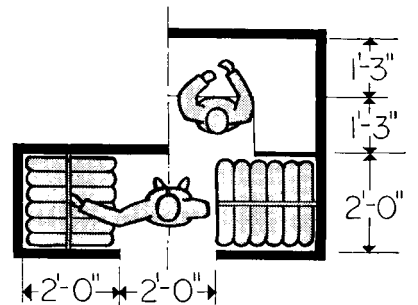
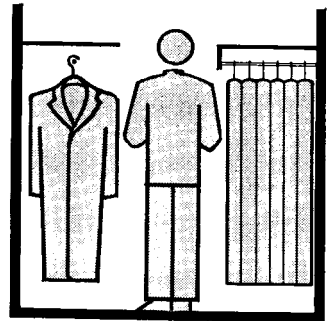
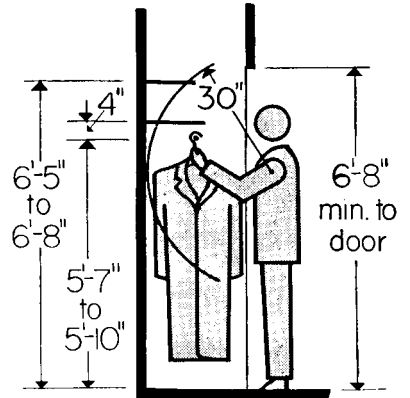

Average space requirements at left:  
 A, 3 pillows; B, 10 to 12 sheets or 24 to 36 pillowcases;  
 C, 12 to 18 small bath towels, 18 to 24 face towels;  
 D, blankets, 3 or 4 heavy, 4 to 6 light;  
 E, bath towels, 8 to 10 large, 16 to 20 medium.

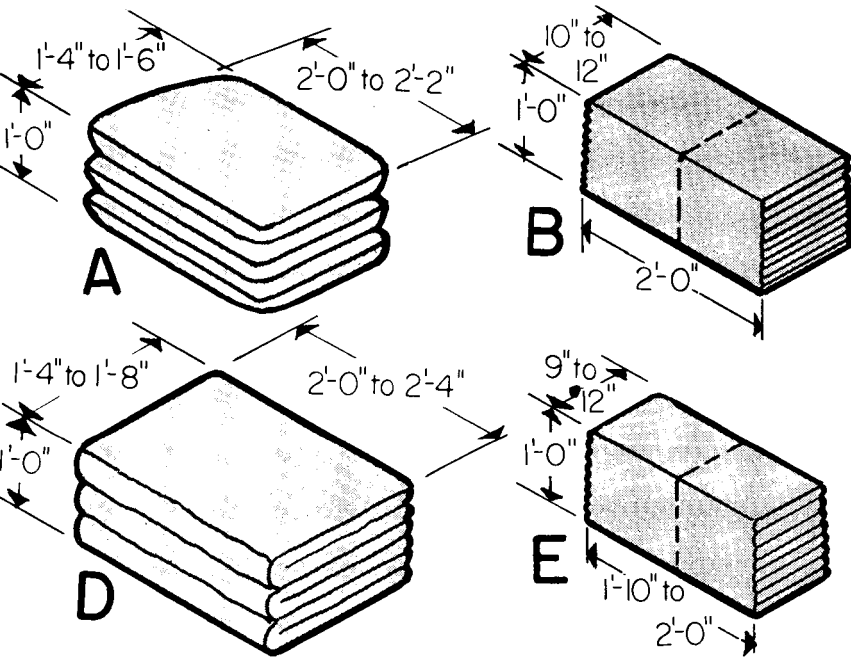

# Recreational Activities . . . Sizes, Clearances, Arrangements

INDOOR RECREATIONAL activities invariably require definite spaces for equipment and clearances for using it. Not all games occupy floor areas indicated as necessary for those diagrammed on this page. But if interiors are planned to accommodate large units of equipment such as that required for table tennis, and provide necessary playing clearances, spaces will be adequate for many other uses as well.

Dimensions of game equipment and floor areas required for its use are both subject to variation. Sizes noted here are comfortable averages, not absolute minima.

Many recreational activities may take place in living or dining rooms. Furniture sizes, clearances and passage widths will be found on pages devoted to living and dining areas, and should be consulted in conjunction with data given here.

Clearance sizes for the average small automobile, bicycles and baby carriages indicated on the opposite page establish a basis for the design of storage areas for this equipment.

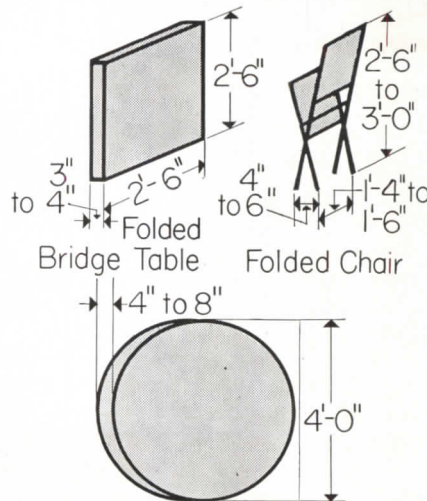

Folded Bridge Table      Folded Chair

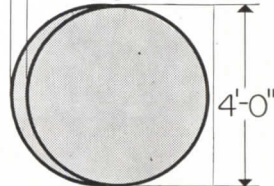

Folded Poker Table

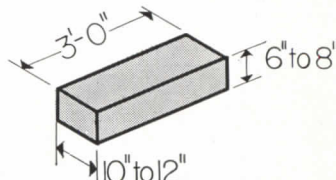

Croquet Set in Box

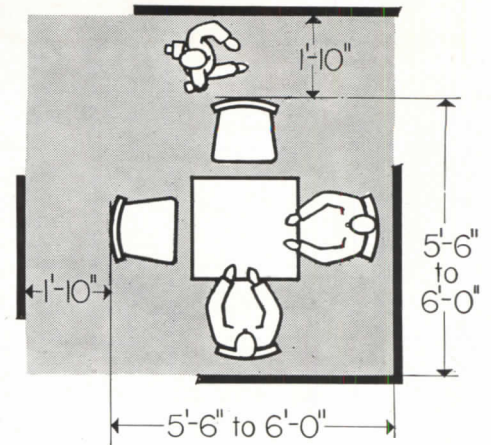

Clearances for playing bridge

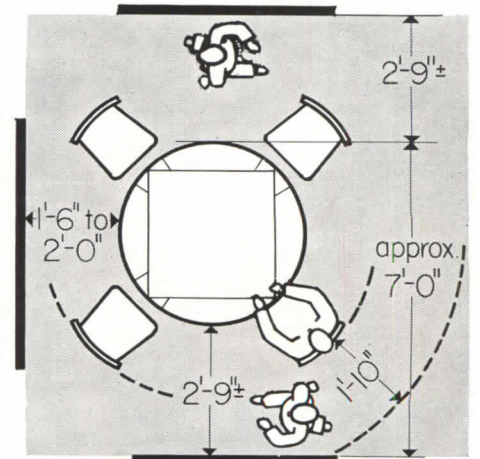

Clearances for playing poker

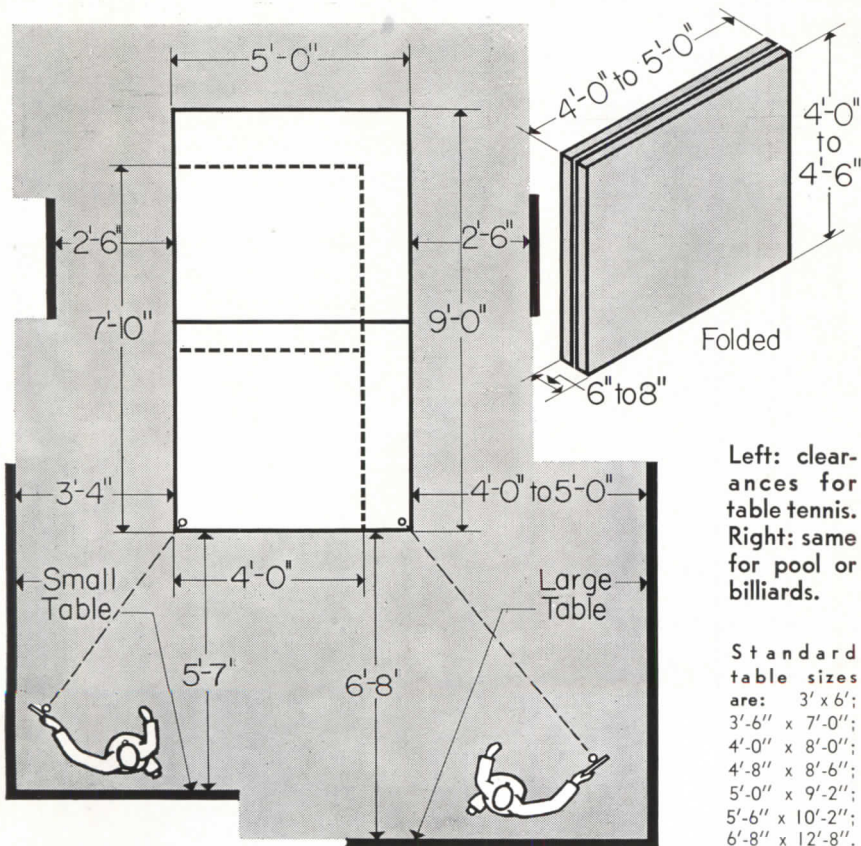

Left: clearances for table tennis. Right: same for pool or billiards.

- Standard table sizes are:
- 3' x 6';
  - 3'-6" x 7'-0";
  - 4'-0" x 8'-0";
  - 4'-8" x 8'-6";
  - 5'-0" x 9'-2";
  - 5'-6" x 10'-2";
  - 6'-8" x 12'-8".

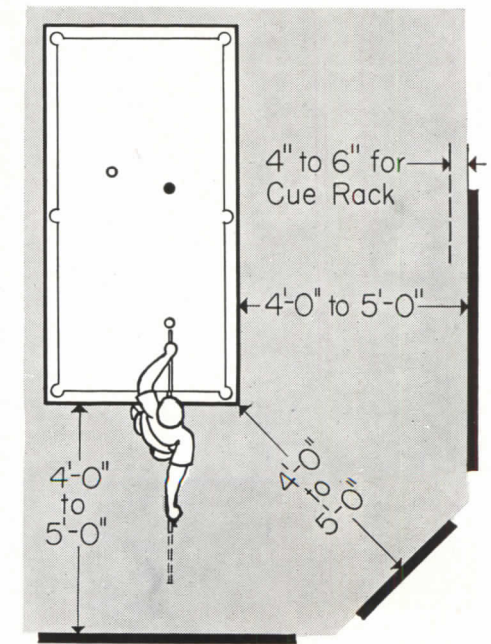



# Recreational Activities . . .

## Provisions for indoor games, parties and hobbies and outdoor activities as gardening, lounging, game-playing, etc.

THE SMALL one-family house has only casual provisions for recreational activities. Basements and attics are used. A porch or terrace is usually provided; and except in rare cases a garage is considered essential. The majority of building designers apparently regard recreational activities as a personal concern of the occupant. Locality seems to have little bearing on the subject.

**Recreation Rooms:** With a few exceptions, space for general recreational activities is provided in a basement room which ranges in size from 12'x14' to 20'x24' and is usually below the living room. The average floor area is 234 sq. ft. and the contents, 1,755 cu. ft. Equipment is usually confined to a ceiling lighting fixture and varying numbers of convenience outlets. Storage space for recreational and sports equipment is "not important" or "too costly" in most instances. The room is waterproofed where required, but rarely treated to minimize effects of noise. Finish is usually paint on walls and floor. Ceilings are generally covered with plaster or wallboard.

**Outdoor Living:** A porch that can be screened or enclosed by glass is more generally desired than an open ter-

race. Porches, located mostly at the rear of the house with access from living room, dining room or both, average 8'-6"x13'-0". They are rarely equipped with storage space for outdoor games or furniture, but contain a ceiling light and a few wall service outlets, also a hose connection.

Other outdoor living activities are almost ignored by designers, judging from the RECORD survey. Scattered mention was made of locating the house to provide for a garden, play space for children and areas for adults' outdoor games. But the comments "too expensive" and "not important in \$7,500 price class" apparently express a general reaction. Some reports, however, indicated a "growing trend" toward outdoor living.

**Transportation Storage:** In a great majority of cases a one-car garage is provided, averaging 11'x20' or 220 sq. ft. in area. When attached to the house—about half reported attached garages desirable—they are usually heated and in general are equipped only with one or more lights and convenience outlets.

A workbench is furnished in some cases; and in others space is included in the garage or a small room added for garden implements, etc.



Van Anda



Gustaf Anderson

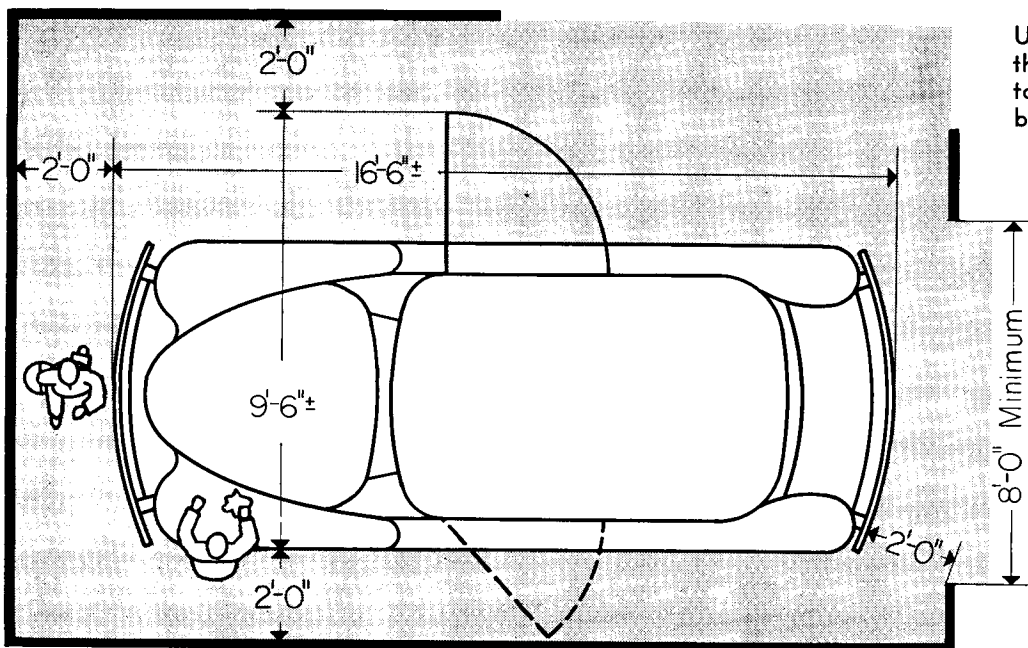

Unusual in the average small house are these two basement recreation rooms, the top one designed by Paul Runge, the other by Walter D. Spelman.

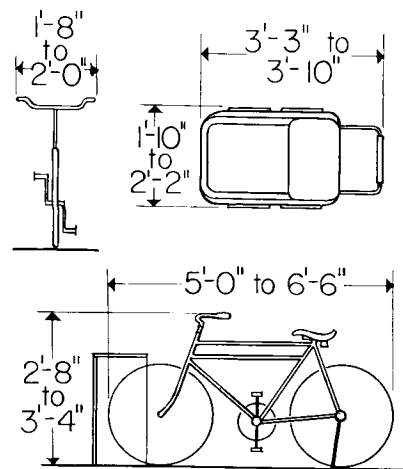

# Conclusions:

THE RECORD'S QUESTIONNAIRE was divided into two parts in order to reveal in a clear fashion: first, what requirements were considered essential, and then desirable, by occupants; and, second, what influences local building customs, variations in labor and material costs, and well-defined preferences had upon the technical means of providing for these requirements.

Many of the returns did not indicate that a clear distinction had been made between these two portions. Although most returns were filled in as completely as the designer was able, the first part, dealing with occupancy requirements, was by far the most sketchy in every instance. In addition, there existed such a duplication of answers in each part of many individual questionnaires, that at least one general conclusion is inescapable.

*It appears that complete, detailed occupancy requirements are not used as a primary basis for designing the \$7,500 house.* From the character of replies no certain statement can be made that *all* requirements are assumed by the designer. But reports provide a basis for saying that, in general, designers appear to investigate occupancy requirements only in a casual way, paying little attention to details of space allocation, construction, and equipment which constitute provision for adequately detailed living activities.

This conclusion was tacitly admitted in several instances. And reasons given in nearly every case concerned cost limitations which made impossible the provision of many details admitted to be desirable.

*Cost is a rigidly controlling factor in the design of a \$7,500 house.* This is a second general conclusion that was clearly defined in every reply studied. Locality has no appreciable influence on this fact; for in localities in which building costs are lower, client demands are proportionately greater.

A third general conclusion, gleaned from direct answers to questions and also from marginal notations, that a large number of questionnaires contained, concerns the design of the "typical small house." With remark-

ably few exceptions these revealed *little effort on the part of designers to make any out-of-the-ordinary provision in planning, construction or equipment to offset limitations of cost or necessarily restricted space.*

Reasons for this were not apparent from reports, except in isolated instances where a marginal comment revealed clearly the convictions of the designer. In part the adherence to a traditional type of six-room Colonial house may be a result of widely similar financing policies which regard such a design as the most generally marketable. If this is the case, however, no proof of it was clearly evident in the collective reply to the RECORD's questionnaire.

These three general conclusions have a direct bearing upon the entire question of housing. Also, they are closely related to one another. Action toward the closer integration of the design problems implied by each could not fail to produce tangible results: improvement in small house design and a consequent increase in the productive activity of building designers themselves.

# Comments:

## From an architect in Maine:

"The average client who has \$7,500 to spend usually has space requirements which will cost him \$10,000. He has requirements regarding materials, equipment, finish and all sorts of gadgets that would bring the cost of the house up to \$15,000. . . . Since he is usually going to do this thing once in his life, he wants the very best that can possibly be produced. On the other hand, he rarely has any ideas as to orientation, circulation or planning in general. Very occasionally he has all these things as well as a sensible approach to the cost problem. But, unfortunately, I am unable to strike an average as to these requirements. The clients' ideas have usually been gained from the advertising which he has read.

"If one is to give a client anywhere near his requirements in a \$7,500 house, I believe the only answer to the problem is to build as simply as possible. It is not practicable to try out innovations in materials or equipment, nor is it possible to work in many of the gadgets that are desirable."

## From a New Haven, Conn., architect:

"The greatest problem before an architect today is to produce a complete home meeting every modern requirement of present living standards for the client of moderate means.

"Higher building costs make it increasingly difficult to fulfill the requirements of clients. (Reduction in the size of houses was necessary to maintain an approximate \$7,500 appropriation in January, 1938 as compared with January, 1937. This was due, primarily, to increased cost of materials.) In many cases they are unwilling to accept the drastic space reductions necessary to overcome the high cost of mechanical conveniences that they deem essential today. However, newer types of construction have resulted in more house, proportionately, for the money involved."

## From a builder in Clifton, N. Y.:

"Several items are necessary and essential, but cannot be put in a house of \$7,500 value and allow a builder \$700 or \$800 on his project, including overhead.

"The average buyer and home seeker, in general, is fairly well satisfied with the average specifications of the \$7,500 home, with one or two exceptions, namely: many buyers want four bedrooms and double garages, an upstairs porch and a lot 50' x 125'. But few of these can afford to pay more than \$7,500 for their house, *including the lot.*"

## From a designer and builder in Atlanta, Ga.:

"In the \$7,500 house, you must consider the fact that one can get approximately one-third more house in this area than in Northern localities. I have had building experience in both sections.

"Atlanta is an open shop area; there are no unions. The prevailing carpenter scale is 50c per hour and will fluctuate from 35c to 75c depending upon a man's ability, experience, etc. Bricklayers make 50c per hour and will lay 1,000 common bricks for \$8. Common labor is paid at the rate of 25c per hour.

"Materials are correspondingly low. Framing sells for about \$20 per thousand. Millwork is in line with Northern prices and so is cement."